

MS3419 and AS85049/26 Crimp Ring Backshell



Crimp Ring
and Banding
Backshells

Glenair Connector Designator A

MIL-DTL-5015 Series 3400,
MIL-DTL-26482 Series 2,
AS81703 Series 3,
MIL-DTL-83723 Series I & III

M85049/26-1-12 W

Basic Part No. _____
M85049/26-1 = Adapter Only
M85049/26-2 = Crimp Ring Only
M85049/26-3 = Adapter with Crimp Ring

Shell Size _____

Finish (Not Applicable
for M85049/26-2)
N = Electroless Nickel
W = 1,000 Hour Cadmium
Olive Drab Over
Electroless Nickel

Shell Size	A Thread Class 2B	C Dia Max
3	.562 - 24 UNEF	.67 (17.0)
8	.500 - 20 UNF	.62 (15.7)
10	.625 - 24 UNEF	.73 (18.5)
12	.750 - 20 UNEF	.86 (21.8)
14	.875 - 20 UNEF	.98 (24.9)
16	1.000 - 20 UNEF	1.11 (28.2)
18	1.062 - 18 UNEF	1.22 (31.0)
20	1.188 - 18 UNEF	1.35 (34.3)
22	1.313 - 18 UNEF	1.47 (37.3)
24	1.438 - 18 UNEF	1.59 (40.4)
28	1.750 - 18 UNS	1.97 (50.0)
32	2.000 - 18 UNS	2.22 (56.4)
36	2.250 - 16 UN	2.47 (62.7)
40	2.500 - 16 UN	2.72 (69.1)
44	2.750 - 16 UN	2.97 (75.4)
48	3.000 - 16 UN	3.22 (81.8)
61	1.500 - 18 UNEF	1.65 (41.9)

MS3419-21 C Superceded Part Number

Basic Part No. _____
Adapter Only

Dash No. _____

Finish
A = Electroless Nickel
C = 500 Hour Cadmium Olive Drab
Over Electroless Nickel

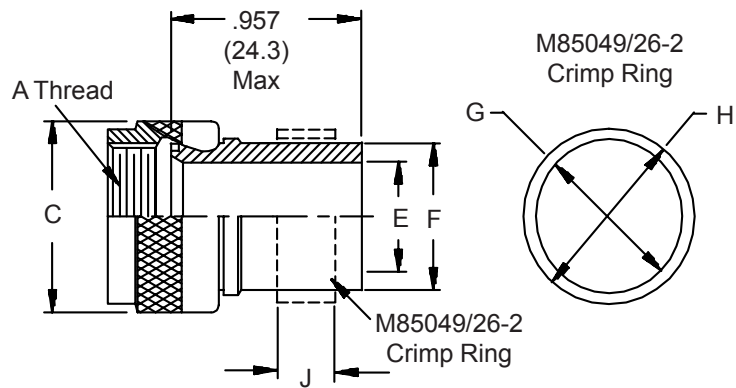

M85049/26-3 (Adapter with Crimp Ring) Shell Size	M85049/26-1 (Adapter Only) MS3419 (Adapter Only)				M85049/26-2 (Crimp Ring Only)				
	Shell Size	E Dia	F Dia		Shell Size	G Min	H Min	J	
3	3	.250 (6.4)	.337 (8.6)						
8	8	.250 (6.4)	.337 (8.6)		8	.400 (10.2)	.448 (11.4)	.250 (6.4)	
10	10	.325 (8.3)	.488 (12.4)		10	.585 (14.9)	.660 (16.8)	.440 (11.2)	
12	12	.420 (10.7)	.500 (12.7)		12	.585 (14.9)	.660 (16.8)	.440 (11.2)	
14	14	.540 (13.7)	.620 (15.7)		14	.705 (17.9)	.780 (19.8)	.440 (11.2)	
16	16	.670 (17.0)	.750 (19.1)		16	.835 (21.2)	.910 (23.1)	.440 (11.2)	
18	18	.789 (20.0)	.880 (22.4)		18	1.005 (25.5)	1.080 (27.4)	.440 (11.2)	
20	20	.914 (23.2)	1.000 (25.4)		20	1.125 (28.6)	1.200 (30.5)	.440 (11.2)	
22	22	1.039 (26.4)	1.120 (28.4)		22	1.245 (31.6)	1.320 (33.5)	.440 (11.2)	
24	24	1.112 (28.2)	1.192 (30.3)		24	1.327 (33.7)	1.402 (35.6)	.440 (11.2)	
28	28	1.389 (35.3)	1.545 (39.2)		28	1.665 (42.3)	1.740 (44.2)	.440 (11.2)	
32	32	1.635 (41.5)	1.795 (45.6)		32	1.915 (48.6)	1.990 (50.5)	.440 (11.2)	
36	36	1.850 (47.0)	2.045 (51.9)		36	2.165 (55.0)	2.240 (56.9)	.440 (11.2)	
40	40	2.065 (52.5)	2.295 (58.3)		40	2.415 (61.3)	2.490 (63.2)	.440 (11.2)	
44	44	2.320 (58.9)	2.545 (64.6)		44	2.665 (67.7)	2.740 (69.6)	.440 (11.2)	
48	48	2.570 (65.3)	2.795 (71.0)		48	2.915 (74.0)	2.990 (75.9)	.440 (11.2)	
61	61	1.210 (30.7)	1.359 (34.5)		61	1.435 (36.4)	1.510 (38.4)	.440 (11.2)	

- For complete dimensions see applicable Military Specification.
- Metric dimensions (mm) are indicated in parentheses.