

Amphenol® EMI Filter/Transient Protection Connectors

12-120-12

*High Technology
Connector Products That
Protect Sensitive Circuits*

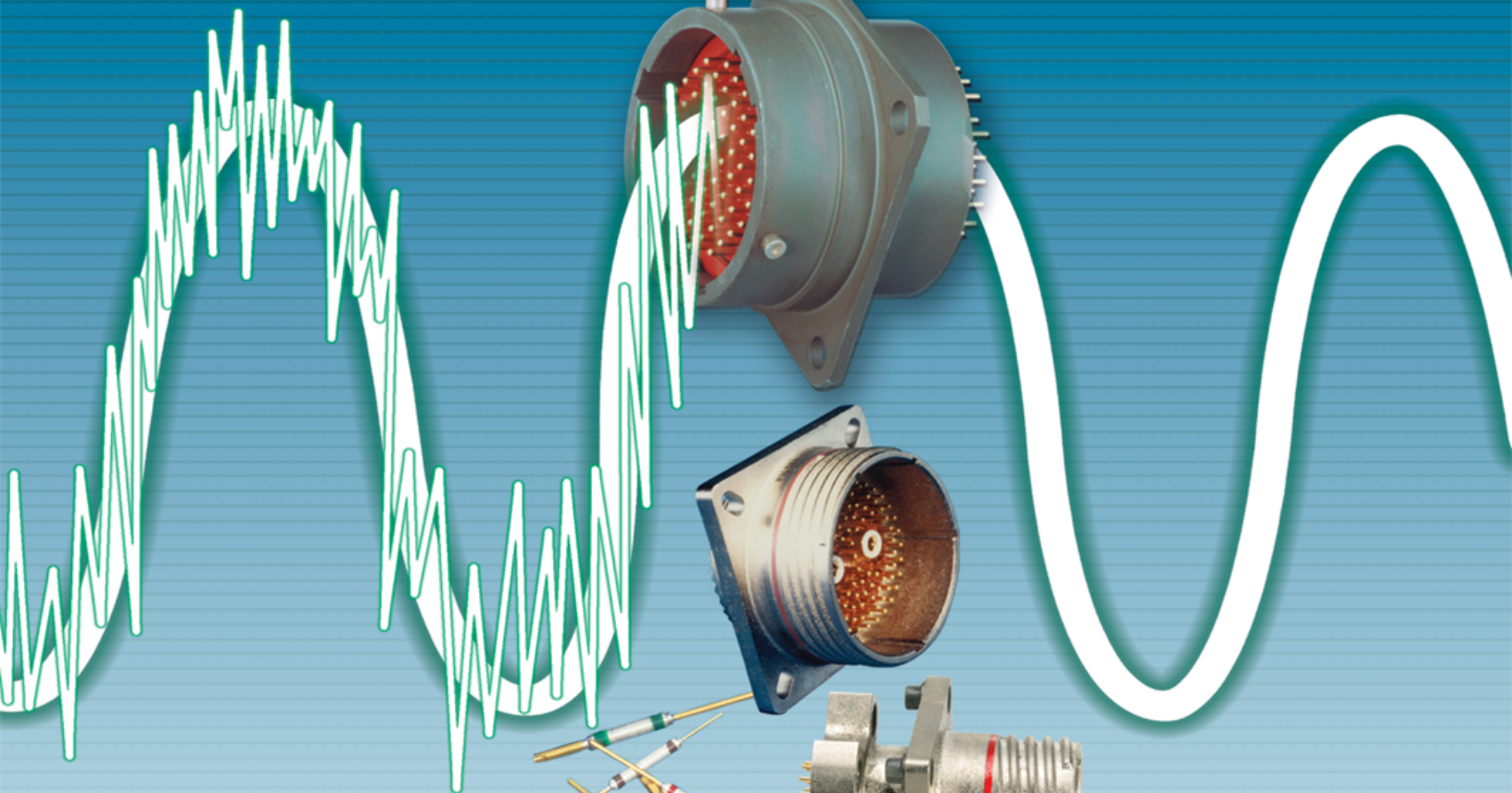

- *Protection in VHF, UHF, HF and other filter ranges*
- *Tubular Contact Assemblies*
- *Planar Array Assemblies*
- *Diodes, MOV'S, Adapters*
- *Filter Composite Connectors*
- *Header Assemblies*

Amphenol

Table of Contents

Description	Page	Description	Page
Amphenol® EMI/EMP Filter Protection Connectors for Protection of Sensitive Circuits	1	FSJT Series (Proprietary SJT intermateable)	
EMI Capabilities	2, 3	Design Features, Alternate Positions	38
Filter Connector Options	4	Wall Mounting Receptacle	39
Filter Selection Data	5	Wall Mounting Receptacle (UTS crimp).....	40
Effect of Temperature on EMI Filter Attenuation	6	Box Mounting Receptacle.....	41
Impedance Matching Formula.....	7	Box Mounting Receptacle (UTS crimp)	42
Quality Assurance Testing	8	Jam Nut Receptacle	43
FCTV Series (Composite Tri-Start, MIL-DTL-38999 Series III intermateable)		FBL Series IV (MIL-DTL-38999 Series IV intermateable)	
Design Features, Alternate Positions.....	9	Design Features, Alternate Positions	44
Wall Mounting Receptacle	10	Box Mounting Receptacle, Wall Mounting Receptacle	45
Jam Nut Receptacle.....	11	Box Mounting Receptacle (UTS crimp)	46
Box Mount Receptacle, printed circuit board mount	12	Wall Mounting Receptacle (UTS crimp).....	46
Jam Nut Receptacle, printed circuit board mount.....	13	FPT Series (MIL-C-26482 Series 1 intermateable)	
FTV Series (Tri-Start, MIL-DTL-38999 Series III intermateable)		Design Features, Alternate Positions	47
Design Features, Alternate Positions.....	14	Wall Mounting Receptacle	48
Wall Mounting Receptacle	15	Box Mounting Receptacle	49
Wall Mounting Receptacle (UTS crimp).....	16	Jam Nut Receptacle	50
Jam Nut Receptacle.....	17	Jam Nut Receptacle, minimum penetration.....	51
Jam Nut Receptacle (UTS crimp)	18	FPTE Wall Mounting Receptacle.....	52
Box Mount Receptacle, printed circuit board mount	19	FPTE Jam Nut Receptacle	53
Jam Nut Receptacle, printed circuit board mount	20	FAN Series (Filtered "AN") (MIL-DTL-5015 intermateable)	
FJT Series (MIL-DTL-38999 Series II intermateable)		Design Features, Alternate Positions	54
Design Features, Alternate Positions.....	21	Box Mounting Receptacle	55
Wall Mounting Receptacle	22	EMI/RFI Programmable Connectors	
Wall Mounting Receptacle, back panel mounting.....	23	Design Features	56
Box Mounting Receptacle	24	PFLJT Shell Styles	57
Box Mounting Receptacle, back panel mounting.....	25	PFTV Shell Styles.....	58
Jam Nut Receptacle.....	26	PFSJT Shell Styles	59
Jam Nut Receptacle, minimum penetration	27	Programmable Connectors How to Order	60
FLJT Series (MIL-DTL-38999 Series I intermateable)		Filter Adapters.....	61, 62
Design Features, Alternate Positions.....	28	Transient Protection, MOV – Metal Oxide Varistor Connectors	63, 64
Wall Mounting Receptacle	29	Transient Protection, Diode Connectors	65, 66
Wall Mounting Receptacle, back panel mounting (UTS crimp).....	30	Transient Protection, ESA – Energy Shunting Assembly.....	67
Box Mounting Receptacle	31	Filter Accessories.....	
Box Mounting Receptacle, back panel mounting (UTS crimp)	32	Universal Header Assembly for Flex Print or PC Board	
Box Mounting Receptacle, printed circuit board mount	33	Connectors	68, 69
Jam Nut Receptacle.....	34	Electrostatic Discharge (ESD) Protected Connectors	70
Jam Nut Receptacle (UTS crimp)	35	How to Order Filter Connectors	71, 72
Jam Nut Receptacle, printed circuit board mount.....	36	EMI Filter Check List (for assistance in ordering)	73
Jam Nut Receptacle, minimum penetration	37	Rectangular Filter Connectors from Amphenol Canada	74, 75
		EMI Filter/Transient Protection Specials.....	76
		Amphenol Sales Office and Distributor Listing	

For more assistance, contact your local Amphenol field sales office or:

Amphenol Aerospace
 40-60 Delaware Avenue, Sidney, NY 13838-1395
 Phone: 607-563-5011 or 800-678-0141
 Fax: 607-563-5157

NOTE: The connector products in this brochure were formerly known as Bendix® products. These products are now manufactured and sold under the Amphenol® brand name. The name "Amphenol" will replace the name "Bendix" on products and literature in the future.

Due to space limitations, metric equivalents of dimensional data in this catalog have not been included. All dimensions given may be converted to the metric system by the standard formula: dimension (inches) x 25.40 = dimension (millimeters).

Amphenol has the following and other patents which relate to the products described in this catalog:
 U.S. Patent 3,764,943, U.S. Patent 3,840,841, U.S. Patent 4,029,386, U.S. Patent 4,264,116, U.S. Patent 4,275,945, U.S. Patent 4,431,251, U.S. Patent 4,440,463, U.S. Patent 4,583,810, U.S. Patent 4,707,048, U.S. Patent 4,707,049, U.S. Patent 4,741,710, U.S. Patent 4,746,310, U.S. Patent 4,747,789, U.S. Patent 4,768,977, U.S. Patent 4,789,360, U.S. Patent 4,932,900, U.S. Patent 5,163,853, U.S. Patent 5,164,873, U.S. Patent 5,167,537, U.S. Patent 5,195,014, U.S. Patent 5,198,958, U.S. Patent 5,211,582
 Amphenol has additional patents pending, as well as patents and applications in other countries.

Amphenol Aerospace operates quality systems that are certified to ISO9001:2000 by third party registrars.

Amphenol® EMI/EMP Filter Protection Connectors

for protection of sensitive circuits

Amphenol® EMI/EMP Protection Connectors offer the versatility of standard connectors with EMI/EMP protection for sensitive circuits. Internal housing of the EMI/EMP devices eliminates costly and bulky exterior discrete protection devices.

Virtually all major MIL-Spec cylindricals can be incorporated with filter devices:

- MIL-DTL-38999
- MIL-DTL-5015
- MIL-C-26482
- MIL-C-27599
- MIL-C-83723
- MIL-C-26500

Amphenol offers filter connectors that include:

- EMP protection using diodes
- EMP protection utilizing metal oxide varistors (MOV's)
- Filtered plug connectors
- Filtered hermetic connectors
- Programmable filtered connectors with rear removable and rear insertable crimp contacts
- Filter connectors with ESD protection
- Combinations of filtering devices within one connector package

age

This catalog focuses on the cylindrical connector offerings from Amphenol with EMI/EMP filter transient protection.

There are also many rectangular filter connectors that are offered by Amphenol which include:

- MIL-DTL-24308 D-Sub
- MIL-DTL-83513 Micro D
- ARINC 404/600
- DOD-83527 Rack and Panel
- MIL-DTL-83733 Rack and Panel

Rectangular filter interconnects are manufactured and supplied by Amphenol Canada. See further information at the end of the catalog.

Advantages of Filter Connectors:

- Reduction in overall weight and space with the elimination of external filter circuits
- Reduction of solder junctions
- Increase in reliability due to fewer connections
- Fragile filter elements protected from handling and environmental damage

FTV
Subminiature Tri-Start,
• Pre-testing from factory and ready for installation

that are rear insertable and rear removable. Contacts can be replaced easily with standard

circuit boards.
MOV Connectors
MOV's act as a variable resistor to efficiently dis-

MIL-DTL-38999 Series III, Metal or Composite shells with Filter Protection.
FJT

M81969 insertion/removal tool.
FLJT
Subminiature LJT, MIL-DTL-38999

sipate energy. MOV can be packaged singularly or in combinations with other EMI Fil-

Subminiature JT, MIL-DTL-38999 Series II with Filter Protection.

Series I with Filter Protection.
FCTV with Stand-off Flange
Filtered Tri-Start connectors with composite shells for attachment to printed

tering.
Filter AN Connectors

Programmable Filter Connectors
With crimp contacts

MIL-DTL-5015 Type Connectors with Filter Protection.
FPT
Miniature MIL-C-26482 Series 1 with Filter Protection.
Header

EMI Capabilities

for maximum design flexibility

The Amphenol® EMI filter connector utilizes two manufacturing technologies to provide the user with the most cost effective performance across the frequency range. (For EMP performance data, see pages 63-66).

The tubular design offers over 40 years of proven field reliability. All filter contacts within the connector share a common ground plane, which is connected to the connector shell. The pin to pin isolation is 85 dB minimum at 100 MHz. The planar design joins pins to a multi-layered ceramic forming an array sub-assembly, with a peripheral ground which is connected to the connector shell via a ground spring. Pin to pin capacitance is less than 50 pf with a pin to pin isolation of 85 dB minimum at 100 MHz.

Filter contacts for both designs contain either a pi passive element network comprised of a ferrite inductor and ceramic capacitor, or a single capacitor.

For planar designs other filter networks are available, ie. T Type, L-C Type and C-L Type. An encapsulant of oven-cured epoxy in the rear provides:

- Mechanical and thermal insulation of the ceramic elements – mechanical loading can be accomplished without capacitor damage. Pins can be bent 90° and straightened with no damage to the filter.
- Hermeticity (4.6×10^{-3} cc/sec) – prevents water from entering through the rear of the connector in high humidity environments. Amphenol recommends using metal protection

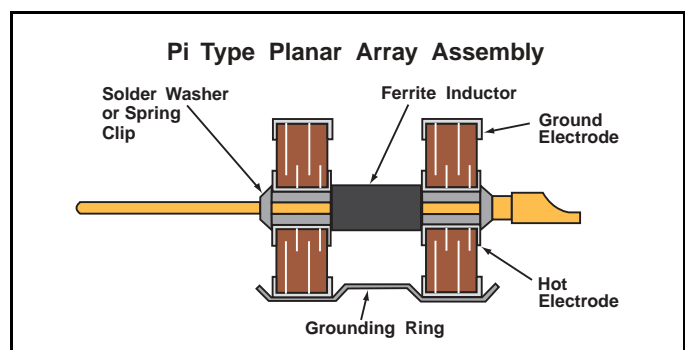
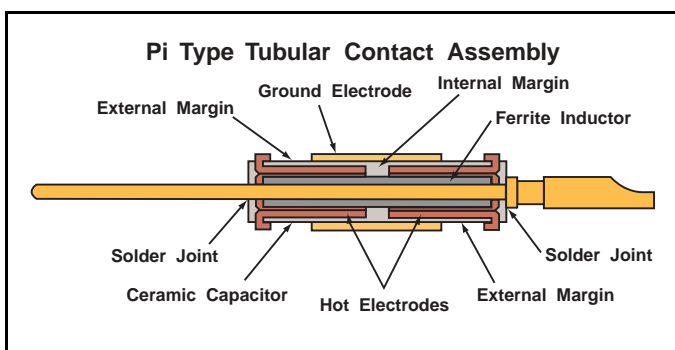
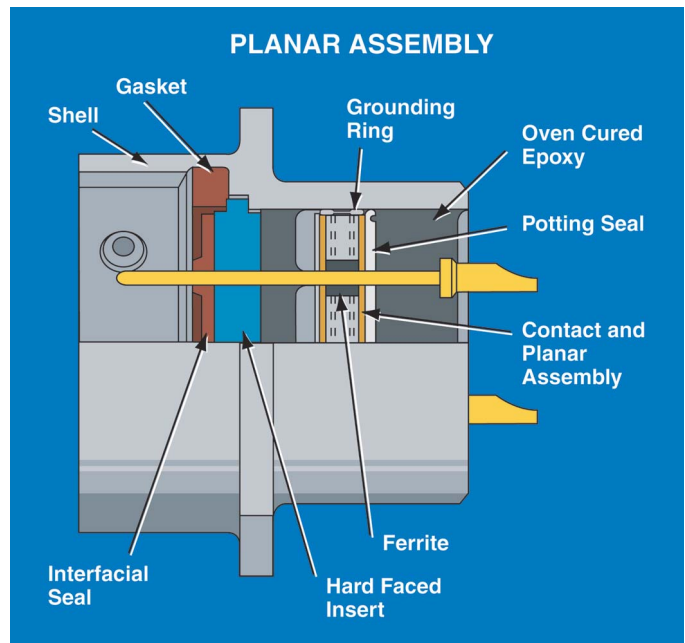
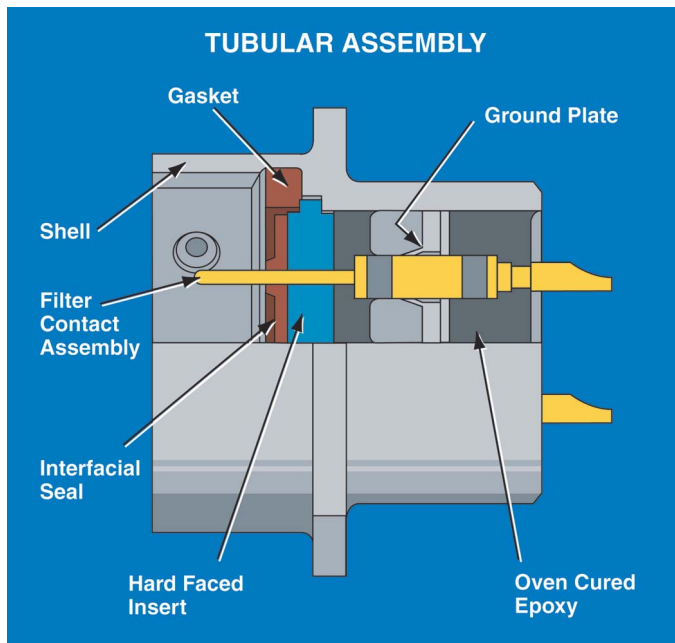

caps during cleaning operations.

* More in-depth information on attenuation is available in: L-1146, General Design Guideline for EMI Filters and/or TVS (Transient Voltage Suppression) Connectors. Also for further information ask for:

EMI Capabilities, cont.

Amphenol provides a wide range of filtering solutions. You can select your options for your particular interference threats - VHF, UHF, HF or other filter ranges, then couple with a connector package of your choice. Or give Amphenol your custom shell design requirements for assistance in designing your unique filter solution.

EMI Filter connectors are intended for use in temperatures from -55°C to $+125^{\circ}\text{C}$. Attenuation will change with feed-through current and temperature.*

To assure reliability, connectors may be subjected to an attenuation performance test verifying proper assembly and grounding of the filters. Attenuation data on filter performance is stated in reference to a 50 ohm impedance system in order to allow filter performance to be more easily translated into real world impedances.

Those interested in determining the expected filter performance in an impedance system other than 50 ohms may refer to page 7 of this catalog or may contact Amphenol Aerospace for further assistance.

It is suggested that the user analyze his system requirements for EMI protection in the following areas:

- Working voltage (DC or AC and Frequency)
- Peak voltage
- Desired attenuation at a given frequency level
- Any special capacitance limitations

Definition of Filter Contacts:

MF	Medium Frequency 50 dB performance between 300 - 2999 KHz
HF	High Frequency 50 dB performance between 3 - 29 MHz
VHF	Very High Frequency 50 dB performance between 30 - 2999 MHz
UHF	Ultra High Frequency 50 dB performance between 300 - 2999 MHz

Filter contacts can be provided in most frequencies in contact sizes 22 or larger. Consult Amphenol Aerospace for availability.

Tubular connector designs will meet 3 amps RF current from -55°C through $+125^{\circ}\text{C}$. Planar connector designs will meet 5 amps.

Planars, MOV's, Tubular and Diode Contacts

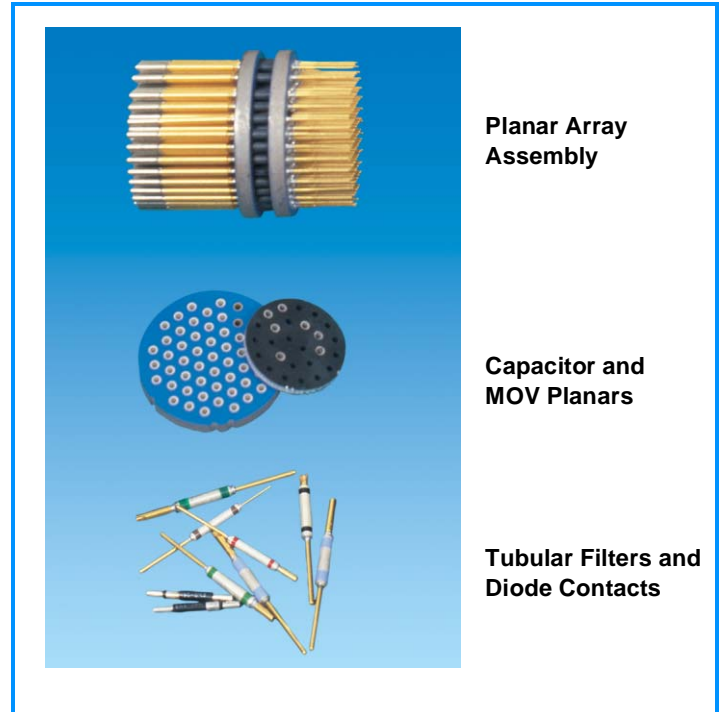

Planar Array Assembly

Capacitor and MOV Planars

Tubular Filters and Diode Contacts

Contact Options

- Coaxial, concentric twinax, triax and quadax contacts can be included in arrangements of filtered contacts for signal or power circuits (See Amphenol catalog 12-130, High Frequency Contacts for Multi-pin Connectors).
- Filter contacts with differing cutoff frequencies can be mixed in any given insert arrangement. (ratio 20:1 typical)
- Programmable filter connectors have crimp rear removable and rear insertable contacts. These provide benefits not available in fixed EMI/RFI connectors. Modifications of the EMI performance can be made simply with changing the contacts. (See pages 56-60)
- Ground, insulated or filter contacts can be combined within the same connector to meet unique or changing frequency protection requirements.
- Thermocouple contacts
- Diodes for EMP

Methods of Wire Termination

- Solder cup - wire termination
- PCB termination (Pre-tinning is available)
- Solderless wrap
- Amphenol® UTS (Universal Termination System) allows crimp termination. It uses crimp insertable socket contacts on conductor wires. Sockets mate with filter pins within the connector body. (Socket type M39029/57). (For further contact information, see catalog 12-090, MIL-DTL-38999 Series I & II).
- Weld terminal for thermocouple contacts

Filter Connector Options

Other Filter Connector Options include:

- Plug shells with grounding fingers for shielding against external EMI. (See page 76).
- Filter adapters eliminate replacement of either existing mated pair. The adapter provides the circuit protection at the MF, VHF and UHF levels, and is an effective and economical method of introducing EMI/EMP protection to an installed system. Adapters are to be placed between mating faces. (See pages 61, 62).
- Receptacle shell modifications that allow mounting directly to a PC board or flex header. Stand-off shells are available in different configurations. These offer improved reliability by eliminating external spacers and washers. (See pages 10).
- The hermetic filter connector, while only approximately 1/2 inch longer than standard series connectors, provides all the benefits of a hermetic connector, plus EMI protection for sensitive circuits. The filter assembly is protected by a fused glass insert within a unique steel housing. This design provides the capability to tolerate high level static pressure while maintaining a low level leakage rate. Consult Amphenol Aerospace for more information.
- Composite shell filter connectors meet the MIL-DTL-38999, Series III dimensional length, and offer a light-weight, corrosion resistant, durable connector with the same high performance features as its metal counterpart. The composite filter connector utilizes planar technology to accommodate VHF-1 or better electrical performance characteristics. (See pages 9-13).
- Filter connectors with ESD (Electrostatic Discharge) protection are available. These MIL-DTL-38999 Series III connectors have an added feature of a Faraday Cage to shunt electrostatic discharge events to the conductive enclosure on which the connector is mounted. (See page 70).
- Filtered Plugs are designed for applications where EMI protection is essential, but access to the receptacle is denied. Designed with the same components as a standard filter receptacle, the filtered plug offers the option of being mounted on the cable harness. It is a cost effective method of achieving EMI protection when length restrictions prohibit inclusion of an adapter to the system. Consult Amphenol Aerospace for availability.
- Diode Connectors offers versatility with transient protection for sensitive circuits, such as TTL lines. Diodes can stand alone or be combined with other filters. (Pages 65, 66).
- Receptacles with EMP protection are available for MIL-DTL-38999 Series IV. (Pages 44-46).
- Amphenol's Energy Shunting Assembly is a simple, compact unit which provides lightning and electromagnetic pulse protection of systems in which many signal lines enter sensitive electronic equipment. (Page 67).



Cylindrical Filter Protection Connectors are offered in a wide range of styles, with custom designs for special applications.



Filter Adapters can be attached to connectors to provide EMI/EMP protection.



Hermetic filter connector

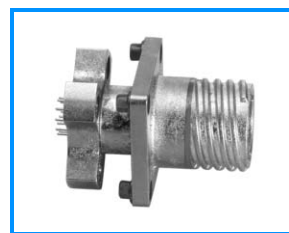

Composite shell stand-off Filter 38999 connector

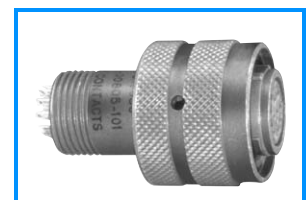

Filtered plug



Diode Connectors



ESA - Energy Shunting Assembly

Filter Selection Data

Amphenol® EMI Connectors are produced with several types of filters. They are all low band pass filters with the following configurations:

Pi -

Typical of the VHF, UHF and MF filter

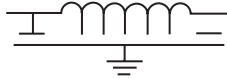

Cascaded Pi -

Typical of the HF filter. It consists of two VHF Pi filters on a common pin and is available in tubular designs only.

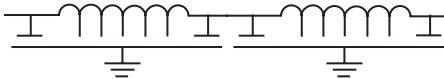

Capacitor *-

Consists of a feed-through capacitor without any ferrite. It can be 50pf to 1µf and carry the MF, HF and VHF designation depending on its typical 50dB performance.

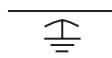

L-C *-

Typical of HF, VHF and UHF filter. Low source / high load impedance.



C-L *-

Typical of HF, VHF and UHF filter. High load impedance / low source.



T *-

Typical of HF, VHF and UHF filter. Low source / low load impedance.



* Consult factory for attenuation performance values.

Parameters		Medium Frequency Filter	High Frequency Filter	Very High Frequency Filter		Ultra High Frequency Filter	
		MF1 (Pi)	HF1 (Cascaded Pi)	VHF1 (Pi)	VHF2† (Pi)	UHF1† (Pi)	UHF2† (Pi)
Minimum Attenuation (Test Points)*	150kHz	20dB	-	-	-	-	-
	15MHz	-	50dB	-	-	-	-
	50MHz	-	80dB	-	-	-	-
	100MHz	80dB	-	62dB	46dB	18dB	28dB
Maximum Working Voltage (User must specify DC or AC)†††	DC†††	50VDC	200VDC	200VDC	200VDC	200VDC	200VDC
Dielectric Withstanding Voltage Capability (for 5 sec. with 10 milliamperes max. charging current)◆◆		100 volts DC	500 volts DC	500 volts DC	500 volts DC	500 volts DC	500 volts DC
Maximum Feed-thru Current (DC and/or Audio Frequency R.M.S.)	Size 16 contacts	13.0 amps	13.0 amps	13.0 amps	13.0 amps	13.0 amps	13.0 amps
	Size 20 contacts	7.5 amps	7.5 amps	7.5 amps	7.5 amps	7.5 amps	7.5 amps
	Size 22 contacts	not available	not available	5.0 amps	5.0 amps	5.0 amps	5.0 amps
Maximum RF Current		3.0 amps	3.0 amps	3.0 amps	3.0 amps	3.0 amps	3.0 amps
Minimum Insulation Resistance**		250 megohms	10 gigaohms	10 gigaohms	10 gigaohms	10 gigaohms	10 gigaohms
Typical Capacitance***		1.0 microfarad	16 nanofarads	7 nanofarads	2.5 nanofarads	375 picofarads	710 picofarads
Air Leakage††		4.6 x 10 ⁻³ cc/sec					
Operating Temperature Range		-55°C to +125°C					

- * When tested at 25°C per MIL-STD-220.
- ** After 2 minutes at working DC voltage through a protective resistance of 1 megohm when measured between contact and ground at +25°C.
- *** When measured at a frequency of 1 ±.1kHz and a voltage not exceeding 1.0 V.A.C.R.M.S. at +25°C.
- † Consult Amphenol, Sidney, NY or your Amphenol representative for part number.
- †† Lower leakage rates are available upon request.
- ††† Summation of the DC and low level AC super-imposed peak voltage.
- †††† Consult Amphenol, Sidney, NY whenever AC voltage is present.
- ◆ Consult Amphenol, Sidney, NY or your Amphenol representative for availability.
- ◆◆ Higher DWV ratings are available upon request. Consult Amphenol, Sidney, NY.

Effect of Temperature on EMI Filter Attenuation

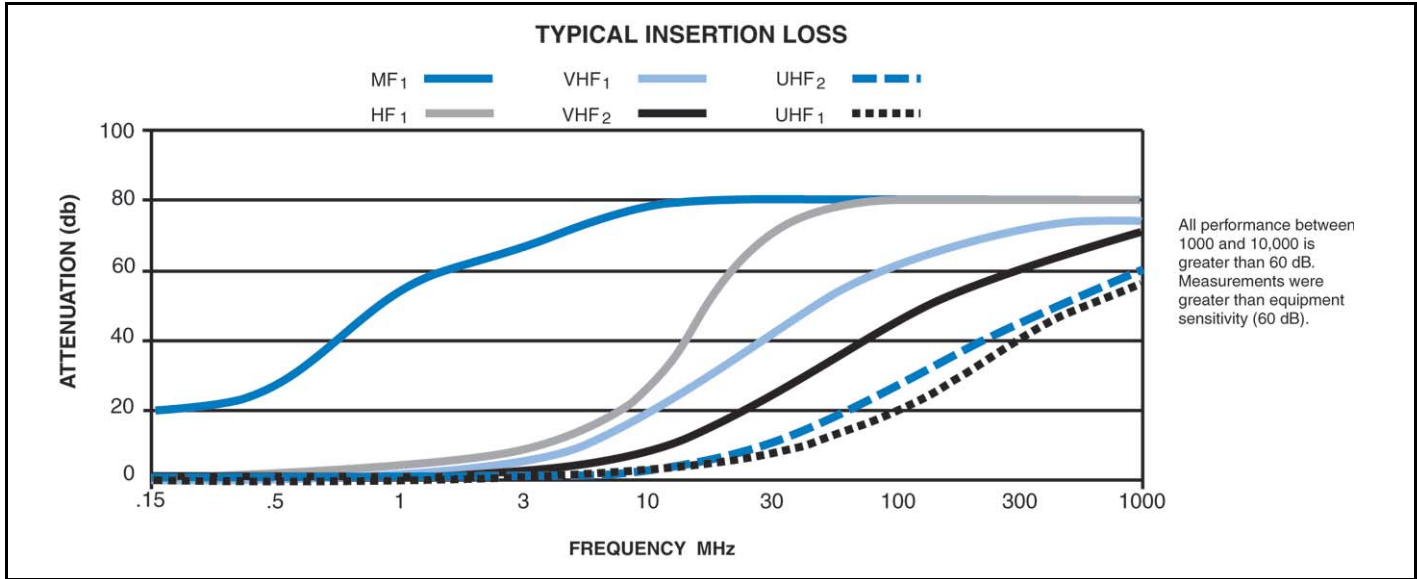

**TYPICAL INSERTION LOSS (dB)
PER MIL-STD-220, 5 ADC, 25°C**

Capacitance	1MHz	3MHz	10MHz	30MHz	100MHz	300MHz	1000MHz
375 pf UHF ₁	0	0	1	8	16	–	–
750 pf UHF ₂	0	0	3	10	19	–	–
2500 pf VHF ₂	0	2	8	20	28	–	–
7000 pf VHF ₁	5	9	17	23	40	–	–
16000 pf HF ₁	6	14	20	24	80	–	–

Most filter attenuation curves and capacitance values are expressed at 25°C. However, temperature can affect the capacitance of a titanate filter element, affecting the insertion loss that the element will cause.

In order to assist the user in anticipating the effect of various temperatures, the following charts applicable to Amphenol® filter connectors utilizing MF₁, HF₁, VHF₁, VHF₂, UHF₁ and UHF₂ filters are provided. Please note that all insertion loss (attenuation) values given were measured with no load applied. The band designations refer to MIL-STD-2120.

MF₁*

Typical Capacitance = 1,000,000 pf Min. 800,000 pf Max. 1,600,000 pf
Type Pi

Temp.	F _{CO}	1MHz	3MHz	10MHz	30MHz	100MHz	300MHz	1000MHz
-55°C	–	18	–	64	80	80	80	80
Room	7.94K	55	–	80	80	80	80	80
+125°C	–	22	–	70	80	80	80	80

VHF₂

Typical Capacitance = 2,500 pf Min. 1,900 pf Max. 4,000 pf
Band E, Type Pi

Temp.	F _{CO}	1MHz	3MHz	10MHz	30MHz	100MHz	300MHz	1000MHz
-55°C	–	0	2	7	17	40	58	71
Room	3.3M	0	2	8	24	46	61	71
+125°C	–	0	3	10	26	46	63	69

HF₁*

Typical Capacitance = 16,000 pf Min. 9,800 pf Max. 24,000 pf
Type Cascaded Pi

Temp.	F _{CO}	1MHz	3MHz	15MHz	50MHz	100MHz	300MHz	1000MHz
-55°C	–	2	6	24	62	80	80	80
Room	648K	3	9	50	80	80	80	80
+125°C	–	0	6	30	62	80	80	80

UHF₂

Typical Capacitance = 750 pf Min. 500 pf Max. 1,100 pf
Band C, Type Pi

Temp.	F _{CO}	1MHz	3MHz	10MHz	30MHz	100MHz	300MHz	1000MHz
-55°C	–	0	0	3	9	25	46	61
Room	12.7M	0	0	3	10	28	46	61
+125°C	–	0	0	3	10	24	42	60

VHF₁

Typical Capacitance = 7,000 pf Min. 4,900 pf Max. 12,000 pf
Band G, Type Pi

Temp.	F _{CO}	1MHz	3MHz	10MHz	30MHz	100MHz	300MHz	1000MHz
-55°C	–	1	2	8	21	44	61	65
Room	1.27M	1	6	18	42	62	72	75
+125°C	–	0	2	9	24	45	62	64

UHF₁

Typical Capacitance = 375 pf Min. 290 pf Max. 450 pf
Band B, Type Pi

Temp.	F _{CO}	1MHz	3MHz	10MHz	30MHz	100MHz	300MHz	1000MHz
-55°C	–	0	0	1	6	21	43	58
Room	21.9M	0	0	1	8	18	42	56
+125°C	–	0	0	1	8	17	38	50

Note: F_{CO} = Cut-off Frequency

* Consult Amphenol, Sidney, NY for availability.

Impedance Matching Formula (your system to a 50 ohm system)

The following formula and example are offered in order to determine the expected filter performance in an impedance system other than 50 ohms.

With the attenuation expressed in 50 ohms and the transfer impedance curve shown in Figure 1 below, a designer can relate the expressed attenuation to the input and output impedance of his circuit.

Example:

- (1) Noise is 40dB above specification level at 100 MHz
- (2) Input and output impedance are 10 and 100 ohms respectively
- (3) Amphenol® VHF 7000 pf filter has a 65 dB minimum attenuation at 100 MHz and +25°C

Formula (Taken from Figure 1):

$1.4 \times 10^2 \Omega$ = transfer impedance
for 65 dB in a 50 ohm system

$$\text{Atten (dB)} = 20 \log_{10} \left[1 + \frac{Z_S Z_L}{Z_{12}(Z_S + Z_L)} \right]$$

Z_S = source impedance

Z_L = load impedance

Z_{12} = transfer impedance

Atten = filter performance in a system other than 50 ohms

$$\text{Atten (dB)} = 20 \log_{10} \left[1 + \frac{10(100)}{1.4 \times 10^{-2} (10 + 100)} \right]$$

Attenuation = 56.3dB

In this case, the 7000 pf VHF filter will give 56.3 dB which is 16.3dB below the desired reduction in noise (40dB) as stated in the above problem.

Attenuation vs Transfer Impedance in 50 Ohm System

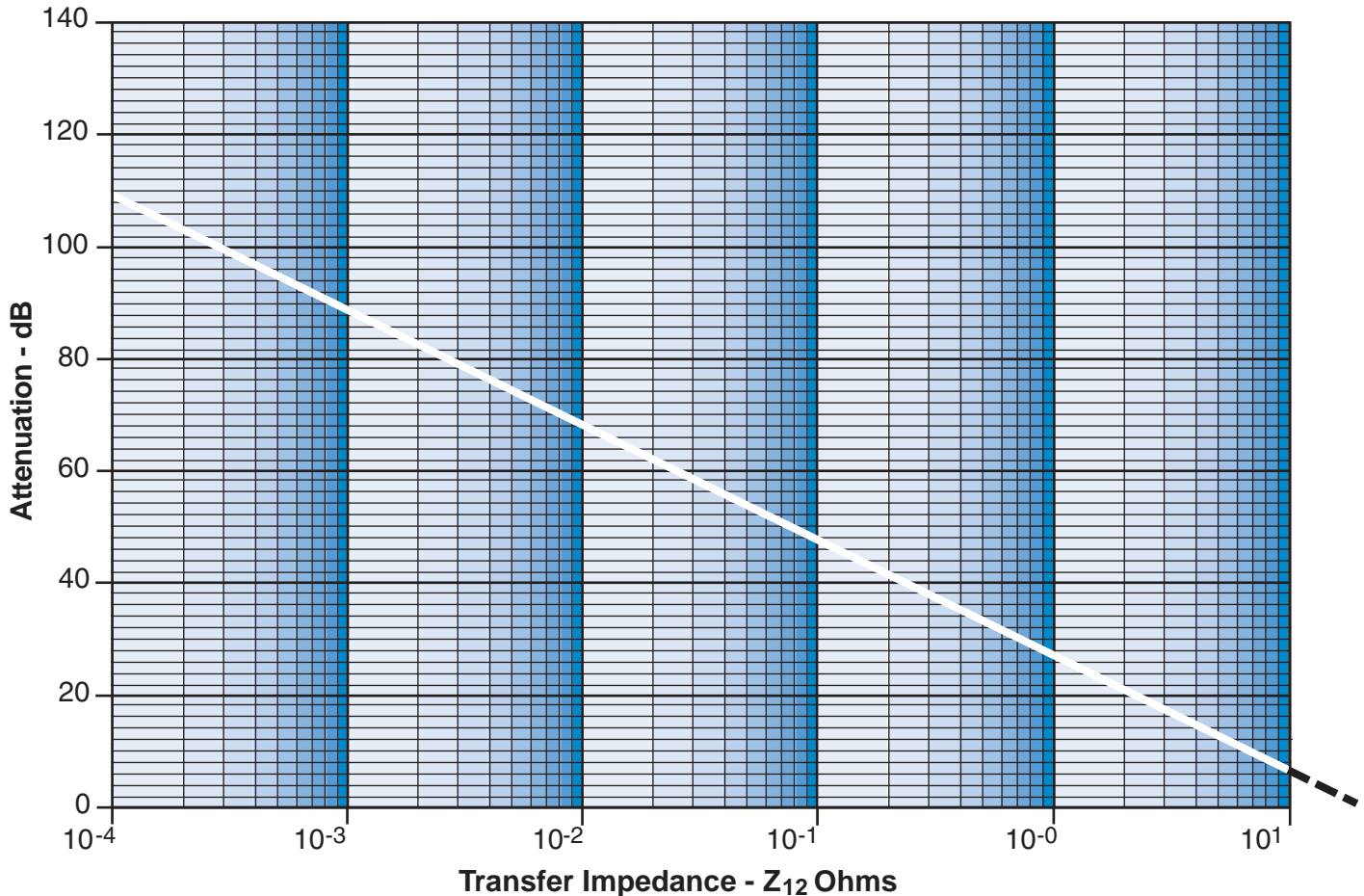

Figure 1

Quality Assurance Testing

ACCEPTANCE TESTING

All filter connectors undergo extensive acceptance testing to assure product quality. An outline of standard acceptance testing performed is as follows:

Mechanical Inspection

- Dimensional inspection of shells, keys, keyways and mounting surfaces by either in-process inspection of components or inspection of final assemblies.
- Visual inspection of contacts, inserts and seals, gaskets and surface finish of shells and hardware.

Electrical Tests

- Insulation resistance of filter contacts is checked 100% at the working voltage and to the test limit listed for each filter in the filter selection data table.
- Dielectric withstanding voltage is tested on 100% of filter contacts at the voltage listed in the filter selection data table.
- Capacitance is tested 100% at 1KHz.

Special Tests/Processes

In addition to the standard acceptance testing and processes, the following additional production testing and processing can be provided upon request:

- Attenuation testing (through 100 MHz)
- Leakage inspection
- Thermal cycling/shock
- Burn-in
- De-gassing

Consult Amphenol Aerospace for further information.

Qualifications

Amphenol® filter connectors have been qualified and are on periodic requalification to specification BSF-1 (available from your Amphenol representative). This is patterned after MIL-DTL-38999, modified to include mechanical and environmental testing and electrical parameters important to filter connector performance.

These acceptance tests, along with exhaustive in-process inspection and testing, give Amphenol® filter connectors their reputation for reliability.

ATTENUATION TEST CIRCUIT

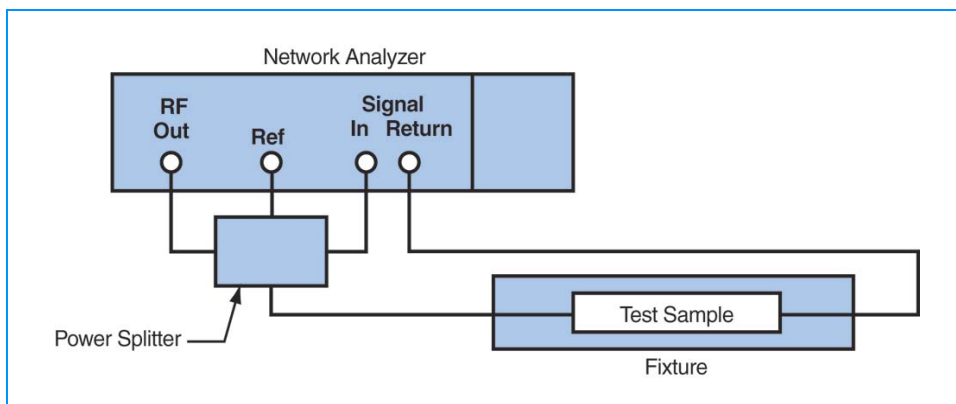

There are multiple test stations located on the Amphenol production floor that support all in-process, final electric and qualification testing as necessary.

Amphenol® FCTV Series Composite Tri-Start™ Subminiature Cylindrical Filters

The Amphenol® FCTV Series is the Composite Tri-Start with filtering for EMI/EMP protection. It offers the same high performance as its metal counterpart, the FTV, but with a lightweight, corrosion resistance shell.

- Intermateable with MIL-DTL-38999 Series III connectors (See Catalog 12-092)
- Quick Mating - completely mates in a 360° turn of the coupling nut
- Lockwiring Eliminated - incorporates anti-decoupling device
- Contact Protection - 100% "scoop-proof"
- Improved Moisture Resistance - prevents electrolytic erosion of contacts
- Lightweight Composite shell - 17% – 70% weight savings over metal
- Corrosion Resistant - available in standard MIL-DTL-38999 olive drab cadmium (175°C) and electroless nickel plating (200°C), both withstanding 2000 hours of salt spray exposure. The base material is able to withstand an indefinite exposure to salt spray.
- Durability - 1500 couplings minimum (in reference to connector couplings, not contacts)

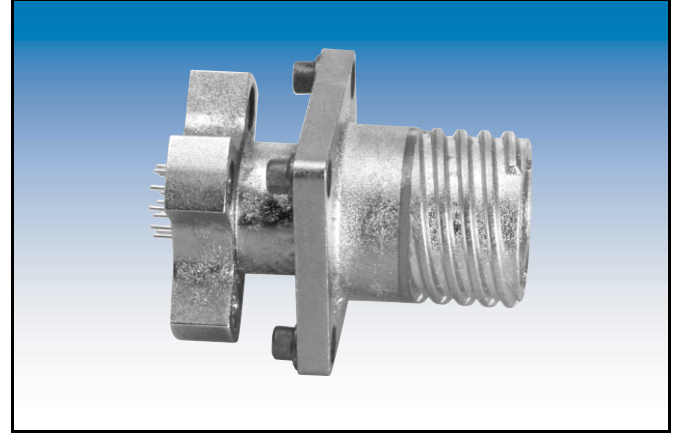

Composite FCTV Connector for PCB board mounting. Amphenol is currently the only supplier of one-piece composite PCB stand-off shells.

FCTV Master Key/Keyway Rotation

Shell Size	Key & Keyway arrangement identification letter	AR° or AP° BSC	BR° or BP° BSC	CR° or CP° BSC	DR° or DP° BSC
9	N	105	140	215	265
	A	102	132	248	320
	B	80	118	230	312
	C	35	140	205	275
	D	64	155	234	304
	E	91	131	197	240
11, 13, 15	N	95	141	208	236
	A	113	156	182	292
	B	90	145	195	252
	C	53	156	220	255
	D	119	146	176	298
	E	51	141	184	242
17 and 19	N	80	142	196	293
	A	135	170	200	310
	B	49	169	200	244
	C	66	140	200	257
	D	62	145	180	280
	E	79	153	197	272
21, 23, 25	N	80	142	196	293
	A	135	170	200	310
	B	49	169	200	244
	C	66	140	200	257
	D	62	145	180	280
	E	79	153	197	272

All angles are BSC
The insert arrangement does not rotate with main key/keyway.

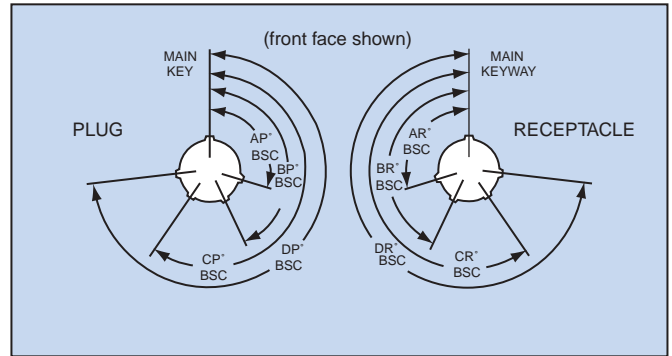

wall mounting receptacle

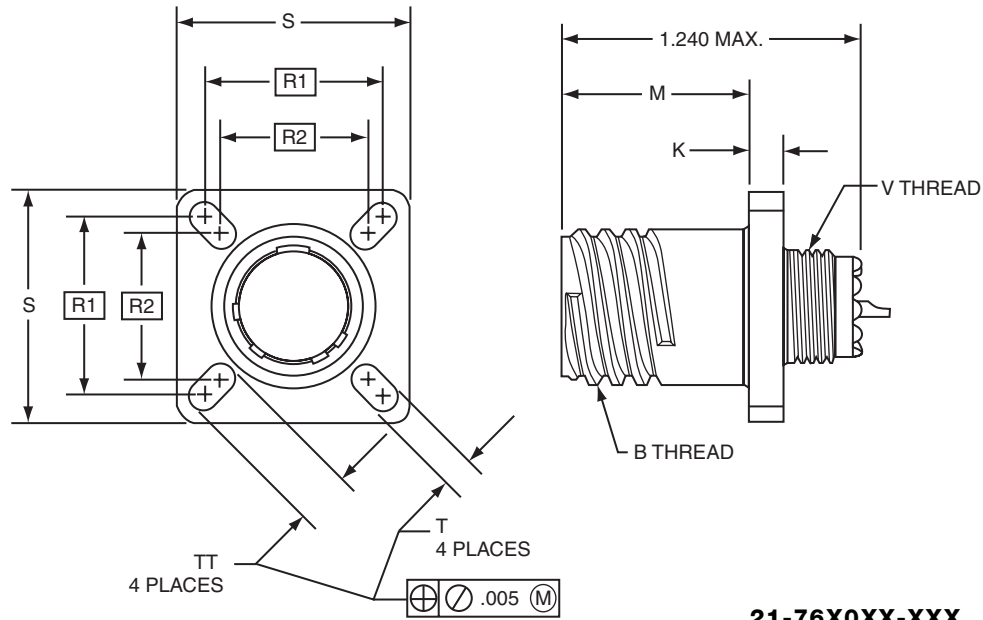

21-76X0XX-XXX

For ordering information see how to order page 72.

Shell Size	B Thread Class 2A 0.1P-0.3L-TS (Plated)	M +.000 -.005	K ±.0025	R ¹ TP	R ² TP	S +.011 -.010	T +.008 -.006	TT +.008 -.006	V Thread Metric (Plated)
9	.6250	.773	.1378	.719	.594	.938	.128	.216	M12X1-6g0.100R
11	.7500	.773	.1378	.812	.719	1.031	.128	.194	M15X1-6g0.100R
13	.8750	.773	.1378	.906	.812	1.125	.128	.194	M18X1-6g0.100R
15	1.0000	.773	.1378	.969	.906	1.219	.128	.173	M22X1-6g0.100R
17	1.1875	.773	.1378	1.062	.969	1.312	.128	.194	M25X1-6g0.100R
19	1.2500	.773	.1378	1.156	1.062	1.438	.128	.194	M28X1-6g0.100R
21	1.3750	.741	.1654	1.250	1.156	1.562	.128	.194	M31X1-6g0.100R
23	1.5000	.741	.1654	1.375	1.250	1.688	.154	.242	M34X1-6g0.100R
25	1.6250	.741	.1654	1.500	1.375	1.812	.154	.242	M37X1-6g0.100R

All dimensions for reference only.

jam nut receptacle

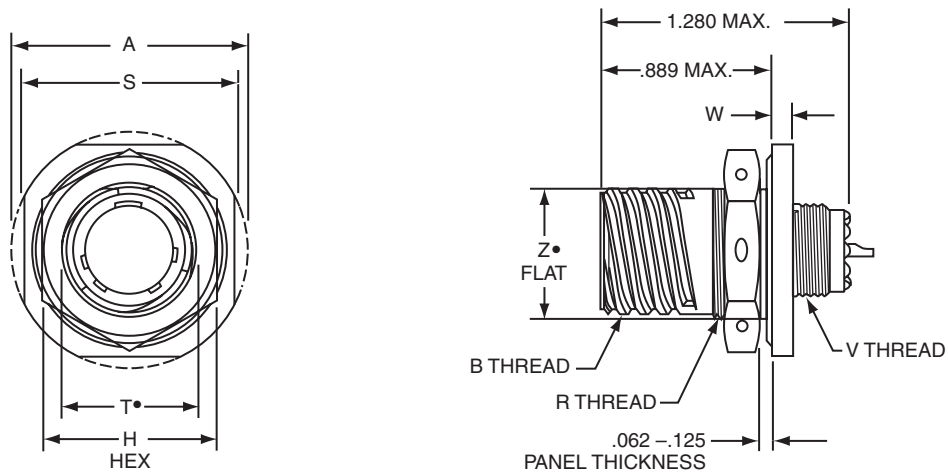

21-76X7XX-XXX

- D shaped mounting hole dimensions
For ordering information see how to order page 72.

Shell Size	A Dia. ±.010	B Thread Class 2A 0.1P-0.3L-TS (Plated)	H Hex +.017 -.016	R Thread Metric (Plated)	S ±.015	T* +.010 -.000	V Thread Metric (Plated)	W +.035 -.004	Z* Flat +.000 -.010
9	1.188	.6250	.875	M17X1-6g0.100R	1.062	.697	M12X1-6g0.100R	.086	.669
11	1.375	.7500	1.000	M20X1-6g0.100R	1.250	.822	M15X1-6g0.100R	.086	.769
13	1.500	.8750	1.188	M25X1-6g0.100R	1.375	1.007	M18X1-6g0.100R	.086	.955
15	1.625	1.0000	1.312	M28X1-6g0.100R	1.500	1.134	M22X1-6g0.100R	.086	1.084
17	1.750	1.1875	1.438	M32X1-6g0.100R	1.625	1.259	M25X1-6g0.100R	.086	1.208
19	1.937	1.2500	1.562	M35X1-6g0.100R	1.812	1.384	M28X1-6g0.100R	.118	1.333
21	2.062	1.3750	1.688	M38X1-6g0.100R	1.938	1.507	M31X1-6g0.100R	.118	1.459
23	2.188	1.5000	1.812	M41X1-6g0.100R	2.062	1.634	M34X1-6g0.100R	.118	1.575
25	2.312	1.6250	2.000	M44X1-6g0.100R	2.188	1.759	M37X1-6g0.100R	.118	1.709

All dimensions for reference only.

box mount receptacle (printed circuit board mount)

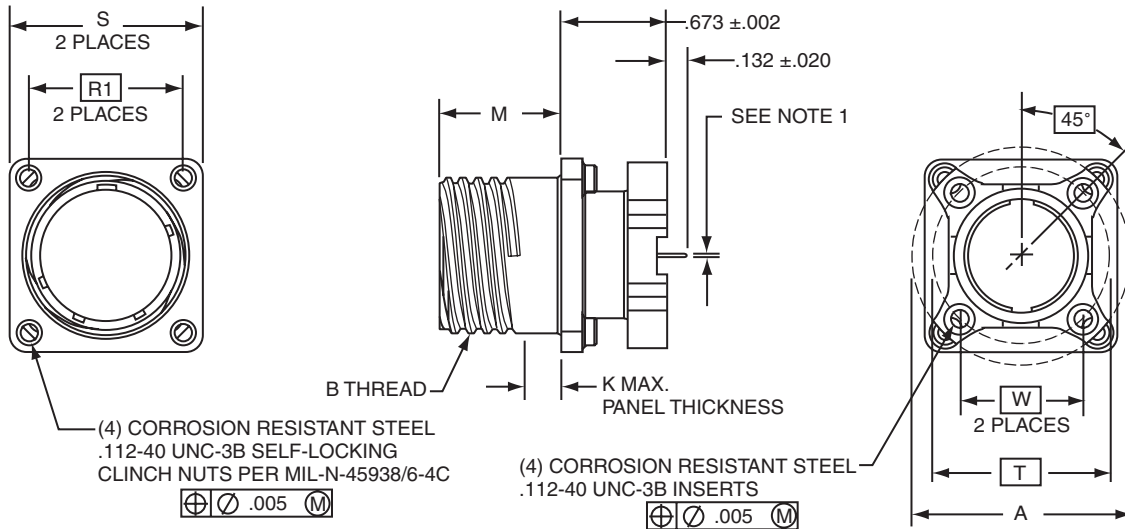

21-78X2XX-XXX

- Standard tail for size 22 is $.020 \pm .001$ dia.
Standard tail for size 20 is $.030 \pm .001$ dia.
For ordering information, see how to order page 72.

Shell Size	A Dia. $\pm .005$	B Thread Class 2A 0.1P-0.3L-TS (Plated)	M $+.000$ $-.005$	K Max. Panel Thickness	R ¹ TP	S $+.011$ $-.010$	PCB Mounting Dimensions	
							T Dia. TP	W TP
9	1.016	.6250	.773	.234	.719	.938	.752	.532
11	1.062	.7500	.773	.234	.812	1.031	.850	.601
13	1.250	.8750	.773	.234	.906	1.125	.994	.703
15	1.375	1.0000	.773	.234	.969	1.219	1.119	.791
17	1.500	1.1875	.773	.234	1.062	1.312	1.237	.875
19	1.625	1.2500	.773	.234	1.156	1.438	1.379	.975
21	1.750	1.3750	.741	.204	1.250	1.562	1.489	1.053
23	1.875	1.5000	.741	.204	1.375	1.688	1.619	1.145
25	2.000	1.6250	.741	.204	1.500	1.812	1.744	1.233

All dimensions for reference only.

jam nut receptacle (printed circuit board mount)

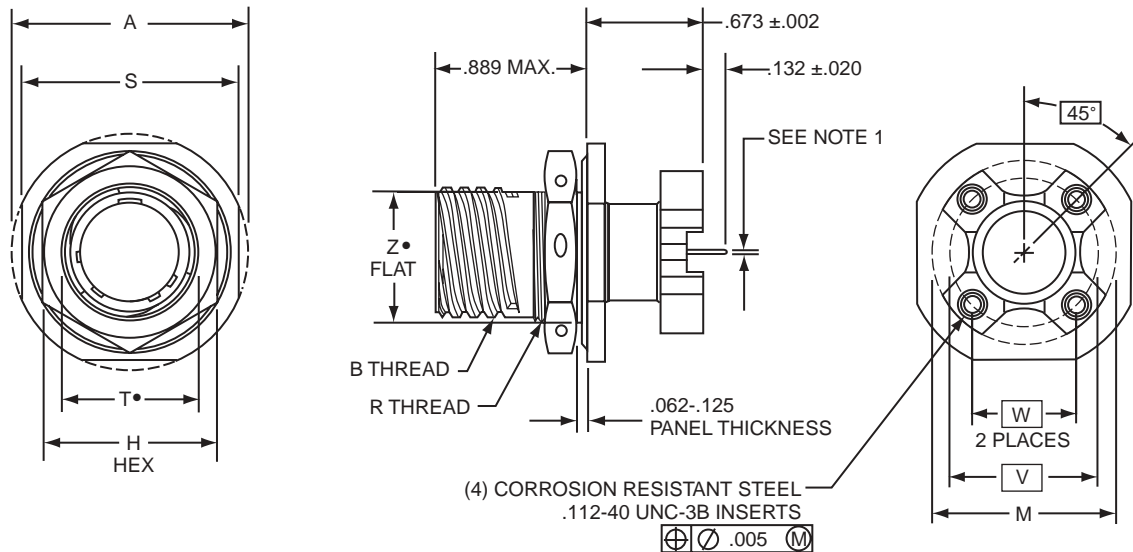

21-78X7XX-XXX

- Standard tail for size 22 is .020±.001
Standard tail for size 20 is .030±.001
 - "D" shaped mounting hole dimensions
- For ordering information see how to order page 72.

Shell Size	A Dia. ±.005	B Thread Class 2A 0.1P-0.3L-TS (Plated)	H Hex +.017 - .016	M Dia. ±.005	R Thread Metric (Plated)	S +.011 - .010	T Dia. +.010 - .000	PCB Mounting Dimensions		Z Flat +.000 - .010
								W TP	V Dia. TP	
9	1.188	.6250	.875	1.016	M17X1-6g0.100R	1.062	.697	.532	.752	.669
11	1.375	.7500	1.000	1.062	M20X1-6g0.100R	1.250	.822	.601	.850	.769
13	1.500	.8750	1.188	1.250	M25X1-6g0.100R	1.375	1.007	.703	.994	.955
15	1.625	1.0000	1.312	1.375	M28X1-6g0.100R	1.500	1.134	.791	1.119	1.084
17	1.750	1.1875	1.438	1.500	M32X1-6g0.100R	1.625	1.259	.875	1.237	1.208
19	1.937	1.2500	1.562	1.625	M35X1-6g0.100R	1.812	1.384	.975	1.379	1.333
21	2.062	1.3750	1.688	1.750	M38X1-6g0.100R	1.937	1.507	1.053	1.489	1.459
23	2.188	1.5000	1.812	1.875	M41X1-6g0.100R	2.062	1.634	1.145	1.619	1.575
25	2.312	1.6250	2.000	2.000	M44X1-6g0.100R	2.188	1.759	1.233	1.744	1.709

All dimensions for reference only.

Amphenol® FTV Series Tri-Start™ Subminiature Cylindrical Filters

The Amphenol® FTV Series demonstrates unsurpassed technical leadership. With the added feature of the filter, this high performance general duty threaded connector is designed to withstand the pressures of severe environment applications.

- Intermateable with MIL-DTL-38999 Series III connectors (see Catalog 12-092)
- Quick Mating – completely mates in a 360° turn of the coupling nut
- Lockwiring Eliminated – incorporates anti-decoupling device
- Contact Protection – 100% “scoop-proof”
- Improved Moisture Resistance – prevents electrolytic erosion of contacts
- Corrosion Resistant – 500 hour salt spray olive drab cadmium over nickel plating, class RW, or stainless steel shells



FTV Master Key/Keyway Rotation

Shell Size	Key & Keyway arrangement identification letter	AR° or AP° BSC	BR° or BP° BSC	CR° or CP° BSC	DR° or DP° BSC
9	N	105	140	215	265
	A	102	132	248	320
	B	80	118	230	312
	C	35	140	205	275
	D	64	155	234	304
	E	91	131	197	240
11, 13, 15	N	95	141	208	236
	A	113	156	182	292
	B	90	145	195	252
	C	53	156	220	255
	D	119	146	176	298
	E	51	141	184	242
17 and 19	N	80	142	196	293
	A	135	170	200	310
	B	49	169	200	244
	C	66	140	200	257
	D	62	145	180	280
	E	79	153	197	272
21, 23, 25	N	80	142	196	293
	A	135	170	200	310
	B	49	169	200	244
	C	66	140	200	257
	D	62	145	180	280
	E	79	153	197	272

All angles are BSC
The insert arrangement does not rotate with main key/keyway.

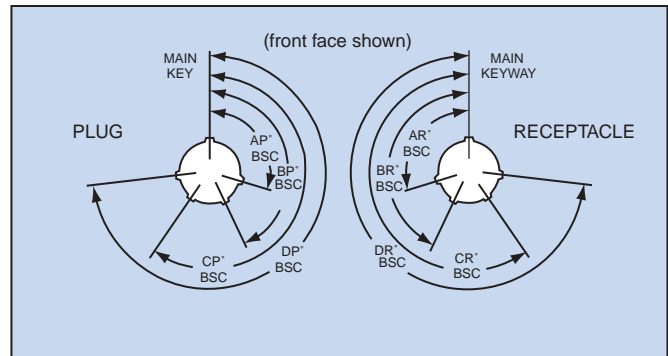

wall mounting receptacle

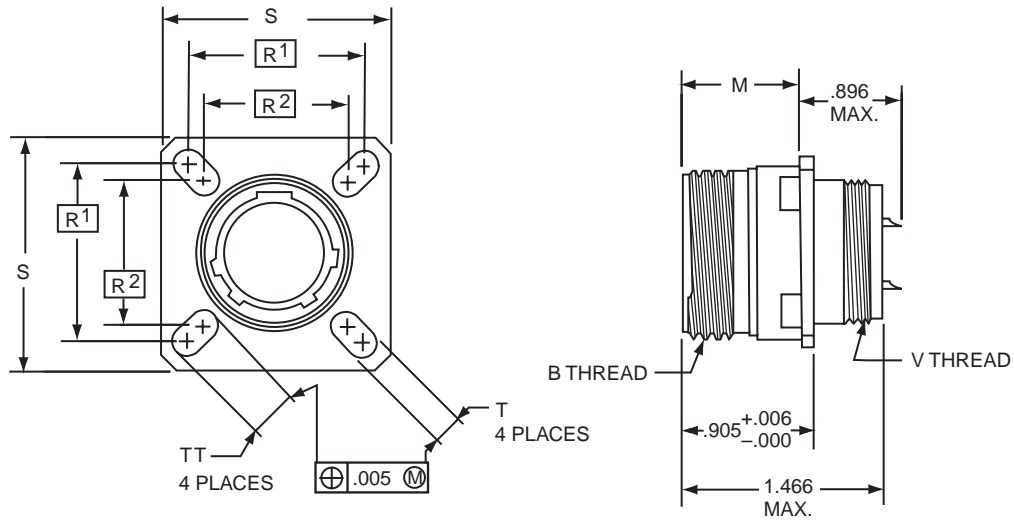

21-52X0XX-XXX

For ordering information, see how to order page 72.
 Plug movement required to clear FTV receptacles: .625 min.

Shell Size	B Thread Class 2A 0.1P-0.3L-TS (Plated)	M $^{+.000}_{-.005}$	R ¹ TP	R ² TP	S $\pm .010$	T $^{+.008}_{-.006}$	V Thread Metric (Plated)	TT $^{+.008}_{-.006}$
9	.6250	.820	.719	.594	.938	.128	M12X1-6g0.100R	.216
11	.7500	.820	.812	.719	1.031	.128	M15X1-6g0.100R	.194
13	.8750	.820	.906	.812	1.125	.128	M18X1-6g0.100R	.194
15	1.0000	.820	.969	.906	1.219	.128	M22X1-6g0.100R	.173
17	1.1875	.820	1.062	.969	1.312	.128	M25X1-6g0.100R	.194
19	1.2500	.820	1.156	1.062	1.438	.128	M28X1-6g0.100R	.194
21	1.3750	.790	1.250	1.156	1.562	.128	M31X1-6g0.100R	.194
23	1.5000	.790	1.375	1.250	1.688	.154	M34X1-6g0.100R	.242
25	1.6250	.790	1.500	1.375	1.812	.154	M37X1-6g0.100R	.242

All dimensions for reference only.

wall mounting receptacle (UTS crimp)

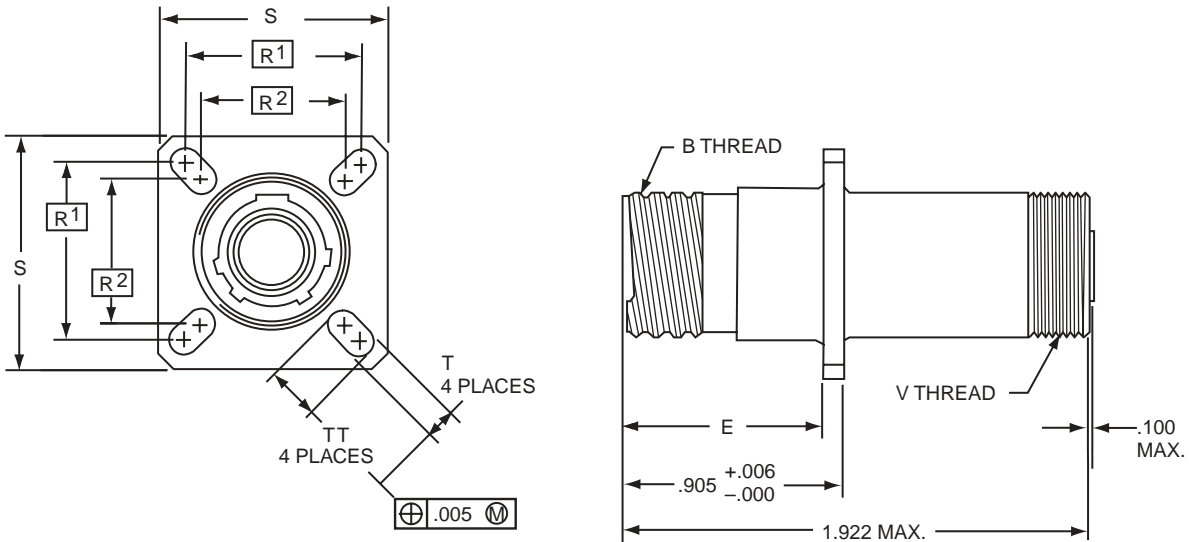

**21-50X0XX-XXX
UTS (Crimp) Contact
MIL-C-39029/57**

For ordering information, see how to order page 72.

Shell Size	B Thread Class 2A 0.1P-0.3L-TS (Plated)	E $+.000$ $-.005$	R ¹ TP	R ² TP	S $\pm .010$	T $+.008$ $-.006$	V Thread Metric (Plated)	TT $+.008$ $-.006$
9	.6250	.820	.719	.594	.938	.128	M15X1-6g0.100R	.216
11	.7500	.820	.812	.719	1.031	.128	M18X1-6g0.100R	.194
13	.8750	.820	.906	.812	1.125	.128	M22X1-6g0.100R	.194
15	1.0000	.820	.969	.906	1.219	.128	M25X1-6g0.100R	.173
17	1.1875	.820	1.062	.969	1.312	.128	M28X1-6g0.100R	.194
19	1.2500	.820	1.156	1.062	1.438	.128	M31X1-6g0.100R	.194
21	1.3750	.790	1.250	1.156	1.562	.128	M34X1-6g0.100R	.194
23	1.5000	.790	1.375	1.250	1.688	.154	M37X1-6g0.100R	.242
25	1.6250	.790	1.500	1.375	1.812	.154	M41X1-6g0.100R	.242

All dimensions for reference only.

jam nut receptacle

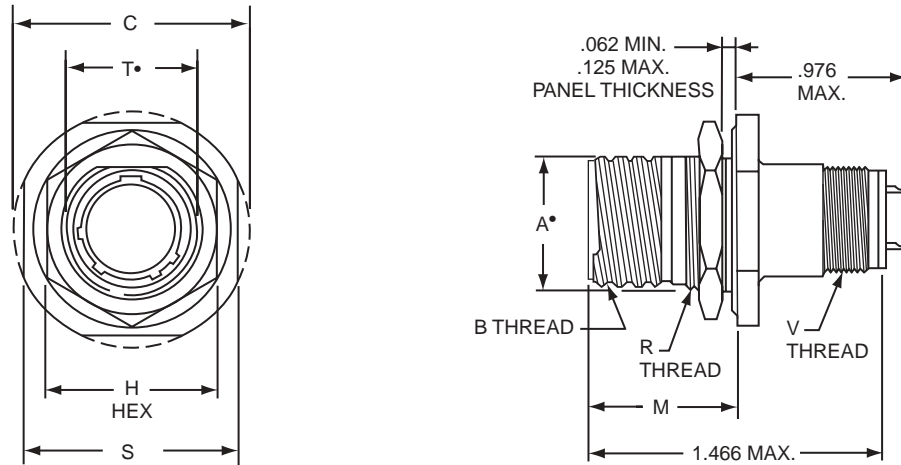

21-52X7XX-XXX

- “D” shaped mounting hole dimensions
- For ordering information, see how to order page 72.
- Plug movement required to clear FTV receptacles: .625 min.

Shell Size	A* +.000 -.010	B Thread Class 2A 0.1P-0.3L-TS (Plated)	C Max	H Hex +.017 -.016	M +.011 -.010	R Thread (Plated)	S +.011 -.010	T* +.010 -.000	V Thread Metric (Plated)
9	.669	.6250	1.199	.875	.871	M17X1-6g0.100R	1.062	.697	M12X1-6g0.100R
11	.769	.7500	1.386	1.000	.871	M20X1-6g0.100R	1.250	.822	M15X1-6g0.100R
13	.955	.8750	1.511	1.188	.878	M25X1-6g0.100R	1.375	1.007	M18X1-6g0.100R
15	1.084	1.0000	1.636	1.312	.878	M28X1-6g0.100R	1.500	1.134	M22X1-6g0.100R
17	1.208	1.1875	1.761	1.438	.878	M32X1-6g0.100R	1.625	1.259	M25X1-6g0.100R
19	1.333	1.2500	1.949	1.562	.878	M35X1-6g0.100R	1.812	1.384	M28X1-6g0.100R
21	1.459	1.3750	2.073	1.688	.878	M38X1-6g0.100R	1.938	1.507	M31X1-6g0.100R
23	1.575	1.5000	2.199	1.812	.878	M41X1-6g0.100R	2.062	1.634	M34X1-6g0.100R
25	1.709	1.6250	2.323	2.000	.878	M44X1-6g0.100R	2.188	1.759	M37X1-6g0.100R

All dimensions for reference only.

jam nut receptacle (UTS crimp)

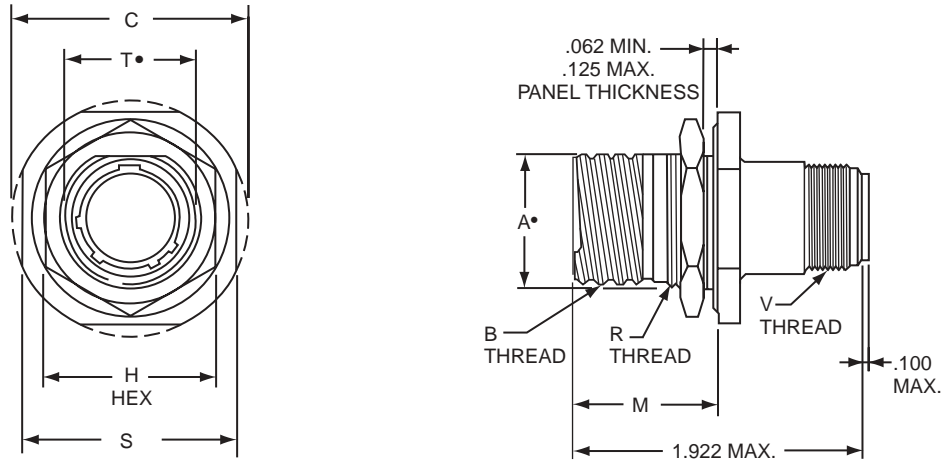

**21-50X7XX-XXX
UTS (Crimp) Contact
MIL-C-39029**

- “D” shaped mounting hole dimensions
- For ordering information, see how to order page 72.
Plug movement required to clear FTV receptacles: .625 min.

Shell Size	A* +.000 -.010	B Thread Class 2A 0.1P-0.3L-TS (Plated)	C Max	H Hex +.017 -.016	M ±.005	R Thread (Plated)	S +.011 -.010	T* +.010 -.000	V Thread Metric (Plated)
9	.669	.6250	1.199	.875	.871	M17X1-6g0.100R	1.062	.697	M15X1-6g0.100R
11	.769	.7500	1.386	1.000	.871	M20X1-6g0.100R	1.250	.822	M18X1-6g0.100R
13	.955	.8750	1.511	1.188	.878	M25X1-6g0.100R	1.375	1.007	M22X1-6g0.100R
15	1.084	1.0000	1.636	1.312	.878	M28X1-6g0.100R	1.500	1.134	M25X1-6g0.100R
17	1.208	1.1875	1.761	1.438	.878	M32X1-6g0.100R	1.625	1.259	M28X1-6g0.100R
19	1.333	1.2500	1.949	1.562	.878	M35X1-6g0.100R	1.812	1.384	M31X1-6g0.100R
21	1.459	1.3750	2.073	1.688	.878	M38X1-6g0.100R	1.938	1.507	M34X1-6g0.100R
23	1.575	1.5000	2.199	1.812	.878	M41X1-6g0.100R	2.062	1.634	M37X1-6g0.100R
25	1.709	1.6250	2.323	2.000	.878	M44X1-6g0.100R	2.188	1.759	M41X1-6g0.100R

All dimensions for reference only.

box mount receptacle (printed circuit board mount)

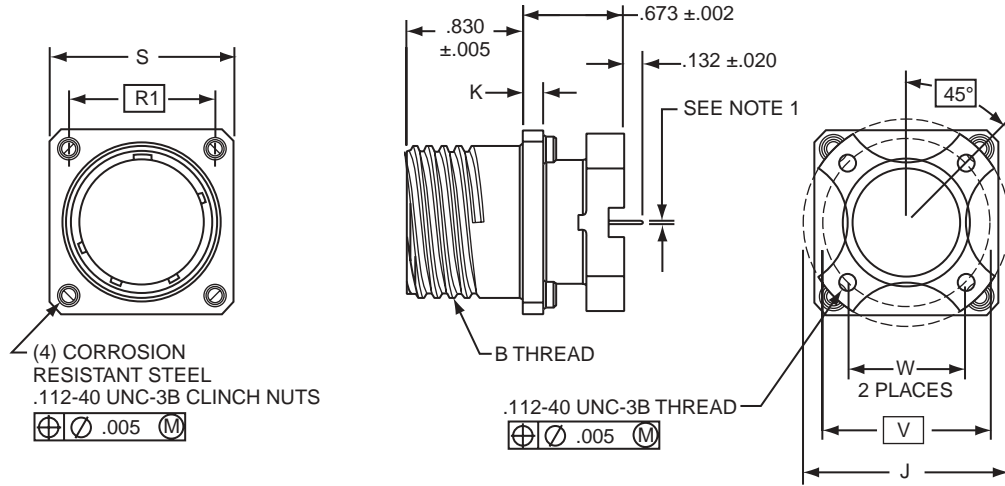

21-80X2XX-XXX

- Standard tail for size 22 is $.020 \pm .001$.
Standard tail for size 20 is $.030 \pm .001$.
For ordering information, see how to order page 72.

Shell Size	B Thread Class 2A 0.1P-0.3L-TS (Plated)	J Dia. $\pm .005$	K $\pm .005$	R ¹ TP	S $\pm .010$	PCB Mounting Dimensions	
						W TP	V Dia. TP
9	.6250	1.016	.085	.719	.938	.532	.752
11	.7500	1.062	.085	.812	1.031	.601	.850
13	.8750	1.250	.085	.906	1.125	.703	.994
15	1.0000	1.375	.085	.969	1.219	.791	1.119
17	1.1875	1.500	.085	1.062	1.312	.875	1.237
19	1.2500	1.625	.085	1.156	1.438	.975	1.379
21	1.3750	1.750	.115	1.250	1.562	1.053	1.489
23	1.5000	1.875	.115	1.375	1.688	1.145	1.619
25	1.6250	2.000	.115	1.500	1.812	1.233	1.744

All dimensions for reference only.

jam nut receptacle (printed circuit board mount)

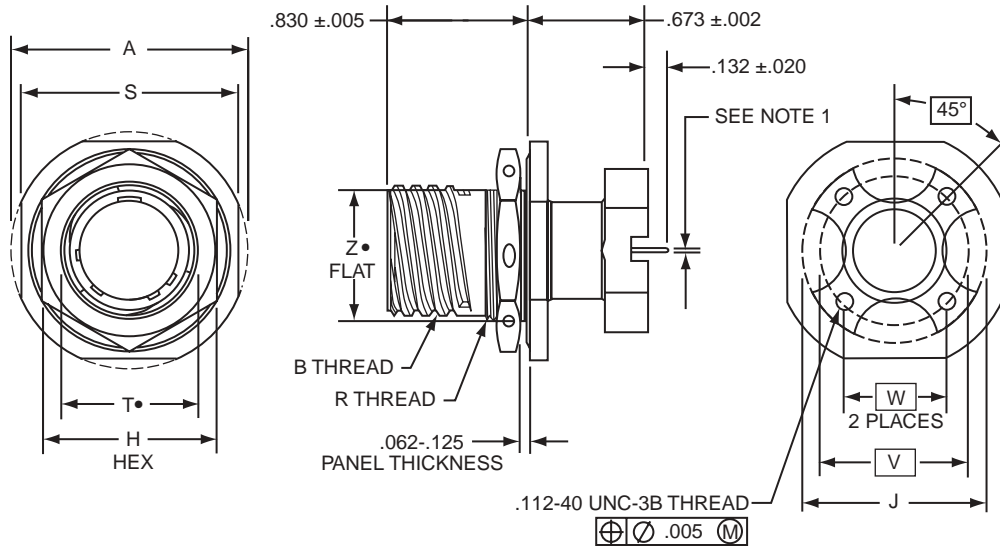

21-80X7XX-XXX

- Standard tail for size 22 is $.020 \pm .001$.
Standard tail for size 20 is $.030 \pm .001$.
- "D" shaped mounting hole dimensions
- For ordering information, see how to order page 72.

Shell Size	A Dia. $\pm .010$	B Thread Class 2A 0.1P-0.3L-TS (Plated)	H Hex $+ .017 - .016$	J Dia. $\pm .005$	R Thread Metric (Plated)	S $\pm .015$	T• Dia. $+ .010 - .000$	PCB Mounting Dimensions		Z• Flat $+ .000 - .010$
								W TP	V Dia. TP	
9	1.188	.6250	.875	1.016	M17X1-6g0.100R	1.062	.697	.532	.752	.669
11	1.375	.7500	1.000	1.062	M20X1-6g0.100R	1.250	.822	.601	.850	.769
13	1.500	.8750	1.188	1.250	M25X1-6g0.100R	1.375	1.007	.703	.994	.955
15	1.625	1.0000	1.312	1.375	M28X1-6g0.100R	1.500	1.134	.791	1.119	1.084
17	1.750	1.1875	1.438	1.500	M32X1-6g0.100R	1.625	1.259	.875	1.237	1.208
19	1.937	1.2500	1.562	1.625	M35X1-6g0.100R	1.812	1.384	.975	1.379	1.333
21	2.062	1.3750	1.688	1.750	M38X1-6g0.100R	1.937	1.507	1.053	1.489	1.459
23	2.188	1.5000	1.812	1.875	M41X1-6g0.100R	2.062	1.634	1.145	1.619	1.575
25	2.312	1.6250	2.000	2.000	M44X1-6g0.100R	2.188	1.759	1.233	1.744	1.709

All dimensions for reference only.

Amphenol® FJT Series Subminiature Cylindrical Filters

The Amphenol® FJT Series space and weight saving design, coupled with a filter, gives high reliability.

- Intermateable with MIL-DTL-38999/27599 Series II connectors (see Catalog 12-090)
- Quick Positive Coupling – 3 point bayonet locking
- Error-proof alternate positioning of shell keyways
- Higher reliability and greater durability with permanently encapsulated contacts
- Environmental Resistant
- Aluminum shells with several finish options

FJT Master Key/Keyway Rotation

Shell Size	AB Angle of Rotation (Degrees)				
	Normal	A	B	C	D
8	100	82	–	–	118
10	100	86	72	128	114
12	100	80	68	132	120
14	100	79	66	134	121
16	100	82	70	130	118
18	100	82	70	130	118
20	100	82	70	130	118
22	100	85	74	126	115
24	100	85	74	126	115

A plug with a given rotation letter will mate with a receptacle with the same rotation letter. The AB angle for a given connector is the same whether it contains pins or sockets. Inserts are not rotated in conjunction with the master key/keyway.

AB angles shown are viewed from the front face of the connector. A receptacle is shown at right. The angles for the plug are exactly the same, except the direction of rotation is opposite of that shown for the receptacle.

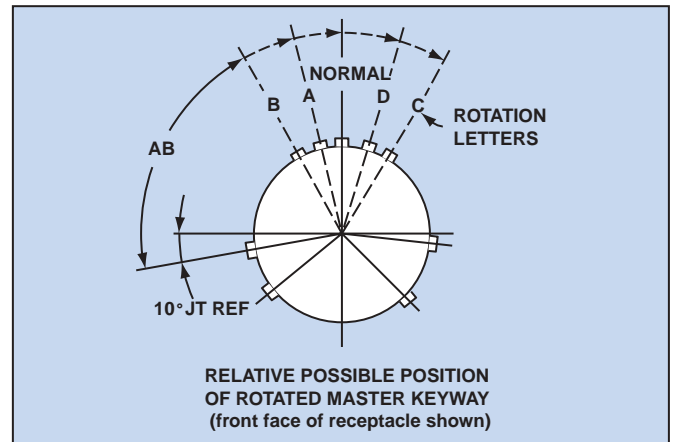

wall mounting receptacle

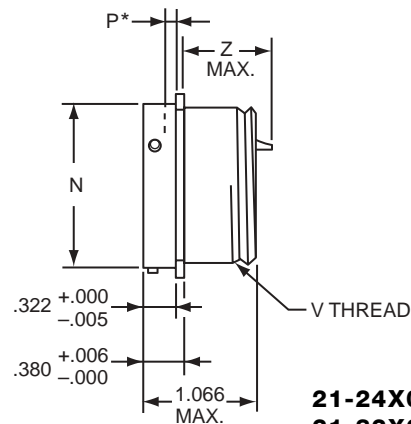
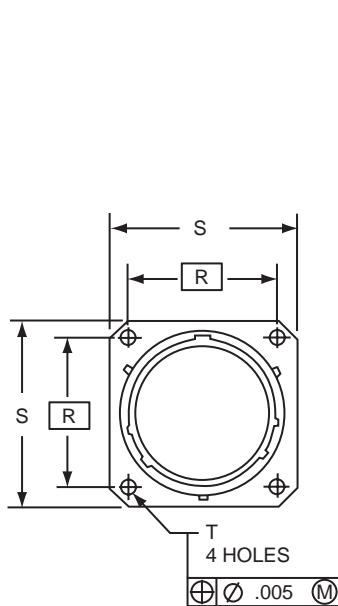

21-24X0XX-XXX (MS27334)
21-32X0XX-XXX (MS27334)

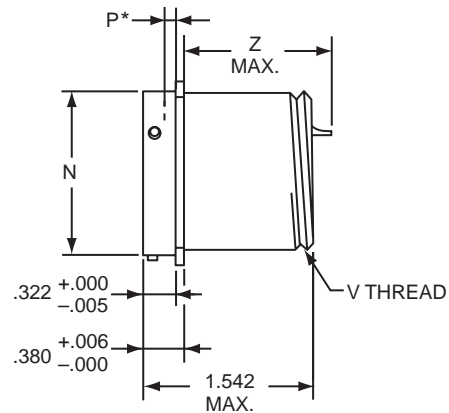

21-37X0XX-XXX (MS27334)

For ordering information, see how to order page 72.

Plug movement required to clear FJT receptacles: .281 min.

* Acceptable panel thickness for back panel mounting a standard receptacle.

Shell Size	N Dia +.001 -.005	P* Max.	R (TP)	S +.011 -.010	T Dia. ±.005	V Thread UNEF-2A (Plated)	SHORT SHELL VHF/UHF/MF Filters			LONG SHELL HF Filters	
							Size 20 Contact Z Max.	Size 16 or 16 & 20 Contacts Z Max.	Size 22 Contact Z Max.	Size 20 Contact Z Max.	Size 16 or 16 & 20 Contacts Z Max.
8	.473	.022	.594	.812	.120	.4375-28	.937	.952	.902	1.300	1.496
10	.590	.027	.719	.938	.120	.5625-24	.937	.952	.902	1.300	1.496
12	.750	.027	.812	1.031	.120	.6875-24	.937	.952	.902	1.300	1.496
14	.875	.027	.906	1.125	.120	.8125-20	.937	.952	.902	1.300	1.496
16	1.000	.027	.969	1.219	.120	.9375-20	.937	.952	.902	1.300	1.496
18	1.125	.027	1.062	1.312	.120	1.0625-18	.937	.952	.902	1.300	1.496
20	1.250	.054	1.156	1.438	.120	1.1875-18	.937	.952	.902	1.300	1.496
22	1.375	.054	1.250	1.562	.120	1.3125-18	.937	.952	.902	1.300	1.496
24	1.500	.054	1.375	1.688	.147	1.4375-18	.937	.952	.902	1.300	1.496

All dimensions for reference only.

wall mounting receptacle (back panel mounting)

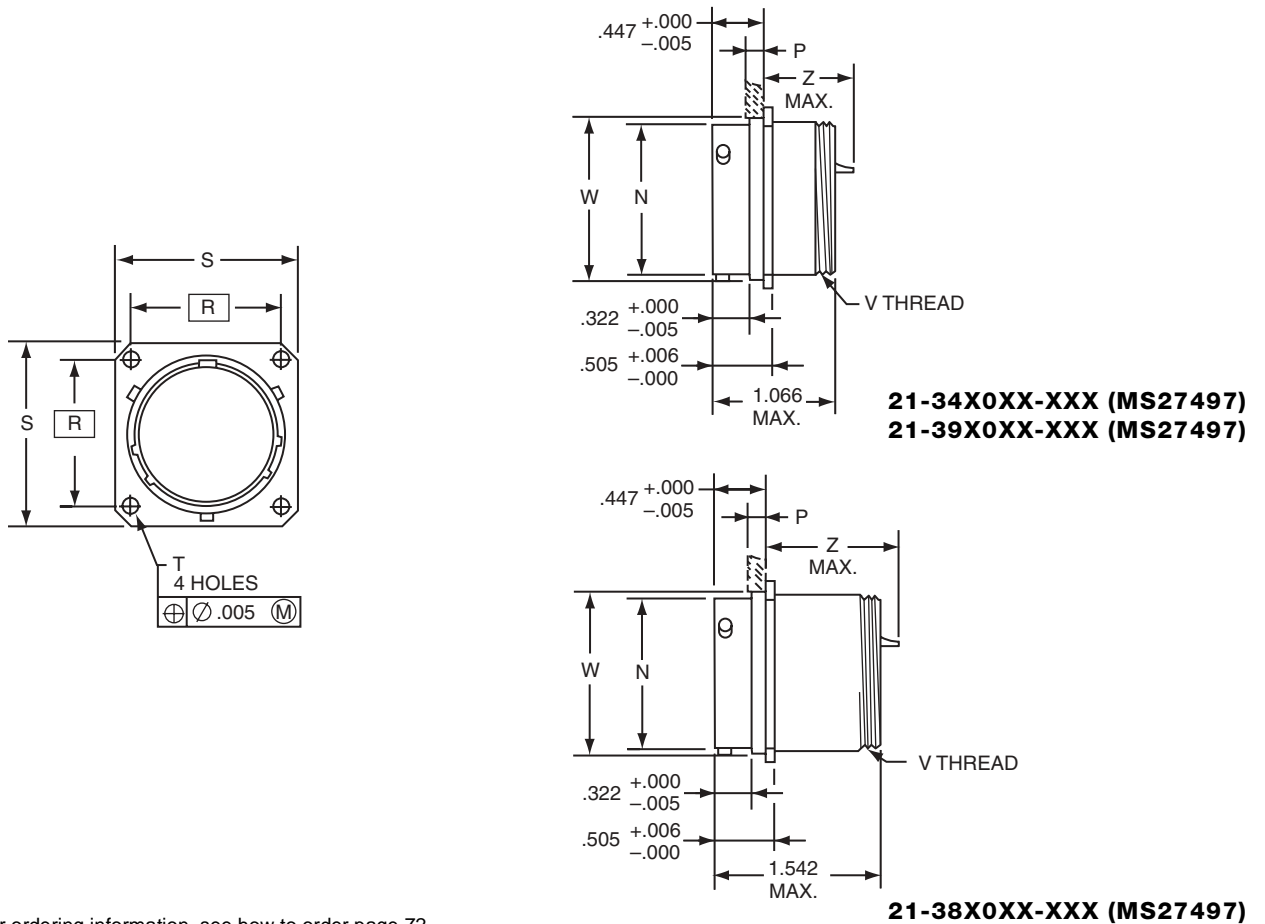

For ordering information, see how to order page 72.
 Plug movement required to clear FJT receptacles: .281 min.

Shell Size	N Dia +.001 -.005	P Max. Panel Thickness	R (TP)	S +.011 -.010	T Dia. ±.005	V Thread UNEF-2A (Plated)	W Dia. +.001 -.005	SHORT SHELL VHF/UHF/MF Filters		LONG SHELL HF Filters	
								Size 16 or 16 & 20 Contacts Z Max.	Size 20 or 22 Contact Z Max.	Size 16 or 16 & 20 Contacts Z Max.	Size 20 Contact Z Max.
8	.473	.147	.594	.812	.120	.4375-28	.516	.900	.875	1.385	1.285
10	.590	.152	.719	.938	.120	.5625-24	.633	.900	.875	1.385	1.285
12	.750	.152	.812	1.031	.120	.6875-24	.802	.900	.875	1.385	1.285
14	.875	.152	.906	1.125	.120	.8125-20	.927	.900	.875	1.385	1.285
16	1.000	.152	.969	1.219	.120	.9375-20	1.052	.900	.875	1.385	1.285
18	1.125	.152	1.062	1.312	.120	1.0625-18	1.177	.900	.875	1.385	1.285
20	1.250	.179	1.156	1.438	.120	1.1875-18	1.302	.900	.875	1.385	1.285
22	1.375	.179	1.250	1.562	.120	1.3125-18	1.427	.900	.875	1.385	1.285
24	1.500	.179	1.375	1.688	.147	1.4375-18	1.552	.900	.875	1.385	1.285

All dimensions for reference only.

box mounting receptacle

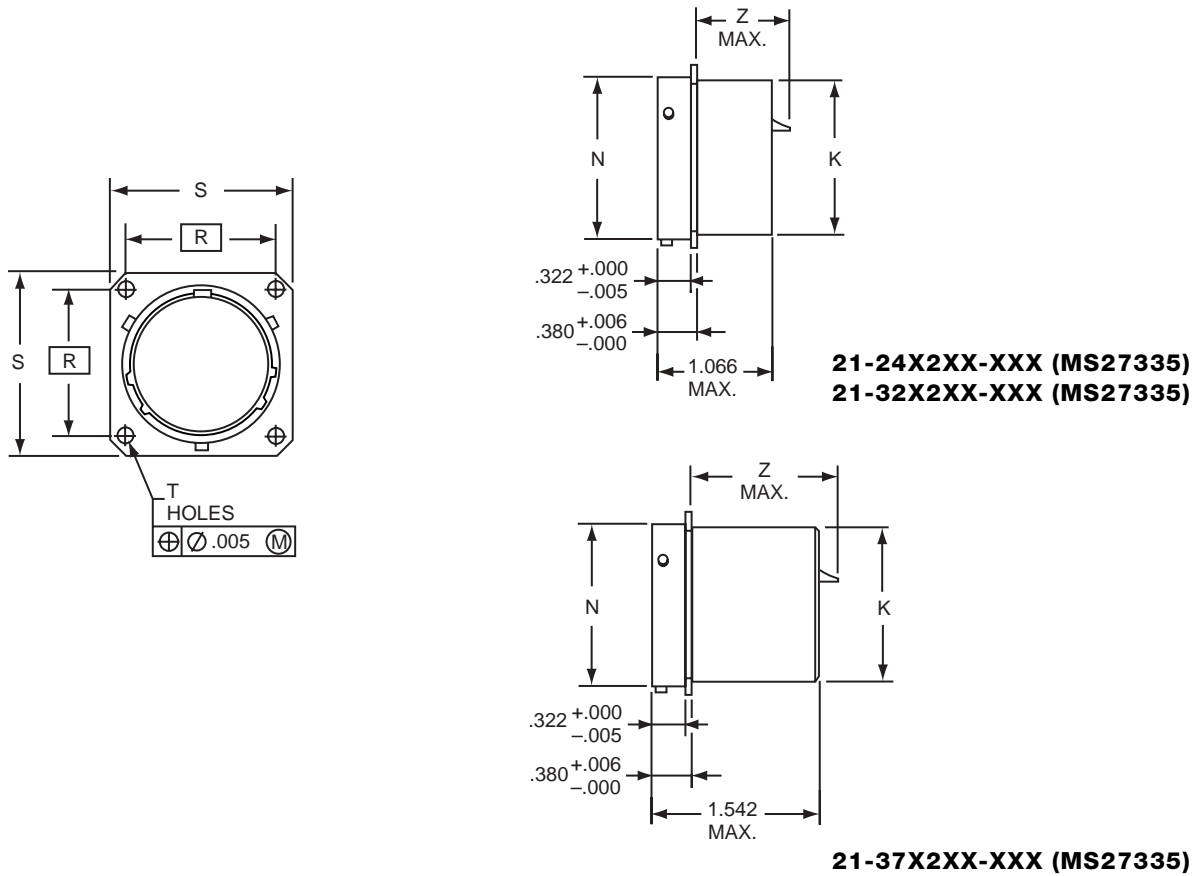

For ordering information, see how to order page 72.

Plug movement required to clear FJT receptacles: .281 min.

Shell Size	K Dia. +.000 / -.007	N Dia +.001 / -.005	R (TP)	S +.011 / -.010	T Dia. ±.005	SHORT SHELL VHF/UHF/MF Filters			LONG SHELL HF Filters	
						Size 20 Contact Z Max.	Size 16 or 16 & 20 Contacts Z Max.	Size 22 Contact Z Max.	Size 20 Contact Z Max.	Size 16 or 16 & 20 Contacts Z Max.
8	.438	.473	.594	.812	.120	.937	.952	.902	1.300	1.496
10	.562	.590	.719	.938	.120	.937	.952	.902	1.300	1.496
12	.688	.750	.812	1.031	.120	.937	.952	.902	1.300	1.496
14	.812	.875	.906	1.125	.120	.937	.952	.902	1.300	1.496
16	.938	1.000	.969	1.219	.120	.937	.952	.902	1.300	1.496
18	1.062	1.125	1.062	1.312	.120	.937	.952	.902	1.300	1.496
20	1.188	1.250	1.156	1.438	.120	.937	.952	.902	1.300	1.496
22	1.312	1.375	1.250	1.562	.120	.937	.952	.902	1.300	1.496
24	1.438	1.500	1.375	1.688	.147	.937	.952	.902	1.300	1.496

All dimensions for reference only.

box mounting receptacle (back panel mounting)

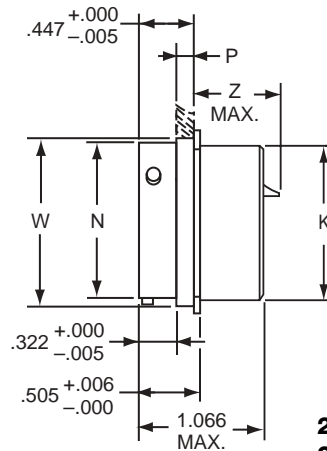
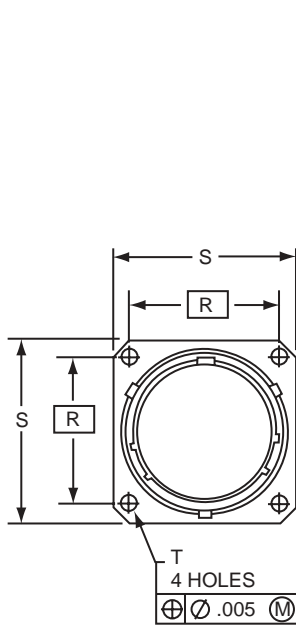

21-34X2XX-XXX (MS27508)
21-39X2XX-XXX (MS27508)

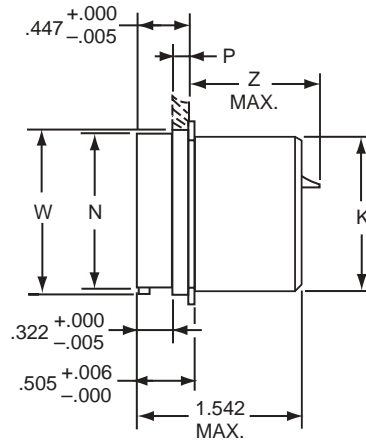

21-38X2XX-XXX (MS27508)

For ordering information, see how to order page 72.

Plug movement required to clear FJT receptacles: .281 min.

Shell Size	K Dia. $^{+.000}_{-.007}$	N Dia. $^{+.001}_{-.005}$	P Max. Panel Thickness	R (TP)	S $^{+.011}_{-.010}$	T Dia. $\pm .005$	W Dia. $^{+.001}_{-.005}$	SHORT SHELL VHF/UHF/MF Filters		LONG SHELL HF Filters	
								Size 16 or 16 & 20 Contacts Z Max.	Size 20 or 22 Contact Z Max.	Size 16 or 16 & 20 Contacts Z Max.	Size 20 Contact Z Max.
8	.438	.473	.147	.594	.812	.120	.516	.900	.875	1.385	1.285
10	.562	.590	.152	.719	.938	.120	.633	.900	.875	1.385	1.285
12	.688	.750	.152	.812	1.031	.120	.802	.900	.875	1.385	1.285
14	.812	.875	.152	.906	1.125	.120	.927	.900	.875	1.385	1.285
16	.938	1.000	.152	.969	1.219	.120	1.052	.900	.875	1.385	1.285
18	1.062	1.125	.152	1.062	1.312	.120	1.177	.900	.875	1.385	1.285
20	1.188	1.250	.179	1.156	1.438	.120	1.302	.900	.875	1.385	1.285
22	1.312	1.375	.179	1.250	1.562	.120	1.427	.900	.875	1.385	1.285
24	1.438	1.500	.179	1.375	1.688	.147	1.552	.900	.875	1.385	1.285

All dimensions for reference only.

jam nut receptacle

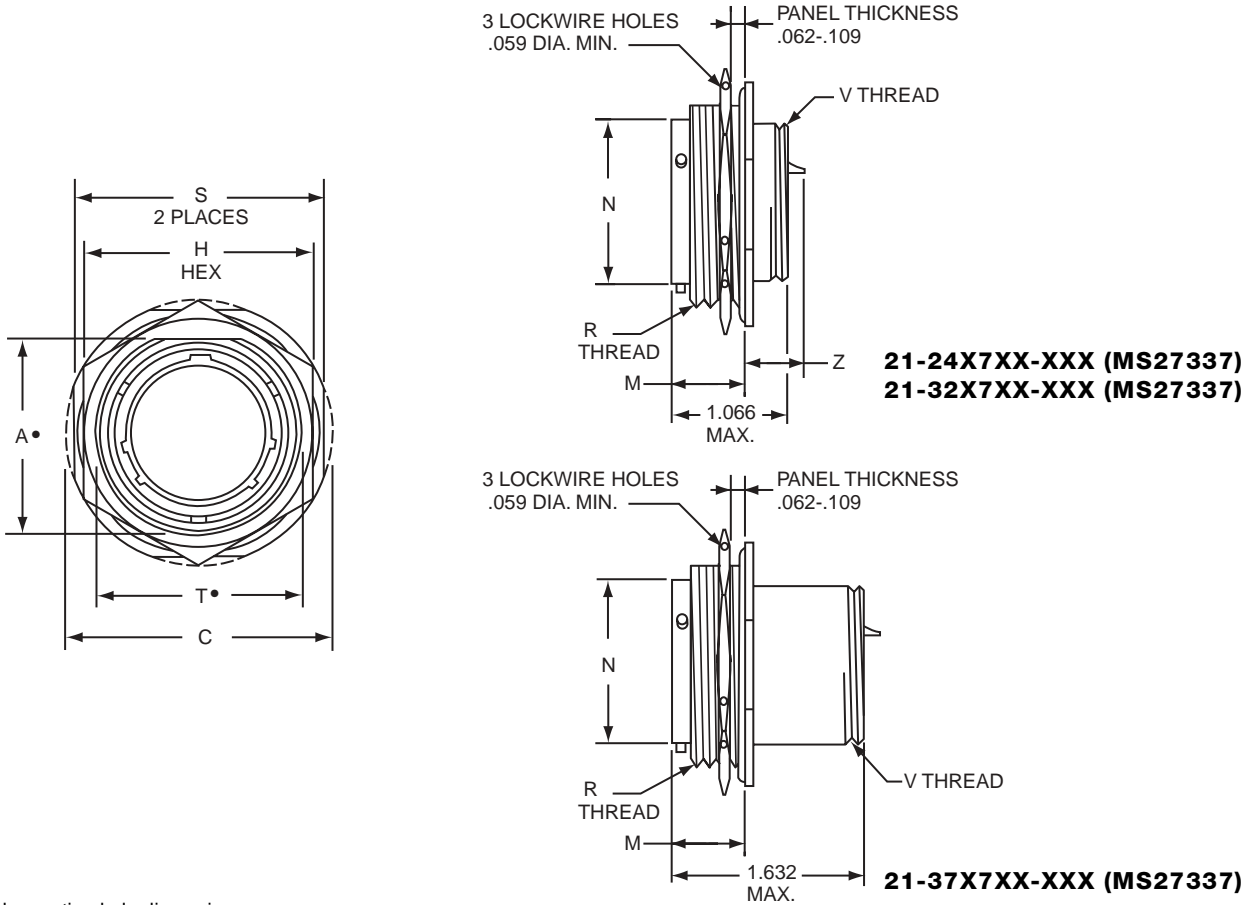

• "D" shaped mounting hole dimensions
 For ordering information, see how to order page 72.
 Plug movement required to clear FJT receptacles: .281 min.

Shell Size	A* Flat +.000 -.010	C Dia. +.011 -.010	H Hex +.017 -.016	M ±.005	N Dia +.001 -.005	R Thread (Plated) Class -2A	S ±.010	T* Dia. +.010 -.000	V Thread UNEF-2A (Plated)	SHORT SHELL VHF/UHF/MF Filters			LONG SHELL HF Filters	
										Size 16 or 16 & 20 Contacts Z Max.	Size 20 Contact Z Max.	Size 22 Contact Z Max.	Size 16 or 16 & 20 Contacts Z Max.	Size 20 Contact Z Max.
8	.830	1.375	1.062	.438	.473	.8750-20UNEF	1.250	.884	.4375-28	.900	.884	.849	1.443	1.276
10	.955	1.500	1.188	.438	.590	1.0000-20UNEF	1.375	1.007	.5625-24	.900	.884	.849	1.443	1.276
12	1.084	1.625	1.312	.438	.750	1.1250-18UNEF	1.500	1.134	.6875-24	.900	.884	.849	1.443	1.276
14	1.208	1.750	1.438	.438	.875	1.2500-18UNEF	1.625	1.259	.8125-20	.900	.884	.849	1.443	1.276
16	1.333	1.938	1.562	.438	1.000	1.3750-18UNEF	1.781	1.384	.9375-20	.900	.884	.849	1.443	1.276
18	1.459	2.016	1.688	.438	1.125	1.5000-18UNEF	1.890	1.507	1.0625-18	.900	.884	.849	1.443	1.276
20	1.576	2.141	1.812	.464	1.250	1.6250-18UNEF	2.016	1.634	1.1875-18	.874	.858	.823	1.443	1.276
22	1.701	2.265	2.000	.464	1.375	1.7500-18UNS	2.140	1.759	1.3125-18	.874	.858	.823	1.417	1.250
24	1.826	2.390	2.125	.464	1.500	1.8750-16UN	2.265	1.884	1.4375-18	.874	.858	.823	1.417	1.250

All dimensions for reference only.

jam nut receptacle (minimum penetration)

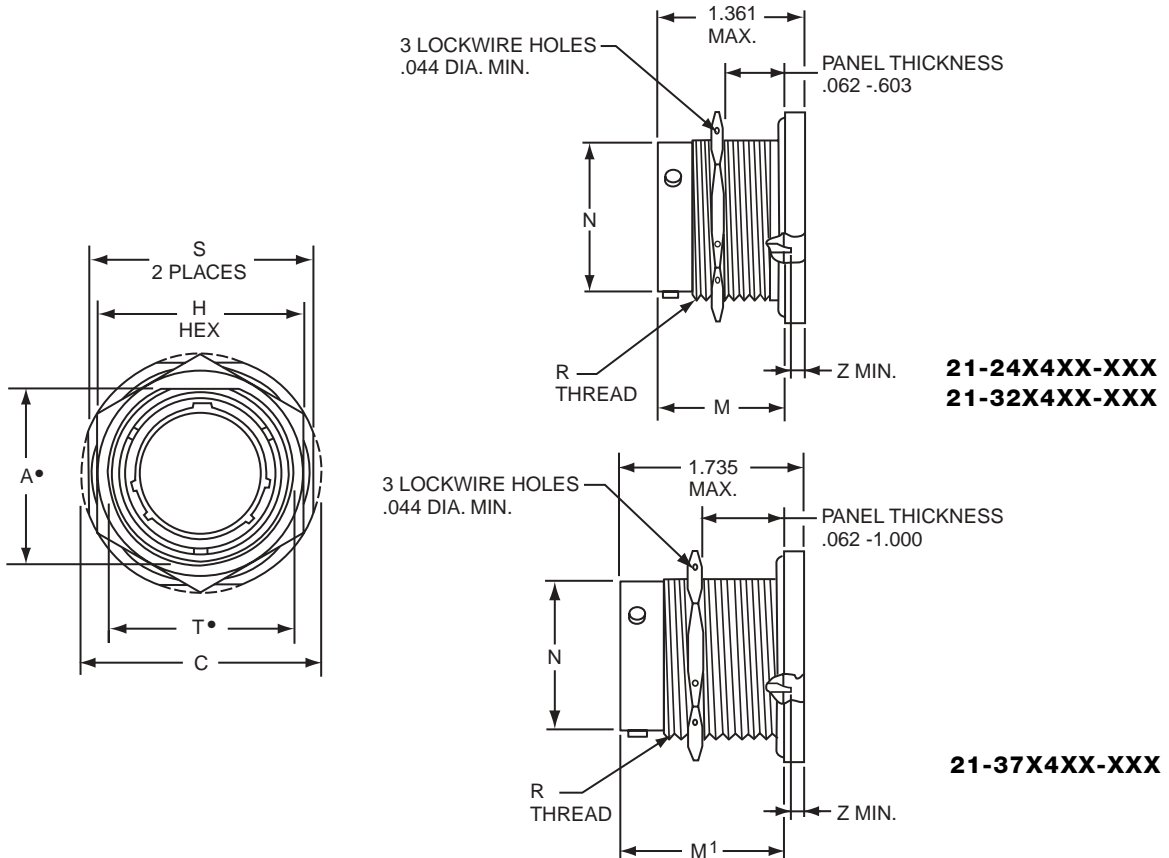

- "D" shaped mounting hole dimensions
- For ordering information, see how to order page 72.
 Plug movement required to clear FJT receptacles: .281 min.

Shell Size	A* Flat +.000 -.010	C Dia. +.011 -.010	H Hex +.017 -.016	M ±.005	M1 ±.005	N Dia +.001 -.005	R Thread UNEF-2A (Plated)	S +.011 -.010	T* Dia. +.010 -.000	SHORT SHELL VHF/UHF/MF Filters			LONG SHELL HF Filters	
										Size 16 or 16 & 20 Contacts Z Max.	Size 20 Contact Z Max.	Size 22 Contact Z Max.	Size 16 or 16 & 20 Contacts Z Max.	Size 20 Contact Z Max.
8	.542	1.062	.750	1.220	1.594	.473	.5625-24	.938	.572	.000	.022	.057	.000	.000
10	.669	1.188	.875	1.220	1.594	.590	.6875-24	1.062	.697	.000	.022	.057	.000	.000
12	.830	1.375	1.062	1.220	1.594	.750	.8750-20	1.250	.844	.000	.022	.057	.000	.000
14	.955	1.500	1.188	1.220	1.594	.875	1.0000-20	1.375	1.007	.000	.022	.057	.000	.000
16	1.084	1.625	1.312	1.220	1.594	1.000	1.1250-18	1.500	1.134	.000	.022	.057	.000	.000
18	1.208	1.750	1.438	1.220	1.594	1.125	1.2500-18	1.625	1.259	.000	.022	.057	.000	.000
20	1.333	1.938	1.562	1.188	1.563	1.250	1.3750-18	1.812	1.384	.000	.022	.057	.000	.000
22	1.459	2.062	1.688	1.188	1.563	1.375	1.5000-18	1.938	1.507	.000	.022	.057	.000	.000
24	1.575	2.188	1.812	1.188	1.563	1.500	1.6250-18	2.062	1.634	.000	.022	.057	.000	.000

All dimensions for reference only.

Amphenol® FLJT Series Subminiature Cylindrical Filters

The Amphenol® FLJT Series offers all the design features of the FJT plus a 100% “scoop-proof” contact protection design.

- Intermountable with MIL-DTL-38999/27599 Series I connectors (see Catalog 12-090)
- Contact Protection - shell design prevents contact damage
- Quick Positive Coupling – 3 point bayonet locking
- Higher reliability and greater durability with permanently encapsulated contacts
- Environmental Resistant
- Aluminum shells with several finish options
- Error-proof alternate positioning of shell keyways
- Corrosion Resistant - 500 hour salt spray olive drab cadmium over nickel plating, class T (aluminum), or stainless steel shells



FLJT Master Key/Keyway Rotation

Shell Size	AB Angle of Rotation (Degrees)				
	Normal	A	B	C	D
9	95	77	–	–	113
11	95	81	67	123	109
13	95	75	63	127	115
15	95	74	61	129	116
17	95	77	65	125	113
19	95	77	65	125	113
21	95	77	65	125	113
23	95	80	69	121	110
25	95	80	69	121	110

A plug with a given rotation letter will mate with a receptacle with the same rotation letter. The AB angle for a given connector is the same whether it contains pins or sockets. Inserts are not rotated in conjunction with the master key/keyway.

AB angles shown are viewed from the front face of the connector. A receptacle is shown at right. The angles for the plug are exactly the same, except the direction of rotation is opposite of that shown for the receptacle.

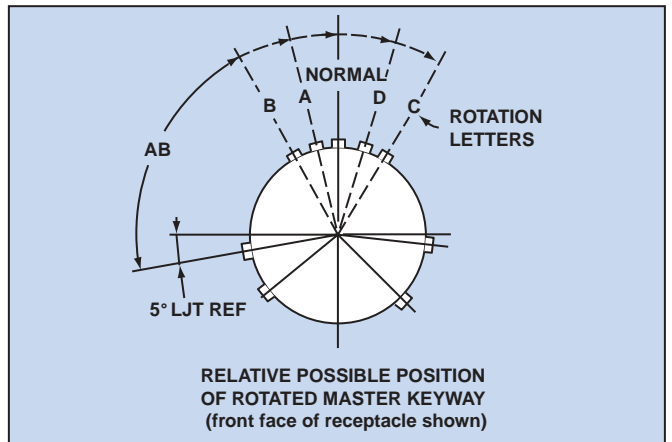

wall mounting receptacle

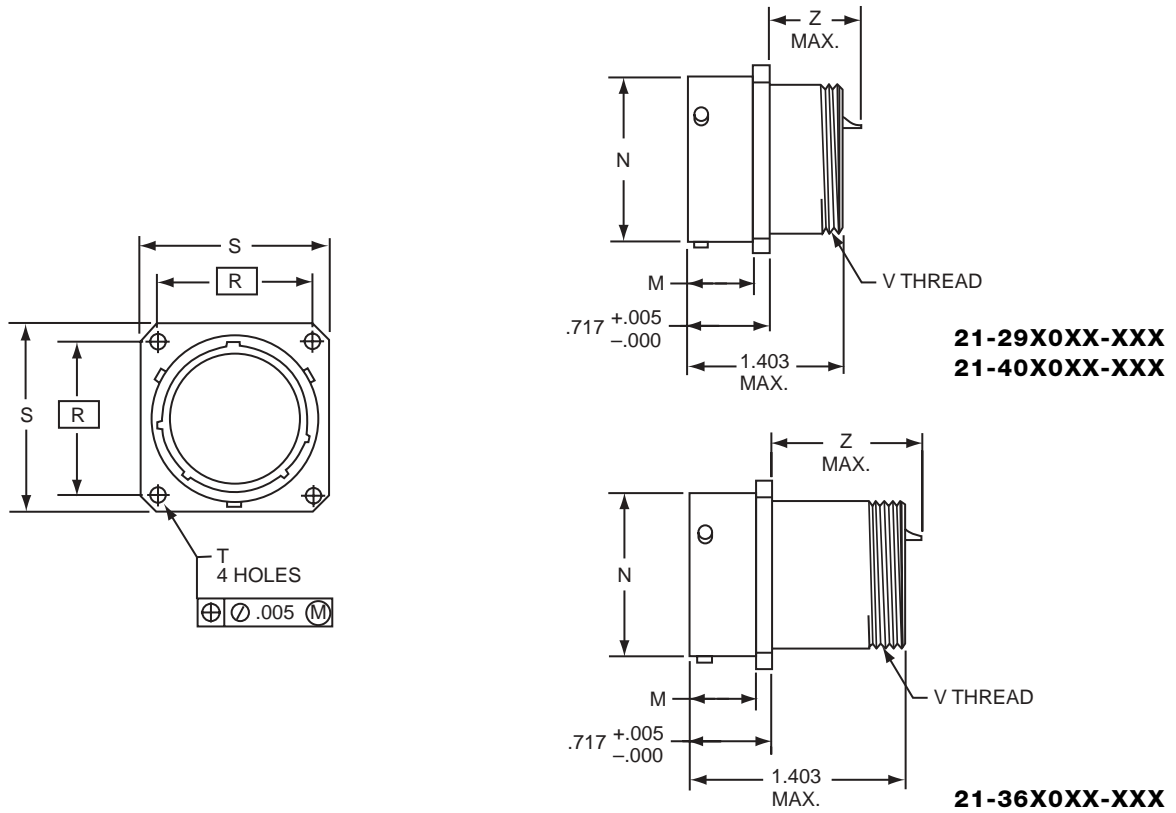

For ordering information, see how to order page 72.
 Plug movement required to clear FLJT receptacles: .625 min.

Shell Size	M +.000 -.006	N Dia. +.001 -.005	R (TP)	S +.011 -.010	T Dia. ±.005	V Thread UNEF-2A (Plated)	SHORT SHELL VHF/UHF/MF Filters			LONG SHELL HF Filters	
							Size 20 Contact Z Max.	Size 16 or 16 & 20 Contacts Z Max.	Size 22 Contact Z Max.	Size 20 Contact Z Max.	Size 16 or 16 & 20 Contacts Z Max.
9	.632	.572	.719	.938	.128	.4375-28	.865	.950	.820	1.324	1.394
11	.632	.700	.812	1.031	.128	.5625-24	.865	.950	.820	1.324	1.394
13	.632	.850	.906	1.125	.128	.6875-24	.865	.950	.820	1.324	1.394
15	.632	.975	.969	1.219	.128	.8125-20	.865	.950	.820	1.324	1.394
17	.632	1.100	1.062	1.312	.128	.9375-20	.865	.950	.820	1.324	1.394
19	.632	1.207	1.156	1.438	.128	1.0625-18	.865	.950	.820	1.324	1.394
21	.602	1.332	1.250	1.562	.128	1.1875-18	.865	.950	.820	1.324	1.394
23	.602	1.457	1.375	1.688	.147	1.3125-18	.865	.950	.820	1.324	1.394
25	.602	1.582	1.500	1.812	.147	1.4375-18	.865	.950	.820	1.324	1.394

All dimensions for reference only.

FLJTPQ

wall mounting receptacle (back panel mounting, UTS crimp)

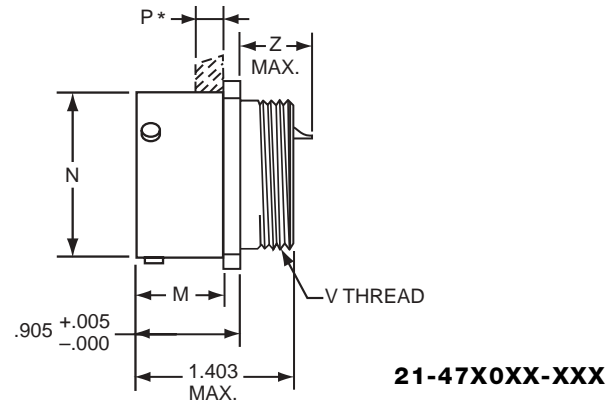
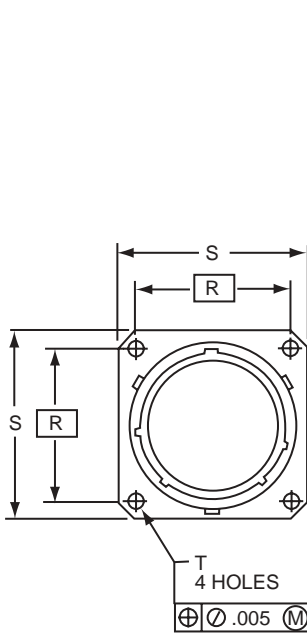

21-47X0XX-XXX

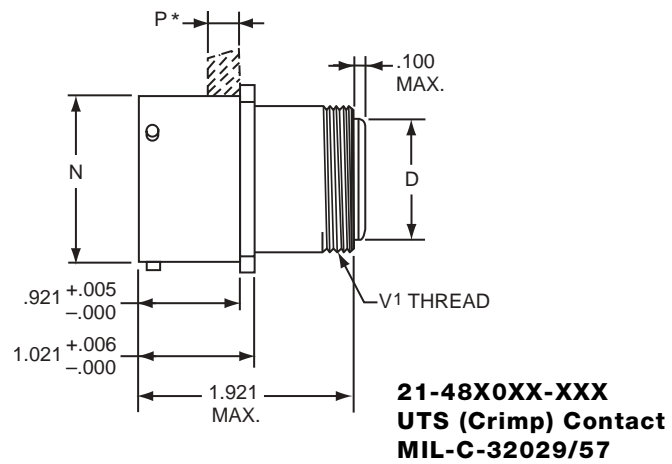

21-48X0XX-XXX
UTS (Crimp) Contact
MIL-C-32029/57

For ordering information, see how to order page 72.

Plug movement required to clear FLJT receptacles: .625 min.

* Acceptable panel thickness for back panel mounting a standard receptacle.

Shell Size	D Dia. $\pm .005$	M $\begin{smallmatrix} +.000 \\ -.006 \end{smallmatrix}$	N Dia. $\begin{smallmatrix} +.001 \\ -.005 \end{smallmatrix}$	P Max. Panel Thickness	R (TP)	S $\begin{smallmatrix} +.011 \\ -.010 \end{smallmatrix}$	T Dia. $\pm .005$	V Thread UNEF-2A (Plated)	V ¹ Thread UNEF-2A (Plated)	SHORT SHELL VHF/UHF Filters		
										Size 20 Contact Z Max.	Size 16 or 16 & 20 Contacts Z Max.	Size 22 Contact Z Max.
9	.299	.820	.572	.234	.719	.938	.128	.4375-28	.5625-24	.672	.763	.632
11	.427	.820	.700	.234	.812	1.031	.128	.625-24	.6875-24	.672	.763	.632
13	.541	.820	.850	.234	.906	1.125	.128	.6875-24	.8125-20	.672	.763	.632
15	.666	.820	.975	.234	.969	1.219	.128	.8125-20	.9375-20	.672	.763	.632
17	.791	.820	1.100	.234	1.062	1.312	.128	.9375-20	1.0625-18	.672	.763	.632
19	.897	.820	1.207	.234	1.156	1.438	.128	1.0625-18	1.1875-18	.672	.763	.632
21	1.022	.790	1.332	.204	1.250	1.562	.128	1.1875-18	1.3125-18	.672	.763	.632
23	1.147	.790	1.457	.204	1.375	1.688	.147	1.3125-18	1.4375-18	.672	.763	.632
25	1.272	.790	1.582	.193	1.500	1.812	.147	1.4375-18	1.5625-18	.672	.763	.632

All dimensions for reference only.

box mounting receptacle

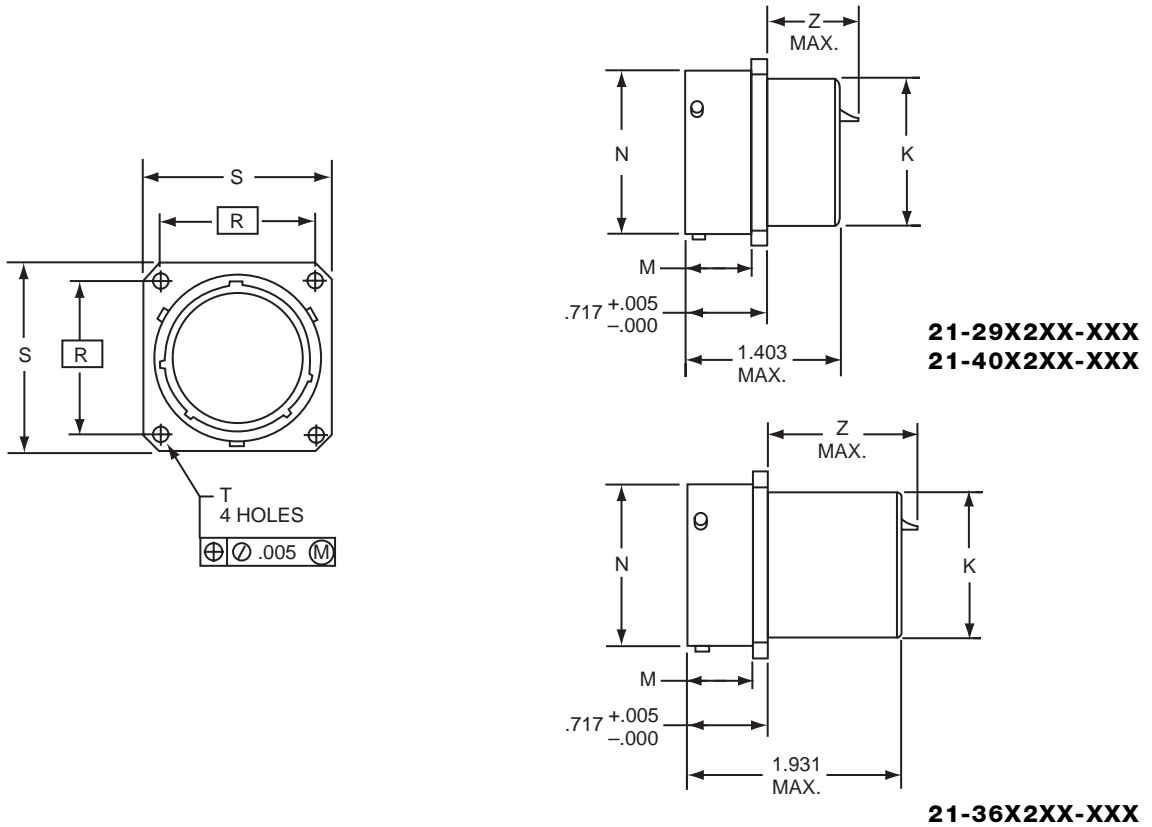

For ordering information, see how to order page 72.

Plug movement required to clear FLJT receptacles: .625 min.

Shell Size	K Dia. +.001 -.006	M +.000 -.006	N Dia. +.001 -.005	R (TP)	S +.011 -.010	T Dia. ±.005	SHORT SHELL VHF/UHF/MF Filters			LONG SHELL HF Filters	
							Size 20 Contact Z Max.	Size 16 or 16 & 20 Contacts Z Max.	Size 22 Contact Z Max.	Size 20 Contact Z Max.	Size 16 or 16 & 20 Contacts Z Max.
9	.436	.632	.572	.719	.938	.128	.865	.950	.820	1.324	1.394
11	.560	.632	.700	.812	1.031	.128	.865	.950	.820	1.324	1.394
13	.686	.632	.850	.906	1.125	.128	.865	.950	.820	1.324	1.394
15	.810	.632	.975	.969	1.219	.128	.865	.950	.820	1.324	1.394
17	.936	.632	1.100	1.062	1.312	.128	.865	.950	.820	1.324	1.394
19	1.060	.632	1.207	1.156	1.438	.128	.865	.950	.820	1.324	1.394
21	1.186	.602	1.332	1.250	1.562	.128	.865	.950	.820	1.324	1.394
23	1.310	.602	1.457	1.375	1.688	.147	.865	.950	.820	1.324	1.394
25	1.436	.602	1.582	1.500	1.812	.147	.865	.950	.820	1.324	1.394

All dimensions for reference only.

FLJTP

box mounting receptacle (back panel mounting, UTS crimp)

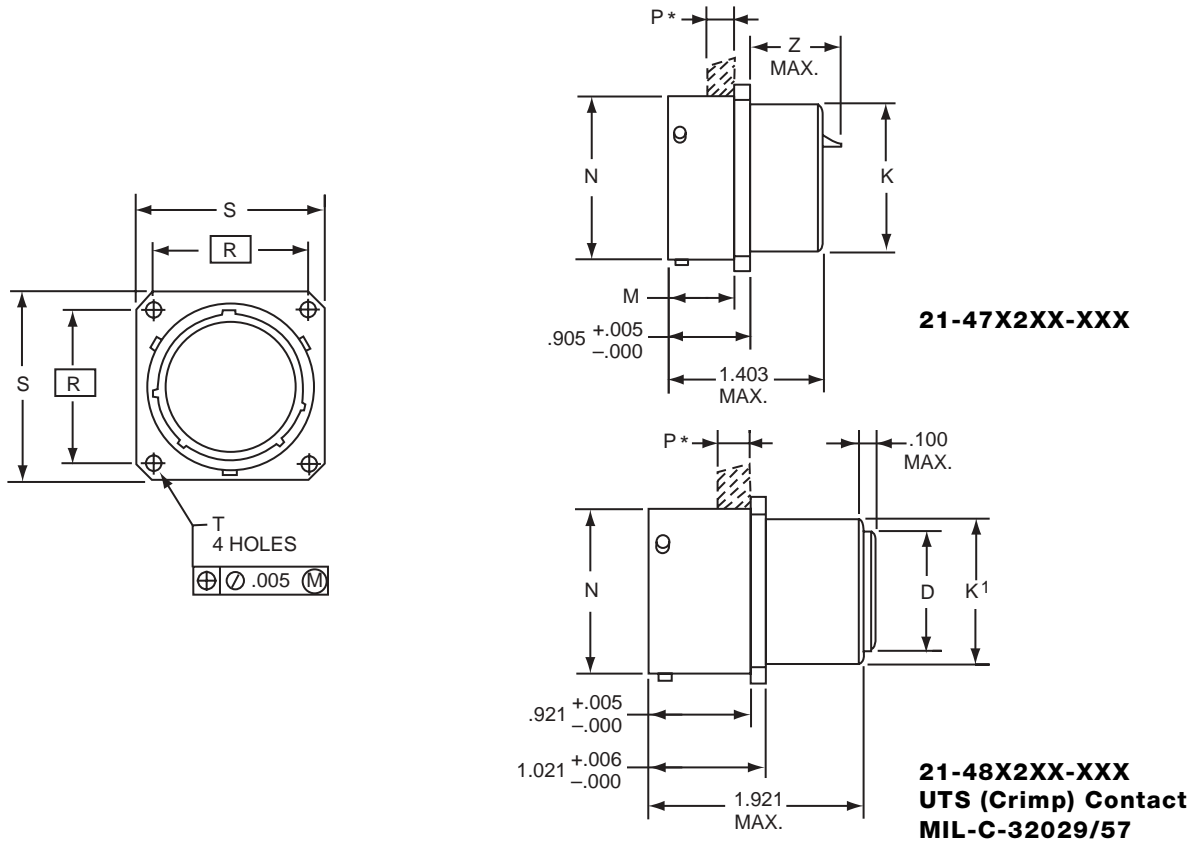

For ordering information, see how to order page 72.

Plug movement required to clear FLJT receptacles: .625 min.

* Acceptable panel thickness for back panel mounting a standard receptacle.

Shell Size	D Dia. ±.005	K Dia. +.000 - .006	K ¹ Dia. +.000 - .007	M +.000 - .006	N Dia. +.001 - .005	P Max. Panel Thickness	R (TP)	S +.011 - .010	T Dia. ±.005	SHORT SHELL VHF/UHF Filters		
										Size 20 Contact Z Max.	Size 16 or 16 & 20 Contacts Z Max.	Size 22 Contact Z Max.
9	.299	.437	.561	.820	.572	.234	.719	.938	.128	.672	.763	.632
11	.427	.562	.687	.820	.700	.234	.812	1.031	.128	.672	.763	.632
13	.541	.688	.811	.820	.850	.234	.906	1.125	.128	.672	.763	.632
15	.666	.812	.937	.820	.975	.234	.969	1.219	.128	.672	.763	.632
17	.791	.938	1.061	.820	1.100	.234	1.062	1.312	.128	.672	.763	.632
19	.897	1.062	1.187	.820	1.207	.234	1.156	1.438	.128	.672	.763	.632
21	1.022	1.188	1.312	.790	1.332	.204	1.250	1.562	.128	.672	.763	.632
23	1.147	1.312	1.437	.790	1.457	.204	1.375	1.688	.147	.672	.763	.632
25	1.272	1.438	1.562	.790	1.582	.193	1.500	1.812	.147	.672	.763	.632

All dimensions for reference only.

FLJT

box mounting receptacle (printed circuit board mount)

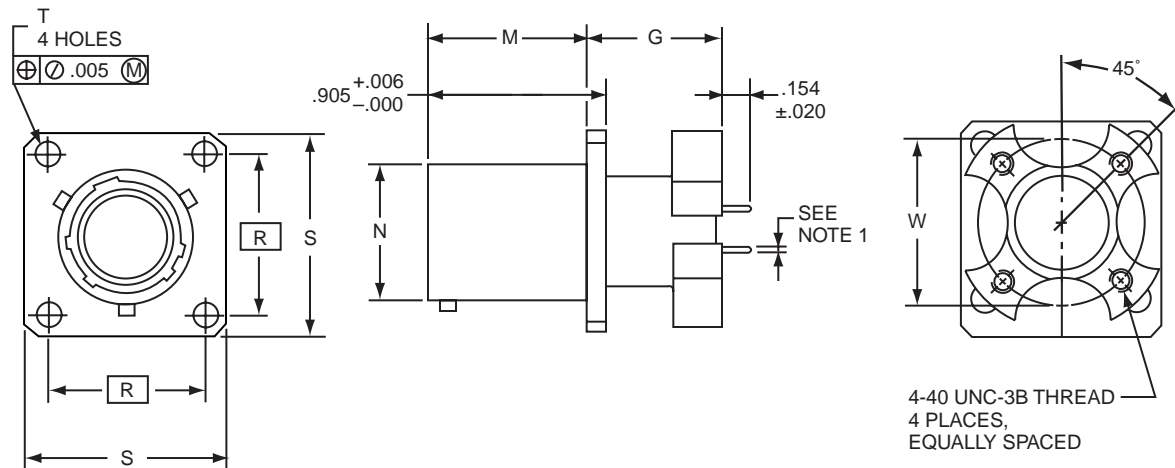

21-57X2XX-XXX

- Standard tail for size 22 is $.020 \pm .001$ dia.
Standard tail for size 22 is $.030 \pm .001$ dia.
- For ordering information, see how to order page 72.
Plug movement required to clear FLJT receptacles: $.625$ min.

Shell Size	G +.006 -.005	M +.000 -.005	N Dia. +.001 -.005	R (TP)	S +.011 -.010	T Dia. +.004 -.003	W
11	.689	.820	.700	.812	1.031	.128	.850
13	.689	.820	.850	.906	1.125	.128	.994
15	.689	.820	.975	.969	1.219	.128	1.119
17	.689	.820	1.100	1.062	1.312	.128	1.237
19	.689	.820	1.207	1.156	1.438	.128	1.379
21	.689	.790	1.332	1.250	1.562	.128	1.489
23	.719	.790	1.457	1.375	1.688	.147	1.619
25	.719	.790	1.582	1.500	1.812	.147	1.744

All dimensions for reference only.

jam nut receptacle

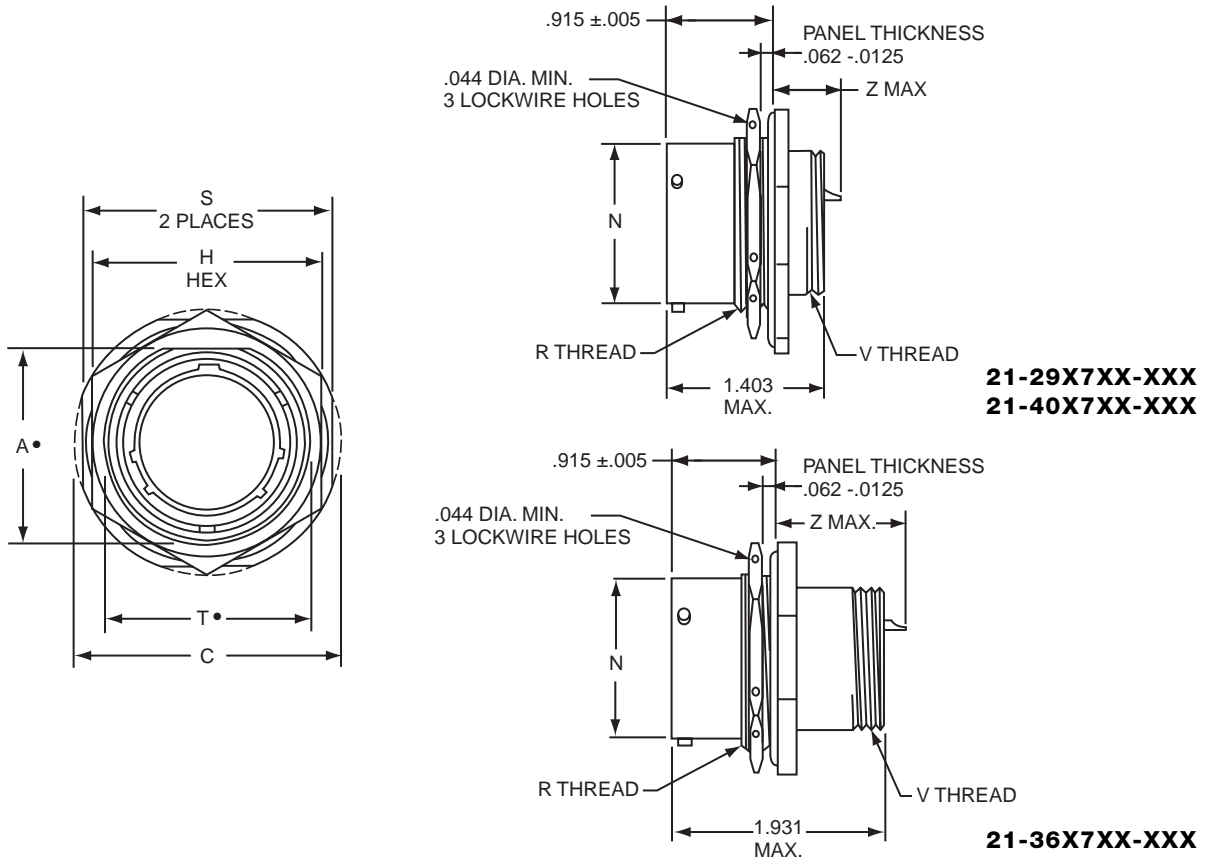

• "D" shaped mounting hole dimensions

For ordering information, see how to order page 72.

Plug movement required to clear FLJT receptacles: .625 min.

Shell Size	A* Flat +.000 -.010	C Dia. +.011 -.010	H Hex +.017 -.016	N Dia +.001 -.005	R Thread (Plated) Class -2A	S +.016 -.015	T* Dia. +.010 -.000	V Thread UNEF-2A (Plated)	SHORT SHELL VHF/UHF/MF Filters			LONG SHELL HF Filters	
									Size 20 Contact Z Max.	Size 16 or 16 & 20 Contacts Z Max.	Size 22 Contact Z Max.	Size 20 Contact Z Max.	Size 16 or 16 & 20 Contacts Z Max.
9	.669	1.188	.875	.572	.6875-24UNEF	1.062	.697	.4375-28	.667	.756	.616	1.228	1.201
11	.769	1.375	1.000	.700	.8125-20UNEF	1.250	.822	.5625-24	.667	.756	.616	1.228	1.201
13	.955	1.500	1.188	.850	1.0000-20UNEF	1.375	1.007	.6875-24	.667	.756	.616	1.228	1.201
15	1.084	1.625	1.312	.975	1.1250-18UNEF	1.500	1.134	.8125-20	.667	.756	.616	1.228	1.201
17	1.208	1.750	1.438	1.100	1.2500-18UNEF	1.625	1.259	.9375-20	.667	.756	.616	1.228	1.201
19	1.333	1.938	1.562	1.207	1.3750-18UNEF	1.812	1.384	1.0625-18	.667	.756	.616	1.228	1.201
21	1.459	2.062	1.688	1.332	1.5000-18UNEF	1.938	1.507	1.1875-18	.667	.756	.616	1.228	1.201
23	1.580	2.188	1.812	1.457	1.6250-18UNEF	2.062	1.634	1.3125-18	.667	.756	.616	1.228	1.201
25	1.709	2.312	2.000	1.582	1.7500-18UNS	2.188	1.759	1.4375-18	.667	.756	.616	1.228	1.201

All dimensions for reference only.

FLJTPQ

jam nut receptacle (UTS crimp)

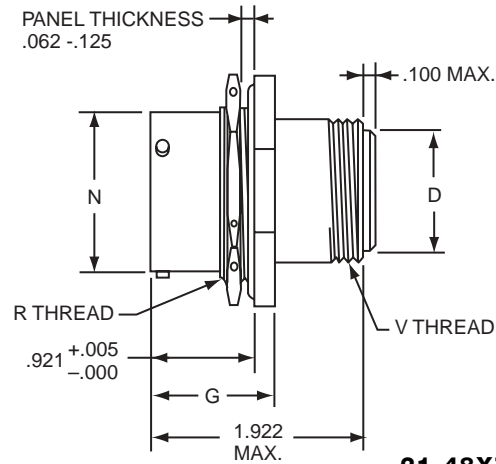
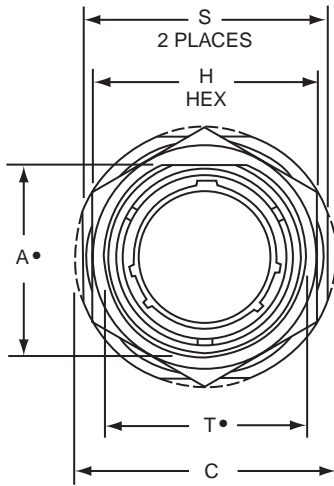

**21-48X7XX-XXX
UTS (Crimp) Contact
MIL-C-39029/57**

• "D" shaped mounting hole dimensions

For ordering information, see how to order page 72.

Plug movement required to clear FLJT receptacles: .625 min.

Shell Size	A* Flat +.000 -.010	C Dia. +.011 -.010	D Dia. ±.005	G +.006 -.005	H Hex +.017 -.016	N Dia +.001 -.005	R Thread (Plated) Class -2A	S +.016 -.015	T* Dia. +.010 -.000	V Thread UNEF-2A (Plated)
9	.669	1.188	.299	1.030	.875	.572	.6875-24UNEF	1.062	.697	.5625-24
11	.769	1.375	.427	1.030	1.000	.700	.8125-20UNEF	1.250	.822	.6875-24
13	.955	1.500	.541	1.030	1.188	.850	1.0000-20UNEF	1.375	1.007	.8125-20
15	1.084	1.625	.666	1.030	1.312	.975	1.1250-18UNEF	1.500	1.134	.9375-20
17	1.208	1.750	.791	1.030	1.438	1.100	1.2500-18UNEF	1.625	1.259	1.0625-18
19	1.333	1.938	.897	1.061	1.562	1.207	1.3750-18UNEF	1.812	1.384	1.1875-18
21	1.459	2.062	1.022	1.061	1.688	1.332	1.5000-18UNEF	1.938	1.507	1.3125-18
23	1.580	2.188	1.147	1.061	1.812	1.457	1.6250-18UNEF	2.062	1.634	1.4375-18
25	1.709	2.312	1.272	1.061	2.000	1.582	1.7500-18UNS	2.188	1.759	1.5625-18

All dimensions for reference only.

FLJT

jam mounting receptacle (printed circuit board mount)

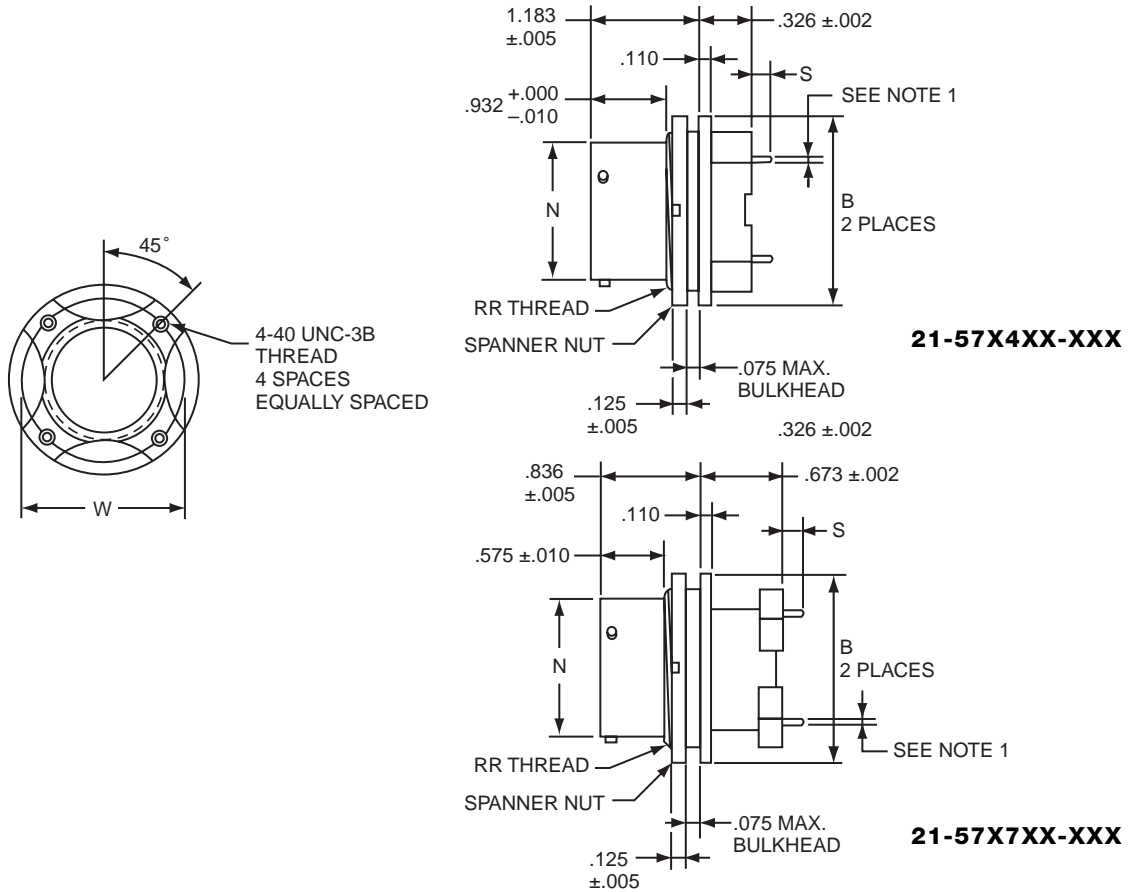

- Standard tail for size 22 is $.020 \pm .001$ dia.
Standard tail for size 22 is $.030 \pm .001$ dia.
- For ordering information, see how to order page 72.
Plug movement required to clear FLJT receptacles: $.625$ min.

Shell Size	B Dia. $\pm .005$	N Dia. $+ .001$ $- .005$	S $\pm .020$	W	RR Thread UNEF-2A
11	1.062	.700	.132	.850	.8125-20
13	1.250	.850	.132	.994	1.0000-20
15	1.375	.975	.132	1.119	1.1250-20
17	1.500	1.100	.132	1.237	1.2500-18
19	1.625	1.207	.132	1.379	1.3750-18
21	1.750	1.332	.132	1.489	1.5000-18
23	1.875	1.457	.132	1.619	1.6250-18
25	2.000	1.582	.132	1.744	1.7500-18

All dimensions for reference only.

jam nut receptacle (minimum penetration)

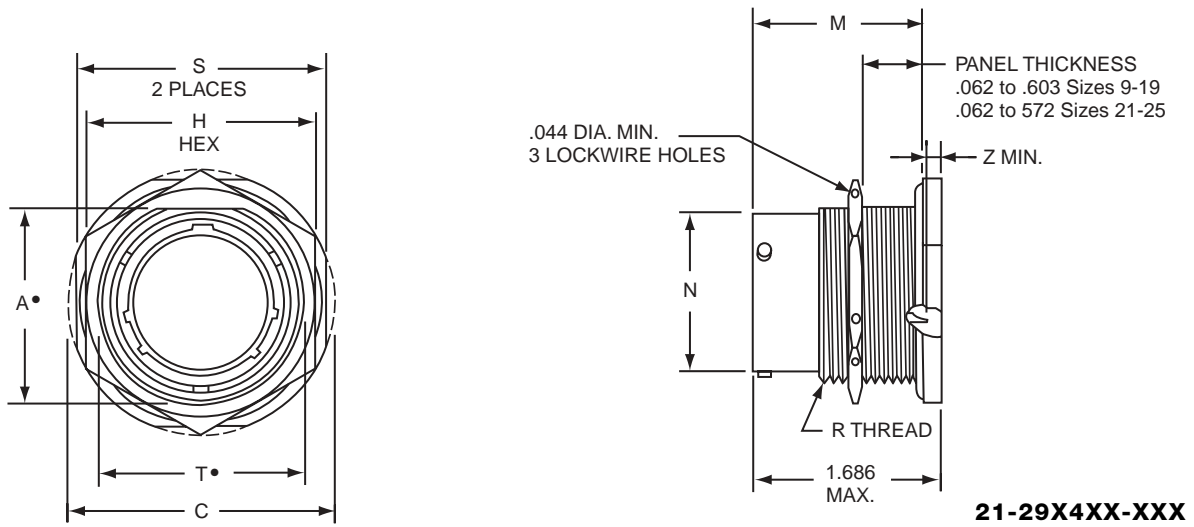

• "D" shaped mounting hole dimensions

For ordering information, see how to order page 72.

Plug movement required to clear FLJT receptacles: .625 min.

Shell Size	A* Flat +0.000 -0.010	C Dia. +0.011 -0.010	H Hex +0.017 -0.016	M ±.005	N Dia +0.001 -0.005	R Thread (Plated) Class -2A	S +0.016 -0.015	T* Dia. +0.010 -0.000	SHORT SHELL VHF/UHF Filters			
									Size 16 Contact Z Max.	Size 16 or 16 & 20 Contacts Z Max.	Size 20 Contact Z Max.	Size 22 Contact Z Max.
9	.669	1.188	.875	1.557	.572	.6875-24UNEF	1.062	.697	.000	.000	.000	.000
11	.769	1.375	1.000	1.557	.700	.8125-20UNEF	1.250	.822	.000	.000	.000	.000
13	.955	1.500	1.188	1.557	.850	1.0000-20UNEF	1.375	1.007	.000	.000	.000	.000
15	1.084	1.625	1.312	1.557	.975	1.1250-18UNEF	1.500	1.134	.000	.000	.000	.000
17	1.208	1.750	1.438	1.557	1.100	1.2500-18UNEF	1.625	1.259	.000	.000	.000	.000
19	1.333	1.938	1.562	1.557	1.207	1.3750-18UNEF	1.812	1.384	.000	.000	.000	.000
21	1.459	2.062	1.688	1.525	1.332	1.5000-18UNEF	1.938	1.507	.000	.000	.000	.000
23	1.580	2.188	1.812	1.525	1.457	1.6250-18UNEF	2.062	1.634	.000	.000	.000	.000
25	1.709	2.312	2.000	1.525	1.582	1.7500-18UNS	2.188	1.759	.000	.000	.000	.000

All dimensions for reference only.

Amphenol® FSJT Series Subminiature Cylindrical Filters

The Amphenol® FSJT Series combines the unique design features of the scoop-proof FLJT Series with the standard mounting dimensions of JT types. (See SJT Catalog 12-091)

- 100% scoop-proof design
- Standard mounting dimensions
- Compliance with European Specifications PAN6433-2, LN29729, BS9522 F0012, VG96912
- Uses proven filter technology with available components from other series
- EMP protection versions available



FSJT Master Key/Keyway Rotation

Shell Size	AB Angle of Rotation (Degrees)				
	Normal	A	B	C	D
8	95	—	—	—	—
10	95	81	67	123	109
12	95	75	63	127	115
14	95	74	61	129	116
16	95	77	65	125	113
18	95	77	65	125	113
20	95	77	65	125	113
22	95	80	69	121	110
24	95	80	69	121	110

A plug with a given rotation letter will mate with a receptacle with the same rotation letter. The AB angle for a given connector is the same whether it contains pins or sockets. Inserts are not rotated in conjunction with the master key/keyway.

AB angles shown are viewed from the front face of the connector. A receptacle is shown at right. The angles for the plug are exactly the same, except the direction of rotation is opposite of that shown for the receptacle.

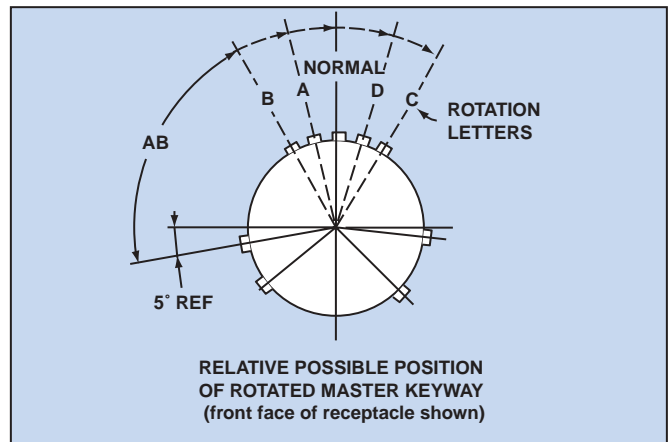

FSJT

wall mounting receptacle

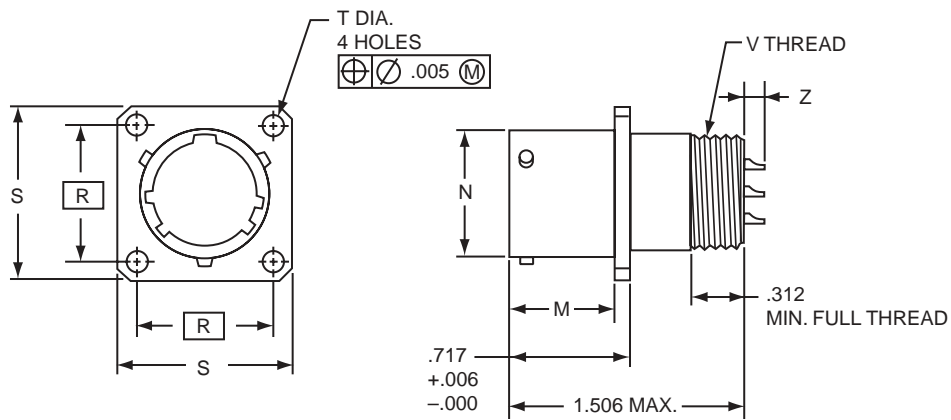

21-63X0XX-XXX

For ordering information, see how to order page 72.

Plug movement required to clear FSJT receptacles: $.625$ min.

Shell Size	M +.000 -.005	N Dia. +.001 -.005	R (TP)	S +.021 -.020	T Dia. +.004 -.003	V Thread UNEF-2A	Z Max.		
							Size 20 Contact	Size 16 or 20 Contacts	Size 22 Contact
10	.632	.590	.719	.938	.120	.5625-24	.165	.265	.134
12	.632	.750	.812	1.031	.120	.6875-24	.165	.265	.134
14	.632	.875	.906	1.125	.120	.8125-20	.165	.265	.134
16	.632	1.000	.969	1.219	.120	.9375-20	.165	.265	.134
18	.632	1.125	1.062	1.312	.120	1.0625-18	.165	.265	.134
20	.602	1.250	1.156	1.438	.120	1.1875-18	.165	.265	.134
22	.602	1.375	1.250	1.562	.120	1.3125-18	.165	.265	.134
24	.602	1.500	1.375	1.688	.147	1.4375-18	.165	.265	.134

All dimensions for reference only.

wall mounting receptacle (UTS crimp)

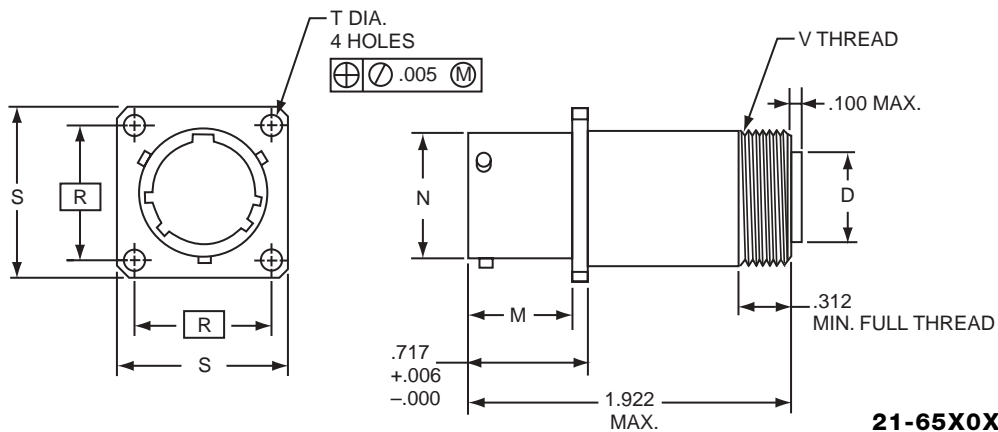

21-65X0XX-XXX
UTS (Crimp) Contact
MIL-C-39029/57

For ordering information, see how to order page 72.
 Plug movement required to clear FSJT receptacles: .625 min.

Shell Size	D Dia. $\pm .005$	M $+ .000 - .005$	N Dia. $+ .001 - .005$	R (TP)	S $+ .021 - .020$	T Dia. $+ .004 - .003$	V Thread UNEF-2A
10	.427	.632	.590	.719	.938	.120	.6875-24
12	.541	.632	.750	.812	1.031	.120	.8125-20
14	.666	.632	.875	.906	1.125	.120	.9375-20
16	.791	.632	1.000	.969	1.219	.120	1.0625-18
18	.897	.632	1.125	1.062	1.312	.120	1.1875-18
20	1.022	.602	1.250	1.156	1.438	.120	1.3125-18
22	1.147	.602	1.375	1.250	1.562	.120	1.4375-18
24	1.272	.602	1.500	1.375	1.688	.147	1.5625-18

All dimensions for reference only.

box mounting receptacle

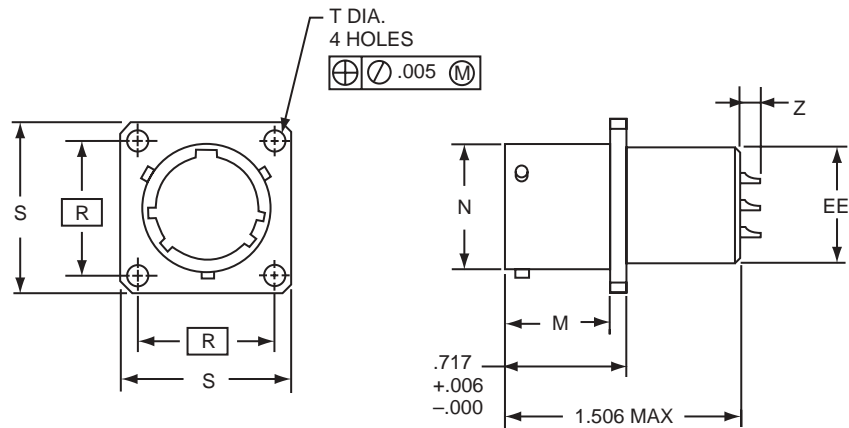

21-63X2XX-XXX

For ordering information, see how to order page 72.

Plug movement required to clear FSJT receptacles: .625 min.

Shell Size	M +.000 -.005	N Dia. +.001 -.005	R (TP)	S +.021 -.020	T Dia. +.004 -.003	EE +.001 -.005	Z Max.			
							Size 16 Contact	Size 20 Contact	Size 16 or 16 & 20 Contacts	Size 22 Contact
10	.632	.590	.719	.938	.120	.562	.265	.165	.265	.134
12	.632	.750	.812	1.031	.120	.687	.265	.165	.265	.134
14	.632	.875	.906	1.125	.120	.812	.265	.165	.265	.134
16	.632	1.000	.969	1.219	.120	.937	.265	.165	.265	.134
18	.632	1.125	1.062	1.312	.120	1.062	.265	.165	.265	.134
20	.602	1.250	1.156	1.438	.120	1.187	.265	.165	.265	.134
22	.602	1.375	1.250	1.562	.120	1.312	.265	.165	.265	.134
24	.602	1.500	1.375	1.688	.147	1.437	.265	.165	.265	.134

All dimensions for reference only.

box mounting receptacle (UTS crimp)

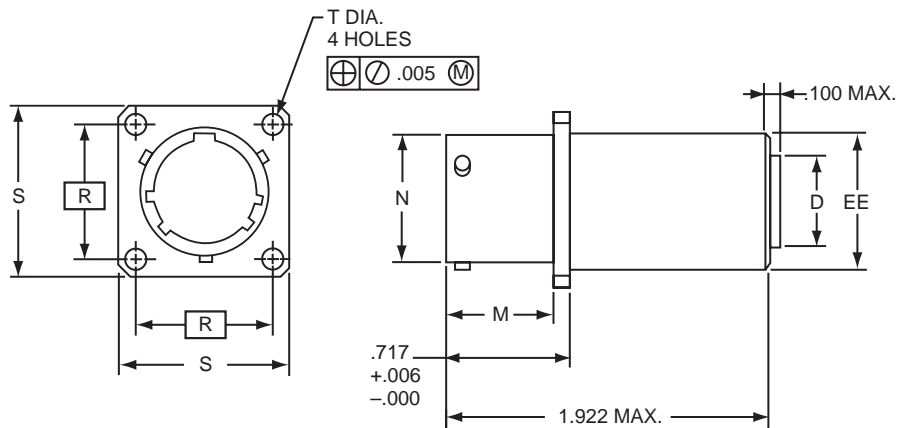

**21-65X2XX-XXX
UTS (Crimp) Contact
MIL-C-39029/57**

For ordering information, see how to order page 72.
Plug movement required to clear FSJT receptacles: .625 min.

Shell Size	D Dia. ±.005	M +.000 - .005	N Dia. +.001 - .005	R (TP)	S +.021 - .020	T Dia. +.004 - .003	EE Dia. +.001 - .005
10	.427	.632	.590	.719	.938	.120	.687
12	.541	.632	.750	.812	1.031	.120	.811
14	.666	.632	.875	.906	1.125	.120	.937
16	.791	.632	1.000	.969	1.219	.120	1.061
18	.897	.632	1.125	1.062	1.312	.120	1.187
20	1.022	.602	1.250	1.156	1.438	.120	1.312
22	1.147	.602	1.375	1.250	1.562	.120	1.437
24	1.272	.602	1.500	1.375	1.688	.147	1.562

All dimensions for reference only.

jam nut receptacle

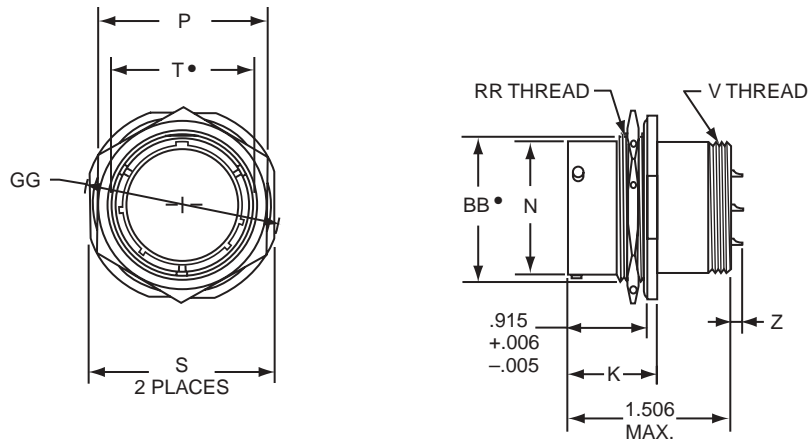

21-63X7XX-XXX

- "D" shaped mounting hole dimensions

For ordering information, see how to order page 72.

Plug movement required to clear FSJT receptacles: .625 min.

Shell Size	K +.006 -.005	N Dia. +.001 -.005	P Hex	S ±.016	T +.010 -.000	V Thread UNEF Class 2A	Z ±.020	BB +.000 -.010	GG Max.	RR Thread UNEF Class 2A	SS +.001 -.016
10	1.024	.590	.875	1.062	.697	.5625-24	.150	.669	1.203	.6875-24	.680
12	1.024	.750	1.062	1.250	.884	.6875-24	.150	.830	1.391	.8750-20	.859
14	1.024	.875	1.188	1.375	1.007	.8125-20	.150	.955	1.515	1.0000-20	.984
16	1.024	1.000	1.312	1.500	1.134	.9375-20	.150	1.084	1.641	1.1250-18	1.108
18	1.055	1.125	1.438	1.625	1.259	1.0625-18	.150	1.208	1.766	1.2500-18	1.233
20	1.055	1.250	1.562	1.812	1.384	1.1875-18	.150	1.333	1.953	1.3750-18	1.358
22	1.055	1.375	1.688	1.938	1.507	1.3125-18	.150	1.459	2.078	1.5000-18	1.483
24	1.055	1.500	1.812	2.062	1.634	1.4375-18	.150	1.580	2.203	1.6250-18	1.610

All dimensions for reference only.

Amphenol® FBL Series IV Subminiature Cylindrical Filters

Components designed to meet the severe mechanical and environmental requirements of MIL-DTL-38999 Series III are now available to Series IV users. Modifications of the connector are available with EMP protection, incorporating MOV's, diodes or a combination of both.

- Intermateable with MIL-DTL-38999 Series IV plugs
- Maintains all the features of standard MIL-DTL-38999 Series IV receptacles
- Scoop-proof pins provide contact protection
- Uses insert patterns from MIL-DTL-38999 Series III



FBL Master Key/Keyway Rotation

Shell Size	Receptacle Key Position				Main Key Receptacle/Basic	
	PP°	QQ°	RR°	SS°	Socket Contact T ₁	Pin Contact T ₂
11	44°28'	151°6'	208°54'	315°32'	.075	.109
13	44°25'	150°31'	209°29'	315°35'	.076	.112
15	44°33'	150°24'	209°36'	315°27'	.096	.132
17	44°36'	150°22'	209°38'	315°24'	.096	.134
19	44°33'	150°27'	209°33'	315°27'	.117	.154
21	44°34'	150°23'	209°37'	315°26'	.118	.155
23	44°34'	150°20'	209°40'	315°26'	.138	.176
25	44°42'	150°22'	209°48'	315°18'	.139	.177

Polarity Dimensions

Key and Keyway Arrangement	XX°	YY°
N	110°	250°
A	100°	260°
B	90°	270°
C	80°	280°
D	70°	290°
K	120°	255°

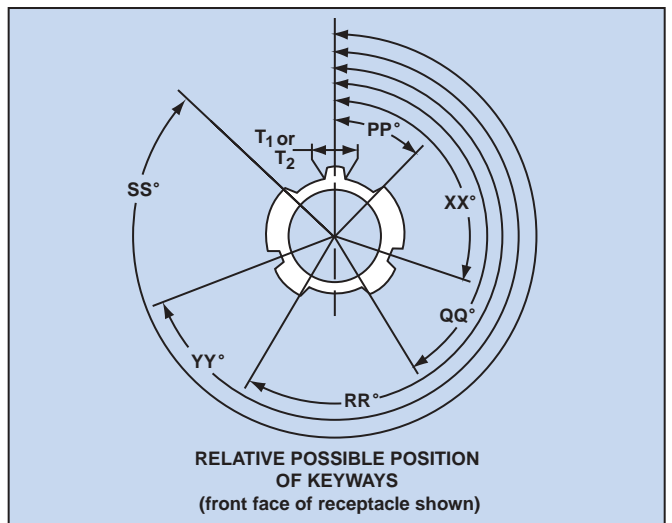

box mounting receptacle wall mounting receptacle

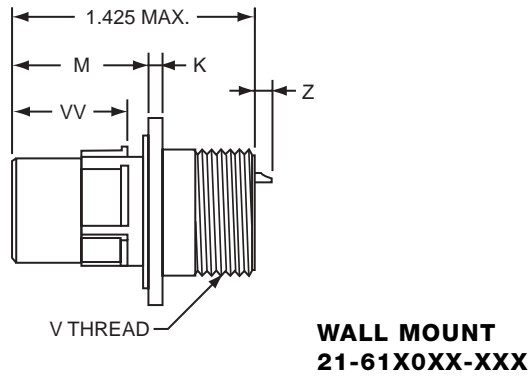
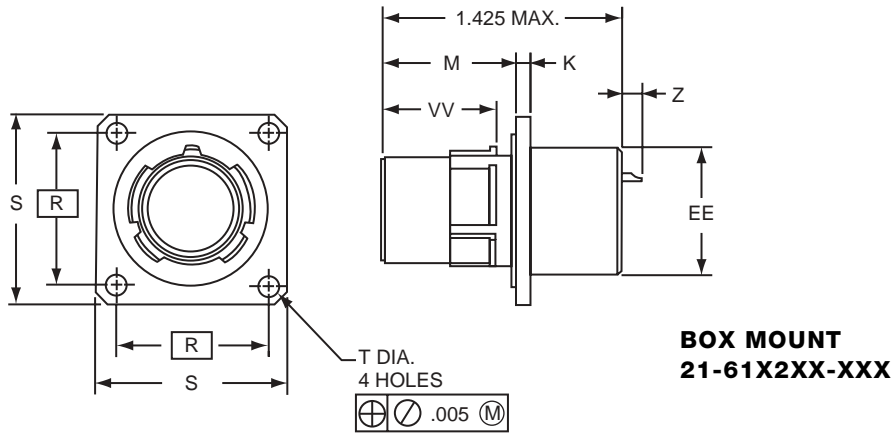

For ordering information, see how to order page 72.

Shell Size	K ±.010	M ±.020	R (TP)	S +.021 -.020	T Dia. +.004 -.003	V Thread (Plated) -.006	EE Dia. +.001 -.005	VV ±.003	Z Max.			
									Size 16 Contact	Size 20 Contact	Size 16 or 16 & 20 Contacts	Size 22 Contact
11	.092	.791	.812	1.029	.128	M15X1-6g0.100R	.589	.672	.265	.165	.265	.134
13	.092	.791	.906	1.124	.128	M18X1-6g0.100R	.707	.672	.265	.165	.265	.134
15	.092	.791	.969	1.218	.128	M22X1-6g0.100R	.865	.672	.265	.165	.265	.134
17	.092	.791	1.062	1.313	.128	M25X1-6g0.100R	.983	.672	.265	.165	.265	.134
19	.092	.791	1.156	1.439	.128	M28X1-6g0.100R	1.101	.662	.265	.165	.265	.134
21	.124	.791	1.250	1.561	.128	M31X1-6g0.100R	1.219	.662	.265	.165	.265	.134
23	.124	.791	1.375	1.687	.147	M34X1-6g0.100R	1.337	.662	.265	.165	.265	.134
25	.124	.791	1.500	1.813	.147	M37X1-6g0.100R	1.455	.662	.265	.165	.265	.134

All dimensions for reference only.

box mounting receptacle (UTS crimp)
 wall mounting receptacle (UTS crimp)

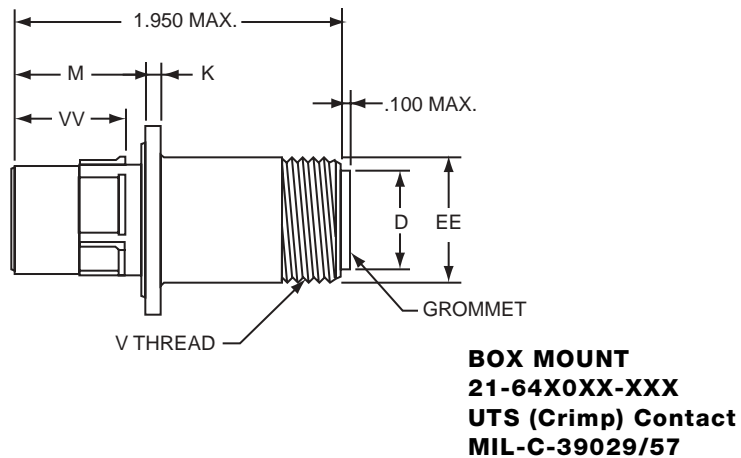
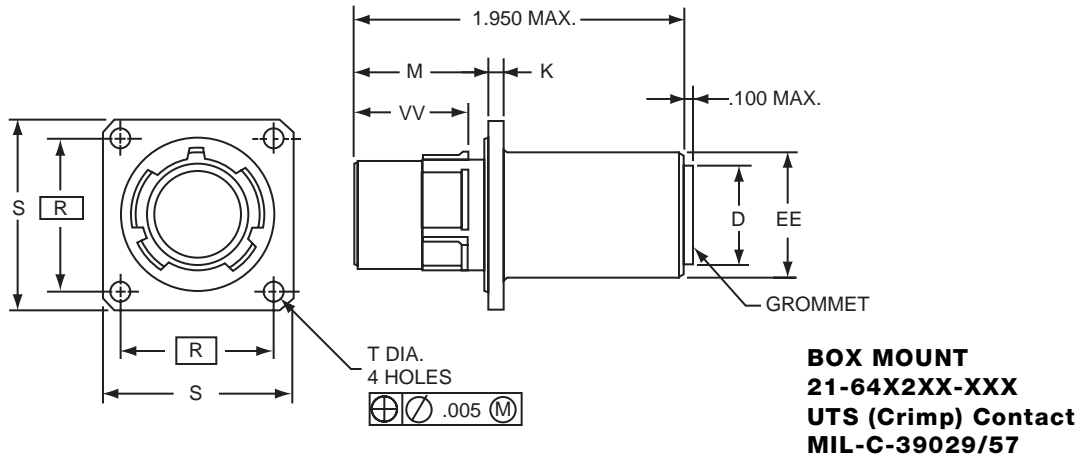

For ordering information, see how to order page 72.

Shell Size	D Dia. ±.005	K ±.010	M ±.020	R (TP)	S +.021 -0.020	T Dia. +.004 -0.003	V Thread (Plated) -.006	EE Dia. +.001 -0.005	VV ±.003
11	.427	.092	.791	.812	1.029	.128	M18X1-6g0.100R	.687	.672
13	.541	.092	.791	.906	1.124	.128	M22X1-6g0.100R	.811	.672
15	.666	.092	.791	.969	1.218	.128	M25X1-6g0.100R	.937	.672
17	.791	.092	.791	1.062	1.313	.128	M28X1-6g0.100R	1.061	.672
19	.897	.092	.791	1.156	1.439	.128	M31X1-6g0.100R	1.187	.662
21	1.022	.124	.791	1.250	1.561	.128	M34X1-6g0.100R	1.312	.662
23	1.147	.124	.791	1.375	1.687	.147	M37X1-6g0.100R	1.437	.662
25	1.272	.124	.791	1.500	1.813	.147	M41X1-6g0.100R	1.562	.662

All dimensions for reference only.

Amphenol® FPT Series Miniature Cylindrical Filters

The Amphenol® FPT Series combines the unique design features of the miniature PT Series with an EMI filter.

- Intermateable with MIL-C-26482 Series connectors (see Catalog 12-070), and MIL-C-83723 Series I connectors (see Catalog MS-102)
- Quick positive coupling with visual confirmation of mating
- Higher reliability and greater durability with permanently encapsulated contacts
- Aluminum shells with several finish options



FPT Alternate Positions

Insert Arrangements	Degrees			
	W	X	Y	Z
10-5	45	151	180	270
10-6	90	–	–	–
10-98	90	180	240	270
12-3	–	–	180	–
12-8	90	112	203	292
12-10	60	155	270	295
12-98	61	135	189	340
14-12	434	90	–	–
14-18	15	90	180	270
14-19	30	165	315	–
16-8	54	152	180	331
16-26	60	–	275	338
18-32	85	138	222	265
20-41	45	126	225	–
22-41	39	–	–	–
22-55	30	142	226	314
24-61	90	180	270	324

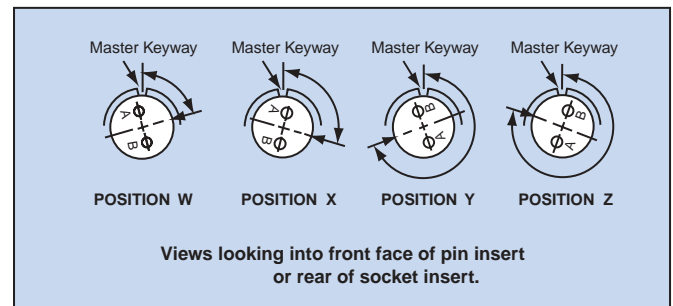

wall mounting receptacle

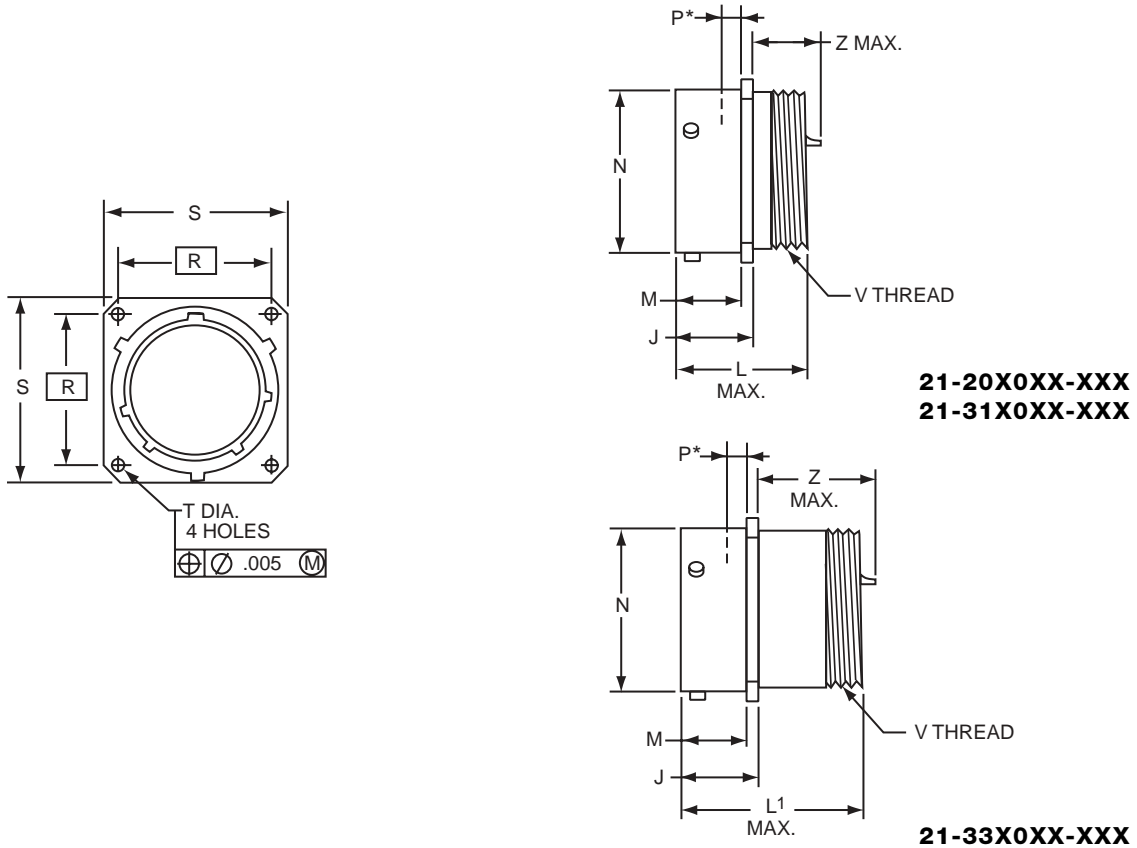

For ordering information, see how to order page 72.

Plug movement required to clear FPT receptacles: .438 min.

* Acceptable panel thickness for back panel mounting a standard receptacle.

Shell Size	J +.021 -.010	M +.010 -.000	N Dia +.001 -.005	P* Max.	R (TP)	S +.011 -.010	T Dia. ±.005	V Thread UNE-F-2A (Plated)	SHORT SHELL VHF/UHF/MF Filters			LONG SHELL HF Filters		
									L Max.	Size 20 Contact Z Max.	Size 16 or 16 & 20 Contacts Z Max.	L ¹ Max.	Size 20 Contact Z Max.	Size 16 or 16 & 20 Contacts Z Max.
8	.493	.431	.473	.087	.594	.812	.120	.4375-28	1.103	.850	.904	1.588	1.258	1.328
10	.493	.431	.590	.087	.719	.938	.120	.5625-24	1.103	.850	.904	1.588	1.258	1.328
12	.493	.431	.750	.087	.812	1.031	.120	.6875-24	1.103	.850	.904	1.588	1.258	1.328
14	.493	.431	.875	.087	.906	1.125	.120	.8125-20	1.103	.850	.904	1.588	1.258	1.328
16	.493	.431	1.000	.087	.969	1.219	.120	.9375-20	1.103	.850	.904	1.588	1.258	1.328
18	.493	.431	1.125	.087	1.062	1.312	.120	1.0625-18	1.103	.850	.904	1.588	1.258	1.328
20	.650	.556	1.250	.212	1.156	1.438	.120	1.1875-18	1.166	.755	.809	1.651	1.163	1.233
22	.650	.556	1.375	.212	1.250	1.562	.120	1.3125-18	1.166	.755	.809	1.651	1.163	1.233
24	.683	.589	1.500	.212	1.375	1.688	.147	1.4375-18	1.166	.722	.776	1.651	1.130	1.200

All dimensions for reference only.

box mounting receptacle

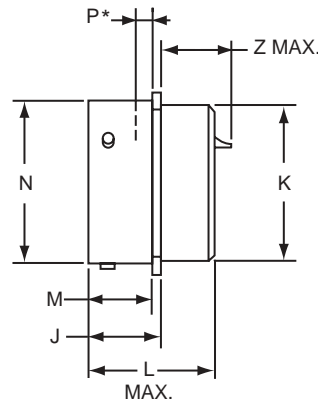
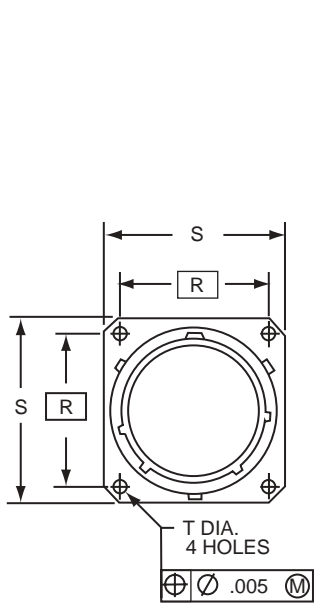

21-20X2XX-XXX
21-31X2XX-XXX

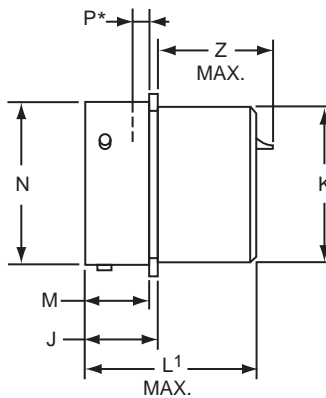

21-33X2XX-XXX

For ordering information, see how to order page 72.

Plug movement required to clear FPT receptacles: .438 min.

* Acceptable panel thickness for back panel mounting a standard receptacle.

Shell Size	J +.021 -.010	K Dia. +.011 -.000	M +.010 -.000	N Dia +.001 -.005	P* Max.	R (TP)	S +.011 -.010	T Dia. ±.005	SHORT SHELL VHF/UHF/MF Filters			LONG SHELL HF Filters		
									L Max.	Size 20 Contact Z Max.	Size 16 or 16 & 20 Contacts Z Max.	L ¹ Max.	Size 20 Contact Z Max.	Size 16 or 16 & 20 Contacts Z Max.
8	.493	.438	.431	.473	.087	.594	.812	.120	1.103	.850	.904	1.588	1.258	1.328
10	.493	.562	.431	.590	.087	.719	.938	.120	1.103	.850	.904	1.588	1.258	1.328
12	.493	.688	.431	.750	.087	.812	1.031	.120	1.103	.850	.904	1.588	1.258	1.328
14	.493	.812	.431	.875	.087	.906	1.125	.120	1.103	.850	.904	1.588	1.258	1.328
16	.493	.938	.431	1.000	.087	.969	1.219	.120	1.103	.850	.904	1.588	1.258	1.328
18	.493	1.062	.431	1.125	.087	1.062	1.312	.120	1.103	.850	.904	1.588	1.258	1.328
20	.650	1.188	.556	1.250	.212	1.156	1.438	.120	1.166	.755	.809	1.651	1.163	1.233
22	.650	1.312	.556	1.375	.212	1.250	1.562	.120	1.166	.755	.809	1.651	1.163	1.233
24	.683	1.438	.589	1.500	.212	1.375	1.688	.147	1.166	.722	.776	1.651	1.130	1.200

All dimensions for reference only.

jam nut receptacle

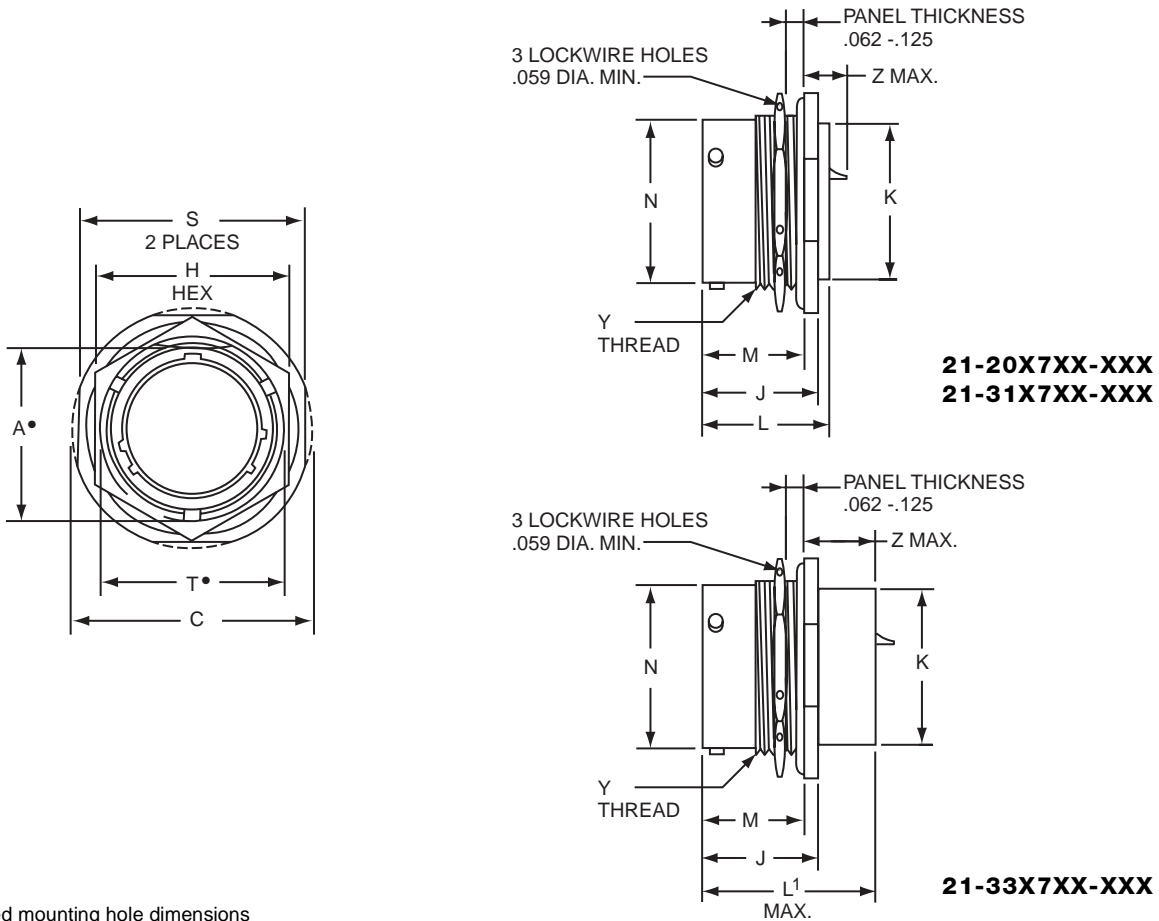

• "D" shaped mounting hole dimensions

For ordering information, see how to order page 72.

Plug movement required to clear FPT receptacles: .438 min.

Shell Size	A* Flat +.000 -.010	C Dia. +.011 -.010	H Hex +.017 -.016	J +.006 -.005	K Dia. +.011 -.000	M ±.005	N Dia +.001 -.005	S ±.010	T* Dia. +.010 -.000	Y Thread UNEF-2A (Plated)	SHORT SHELL VHF/UHF/MF Filters			LONG SHELL HF Filters		
											L Max.	Size 20 Contact Z Max.	Size 16 or 16 & 20 Contacts Z Max.	L ¹ Max.	Size 20 Contact Z Max.	Size 16 or 16 & 20 Contacts Z Max.
8	.542	1.062	.750	.821	.438	.696	.473	.938	.572	.5625-24	1.103	.642	.698	1.588	1.050	1.120
10	.669	1.188	.875	.821	.562	.696	.590	1.062	.697	.6875-24	1.103	.642	.698	1.588	1.050	1.120
12	.830	1.375	1.062	.821	.688	.696	.750	1.250	.884	.8750-20	1.103	.642	.698	1.588	1.050	1.120
14	.955	1.500	1.188	.821	.812	.696	.875	1.375	1.009	1.0000-20	1.103	.642	.698	1.588	1.050	1.120
16	1.084	1.625	1.312	.821	.938	.696	1.000	1.500	1.134	1.1250-18	1.103	.642	.698	1.588	1.050	1.120
18	1.208	1.750	1.438	.821	1.062	.696	1.125	1.625	1.259	1.2500-18	1.103	.642	.698	1.588	1.050	1.120
20	1.333	1.938	1.562	1.040	1.188	.884	1.250	1.812	1.384	1.3750-18	1.166	.516	.570	1.651	.924	.994
22	1.459	2.062	1.688	1.040	1.312	.884	1.375	1.938	1.509	1.5000-18	1.166	.516	.570	1.651	.924	.994
24	1.575	2.188	1.812	1.073	1.438	.917	1.500	2.062	1.634	1.6250-18	1.166	.483	.537	1.651	.891	.961

All dimensions for reference only.

jam nut receptacle (minimum penetration)

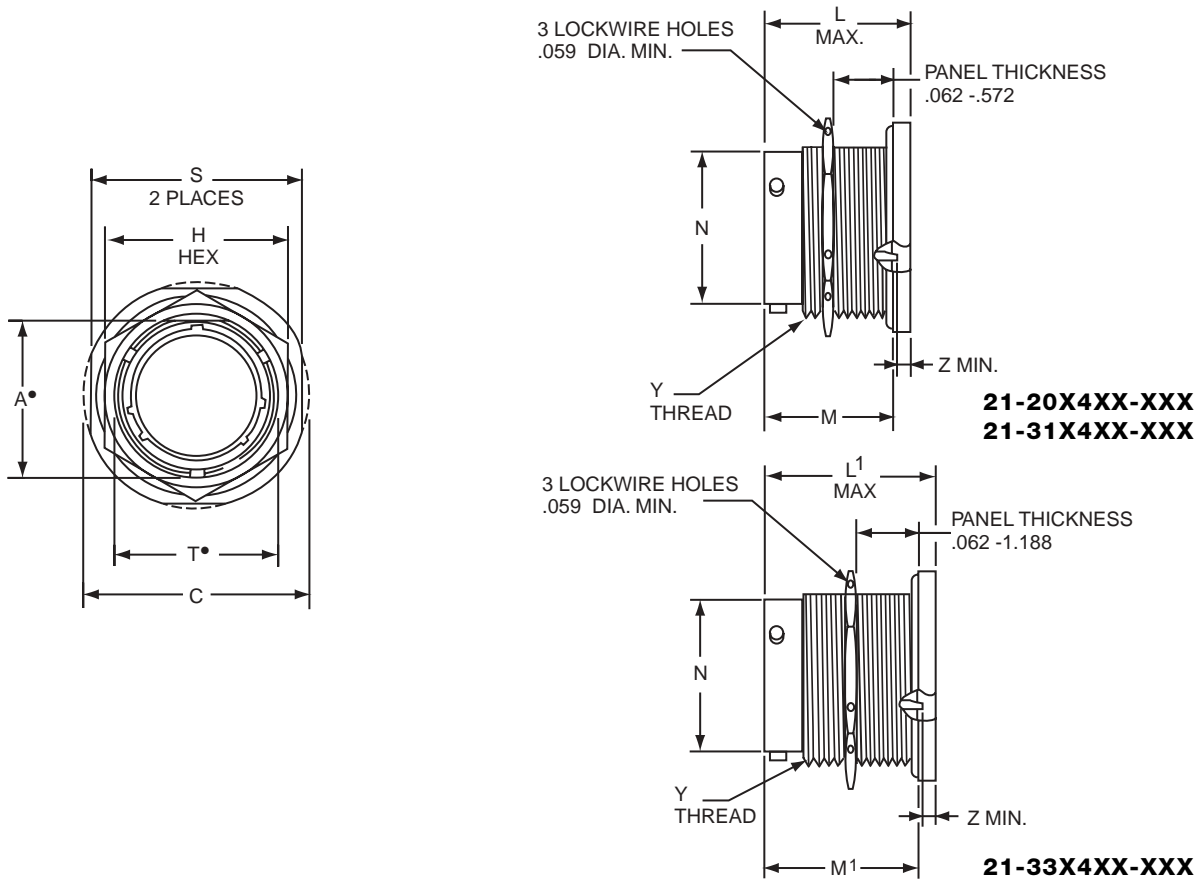

• "D" shaped mounting hole dimensions

For ordering information, see how to order page 72.

Plug movement required to clear FPT receptacles: .438 min.

Shell Size	A* Flat +.000 -.010	C Dia. +.011 -.010	H Hex +.017 -.016	M	M ¹	N Dia +.001 -.005	S	T* Dia. +.010 -.000	Y Thread UNEUF-2A (Plated)	SHORT SHELL VHF/UHF/MF Filters			LONG SHELL HF Filters		
										L Max.	Size 20 Contact Z Max.	Size 16 or 16 & 20 Contacts Z Max.	L ¹ Max.	Size 20 Contact Z Max.	Size 16 or 16 & 20 Contacts Z Max.
8	.542	1.062	.750	1.235	1.690	.473	.938	.572	.5625-24	1.366	.022	.029	1.821	.070	.000
10	.669	1.188	.875	1.235	1.690	.590	1.062	.697	.6875-24	1.366	.022	.029	1.821	.070	.000
12	.830	1.375	1.062	1.235	1.690	.750	1.250	.884	.8750-20	1.366	.022	.029	1.821	.070	.000
14	.955	1.500	1.188	1.235	1.690	.875	1.375	1.009	1.0000-20	1.366	.022	.029	1.821	.070	.000
16	1.084	1.625	1.312	1.235	1.690	1.000	1.500	1.134	1.1250-18	1.366	.022	.029	1.821	.070	.000
18	1.208	1.750	1.438	1.235	1.690	1.125	1.625	1.259	1.2500-18	1.366	.022	.029	1.821	.070	.000
20	1.333	1.938	1.562	1.266	1.721	1.250	1.812	1.384	1.3750-18	1.428	.062	.029	1.883	.070	.000
22	1.459	2.062	1.688	1.266	1.721	1.375	1.938	1.509	1.5000-18	1.428	.062	.029	1.883	.070	.000
24	1.575	2.188	1.812	1.266	1.721	1.500	2.062	1.634	1.6250-18	1.428	.062	.029	1.883	.070	.000

All dimensions for reference only.

wall mounting receptacle

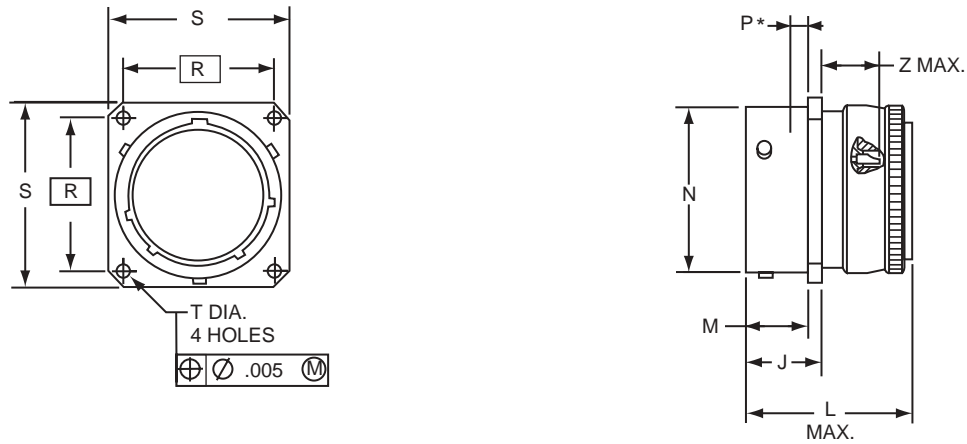

21-22X0XX-XXX

For ordering information, see how to order page 72.

Plug movement required to clear FPT receptacles: .438 min.

* Acceptable panel thickness for back panel mounting a standard receptacle.

Shell Size	J +.021 -.010	M +.010 -.000	N Dia +.001 -.005	P* Max.	R (TP)	S +.011 -.010	T Dia. ±.005	SHORT SHELL VHF/UHF/MF Filters	
								L Max.	Size 20 Contact Z Max.
8	.493	.431	.473	.087	.594	.812	.120	1.409	.774
10	.493	.431	.590	.087	.719	.938	.120	1.409	.774
12	.493	.431	.750	.087	.812	1.031	.120	1.409	.774
14	.493	.431	.875	.087	.906	1.125	.120	1.409	.774
16	.493	.431	1.000	.087	.969	1.219	.120	1.409	.774
18	.493	.431	1.125	.087	1.062	1.312	.120	1.409	.774
20	.650	.556	1.250	.212	1.156	1.438	.120	1.553	.679
22	.650	.556	1.375	.212	1.250	1.562	.120	1.553	.679
24	.683	.589	1.500	.212	1.375	1.688	.147	1.553	.646

All dimensions for reference only.

jam nut receptacle

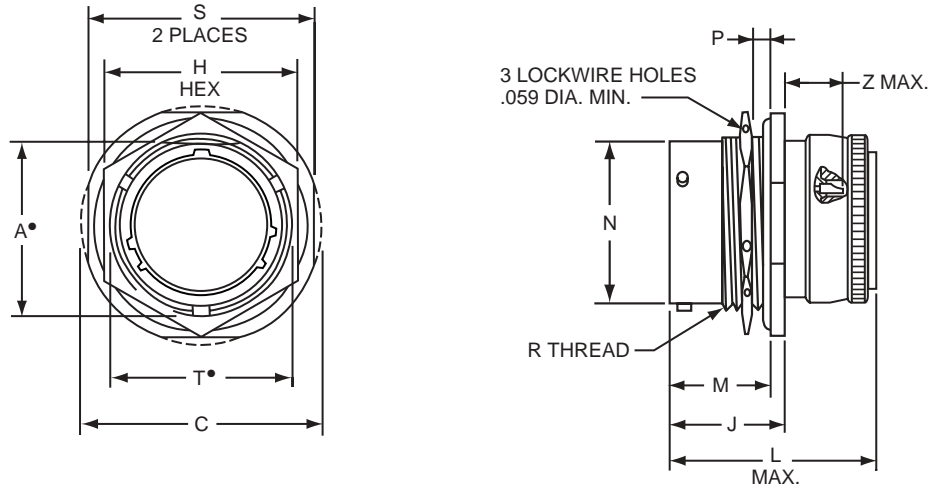

21-22X7XX-XXX

- "D" shaped mounting hole dimensions

For ordering information, see how to order page 72.

Plug movement required to clear FPT receptacles: .438 min.

Shell Size	A* Flat +.000 -.010	C Dia. +.011 -.010	H Hex +.017 -.016	J +.006 -.005	M ±.005	N Dia. +.001 -.005	P Panel Thickness		R Thread UNEF-2A (Plated)	S ±.010	T* Dia. +.010 -.000	SHORT SHELL VHF/UHF Filters	
							Max.	Min.				L Max.	Size 20 Contact Z Max.
8	.542	1.062	.750	.821	.696	.473	.125	.062	.5625-24	.938	.572	1.546	.566
10	.669	1.188	.875	.821	.696	.590	.125	.062	.6875-24	1.062	.697	1.546	.566
12	.830	1.375	1.062	.821	.696	.750	.125	.062	.8750-20	1.250	.884	1.546	.566
14	.955	1.500	1.188	.821	.696	.875	.125	.062	1.0000-20	1.375	1.009	1.546	.566
16	1.084	1.625	1.312	.821	.696	1.000	.125	.062	1.1250-18	1.500	1.134	1.546	.566
18	1.208	1.750	1.438	.821	.696	1.125	.125	.062	1.2500-18	1.625	1.259	1.546	.566
20	1.333	1.938	1.562	1.040	.884	1.250	.250	.062	1.3750-18	1.812	1.384	1.672	.440
22	1.459	2.062	1.688	1.040	.884	1.375	.250	.062	1.5000-18	1.938	1.509	1.672	.440
24	1.575	2.188	1.812	1.073	.917	1.500	.250	.062	1.6250-18	2.062	1.634	1.672	.407

All dimensions for reference only.

Amphenol FAN Connectors

filtered “AN”

The “AN” Filter Connector is designed in configurations intermateable and intermountable with MIL-DTL-5015* connectors and provides electromagnetic interference protection for critical circuits.

- Same dimensions as the non-filtered standard MIL-spec connectors with the exception of back shell length. (See Catalog 12-020).
- Uses non-removable solder cup terminated contacts.
- Shells are impact extruded or machined bar stock aluminum and are available in several conductive platings.
- Applications include power transmission, medical communications, and ground support equipment.

The following insert arrangements within the 5015 family have the same alternate insert rotations for W, X, Y and Z, which are:

Degrees			
W	X	Y	Z
80	110	250	280

16-7	20-22	22-29	24-17	28-16	32-13
18-5	22-6	22-33	24-20	28-17	32-22
18-9	22-12	22-34	24-21	28-19	32-AF
18-13	22-14	24-1	24-28	28-20	36-1
18-14	22-15	24-3	28-1	28-21	36-7
20-7	22-16	24-4	28-4	32-1	36-8
20-8	22-17	24-5	28-8	32-3	36-13
20-9	22-18	24-6	28-9	32-4	40-AR
20-12	22-19	24-7	28-10	32-6	40-AS
20-14	22-21	24-12	28-11	32-9	40-AT
20-16	22-24	24-14	28-14	32-10	40-AU
20-20	22-25	24-16	28-15	32-12	

The following are additional 5015 insert arrangements with alternate rotations.

Insert Arrangement	Degrees			
	W	X	Y	Z
10SL-4	63	-	-	-
12S-3	70	145	215	290
14S-2	-	120	240	-
14S-5	-	110	-	-
14S-7	90	180	270	-
14S-9	70	145	215	290
16-9	35	110	250	325
16-10	90	180	270	-
16-11	35	110	250	325
16-13	35	110	250	325
16S-1	80	-	-	280
16S-4	35	110	250	325
16S-5	70	145	215	290
16S-6	90	180	270	-
16S-8	-	170	265	-
18-1	70	145	215	290
18-3	35	110	250	325
18-4	35	110	250	325
18-8	70	-	-	290
18-10	-	120	240	-
18-11	-	170	265	-
18-12	80	-	-	280
18-15	-	120	240	-
18-20	90	180	270	-
18-22	70	145	215	290
18-29	90	180	270	-
20-3	70	145	215	290

* MIL-DTL-5015 supersedes MIL-C-5015.

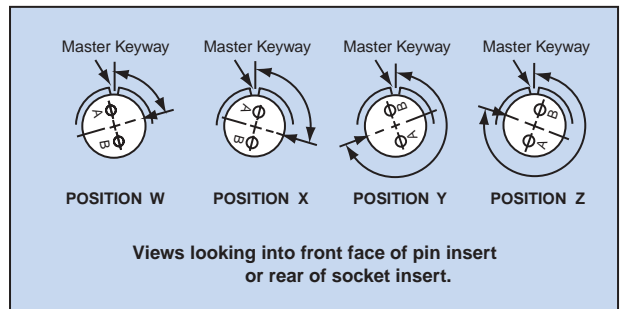

Insert Arrangement	Degrees			
	W	X	Y	Z
20-4	45	110	250	-
20-5	35	110	250	325
20-6	70	145	215	290
20-15	80	-	-	280
20-17	90	180	270	-
20-18	35	110	250	325
20-19	90	180	270	-
20-21	35	110	250	325
20-23	35	110	250	325
20-24	35	110	250	325
20-27	35	110	250	325
20-29	80	-	-	280
22-1	35	110	250	325
22-2	70	145	215	290
22-4	35	110	250	325
22-5	35	110	250	325
22-8	35	110	250	325
22-9	70	145	215	290
22-10	35	110	250	325
22-11	35	110	250	325
22-13	35	110	250	325
22-20	35	110	250	325
22-22	-	110	250	-
22-23	35	-	250	-
22-27	80	-	250	280
22-28	80	-	-	280
22-63	20	-	-	-
24-2	80	-	-	280
24-9	35	110	250	325
24-10	80	-	-	280
24-11	35	110	250	325
24-22	45	110	250	-
24-27	80	-	-	280
28-2	35	110	250	325
28-3	70	145	215	290

Insert Arrangement	Degrees			
	W	X	Y	Z
28-5	35	110	250	325
28-6	70	145	215	290
28-7	35	110	250	325
28-12	90	180	270	-
28-18	70	145	215	290
28-22	70	145	215	290
28-AY	45	110	250	-
32-2	70	145	215	290
32-5	35	110	250	325
32-7	80	125	235	280
32-8	80	125	235	280
32-15	35	110	250	280
32-17	45	110	250	-
32-25	60	120	-	-
32-48	80	-	-	-
32-64	80	100	110	250
32-68	30	-	-	-
32-82	30	-	-	-
36-3	70	145	215	290
36-4	70	145	215	290
36-5	-	120	240	-
36-6	35	110	250	325
36-9	80	125	235	280
36-10	80	125	235	280
36-14	90	180	270	-
36-15	60	125	245	305
36-AF	65	-	-	-
40-1	65	130	235	300
40-5	33	-	-	270
40-9	65	125	225	310
40-10	65	125	225	310
40-35	70	130	230	290
40-AD	45	-	-	-
40-AG	37	74	285	322
40-AP	35	110	250	325
40-AV	90	180	270	-

FAN (MIL-DTL-5015)

box mounting receptacle

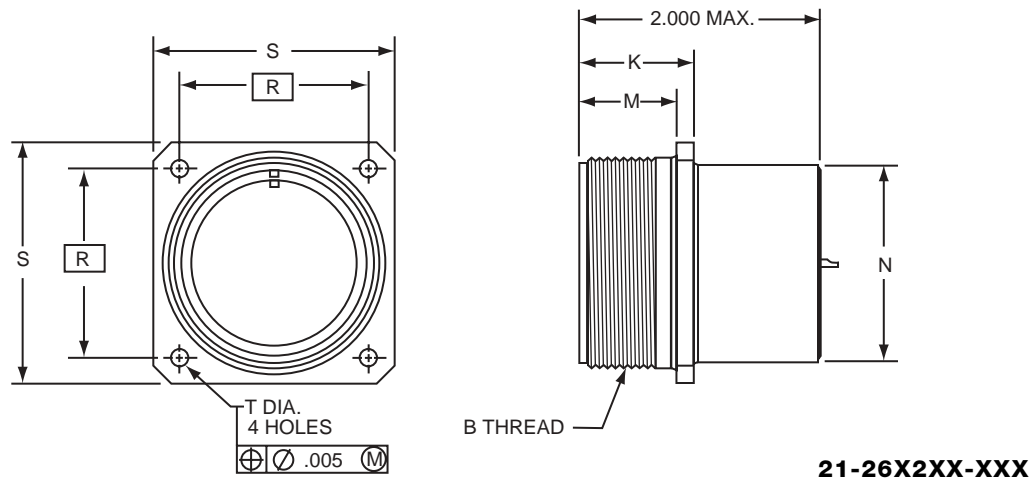

For ordering information, see how to order page 72.
 Note: MIL-DTL-5015 supersedes MIL-C-5015.

Shell Size	B Thread Class 2A (Plated)	M +.010 -.000	K +.020 -.010	N Dia. +.010 -.000	R TP	S ±.031	T Dia. +.004 -.002
8S	.5000-28 UNEF	.562	.672	.375	.594	.875	.120
10S	.6250-24 UNEF	.562	.672	.500	.719	1.000	.120
10SL	.6250-24 UNEF	.562	.672	.625	.719	1.000	.120
12S	.7500-20 UNEF	.562	.672	.625	.812	1.094	.120
12	.7500-20 UNEF	.750	.860	.625	.812	1.094	.120
14S	.8750-20 UNEF	.562	.672	.750	.906	1.188	.120
14	.8750-20 UNEF	.750	.860	.750	.906	1.188	.120
16S	1.0000-20 UNEF	.562	.672	.875	.969	1.281	.120
16	1.0000-20 UNEF	.750	.860	.875	.969	1.281	.120
18	1.1250-18 UNEF	.750	.891	1.000	1.062	1.375	.120
20	1.2500-18 NEF	.750	.891	1.125	1.156	1.500	.120
22	1.3750-18 NEF	.750	.891	1.250	1.250	1.625	.120
24	1.5000-18 NEF	.812	.953	1.375	1.375	1.750	.147
28	1.7500-18 NS	.812	.953	1.625	1.562	2.000	.147
32	2.0000-18 NS	.875	1.031	1.875	1.750	2.250	.173
36	2.2500-16 UN	.875	1.031	2.062	1.983	2.500	.173
40	2.5000-16 UN	.875	1.031	2.312	2.188	2.750	.173

All dimensions for reference only.

Amphenol® EMI/RFI Connectors

Programmable

Amphenol® Programmable Filter Connectors combine the versatility of standard crimp connectors with EMI/RFI protection for sensitive circuitry.

- Designed to filter and protect circuits from power surges, and will replace bulky filter networks that occupy critical space in electronic boxes.
- Ground, insulated or filter contacts can be combined within the same connector to accommodate unique and changing EMI requirements.
- Provides benefits not available in fixed EMI/RFI connectors.
- Crimp style EMI contacts are insertable and removable from the rear of the connector, making modification of EMI performance as simple as changing a contact.
- Connectors are repaired by replacing the damaged contact using a standard M81969 insertion and removal tool.

The table below indicates crimp frames and positioners to be used.

Contact Part No.	Contact Size	Turret**	Crimp Frame**
PFXXXXCR-22DP	22D Pin	K932	M22520/2-01
PFXXXXCR-22DS	22D Socket	K931	M22520/2-01
PFXXXXCR-20P	20 Pin	TH533	M22520/1-01
PFXXXXCR-20S	20 Socket	TH533	M22520/1-01
PFXXXXCR-16P	16 Pin	TH533	M22520/1-01
PFXXXXCR-16S	16 Socket	TH533	M22520/1-01

See L-624-3 for additional crimping, insertion and removal instructions

** Available from Daniels Mfg. Co., Inc., Orlando, FL

- Crimp contacts or contacts for printed circuit board applications are offered in a wide range of capacitance values. Pi filters are available in the VHF and UHF frequency ranges.
- Programmable EMI/RFI connectors are intermateable and intermountable with MIL-DTL-38999 Series I, II, III, and SJT.

See publication L-2057 for a complete list of attenuation values at specific capacitance ranges.

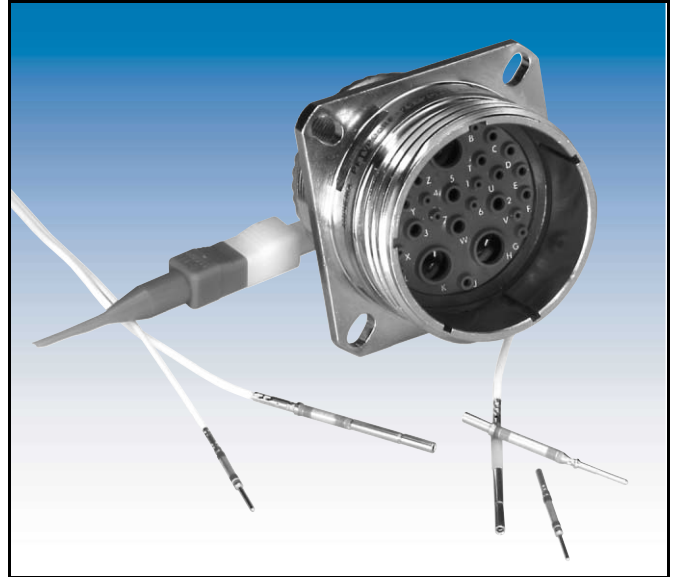

The following pages provide how to order instructions and dimensional information particular to the Programmable Filter Connector. If more information is required, contact Amphenol, Sidney, NY.

PFLJT Programmable

wall mounting receptacle, box mounting receptacle, jam nut receptacle

**WALL MOUNT RECEPTACLE
PFLJTPQ00***

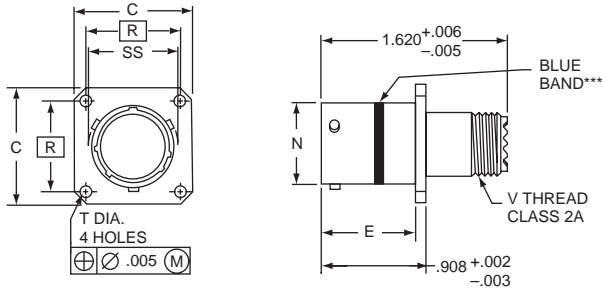

**BOX MOUNT RECEPTACLE
PFLJTP02***

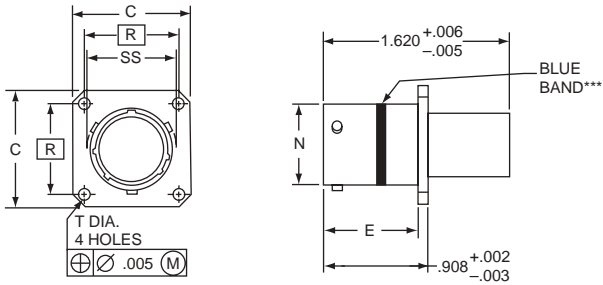

**JAM NUT RECEPTACLE
PFLJT07***

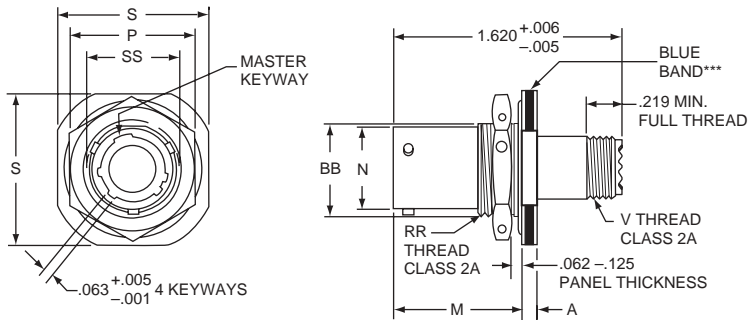

* To complete order number, see Programmable Filter how to order on page 60.

*** Blue band indicates rear release contact retention system.

Shell Size	A +.011 -.010	C +.011 -.010	E +.000 -.006	M ±.005	N Dia. +.001 -.005	P Hex +.017 -.016	R	S +.016 -.015	T Dia. +.004 -.003	V Thread	BB Flat +.000 -.010	RR Thread (Plated)	SS Dia. +.000 -.016
11	.109	1.031	.820	.915	.700	1.000	.812	1.250	.128	.5625-24UNEF	.755	.8125-20UNEF	.810
13	.109	1.125	.820	.915	.850	1.188	.906	1.375	.128	.6875-24UNEF	.942	1.0000-20UNEF	.960
15	.109	1.219	.820	.915	.975	1.312	.969	1.500	.128	.8125-20UNEF	1.066	1.1250-18UNEF	1.085
17	.109	1.312	.820	.915	1.100	1.438	1.062	1.625	.128	.9375-20UNEF	1.191	1.2500-18UNEF	1.210
19	.140	1.438	.820	.915	1.207	1.562	1.156	1.812	.128	1.0625-18UNEF	1.316	1.3750-18UNEF	1.317
21	.140	1.562	.790	.915	1.332	1.688	1.250	1.938	.128	1.1875-18UNEF	1.441	1.5000-18UNEF	1.442
23	.140	1.688	.790	.915	1.457	1.812	1.375	2.062	.147	1.3125-18UNEF	1.566	1.6250-18UNEF	1.567
25	.140	1.812	.790	.915	1.582	2.000	1.500	2.188	.147	1.4375-18UNEF	1.691	1.7500-18UNS	1.692

All dimensions for reference only.

□ Designates true position dimensions.

The LJT is a MIL-DTL-38999, Series I connector. See catalog 12-090 for additional design specifications.

The Programmable Filter LJT is interchangeable and intermountable with BS952090001 and HE308.

PFTV Programmable

wall mounting receptacle, jam nut receptacle

WALL MOUNT RECEPTACLE PFTVP00*

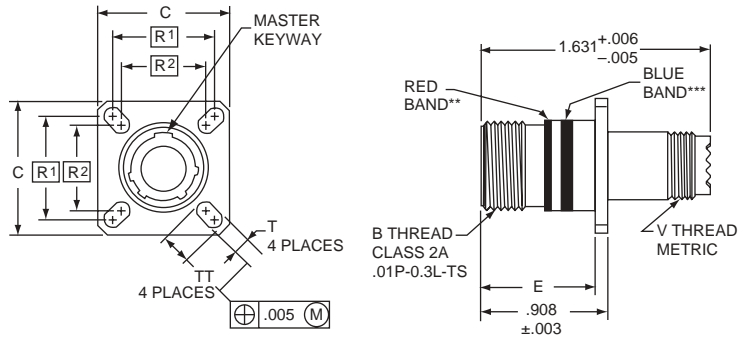

JAM NUT RECEPTACLE PFTV07*

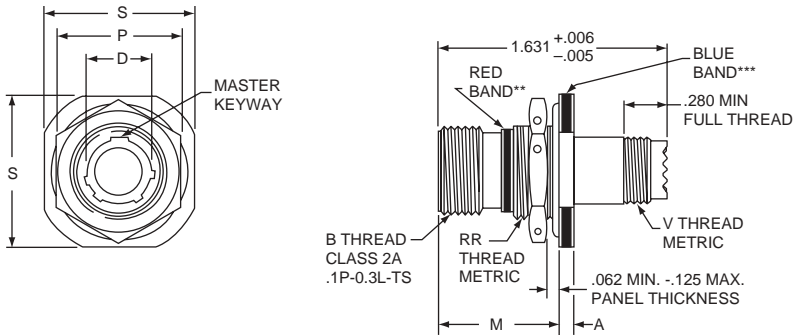

* To complete order number, see Programmable Filter how to order on page 60.

** Red band indicates fully mated.

*** Blue band indicates rear release contact retention system.

Shell Size	B Thread (Plated)	C ±.010	D Dia +.005 - .001	E +.000 - .005	M ±.005	P Hex +.017 - .016	R ₁	R ₂	S ±.010	T +.008 - .006	V Thread Metric (Plated)	RR Thread Metric (Plated)	TT +.008 - .006
11	.7500	1.031	.570	.820	.871	1.000	.812	.719	1.250	.128	M15X1-6g	M20X1-6g	.194
13	.8750	1.125	.682	.820	.878	1.188	.906	.812	1.375	.128	M18X1-6g	M25X1-6g	.194
15	1.1000	1.219	.807	.820	.878	1.312	.969	.906	1.500	.128	M22X1-6g	M28X1-6g	.173
17	1.1875	1.312	.932	.820	.878	1.438	1.062	.969	1.625	.128	M25X1-6g	M32X1-6g	.194
19	1.2500	1.438	1.037	.820	.878	1.562	1.156	1.062	1.812	.128	M28X1-6g	M35X1-6g	.194
21	1.3750	1.562	1.162	.790	.878	1.688	1.250	1.156	1.938	.128	M31X1-6g	M38X1-6g	.194
23	1.5000	1.688	1.287	.790	.878	1.812	1.375	1.250	2.062	.154	M34X1-6g	M41X1-6g	.242
25	1.6250	1.812	1.412	.790	.878	2.000	1.500	1.375	2.188	.154	M37X1-6g	M44X1-6g	.242

All dimensions for reference only.

□ Designates true position dimensions.

The TV is a MIL-DTL-38999, Series III connector. See catalog 12-092 for additional design specifications.

The Programmable Filter TV is intermateable and intermountable with BS952090003 and JN1034.

PFSJT Programmable

wall mounting receptacle, box mounting receptacle, jam nut receptacle

**WALL MOUNT RECEPTACLE
PFSJTPQ00***

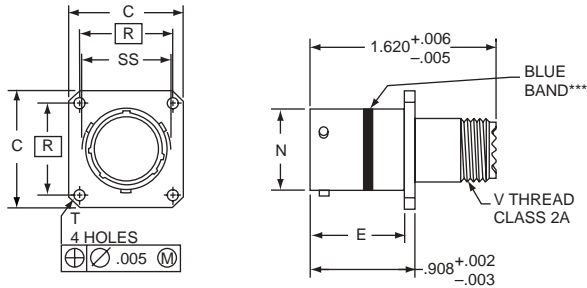

**BOX MOUNT RECEPTACLE
PFSJTP02***

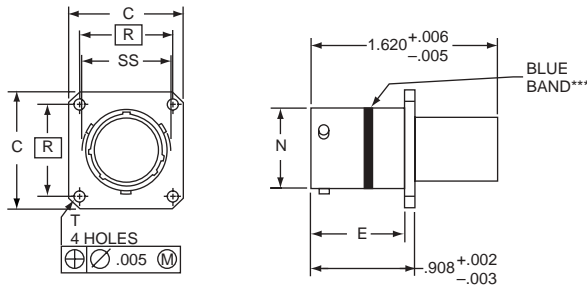

**JAM NUT RECEPTACLE
PFSJT07***

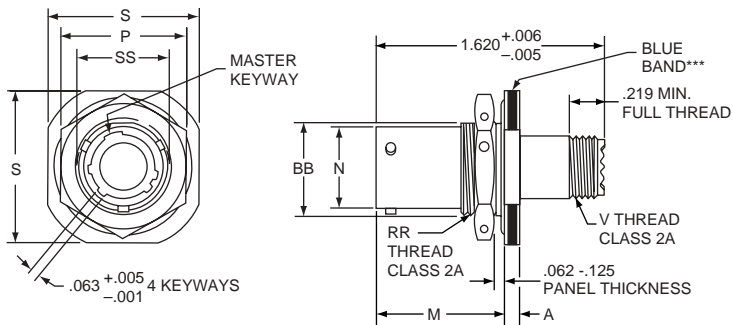

* To complete order number, see Programmable Filter how to order on page 60.

*** Blue band indicates rear release contact retention system.

Shell Size	A +.011 -.010	C +.011 -.010	E +.000 -.006	M ±.005	N Dia. +.001 -.005	P Hex +.017 -.016	R	S +.016 -.015	T Dia. +.004 -.003	V Thread	BB Flat +.000 -.010	RR Thread (Plated)	SS Dia. +.000 -.016
10	.109	.938	.820	.915	.590	.875	.719	1.062	.120	.5625-24UNEF	.669	.6875-24UNEF	.680
12	.109	1.031	.820	.915	.750	1.062	.812	1.250	.120	.6875-24UNEF	.830	.8750-20UNEF	.859
14	.109	1.125	.820	.915	.875	1.188	.906	1.375	.120	.8125-20UNEF	.955	1.0000-20UNEF	.984
16	.109	1.219	.820	.915	1.000	1.312	.969	1.500	.120	.9375-20UNEF	1.084	1.1250-18UNEF	1.108
18	.140	1.312	.820	.915	1.125	1.438	1.062	1.625	.120	1.0625-18UNEF	1.208	1.2500-18UNEF	1.233
20	.140	1.438	.790	.915	1.250	1.562	1.156	1.812	.120	1.1875-18UNEF	1.333	1.3750-18UNEF	1.358
22	.140	1.562	.790	.915	1.375	1.688	1.250	1.938	.120	1.3125-18UNEF	1.459	1.5000-18UNEF	1.483
24	.140	1.688	.790	.915	1.500	1.812	1.375	2.062	.147	1.4375-18UNEF	1.580	1.6250-18UNS	1.610

All dimensions for reference only.

□ Designates true position dimensions.

The SJT is a proprietary connector. See catalog 12-091 for additional design specifications.

The Programmable Filter SJT complies with VG96912 for intermating and intermounting.

Programmable EMI/RFI

how to order

Programmable Filter Connector part number breakdown, less contacts for connector LJT, SJT and TV types:

PF	LJT	P02RT	25	-	35	P	A	(XXX)	(B)
1	2	3	4		5	6	7	8	9

1. PF designates Programmable Filter
2. Connector Series*:
LJT
TV (Tri-Start)
SJT
JT (for availability, consult Amphenol, Sidney, NY)
3. Shell Style, Service Class and Finish:
LJT/SJT (style & class only, finish designated by variation suffix):
P02RT (box mount)
PQ00RT (wall mount)
07RT (jam nut)

TV:
P00RF (wall mount electroless nickel)
P00RW (wall mount O.D. cadmium)
07RF (jam nut electroless nickel)
07RW (jam nut O.D. cadmium)
4. Shell Size:
LJT/TV: 9 through 25
SJT: 8 through 24
5. Insert Pattern - refer to insert availability chart on page 9
6. Insert Gender: Pin or Socket
7. Alternate Shell Position:
LJT/SJT: A through D
TV: A through E
8. Variation Suffix
Finish designation for LJT/SJT:
(023) electroless nickel
(014) O.D. cadmium
9. "B" or "W" - indicates source of origin**

* Connector Series:

LJT is a MIL-DTL-38999, Series I connector. See catalog 12-090 for additional design specifications.

TV (Tri-Start) is a MIL-DTL-38999, Series III connector. See catalog 12-092 for additional design specifications.

SJT is a proprietary connector. See catalog 12-091 for additional design specifications.

JT is a MIL-DTL-38999, Series II connector. See catalog 12-090 for additional design specifications.

** B designates Amphenol® from Amphenol, Sidney, N.Y., U.S.A.

W designates Amphenol Limited, Whitstable, England

*** Contact Amphenol for availability

Programmable Filter Contacts***

Part Number Breakdown:

PF	49	2	1	CR	22D	P	(XXX)	(B)
1	2	3	4	5	6	7	8	9

1. PF designates Programmable Filter
2. Significant figures of capacitance (in PF)
for example: 4900 = 49
3. Multiplier (No. of zeros)
4. Filter Circuit:
1 = Pi Filler
8 = Ground
9 = Feed-thru
5. Termination Style:
CR designates Crimp
PR designates Printed Circuit Tail
6. Contact Size:
16, 20, 22D
7. Contact Gender: Pin or Socket
8. Contact Variation Suffix
9. "B" or "W" - indicates source of origin**

Capacitor Color Coding

Filter Type	Color
UHF ₁	Violet
UHF ₂	Pink
VHF ₁	Green
VHF ₂	Brown

Amphenol® Filter Adapters

effective circuit protection for existing applications

Filter adapters present an effective and economical method of introducing EMI/EMP protection to an installed system. The adapter series of filter connectors from Amphenol are available to intermate with all the popular MIL-Specs.

Features of the Amphenol® adapter include:

- Planar technology from the industry's leader in cylindrical filter products
- MOV or diode capability for transient protection
- Wide range of tooled patterns
- Space qualified components

Installation of the adapter is quick and efficient, requiring no tools, fixtures or extended downtime. Simply unmate the existing cable harness from the receptacle; attach the coupling nut to the receptacle on the unit; then mate the cable harness to the receptacle side of the adapter.

Several design alternatives are available that will help ensure that the adapter remains permanently attached to either the cable harness or the unit receptacle.



FPT, FJT, FLJT, FTV adapters

**FPT Adapter
21-900075-XX**

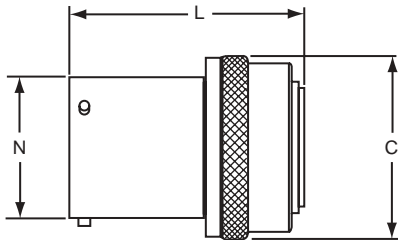

FPT Shell Size	C Dia. Ref.	N Dia. +.001 - .005	L Max.
8	.729	.473	1.626
10	.851	.590	1.626
12	1.035	.750	1.626
14	1.158	.875	1.626
16	1.280	1.000	1.626
18	1.403	1.125	1.626
20	1.525	1.250	1.688
22	1.648	1.375	1.688
24	1.770	1.500	1.688

**FJT Adapter
21-900393-XX**

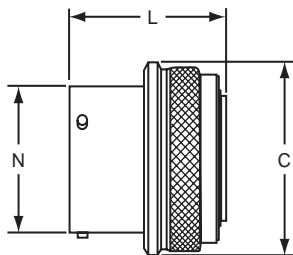

FJT Shell Size	C Dia. +.011 - .010	N Dia. +.001 - .005	L Max.
8	.847	.473	1.397
10	.969	.590	1.397
12	1.143	.750	1.397
14	1.255	.875	1.397
16	1.388	1.000	1.397
18	1.510	1.125	1.397
20	1.633	1.250	1.397
22	1.756	1.375	1.397
24	1.878	1.500	1.397

**FLJT Adapter
21-900423-XX**

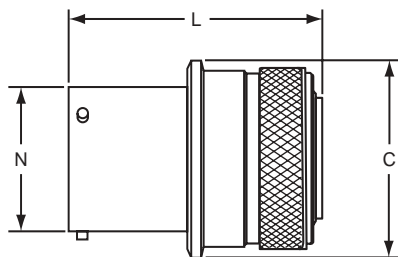

FLJT Shell Size	C Dia. +.011 - .010	N Dia. +.001 - .005	L Max.
9	.920	.572	2.038
11	1.045	.700	2.038
13	1.246	.850	2.038
15	1.371	.975	2.038
17	1.496	1.100	2.038
19	1.616	1.207	2.038
21	1.743	1.332	2.038
23	1.866	1.457	2.038
25	1.991	1.582	2.038

**FTV Adapter
21-900529-XX**

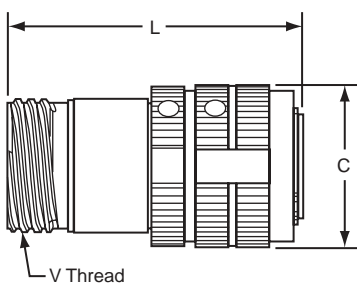

FTV Shell Size	C Dia. Ref.	V Thread 0.1P-0.3L-TS Class 2A	L Max.
9	.845	.6250	2.257
11	.950	.7500	2.257
13	1.121	.8750	2.257
15	1.249	1.0000	2.257
17	1.386	1.1875	2.257
19	1.493	1.2500	2.257
21	1.620	1.3750	2.257
23	1.737	1.5000	2.257
25	1.864	1.6250	2.257

All dimensions for reference only.
Consult Amphenol, Sidney, NY for ordering information.

Amphenol® Transient Protection

MOV – Metal Oxide Varistor Connectors

- Filter connector size package
- Protection for 14, 31, 38 DC voltage circuits
- Radiation hardened
- No additional circuits required
- Low impedance
- Increased reliability
- Nanosecond response time
- Elimination of costly external suppression assemblies

The Amphenol® MOV Connector offers the versatility of a standard connector, with transient protection for sensitive circuits.

Transients in electrical circuits caused by a sudden release of stored energy can originate within or outside of the circuit and may be repeatable or random.

Regardless of frequency or origin, transient caused failures generated by load switching, lightning, electrostatic discharge (ESD) and electromagnetic pulse (EMP) can destroy unprotected IC components.

Compatible with present filter connector assembly procedures, MOVs can be combined with existing filters. Internal housing of the MOV sleeve offers weight and space savings over other protection methods available today, and eliminates costly and bulky exterior suppression mechanisms in appropriate situations. MOVs are presently available in contact sizes 22, 20 and 16.

Transient protection can be provided in receptacle, plug or adapter configuration. These connectors are intermateable and intermountable with the following MIL-Specs:

- MIL-DTL-5015
- MIL-C-26482
- MIL-C-26500
- MIL-C-27599
- MIL-DTL-38999
- MIL-C-83723



MOV Connectors, cont.

M.O.V. PERFORMANCE CHARACTERISTICS

Designation	Contact Size	Maximum Ratings (125°C)				Specifications (25°C)						Maximum Leakage Current at V_t (dc)			
		Continuous		Transient		Varistor Voltage at 1mA (DC)			Maximum Clamping Voltage V_C at Test Current I_p (8/20 μ S)		Capacitance at 1 MHz		I_L Max.	I_L Max.	V_t
		DC Voltage	RMS Voltage	Energy (10/1000 μ S)	Peak Current (8/20 μ S)										
		V_m Volts	V_m Volts	W_{tm} Joules	I_{tm} Amperes	Min. Volts	V_N (dc) Volts	Max. Volts	V_C Volts	I_p Amps	PicoFarads		25°C	125°C	DC Volts
									Min.	Max.	μ A	μ A			
F14	22	14	10	1.5	250	18	22	26	42	10	1000	3000	5	50	14
F31	22	31	25	1.5	250	35	39	48	85	5	450	1950	5	50	28
F38	22	38	30	1.5	250	42	47	58	100	5	400	1500	5	50	36
F31	20	31	25	2	300	35	39	48	85	10	450	1950	5	50	28
F38	20	38	30	2	300	42	47	58	100	10	400	1500	5	50	36
F38	16	38	30	3	350	42	47	58	100	20	450	1950	5	50	36

NOTE: Continuous voltage ratings are based on 1000 hour reliability assurance tests at 125°C rated ambient temperature per MIL-STD-202 Method 108. Contact Amphenol Sidney for options not listed in chart.

The following charts show the typical MOV response to an input pulse open circuit of 1000V and 10A peak square wave with a 5 nanosecond rise time in a 50 Ohm system.

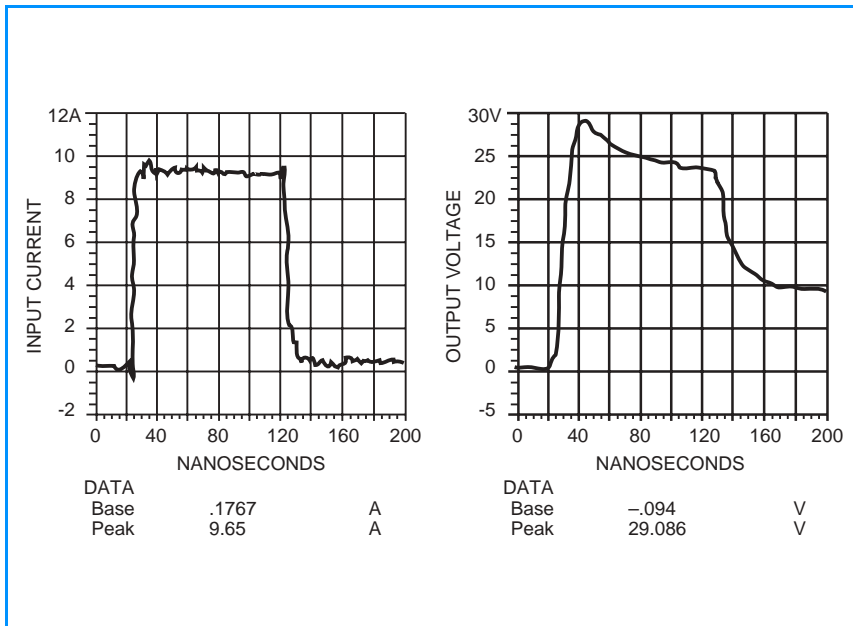

The following chart shows response time and output voltage of a typical MOV with 1000V, 5 nanosecond, 2.5A input pulse mounted in an LJT 13-35P connector. Test was performed without load.

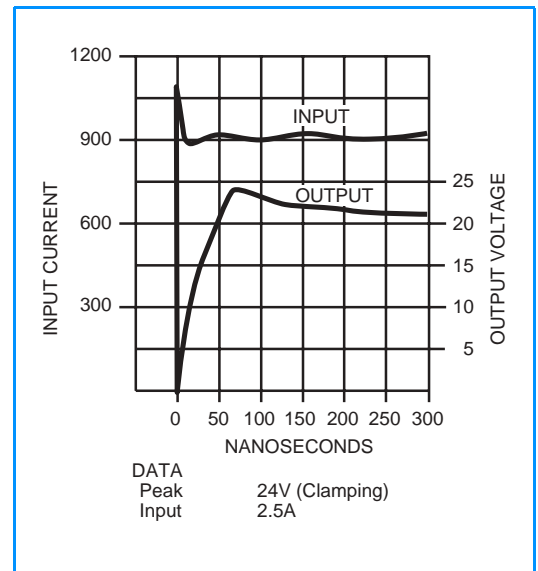

Amphenol® Transient Protection Diode Connectors

- Clamping voltage as low as 11.9 volts
- Low capacitance – suitable for high frequency applications
- Unipolar or bipolar – using existing proven diode technology
- Protection for 5.8 to 60 VDC circuits
- No additional circuits required
- Low impedance – high frequency response
- Increased reliability
- Nanosecond response time
- Elimination of costly external suppression assemblies
- Screening to applicable requirements of MIL-S-19500TX/ TXV available
- Keeps transients outside of the box
- Minimizes fast transient voltage overshoot

The Amphenol® Diode Connector offers the versatility of a standard connector, with transient protection for sensitive circuits, such as TTL Lines.

Transients in electrical circuits caused by a sudden release of stored energy can originate within or outside of the circuit and may be repeatable or random.

Regardless of frequency or origin, transient caused failures generated by load switching, lightning, electrostatic discharge (ESD) and electromagnetic pulse (EMP) can destroy unprotected IC components.

Compatible with present filter connector assembly procedures, diodes can stand alone or can be combined in series with filters. Internal housing of the diode offers weight and space savings over other protection methods available today, and eliminates costly and bulky exterior suppression mechanisms in appropriate situations. Diodes are presently available in contact sizes 22 and 20.

Transient protection can be provided in receptacle, plug or adapter configurations. These connectors are intermateable and intermountable with the following MIL-Specs:

- MIL-DTL-5015
- MIL-DTL-27599
- MIL-C-26482
- MIL-DTL-38999
- MIL-C-26500
- MIL-C-83723



Diode Connector and Adapter



Close-up View of Diode Contact

Diode Connectors, cont.

STANDARD DIODE CONNECTOR CHARACTERISTICS AT 25 °C

Stand-off Voltage † (VDC)	Max. Capacitance* (pf)	Breakdown Voltage at 1 ma (VDC)	Max. Clamping Voltage (8 x 20µ sec. pulse)	Leakage Current at Stand-off Voltage (µA)	Power Capability † 20µs Exp. Impulse (Peak) (Watts)
+ 5.8	1600	+ 6.45 to + 7.1**	+11.9	<100	1000
± 5.8	1000	± 6.45 to ± 7.1**	±11.9	<150	1000
± 7.0	750	± 7.3 to ± 9.3	±13.5	<10	1000
± 8.0	750	± 8.2 to ±10.6	±15.4	<5	1000
+ 8.0	1500	+ 8.5 to +10.6	+15.4	<5	1000
±10.0	500	±11.1 to ±12.3	±17.0	<1	1000
+10.0	1100	+11.1 to +12.3	+17.0	<1	1000
±15.0	500	±16.7 to ±18.5	±24.9	<1	1000
+15.0	750	+16.2 to +19.2	+24.9	<1	1000
-15.0	750	-16.2 to -19.2	-24.9	<1	1000
±17.0	500	±18.9 to ±23.0	±32.0	<1	1000
+17.1	600	+19.0 to +21.0	+27.7	<1	1000
±22.0	500	±25.7 to ±28.4	±38.0	<1	1000
±25.0	500	±27.8 to ±30.7	±40.5	<1	1000
+28.0	500	+30.5 to +35.7	+46.4	<1	1000
±33.3	500	+37.1 to +41.0	±53.9	<1	1000
+33.3	500	+37.1 to +41.0	+53.9	<1	1000
±40.0	500	±44.4 to ±49.1	±64.5	<1	1000
±45.0	500	±47.1 to ±58.1	±84.2	<1	1000
+57.8	500	+64.6 to +71.4	+95.2	<1	1000
±57.8	500	±64.6 to ±71.4	±95.2	<1	1000

Clamping Time -

Unipolar: Less than 1 nanosecond, 0V to breakdown

Bipolar: Less than 5 nanoseconds, 0V to breakdown

* Lower capacitance devices available; consult Amphenol, Sidney, NY.

**This device only measured at 10ma

† Higher power ratings also available

DIODE CONTACT PULSE TEST, ±5.8 DIODE

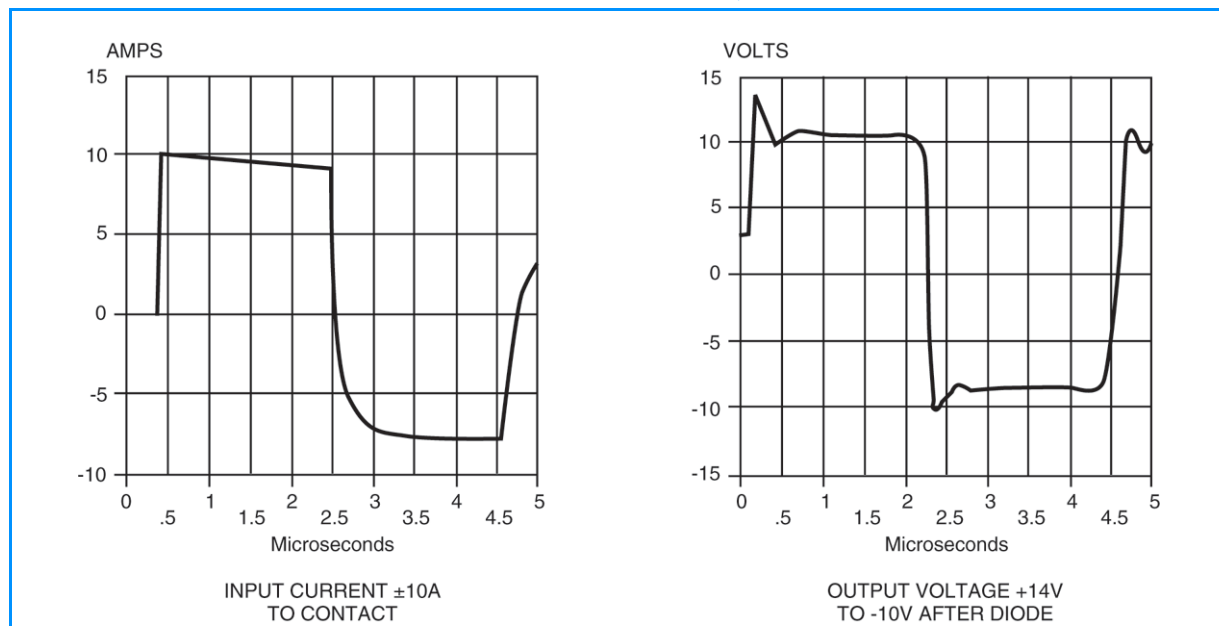

Amphenol® Transient Protection

ESA – Energy Shunting Assembly

The Amphenol® Energy Shunting Assembly (ESA) is a simple, compact unit which provides lightning and electromagnetic pulse (EMP) protection of systems in which many signal lines enter sensitive electronic equipment. The efficient packaging of the ESA circumvents the concept of one protective device per line. It provides a surge arrester which has the advantage of space saving and simplified assembly when compared to current protective devices which range from diodes to large spark gaps.

The current ESA design consists of two 53-pin contact, Mil-Standard, hermetic connectors assembled back to back, and encompassing a ground plate. A sealed chamber is formed within this thru-bulkhead unit, housing 53 in-line spark gaps. Introducing a controlled atmosphere enhances fast rise breakdown.

The ESA can be integrated with an EMI filter connector which can improve its performance. These two assemblies provide a method to help protect against lightning, EMP, EMI and TEM-PEST effects.



Performance Characteristics

1. DC breakdown voltage	230 Volts	
2. Maximum rated surge discharge current (8 x 20 microsecond pulse)	5,000 Amperes per pin	
3. Insulation resistance	10 ¹⁰ ohms minimum	
4. Capacitance between each electrode and the ground plane	Less than 2 pf	
5. Rate-of-rise breakdown voltage	Maximum Breakdown Voltage (Volts)	Rate of Rise (Volts/microsecond)
	600	10
	800	1,000
	1,500	10,000
	2,000	1000,000
6. Surge breakdown unbalance (at 100 Volts/microseconds)	180 Volts	
7. Surge life (500 Ampere – 10 x 1,000 microsecond)	400 Surges	
8. Hold-over voltage	100 Volts	
9. Arcing voltage	40 Volts	
10. Glow to arc transition point	1 Ampere	
11. Temperature range	-40°F to 150°F (233°K to 339°K)	

Filter Accessories

Universal “Header Assembly” for flex print or PC board connectors

Mounts to all MIL-DTL-38999 and MIL-C-26482 Connectors

The use of connectors with printed circuit termination is rapidly gaining popularity due to the use of high volume, vapor phase or wave solder manufacturing processes. Termination of this style of connector to flex print or a printed circuit board represents a major cost in the manufacturing process for users. When adding flex or printed circuit board assemblies to an expensive filter or filter/transient protection connector, the total cost of a failed solder joint, a bent pin, or an unanticipated electrical failure becomes prohibitive. The universal header assembly from Amphenol will provide for easy separation of the connector from the board on these occasions.

Header Assemblies Provide Cost Savings

Incorporation of the header assembly provides the user with time and cost saving potentials. These header assemblies can be vapor phase or wave soldered to flex or printed circuit boards prior to the receipt of the EMI/EMP connector. Headers can be installed to standard connectors, allowing for electrical testing that would adversely affect the sensitive diodes, MOV's or capacitors in the EMI/EMP connectors. Expensive connector assemblies can be easily removed from and reattached to the header assembly as the manufacturing process dictates.

Mounting Applications

Shell modifications are recommended, but are not necessary. The header assembly can be attached to connectors with standard flange placement or directly to the circuit board. The ideal application would involve either a single flange moved all the way to the rear of the connector or a double flange. Cinch nuts can be installed in either flange to allow easier mounting to the panel or the header assembly. The forward flange would mount the connector to the panel; the rear flange would be used to mount the header assembly. Various types of captivated or loose attaching screws can be utilized for unique applications.

Amphenol universal headers are slotted to allow mounting to all series of MIL-DTL-38999 or MIL-C-26482 connectors without special alterations. They are of similar dimension as the flange of the mounting connector and would be approximately .185 inches (4.70 mm) thick.

Incorporates a Shorter Pin/Socket Contact

The heart of the header assembly is a short pin/socket contact. The tall of the contact would accommodate standard through-hole diameter and thickness of the flex or printed circuit board materials. The socket is imbedded in the molded material, making electrical engagement with the printed circuit tail of the connector.

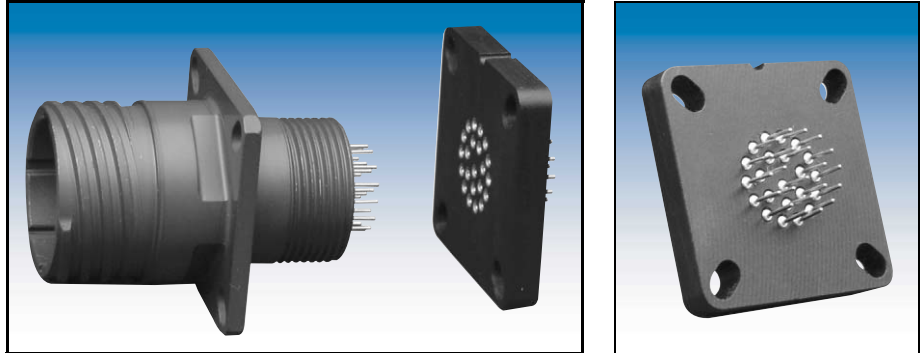

Headers provide easy separation of the connector from the PC board.

Cylindrical Configuration

- 3 PCB stickout dimensions are available.
- Size 22D contacts use .175 thick headers
- Size 16 to 20 contacts use .195 thick headers
- Consult Amphenol, Sidney NY for additional configurations.
- Headers for cylindrical connectors accommodate up to 128 pins. Consult Amphenol catalogs for mating connector contact layouts (12-092 and 12-090 for MIL-DTL-38999 and 12-070 for MIL-C-26482).

Mounting to Rectangular ARINC Connectors

- Headers for ARINC connector arrangements accommodate up to 150 pins.
- Consult Amphenol, Sidney NY for ARINC configurations and detailed dimensions.

Materials

- Body is molded from Torlon or PPS (Polyphenylene Sulfide)
- Electrical engagement areas of the header contact are plated with .00003 inches minimum of gold over .00005 inches minimum of nickel.

Filter Accessories

Universal "Header Assembly" for flex print or PC board connectors, cont.

The drawing below shows the standard universal adapter for use with MIL-DTL-38999 and MIL-C-26482 connectors. Consult Amphenol, Sidney, NY for drawings of headers for ARINC configurations.

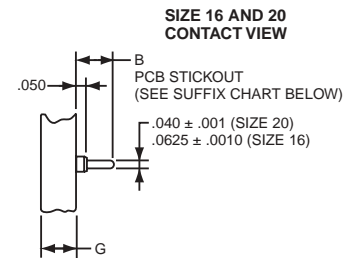
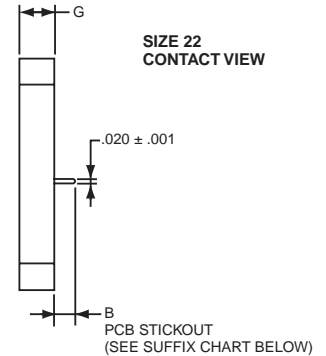
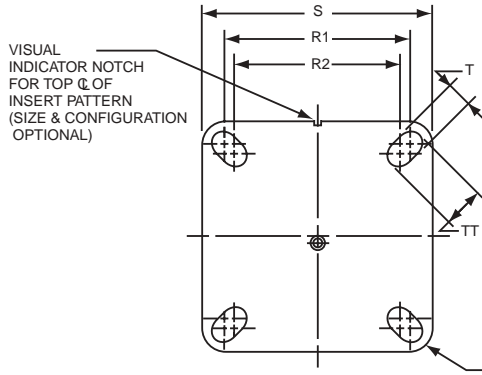

Assembly Part Number	Shell Size	F Radius	G ±.005	S ±.005	T +.008 - .006	R1 TP†	R2 TP†	TT +.008 - .006
21-904008-XX()	8/9	.094		.938	.128	.719	.594	.216
21-904010-XX()	10/11	.094		1.031	.128	.812	.719	.194
21-904012-XX()	12/13	.094		1.125	.128	.906	.812	.194
21-904014-XX()	14/15	.125		1.219	.128	.969	.906	.173
21-904016-XX()	16/17	.125		1.312	.128	1.062	.969	.194
21-904018-XX()	18/19	.125		1.438	.128	1.156	1.062	.194
21-904020-XX()	20/21	.125		1.562	.128	1.250	1.156	.194
21-904022-XX()	22/23	.125		1.688	.154	1.375	1.250	.242
21-904024-XX()	24/25	.125		1.812	.154	1.500	1.375	.242

See Suffix Chart

Assemblies containing Size 22 contact only: .175
Assemblies containing Size 16 or 20 contacts: .195

† TP designates true position dimensioning.

NOTE:
Size 22 accepts .018 to .022 dia. PCB tails.
Size 16 accepts .048 to .064 dia. PCB tails.
Size 20 accepts .037 to .043 dia. PCB tails.

HOW TO ORDER INFORMATION

For Universal Adapter used with MIL-DTL-38999 and MIL-C-26482 Connectors

Use coded number as follows:

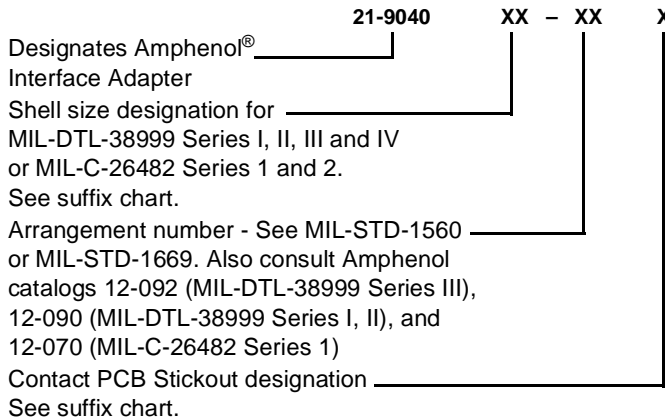

For how to order information on adapters to be used with ARINC connectors, consult Amphenol Aerospace, Sidney NY.

ASSEMBLY NUMBER SUFFIX CHART

Shell Size Designation*	Arrangement Number Suffix***	Contact PCB Stickout**	
		Suffix	B ±.015 Stickout
08	Insert Arrangement Suffix from MIL-STD-1560 or MIL-STD-1669	1	.120
10		2	.185
12		3	.270
14			
16			
18			
20			
22			
24			

* Shell size designation for MIL-DTL-38999 Series I, II, III & IV and MIL-C-26482 Series 1 and 2.
Examples: Shell size 9 use 08. Shell size 25 use 24.

** Size 22 contacts available in all 3 stickout lengths. Size 16 and 20 contacts available only in .185 and .270 lengths.

*** Insert arrangement 14-97 and 15-97 are not available at this time. Consult Amphenol, Sidney, NY for information.

Filter Accessories

Amphenol Electrostatic Discharge (ESD) Protected Connectors

Amphenol has developed cylindrical and rectangular connectors which protect sensitive components from Electrostatic Discharge (ESD) without diodes, varistors, gas tubes, or “experimental” semiconductive materials.

These connectors utilize the Faraday Cage principal to shunt electrostatic discharge events to the conductive enclosure on which the connector is mounted, thus never allowing the high voltage, high current discharge event to reside on any contacts.

The ESD protected connectors have the same physical envelope as their standard counterparts, and do not require special mounting or terminating techniques. All of the contacts remain fully functional, and electrical characteristics such as capacitance are not effected.

Product Features:

- Connector envelope identical to unprotected design for most applications
- Exceeds Protection Requirements of IEC 801-2 and MIL-STD-1686:
- Ensures that All Components within a Conductive Enclosure will be Subjected to a Maximum of 10V during Electrostatic Discharges between – 26 KV and +26 KV
- Voltage Observed on Contacts during ESD Events – <10V (at 1 megohm)
- Current Observed on Contacts during ESD Events – <100 milliamperes (at 2 ohms)
- Response Time – Instantaneous (Voltage and Current are Maximum Values)
- Maximum ESD Voltage – Tested to $\pm 26KV$
- No Capacitive Loading
- Eliminates the Need for Discrete Components (such as diodes) and Maximizes Printed Circuit Board Real Estate for Equipment Housed in Conductive Enclosures which require ESD Protection as Free-standing Units
- Operating Voltage of Connectors not Effected for Most Designs
- Pulse Life – Infinite

What is Electrostatic Discharge (ESD)?

Electrostatic Discharge (ESD) is the rapid transfer of a static electric charge from one body to another. A static electric charge consists of either a surplus or depletion of electrons on a body, which gives that body a potential or voltage relative to ground (or another body). The discharge is extremely fast (less than 1 nanosecond risetime) and the current flow may exceed 100 amps!

Static electricity is normally the result of two materials transferring charges when rubbed or separated, such as shoes scuffing across a dry carpet, or sheets of untreated plastic being separated. This phenomena is commonly referred to as the **triboelectric effect**.

The voltage developed due to the **triboelectric effect** depends on the materials involved, the quantity and type of contact, and relative humidity. In a dry environment a person can accumulate a charge of up to 25 KV! In a moist environment a person’s potential is reduced due to the effect of moisture on the insulating properties of materials.

For further information see:

Amphenol Product Data Sheet #171-1 Amphenol Electrostatic Discharge (ESD) Protected Connectors.

Amphenol Publication L-2075, “ESD Attenuation Test Procedure for Connectors with Faraday Cage Protective Structures”

* For further information on Amphenol LRM connectors with ESD

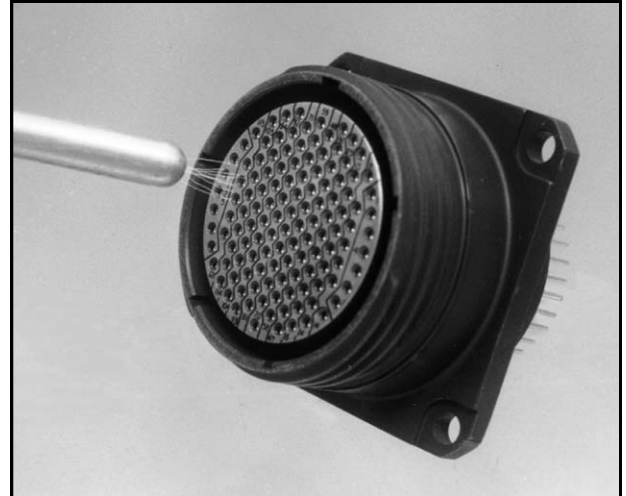

ESD Testing on MIL-DTL-38999, Series III Filter Cylindrical Connector (Actual Photo)

What is a Faraday Cage?

A **Faraday cage** is a conductive enclosure. It may be solid in form such as a sheet-metal enclosure, or it may be full of apertures, such as a wire cloth box. When a charge is placed on a faraday cage the electrons which make up the charge, having like polarity, try to position themselves as far as possible from each other. This places the electrons on the outer surface of the enclosure, leaving the inner surface uncharged. The charge on the outer surface does not induce a charge on any neutral object inside of the faraday cage, and therefore does not try to transfer itself onto the internal object. Neutral objects (such as IC’s) inside of a faraday cage are thereby protected from ESD activity external to the faraday cage.

The voltage and current observed on neutral objects within a faraday cage during ESD events are due to the secondary effects of ESD. These include Electromagnetic Interference (EMI), magnetic and electrical field coupling. The faraday cage of the Amphenol ESD Protected Connectors has been designed to minimize these effects.

The Amphenol® ESD Protected Connectors

The Amphenol® ESD Protected Connectors have a faraday cage at the mating interface. The faraday cage has been specifically designed to intercept electrostatic discharges from the contacts in the unmated state, while maintaining each contact’s isolation when the connector is mated. When the ESD Protected Connectors have been mounted to a conductive enclosure, a faraday cage is created which will protect components located within the enclosure from electrostatic discharges. This eliminates the need for discrete components such as diodes and gas discharge tubes, and saves printed circuit board real estate. Amphenol ESD Protected Connectors have also been applied to Line Replaceable Modules (LRM).*

How to Order Filter Connectors

The following format is suggested when ordering Amphenol® EMI filter connectors:

- Fill out the EMI Filter Connector check list on the next page. This check list page can be copied, filled out and sent to an Amphenol technical support person. Fax it to 607-563-5157 and a filter connector specialist will help you. It is also available on-line at www.amphenol-aerospace.com/products_filter.html.
- Choose the contact and attenuation characteristics required. (see pages 5 and 6).
- Choose the contact size and insert arrangement. Refer to corresponding Mil-Spec or go to the applicable Amphenol detailed connector catalog as follows:
 - 12-092, MIL-DTL-38999, Series III Tri-Start Connectors
 - 12-090, MIL-DTL-38999, Series I & II, LJT & JT Connectors
 - 12-070, MIL-C-26482, Series 1 Connectors
 - 12-020, MIL-C-5015 Connectors
 These detailed catalogs are all available on-line at www.amphenol-aerospace.com.
- Choose the shell style that fits your application. Refer to each of the style sections in this catalog:



Filter Connector Type	Filter Connector Brief Description	Pages
FCTV	MIL-DTL-38999 Series III with Composite shell	9-13
FTV	MIL-DTL-38999 Series III with Metal shell	14-20
FJT	MIL-DTL-38999, Series II	21-27
FLJT	MIL-DTL-38999 Series I	28-37
FSJT	Proprietary 38999 type	38-43
FBL	MIL-DTL-38999 Series IV	44-46
FPT	MIL-C-26482	47-53
FAN	MIL-DTL-5015	54-55

- To arrive at part number, see page 73, How to Order.

How to Order

Ordering procedure for example part number 21-209216-26P is shown below. If further assistance is needed to determine your filter connector requirements and order number(s), see the EMI Filter Check List on the next page and/or consult Amphenol Aerospace, Sidney, NY.

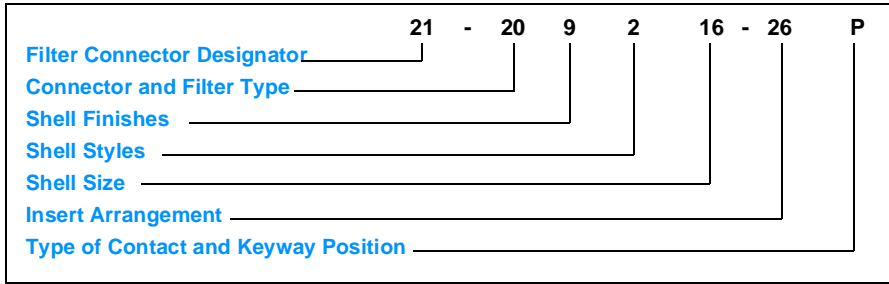

-2XX

Any combination of filters, non-filters, grounds, and non-standard contact terminations will require -2XX suffix. Please consult Amphenol Aerospace for assistance in setting up these part numbers.

- Standard voltage for diode is ± 8 volts. Any deviation requires a -2XX suffix.
- Standard voltage for a MOV is 47 volts. Any deviation requires a -2XX suffix.
- Standard diode/filter combination is ± 8 volt/VHF-1 filter. Any deviation requires a -2XX suffix.
- Standard MOV/filter combination is 47 volt/VHF-1 filter. Any deviation requires a -2XX suffix.

21 Filter Connector Designator

- 21 - Filter Connector
- 36 - MOV Connector
- 47 - Diode Connector

20 Connector/Filter Type

- 20 - FPT with VHF-1 filter (short shell)
- 22 - FPTE with VHF-1 filter (short shell)
- 24 - FJT with VHF-1 filter (short shell)
- 25 - FJT with ± 8 volt diode/VHF-1 filter combination
- 26 - FAN with VHF-1 filter
- 29 - FLJT with VHF-1 filter (short shell)
- 31 - FPT with MF filter (short shell)
- 32 - FJT with MF filter (short shell)
- 33 - FPT with HF filter (long shell)
- 34 - FJTP with VHF-1 filter (short shell)
- 36 - FLJT with HF filter (long shell)
- 37 - FJT with HF filter (long shell-min. penetration also available)
- 38 - FJTP with HF filter (long shell)
- 39 - FJTP with MF filter (short shell)
- 40 - FLJT with MF filter (short shell)
- 41 - FJT (UTS) with VHF-1 filter (short shell)
- 46 - FPT (UTS) with VHF-1 filter
- 47 - FLJTPQ with VHF-1 filter (short shell)
- 48 - FLJTPQ (UTS) with VHF-1 filter (short shell)
- 50 - FTV (UTS) with VHF-1 filter (short shell)
- 51 - FTV (UTS) with HF filter (long shell)
- 52 - FTV with VHF-1 filter (short shell)
- 53 - FTV with HF-1 filter (long shell)
- 56 - FJTP (UTS) with VHF-1 filter
- 57 - FLJT with VHF-1 filter (printed circuit mount)
- 58 - FJTPQ (UTS) with VHF-1 filter (short shell)
- 60 - FTV with VHF-1 filter (printed circuit board mount, mod. flange)
- 61 - FBL with VHF-1 filter (short shell)
- 63 - FSJT with VHF-1 filter (short shell)
- 64 - FBL (UTS) with VHF-1 filter
- 65 - FSJT (UTS) with VHF-1 filter
- 67 - FTV with VHF-1 filter (printed circuit board mount, Std. flange)
- 68 - FTV (UTS) with ± 8 volt diode/VHF-1 filter combination
- 69 - FLJT with programmable filter
- 70 - FJT with programmable filter
- 71 - FTV with programmable filter

73 - M83723 bayonet coupling with VHF-1 filter

75 - FSJT with programmable filter

76 - FTV with VHF-1 filter with composite shell

77 - FLJT with ± 8 volt diode/VHF-1 filter combination

78 - FTV PCB mount with standard flange

79 - M83723 (UTS) with bayonet mount

80 - FTV PCB mount with standard flange and standard nut

82 - FTV with ± 8 volt diode/VHF-1 filter combination

83 - FSJT with ± 8 volt diode/VHF-1 filter combination

84 - FTV (UTS) with ± 8 volt diode only

85 - FBL with ± 8 volt/VHF-1 filter combination

87 - FLJT (UTS) with ± 8 volt diode/VHF-1 filter combination

96 - FPT-E (UTS) with 3-8 Nfd Pi 1500V filter

9 Shell Finishes

- 0 - chromate
- 1 - bright cadmium
- 2 - stainless steel (electrolytic nickel plated)
- 4 - electroless nickel, MS (F)
- 5 - gold plate over nickel
- 7 - cadmium plate over nickel, MS (A)
- 8 - bright nickel
- 9 - cadmium plate, nickel base, OD, MS(B), (500 hr. salt spray test)

2 Shell Styles

- 0 - wall mount receptacle
- 2 - box mount receptacle
- 3 - jam nut receptacle with rear thread (PT only)
- 4 - minimum penetration jam nut receptacle
- 7 - jam nut receptacle

16 Shell Size

- 8 through 24 - FJT and FPT shell sizes available
- 9 through 25 - FLJT and FTV shell sizes available

26 Insert Arrangement

Refer to corresponding Mil-Spec.

P Type of Contact and Insert Arrangement

- P - pins in a normal rotation
 - S - sockets in a normal rotation
- For alternate rotations go to the table below for suffix letter.

ALTERNATE ROTATION SUFFIX LETTERS

FJT, FLJT or FSJT			FTV or FCTV			FPT			FBL Series IV			FAN		
Alternate Position	Suffix Letter		Alternate Position	Suffix Letter		Alternate Position	Suffix Letter		Alternate Position	Suffix Letter		Alternate Position	Suffix Letter	
	Pins	Sockets		Pins	Sockets		Pins	Sockets		Pins	Sockets		Pins	Sockets
Normal	P	S	Normal	P	S	Normal	P	S	N	P	S	Normal	P	S
A	E	F	A	G	H	W	G	H	A	E	F	W	G	H
B	R	T	B	I	J	X	I	J	B	G	H	X	I	J
C	W	X	C	K	L	Y	K	L	C	J	L	Y	K	L
D	Y	Z	D	M	N	Z	M	N	D	R	T	Z	M	N
			E	R	T				K	W	X	12	C	D
												13	A	B

How to Order

EMI filter check list

Date _____

Ref. Filter P/N _____ Ref. Mil-Spec _____

Filter Requirements:

Filter Type (Pi, C, LC, T, LL, other) _____

Capacitance (locations) _____

Capacitance (locations) _____

Frequency (MHz)	Insertion Loss (dB)
1	
3	
10	
30	
100	

Working Voltage (VDC or VAC and frequency) _____

Dielectric Withstand Voltage (VDC) _____

Filter Contacts (locations) _____

Ground Contacts (locations) _____

Insulated feed-thru (locations) _____

Modified Shell: (Flange moved, clinch nuts, heilicoils, stand offs, etc.) _____

Special Requirements: (AC voltage, spike voltage, attenuation testing, thermal cycling, burn-in, capacitor lot traceability, water immersion, etc.) _____

Contact Termination:

UTS _____

Solder Cup _____

Wire Wrap Flat dim. _____

Stickout dim. _____

PCB tail:

Diameter dim. _____

Stickout dim. _____

Pre-tin? _____

What is terminated to connector (ie. flex, rigid flex, PCB, etc.)? _____

Special Cleaning _____

(if so, recommend a protective cap with an environmental gasket)

Special Stamping: _____

Customer: _____

Program: _____

Forecast: _____

Requested by: _____

Comments: _____

Rectangular Filter Connectors

from Amphenol Canada

Amphenol Filtered Rectangulars

In addition to the filter interconnection products shown in this catalog, there is a wide range of filter products from Amphenol Canada which include:

- Micro D
- D-Sub
- Rectangular 38999
- M83733 Style
- ARINC 404 and ARINC 600
- Custom Rectangular Filter Designs

Some products and ordering information are shown here and on page 75. Please contact Amphenol Canada for any further information and for order placement.

Amphenol Canada
 20 Melford Drive
 Scarborough, ON M1B 2X6 Canada
 Phone: 416-291-4401
 Fax: 416-292-0647
 Website: www.amphenolcanada.com

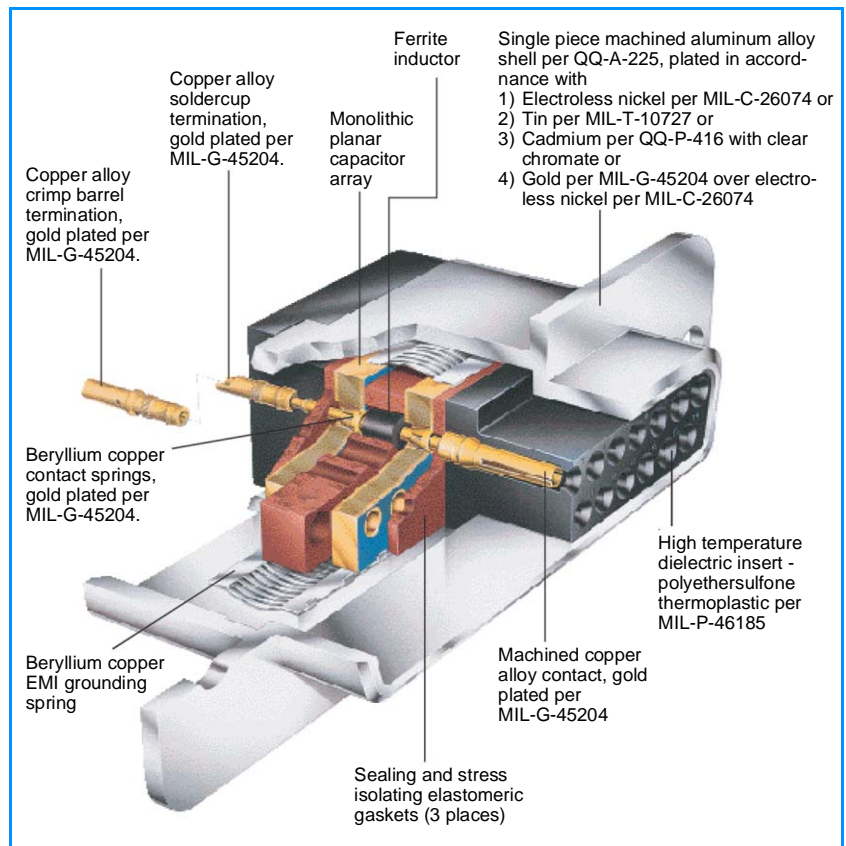

Micro-D Filter (M83513 Style)

Rack and panel mounting connectors for applications where space and weight are at a premium. For panel mount, cable mount and PCB mounting.

Example part number M13-21S3CA211-000 is shown:

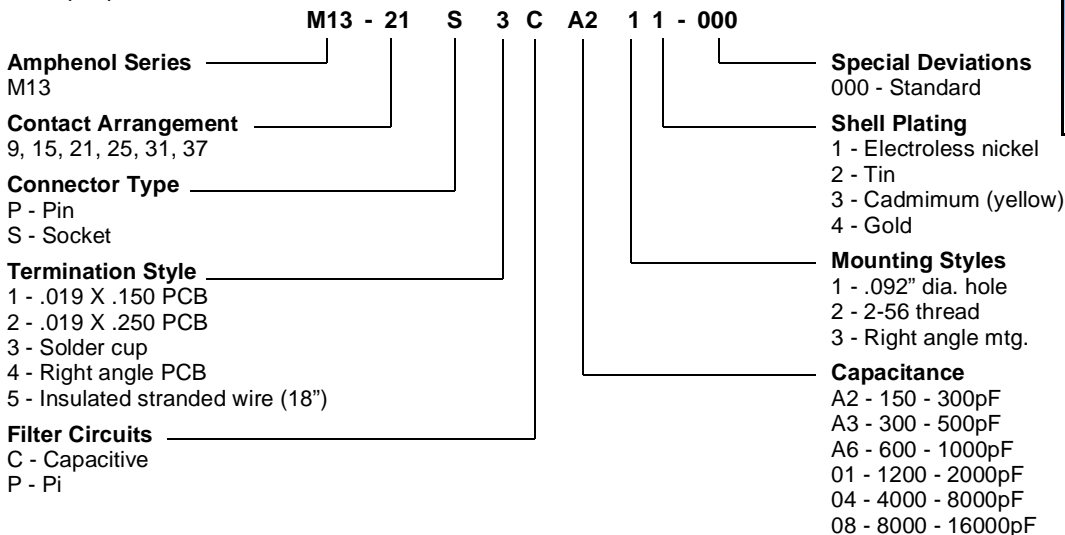

Rectangular Filter Connectors

from Amphenol Canada, cont.

D-Sub Filter (M24308 Style)

EMI Filtered D-Sub connectors designed for aerospace, industrial and commercial applications, using planar capacitors for high reliability.

Example part number 308-BP1P08111-000H is shown:

308 - B P 1 P 08 1 1 - 000 H

<p>Amphenol Series _____ Planar D-Sub</p> <p>Shell Size _____ E(1), A(2), B(3), C(4) D(5), 6</p> <p>Connector Type _____ P - Pin S - Socket</p> <p>Termination Style _____ 1, 2 - Vertical PCB 3 - Solder cup 4, 5, 6, 7 - Right angle PCB 9 - Crimp, non-removable contacts</p> <p>Filter Circuits _____ P = Pi C = Capacitive R = CLR T = T Style L = LRC</p>	<p>Density H - High density Blank if medium density</p> <p>Deviation 000 = Standard</p> <p>Shell Plating 1 - Electroless nickel 4 - Gold 2 - Tin 5 - Zinc nickel 3 - Cadmium (clear)</p> <p>Mounting Style 1 - .120" (3.04mm) mounting hole 2 - 4-40 Threaded cinch nut 3 - Right angle mounting bracket 4 - Right angle mounting bracket with 4-40 threaded cinch nut</p> <p>Capacitance (PF) Pi, C, CRL, LRC, T A2 = 200 to 400 04 = 4000 to 8000 A4 = 400 to 800 08 = 8000 to 16000 02 = 1800 to 3600 16 = 16000 to 32000</p>
--	--



458 Filtered (83733) & F39 Filtered (R39)

458 Series filter rack and panel connectors offer the cost advantages of planar ceramic technology in conjunction with stress isolation techniques. F39 filter connectors provide the same advantages in custom rectangular connectors using 38999 Series II contacts.

Example part number 458-A131P-TCA1-XXX is shown:

458 - A 131 P - T CA1 - XXX

<p>Amphenol Series _____ 458 for Filtered 83733 F39 for Filtered R39</p> <p>Shell Size _____</p> <p>Insert _____</p> <p>Pin/Socket _____</p>	<p>000 XXX for specials</p> <p>Filter Style CA2, C01, C02, C10, PA4, P02, P04, P08, P1</p> <p>Termination Styles S = Solder Cup B = PCB T = Crimp</p>
--	---



ARINC Filter (404 & 600)

Rack and panel ARINC 404 connectors meet or exceed MIL-C-81659 and ARINC Spec. 404. ARINC 600 connectors is the successor to the 404 for many new avionic designs.

Example part number F85-6RB2A150B121C13W2P02X is shown:

F85 - 6 R B 2 A150B121C13W2 P 02 X

<p>Amphenol Series _____ 485 is Production part designation F85 is Catalog/Website description only</p> <p>ARINC Series _____ 4 = ARINC 404 or MIL-C-81659 6 = ARINC 600</p> <p>Style _____ A = Adapter P = Plug R = Receptacle</p> <p>Termination _____ B = PC Tails S = Solder Cup</p> <p>Shell Size _____ A, B (ARINC 404) 1, 2, 3 or 4</p>	<p>Deviation</p> <p>Capacitance Same as 308 Series</p> <p>Filter Circuit P = Pi C = Capacitance</p> <p>Layout Designator ARINC 600 Define inserts for each cavity Define inserts and gender (P or S) ARINC 404 for each cavity (e.g. 106P)</p>
--	--

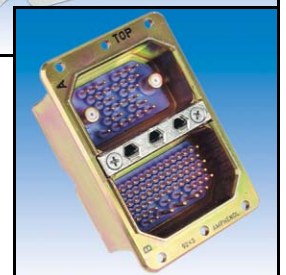

Amphenol[®] EMI/Transient Protection specials

The Hermetic Filter Connector

While only approximately 1/2 inch longer than standard series connectors, the hermetic filter connector provides all the benefits of a hermetic connector, as well as EMI protection for sensitive circuits. The filter assembly is protected by a fused glass insert within a unique steel housing. This design accounts for the connector's capability in tolerating high level static pressure, while maintaining a low level leakage rate. Applications include pressurized test equipment, environmental and toxic gas chambers, and moisture sealing on industrial equipment and missiles.



Filtered Plug



Hermetic Filter Connector

Filtered Plug

This connector is designed for applications where EMI protection is essential, but access to the receptacle is denied. The filtered plug presents an alternative for the electrical engineer. The filter plug is designed with the same components as a standard filter receptacle, but offers the option of being mounted on the cable harness. This device is a cost effective method of achieving EMI protection when length restrictions prohibit inclusion of an adapter to the system.

Filter Connectors can also incorporate high frequency coax, twinax, triax, quadax and differential twinax contacts.

Amphenol MIL-DTL-38999 Series III connectors are the most commonly used connectors for incorporation of shielded contacts along with traditional crimp contacts. High performance shielded coaxial, twinax and triax contacts are available to fit various RG and special cables. They eliminate discontinuities or impedance variations due to movement of parts under axial load. Size 8 quadax and differential twinax contacts provide high speed data transfers.



Filter Connectors with Coax Shielded Contacts

Filter Connectors with Flex Termination

Flex circuits are available for MIL-DTL-38999, MIL-DTL-5015 and MIL-C-26482 filter connectors. They are offered in flat or sculptured styles and provide flexibility in assembling to printed circuit boards.

Through Amphenol's Advanced Circuit Technology division, these strong and rigid, yet highly flexible circuits eliminate the need to purchase and attach individual pins or connectors. Thus they promote system automation, reduce space requirements and lower installation costs. Sculptured[®] Flexible Circuits have built-in terminations which eliminate the failure associated with crimped or soldered-on contacts, and geometrically fit the tight space requirements within a unit.

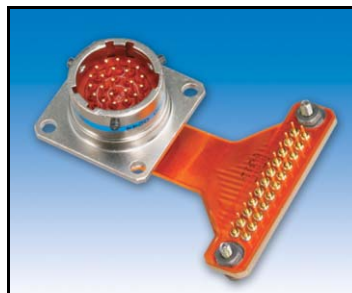

Flex Circuitry for Attachment to Printed Circuit Boards



MIL-DTL-38999 with Quadax Contacts

For more information on these specials, consult Amphenol Aerospace and see our website at www.amphenol-aerospace.com.