



Series 801 Mighty Mouse Double-Start ACME Threads Crimp Receptacle Connector Ordering Information
801-009 and 801-010



In-Line
Shell Style 01



Rear Panel Jam Nut Mount
Shell Style 07



Square Flange Mount
Shell Style 02

HOW TO ORDER

Sample Part Number

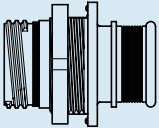
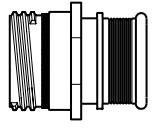
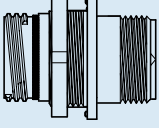
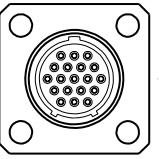
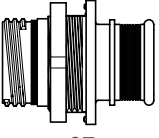
801-010	-02	Z1	16-55	S	A
Series	Shell Style	Shell Material / Finish	Shell Size- Insert Arrangement	Contact Type	Shell Key Position
 801-009 Receptacle with Banding Platform	 -01 In-Line For Free-Hanging Cables	C Aluminum / Black Anodize (Non-Conductive) RoHS Compliant M Aluminum / Electroless Nickel RoHS Compliant NF Aluminum / Cadmium with Olive Drab Chromate ZN Aluminum / Zinc-Nickel with Olive Drab Chromate ZNU Aluminum / Zinc-Nickel with Black Chromate MT Aluminum / Nickel-PTFE RoHS Compliant Z1 Stainless Steel / Passivated RoHS Compliant	SEE CONTACT ARRANGEMENTS PAGE D-2	Connector supplied with contacts P Pin S Socket Connector supplied without contacts A Pin B Socket Connector Connectors with contacts are supplied with signal and/or power crimp contacts. These contacts are not installed. Coaxial contacts and non-standard signal contacts are ordered separately.	A Normal Alternate Key Positions: B C D E F
 801-010 Receptacle with Accessory Thread	 -02 Square Flange For Front or Rear Mounting	(Same as above)	(Same as above)	(Same as above)	(Same as above)
	 -07 Jam Nut For Rear Panel Mounting	(Same as above)	(Same as above)	(Same as above)	(Same as above)

Dimensions in inches (millimeters) and are subject to change without notice.

© 2010 Glenair, Inc.

CAGE Code 06324

Printed in U.S.A.

GLENAIR, INC. • 1211 AIR WAY • GLENDALE, CA 91201-2497 • 818-247-6000 • FAX 818-500-9912

www.glenair.com

D-8

E-Mail: sales@glenair.com

01-JANUARY-2010

Series 801 Mighty Mouse Double-Start ACME Threads Jam Nut Receptacle Connector Dimensions

801-009-07 and 801-010-07

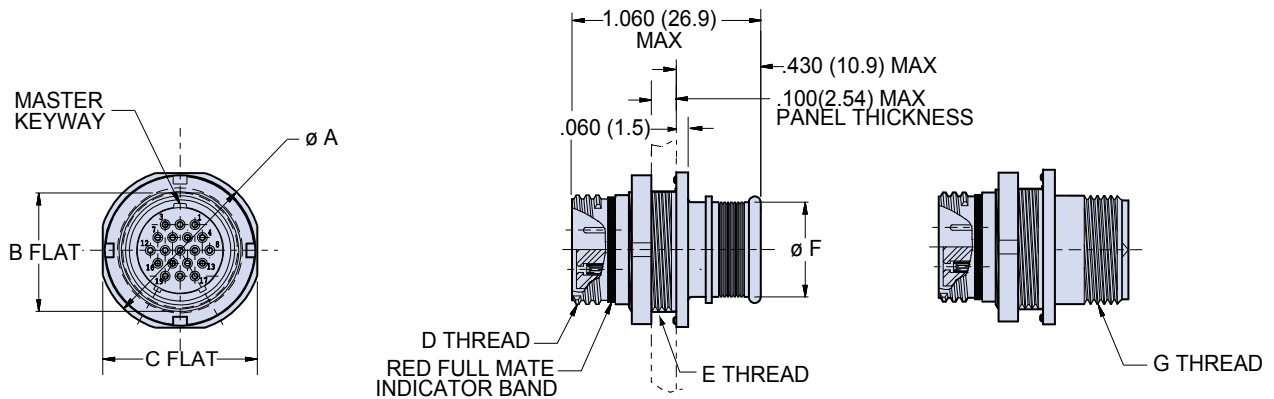

Integral Band Platform
801-009-07

Accessory Thread
801-010-07

D

DIMENSIONS											
Shell Size	Ø A		B Flat		C Flat		D Thread	E Thread UN-2A	Ø F		G Thread UN-2A
	In.	mm.	In.	mm.	In.	mm.			In.	mm.	
5	.575	14.61	.350	8.89	.545	13.84	.3125-.05P-.1L-2A	.375-28	.245	6.22	.250-32
6	.635	16.13	.410	10.41	.595	15.11	.375-.05P-.1L-2A	.4375-28	.290	7.37	.3125-32
7	.755	19.18	.536	13.61	.723	18.36	.4375-.05P-.1L-2A	.5625-32	.390	9.91	.4375-28
8	.755	19.77	.536	13.61	.723	18.36	.5000-.05P-.1L-2A	.5625-32	.445	11.30	.5000-28
9	.830	21.08	.596	15.14	.790	20.07	.5625-.05P-.1L-2A	.625-28	.500	12.70	.5625-24
10	.890	22.61	.658	16.71	.855	21.72	.6250-.05P-.1L-2A	.6875-28	.560	14.22	.6250-24
13	1.078	27.38	.845	21.46	1.044	26.52	.8125-.1P-.2L-2A	.875-28	.650	16.51	.6875-24
16	1.264	32.11	1.022	25.96	1.230	31.24	1.000-.1P-.2L-2A	1.0625-20	.805	20.45	.9375-20
17	1.325	33.66	1.096	27.84	1.290	32.77	1.062-.1P-.2L-2A	1.125-28	.850	21.59	.9375-20
21	1.625	41.28	1.345	34.16	1.577	40.06	1.3125-.1P-.2L-2A	1.375-28	1.110	28.19	1.1875-18

KEY POSITIONS

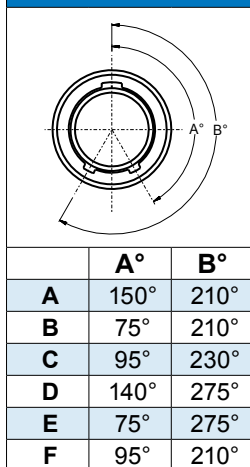

SERIES 801 JAM NUT PANEL CUTOUT

Shell Size	A Flat		Ø B	
	In. ± .002	mm. ± 0.05	In. ± .002	mm. ± 0.05
5	.356	9.04	.385	9.78
6	.416	10.57	.447	11.35
7	.542	13.77	.572	14.53
8	.542	13.77	.572	14.53
9	.602	15.29	.635	16.13
10	.666	16.92	.697	17.70
13	.851	21.62	.885	22.48
16	1.028	26.11	1.075	27.31
17	1.102	27.99	1.135	28.83
21	1.354	34.39	1.385	35.18

Dimensions in inches (millimeters) and are subject to change without notice.

Series 801 Mighty Mouse Double-Start ACME Threads Square Flange Receptacle Connector Dimensions

801-009-02 and 801-010-02

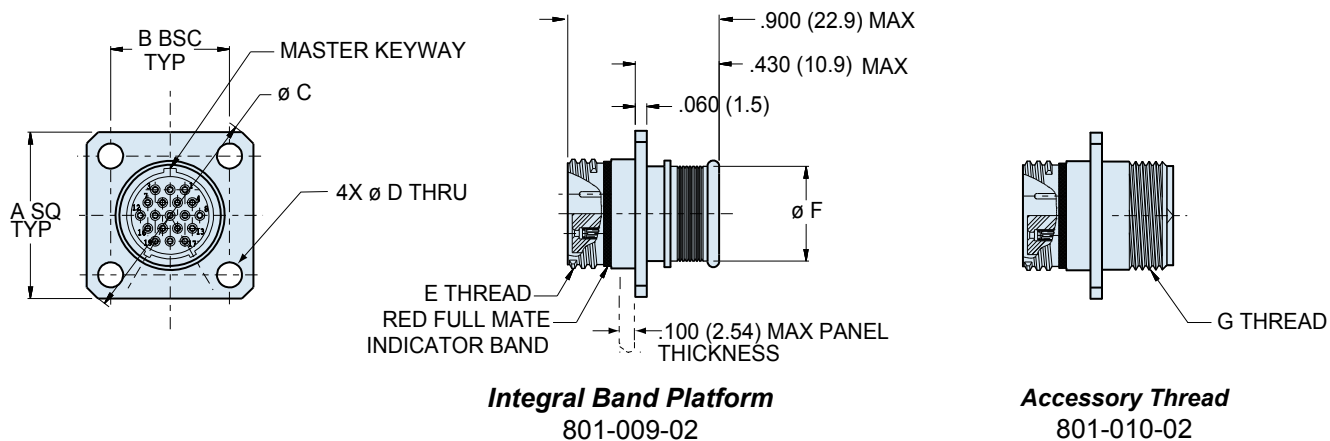

DIMENSIONS

Shell Size	A		B BSC		Ø C		Ø D		E Thread	Ø F		G Thread UNEF-2A
	In.	mm.	In.	mm.	In.	mm.	±.003 ±.08			In.	mm.	
							In.	mm.				
5	.530	13.46	.363	9.22	.680	17.27	.093	2.36	.3125-.05P-.1L-2A	.245	6.22	.250-32
6	.590	14.99	.423	10.74	.750	19.05	.093	2.36	.375-.05P-.1L-2A	.290	7.37	.3125-32
7	.650	16.51	.483	12.27	.850	21.59	.093	2.36	.4375-.05P-.1L-2A	.390	9.91	.4375-28
8	.712	18.08	.545	13.84	.938	23.83	.093	2.36	.5000-.05P-.1L-2A	.445	11.30	.5000-28
9	.850	21.59	.607	15.42	1.125	28.58	.128	3.25	.5625-.05P-.1L-2A	.500	12.70	.5625-24
10	.890	22.61	.670	17.02	1.188	30.18	.128	2.25	.6250-.05P-.1L-2A	.560	14.22	.6250-24
13	1.030	26.16	.812	20.62	1.375	34.93	.128	3.25	.8125-.1P-.2L-2A	.650	16.51	.6875-24
16	1.219	30.96	.981	24.92	1.625	41.28	.128	3.25	1.000-.1P-.2L-2A	.805	20.45	.9375-20
17	1.280	32.51	1.060	26.92	1.700	43.18	.128	3.25	1.062-.1P-.2L-2A	.850	21.59	.9375-20
21	1.430	36.32	1.205	30.61	1.938	49.23	.128	3.25	1.3125-.1P-.2L-2A	1.110	28.19	1.1875-18

SERIES 801 PANEL CUTOUT

Shell Size	Ø A		Ø B		Ø C	
	In.	mm.	In.	mm.	In.	mm.
	5	.330	8.38	.363	9.22	.093
6	.390	9.91	.423	10.74	.093	2.36
7	.450	11.43	.483	12.27	.093	2.36
8	.510	12.95	.545	13.84	.093	2.36
9	.575	14.61	.607	15.42	.128	3.25
10	.640	16.26	.670	17.02	.128	3.25
13	.825	20.96	.812	20.65	.128	3.25
16	1.015	25.78	.981	24.92	.128	3.25
17	1.075	27.31	1.060	26.92	.128	3.25
21	1.325	33.66	1.205	30.61	.128	3.25

KEY POSITIONS

	A°	B°
A	150°	210°
B	75°	210°
C	95°	230°
D	140°	275°
E	75°	275°
F	95°	210°

Dimensions in inches (millimeters) and are subject to change without notice.

© 2010 Glenair, Inc.

CAGE Code 06324

Printed in U.S.A.

GLENAIR, INC. • 1211 AIR WAY • GLENDALE, CA 91201-2497 • 818-247-6000 • FAX 818-500-9912

www.glenair.com

D-10

E-Mail: sales@glenair.com

01-JANUARY-2010

Series 801 Mighty Mouse Double-Start ACME Threads In-Line Receptacle Connector Dimensions

801-009-01 and 801-010-01

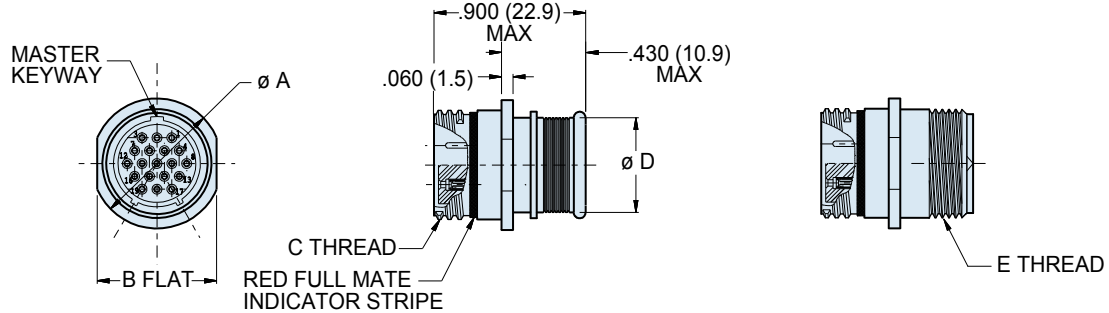

Integral Band Platform
801-009-01

Accessory Thread
801-010-01

DIMENSIONS

Shell Size	Ø A		B Flat		C Thread	Ø D		E Thread UNEF-2A
	In.	mm.	In.	mm.		In.	mm.	
5	.355	9.02	.325	8.13	.3125-.05P-.1L-2A	.245	6.22	.250-32
6	.415	10.54	.385	9.78	.375-.05P-.1L-2A	.290	7.37	.3125-32
7	.480	12.19	.445	11.30	.4375-.05P-1L2A	.390	9.91	.4375-28
8	.540	13.72	.510	12.95	.5000-.05P-1L2A	.445	11.30	.5000-28
9	.605	15.37	.575	14.61	.5625-.05P-.1L-2A	.500	12.70	.5625-24
10	.665	16.89	.635	16.13	.6250-.05P-1L2A	.560	14.22	.6250-24
13	.855	21.72	.825	20.96	.8125-.1P-.2L-2a	.650	16.51	.6875-24
16	1.040	26.42	1.010	25.65	1.000-.1P-.2L-2A	.805	20.44	.9375-20
17	1.110	28.19	1.070	27.18	1.062-.1P-.2L-2A	.850	21.59	.9375-20
21	1.405	35.69	1.385	35.18	1.3125-.1P-.2L-2A	1.110	28.19	1.1875-18

KEY POSITIONS

	A°	B°
A	150°	210°
B	75°	210°
C	95°	230°
D	140°	275°
E	75°	275°
F	95°	210°

Dimensions in inches (millimeters) and are subject to change without notice.

© 2010 Glenair, Inc.

CAGE Code 06324

Printed in U.S.A.

GLENAIR, INC. • 1211 AIR WAY • GLENDALE, CA 91201-2497 • 818-247-6000 • FAX 818-500-9912

www.glenair.com

D-11

E-Mail: sales@glenair.com

01-JANUARY-2010