

**NUT OPTIONS**

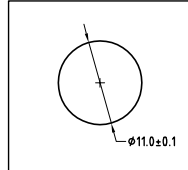

**PANEL CUTOUT**

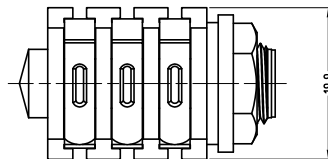
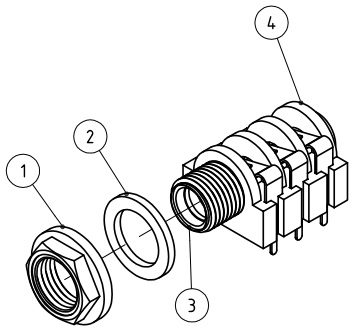
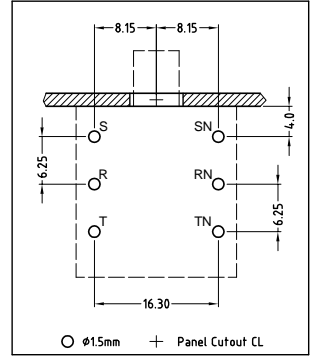

**PCB LAYOUT**

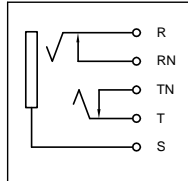

**SCHEMATIC**

| ITEM | DESCRIPTION        |
|------|--------------------|
| 1    | METAL/PLASTIC NUT  |
| 2    | FIBRE WASHER       |
| 3    | METAL TUBE INSERT  |
| 4    | CONNECTOR ASSEMBLY |

| PART No.     | CATALOG No. | DESCRIPTION |
|--------------|-------------|-------------|
| 55010099-000 | ACJS-MH     | METAL NUT   |
| 55010099-001 | ACJS-PH     | PLASTIC NUT |

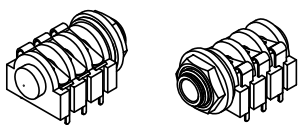

**ISO VIEW**

|  |              |   |  |   |                |                                 |          |      |
|--|--------------|---|--|---|----------------|---------------------------------|----------|------|
| UNLESS OTHERWISE SPECIFIED TOLERANCE TO BE |              | THIS DOCUMENT IS THE PROPERTY OF AMPHENOL AUSTRALIA PTY. LTD. NO PART THEREOF MAY BE REPRODUCED AND USED WITHOUT THE PRIOR WRITTEN CONSENT OF THE OWNER |  | 1 CHANGE DRAWING NUMBER & PART VARIATION NUMBER |                | L.V                             | 07-07-04 | 8293 |
| LINEAR                                     |              | ANGULAR   |  | 0 FIRST ISSUE                                   |                | L.V                             | 17-10-01 | ---- |
| X ± 0.5                                    | X° ± 1'      | CAD FILE: 55010099000111  |  | DRN: L.V  | DATE: 17-10-01 | REV. CHANGE DETAILS             |          |      |
| X.X ± 0.1                                  | X°X' ± 30"   | MATERIAL: REFER TO COMPONENT  |  | CKD: M.N.H                                      | DATE: 13-01-06 | TITLE: 1/4" STEREO JACK PCB LUG |          |      |
| X.XX ± 0.05                                | X°X'X" ± 15" | FINISH: REFER TO COMPONENT  |  | APP'D: P.M                                      | DATE: 13-01-06 | CUSTOMER DRAWING                |          |      |
| DO NOT SCALE                               |              | SCALE: 2:1 UOS  |  | PART No: REFER TO TABLE                         |                | DRAWING NO. 55010099-000-1      |          |      |
| DIMENSIONS IN MILLIMETRES                  |              | THIRD ANGLE PROJECTION  |  | SIZE: A3  |                | SHEET 1 OF 1                    |          |      |

