

3D VIEW

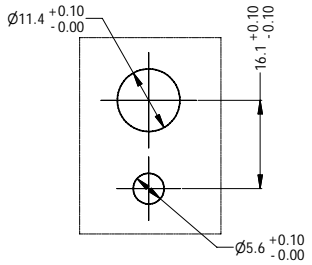

PANEL CUTOUT
(SCALE 1:1)

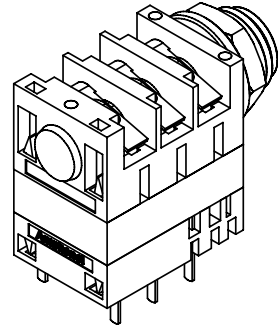
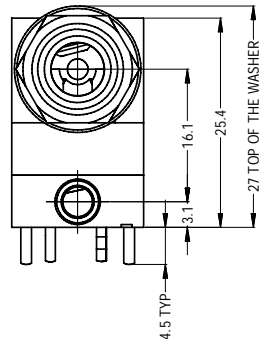
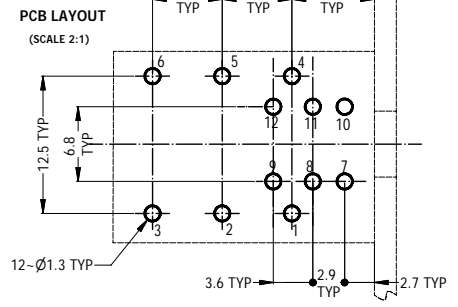
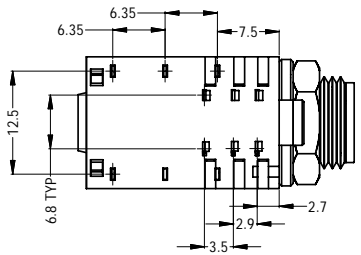
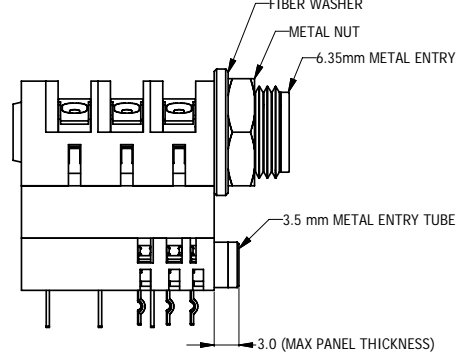
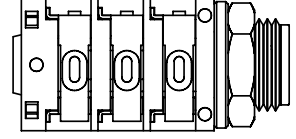
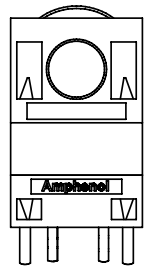

ACJS-MHD985	3.5mm & 1/4" STEREO PHONE DUAL JACK - METAL NUT
ACJM-MHD985	3.5mm & 1/4" MONO PHONE DUAL JACK - METAL NUT
ACJS-PHD985	3.5mm & 1/4" STEREO PHONE DUAL JACK - PLASTIC NUT
ACJM-PHD985	3.5mm & 1/4" MONO PHONE DUAL JACK - PLASTIC NUT
PART NUMBER	DESCRIPTION

UNLESS OTHERWISE SPECIFIED TOLERANCES TO BE		THIS DOCUMENT IS THE PROPERTY OF AMPHENOL AUSTRALIA PTY. LTD. NO PART THEREOF MAY BE REPRODUCED AND USED WITHOUT THE PRIOR WRITTEN CONSENT OF THE OWNER			
LINEAR	ANGULAR	CAD FILE:	DRN:	DATE:	
X ± 0.5 X.X ± 0.25 X.XX ± 0.10	X° ± 1 X.X° ± 30° X.XX° ± 15°	55010386000110	T.N	28/09/06	
BREAK ALL SHARP EDGES AND REMOVE ALL BURRS		MATL:	CKD:	DATE:	
DO NOT SCALE		REFER TO COMPONENT	M.H	24/01/11	
DIMENSIONS IN MILLIMETRES		FINISH:	APP'D:	DATE:	
		REFER TO COMPONENT	P.M	24/01/11	
		THIRD ANGLE PROJECTION	SCALE:	PART No:	
			3:2		

0	FIRST ISSUED	M.H	09/02/09	8798
1	CORRECT PCB PROFILE FROM STRAIGHT TO RETAINER STYLE, REF LOCATION 4D	M.H	24/01/2011	8978
REV	DESCRIPTION	BY	DATE	CHG NOTE
REVISION HISTORY				
TITLE:		Amphenol		
6.35mm & 3.5mm HORIZONTAL DUAL JACK		Amphenol Australia Pty.Ltd, 2 Flieway Blvd, Keysborough, VIC3173		
DRAWING NO.		SHEET		
SEE TABLE		55010386-001-1 1/1		
SIZE: A4				