

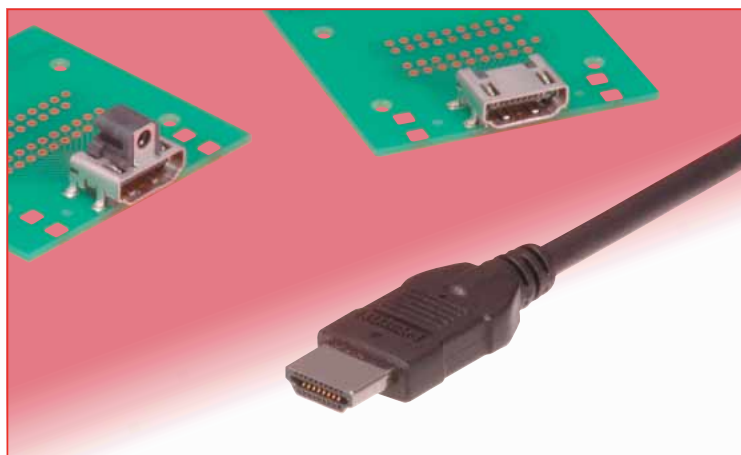

HDMI™ Standard Connectors

MD Series



Features

1. Two panel mounting styles (receptacle)

- SMT termination, through panel (no screw)
- SMT termination, through panel, single screw panel attachment

2. Easy insertion

Mating interface is visible on the panel surface, allowing correct insertion of the plug. (Figures (1) and (2))

3. Reliable connection

Fully mated condition between the plug and receptacle is confirmed with a distinctive tactile "click" sensation, assuring complete mechanical and electrical connection.

4. Small size

Despite it's small size, solder connection of the wires to the terminations is easily performed.

5. Strong shields

Two-piece shields surrounding the wire termination areas provide EMI protection as well as increase the strength of the plug. (Figure (3))

6. RoHS compliant

All components and materials comply with the requirements of EU Directive 2002/95/EC

Applications

PDP, LCD, CRT televisions, projectors, DVD, set top boxes and other audio-visual peripheral equipment.

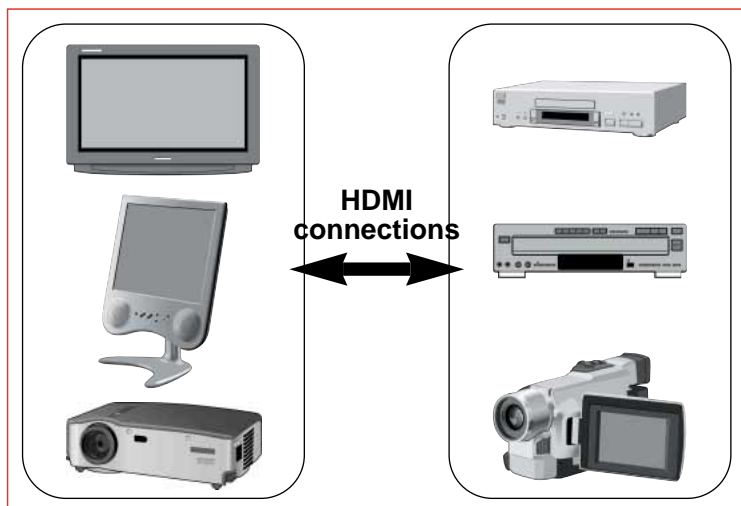

*High Definition Multimedia Interface and HDMI are trademarks of HDMI Licensing, LLC.

Overview

Connectors conforming to the requirements of the High Definition Multimedia Interface (HDMI) Standard intended for the digital television.

The HDMI places the video and audio links into a single connector /cable.

1.6 mm offset from the mating surface

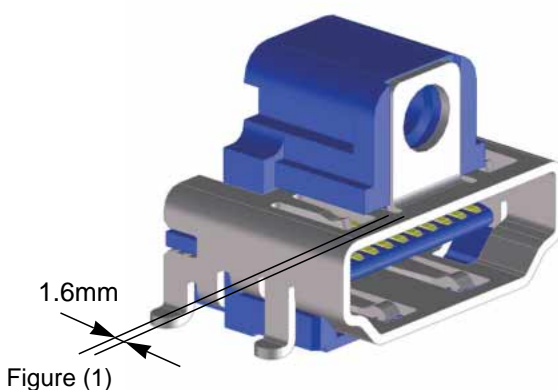

Easy insertion - connector flush with the panel

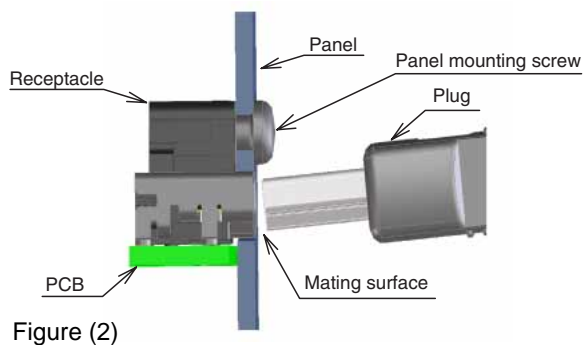

Strong shields-plug

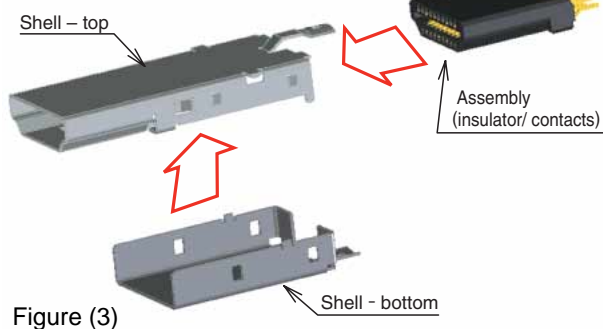

MD Series ● HDMI Standard Connectors

■ Specifications

Ratings	Current rating	0.5A	Operating temperature range : -55°C to +85°C
	Voltage rating	125V AC	

Item	Specification	Conditions
1. Contact resistance	Signal: 60 mΩ max. Shell: 30 mΩ max.	100mA (DC or 1,000Hz)
2. Insulation resistance	100 MΩ min.	500V DC
3. Withstanding voltage	No flashover or insulation breakdown	500 V AC / 1 minute
4. Durability	Contact resistance of contacts: Change of 30mΩ max. Contact resistance of shell: Change of 50mΩ max.	10,000 cycles
5. Vibration	No electrical discontinuity of 1 μs or longer. Contact resistance, contacts: Change of 30 mΩ max.	Frequency: 55 to 2,000 Hz, total amplitude of 1.5 mm Acceleration of 147 m/s ² , 12 test cycles in each of the 3 directions
6. Shock	Contact resistance, shell: Change of 50 mΩ max. No damage, cracks, or parts dislocation	Acceleration of 490m/s ² , 11 ms continuous time, sine half-wave, 3 test cycles in each of the 3 directions
7. Temperature cycle	Contact resistance, contacts: Change of 30 mΩ max. Contact resistance, shell: Change of 50 mΩ max. No damage, cracks, or parts dislocation	Temperature:-55°C→+15°C to 35°C→+85°C→+15°C to 35°C Times: 30 min.→ 2 min.to 3 min. → 30 min.→ 2 min. to 3 min 10 cycles
8. Salt spray	No corrosion	5% salt water solution / 48 hours

■ Materials / Finishes

● Receptacles

Part	Material	Finish	Remarks
Insulator	LCP	—	UL94V-0
Contacts	Copper alloy	Contact area: Gold plating over nickel Lead area: Gold flash plating over nickel	— —
Shell	Copper alloy	Tin plating over nickel	—

● Plugs

Part	Material	Finish	Remarks
Insulator	LCP	—	UL94V-0
Contacts	Copper alloy	Contact area: Gold plating over nickel Lead area: Gold flash plating over nickel	— —
Shell	Copper alloy	Tin plating over nickel	—

■ Ordering information

● Receptacles

MD 60 - 19 P A

① ② ③ ④ ⑤

● Plugs

MD 40 - 19 S

① ② ③ ④

Receptacles

①	Series name	: MD
②	Board mounting style:	
	60	:Right angle SMT
③	Number of Contacts	:19
④	Contact type	
	P	: Male
⑤	Panel mounting style	
	Blank	:Standard
	A	:Single panel screw

Plugs

①	Series name	: MD
②	Termination style	
	40	: Solder
③	Number of Contacts	:19
④	Contact type	
	S	:Female

Note: Plug cable termination and overmold recommendations are available upon request.
 Contact your Hirose sales representative for details.

*Information contained in this catalog may not reflect latest updates.
 Request drawing for a specific part number listed.

Receptacles

Receptacles – Right angle

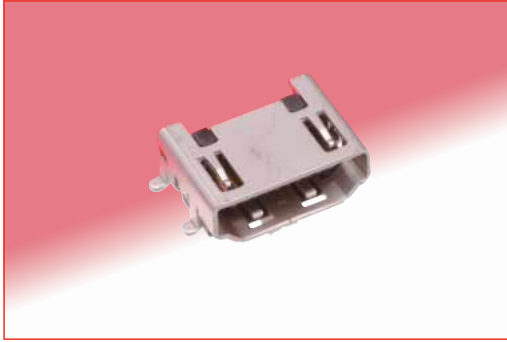

Part Number	CL No.	RoHS
MD60-19P	243-0001-8	YES

Note 1: Tape and reel packaging (750 pieces/reel).
Order by number of reels.

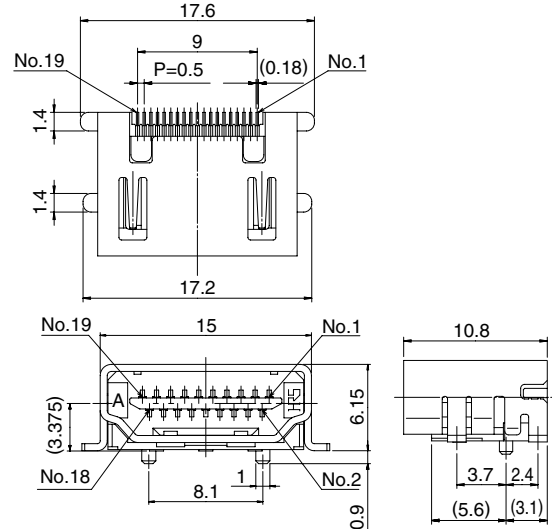

All dimensions: mm

Recommended Panel Cutout

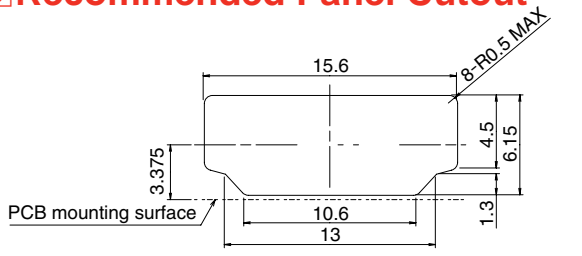

Recommended PCB mounting pattern

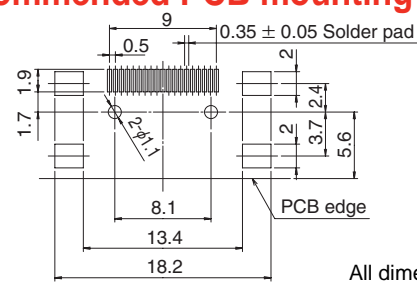

All dimensions: mm

Receptacles – Single panel screw

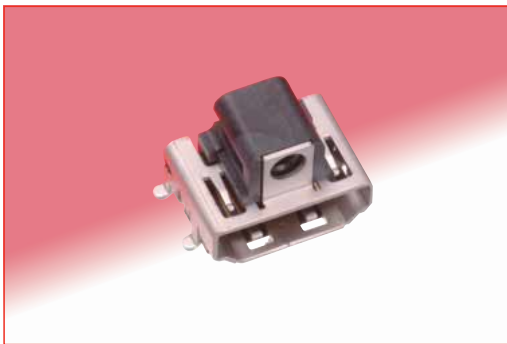

Part Number	CL No.	RoHS
MD60-19PA	243-0003-3	YES

Tray packaging

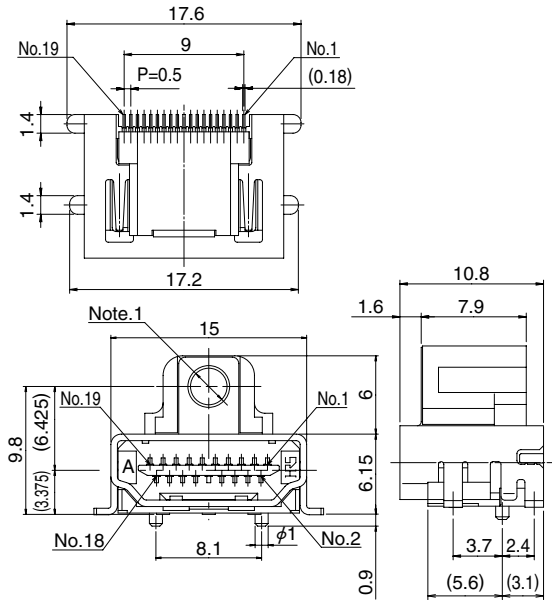

Note 1: Use M3x12mm long pan head self-taping screw.

Recommended Panel Cutout

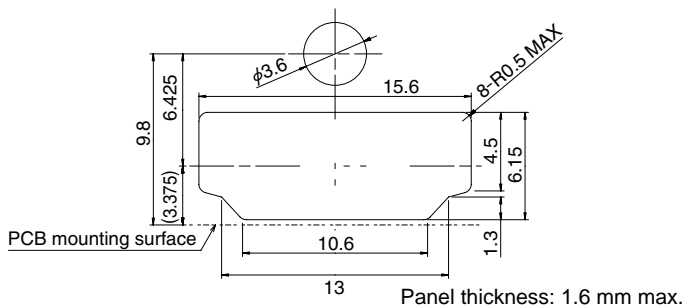

Recommended PCB mounting pattern

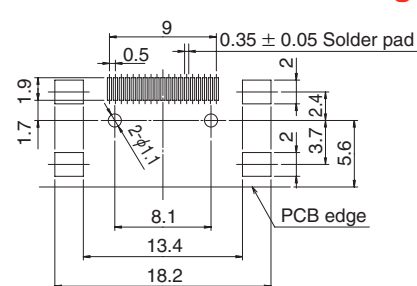

All dimensions: mm

■ Plug

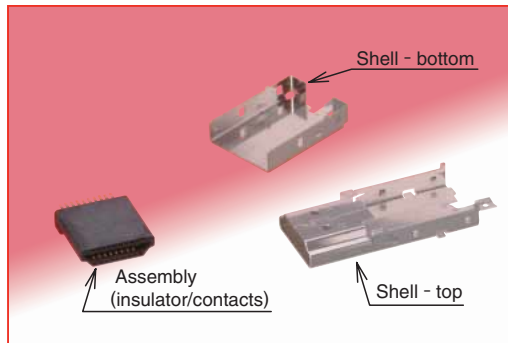

Part Number	CL No.	RoHS
MD40-19S	CL243-0002-0	YES

* Supplied separate as shown.

Assembly (insulator / contacts)

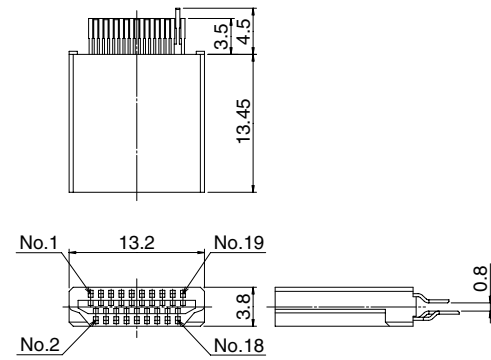

All dimensions: mm

Shell - top

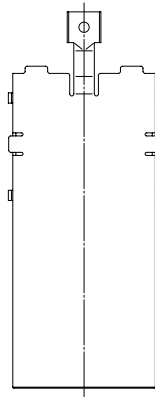
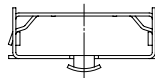

Shell- bottom

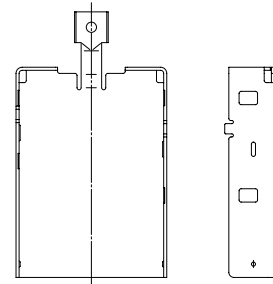
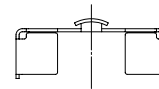

Note: Plug cable termination and overmold recommendations are available upon request.

Contact your Hirose sales representative for details.

■ Packaging Specifications

● Embossed carrier tape dimensions

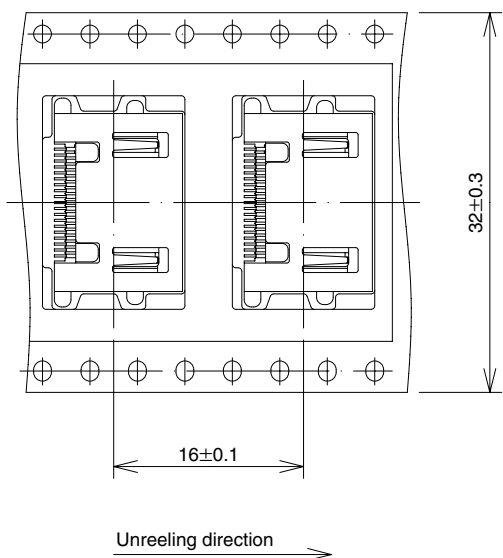

● Reel Dimensions

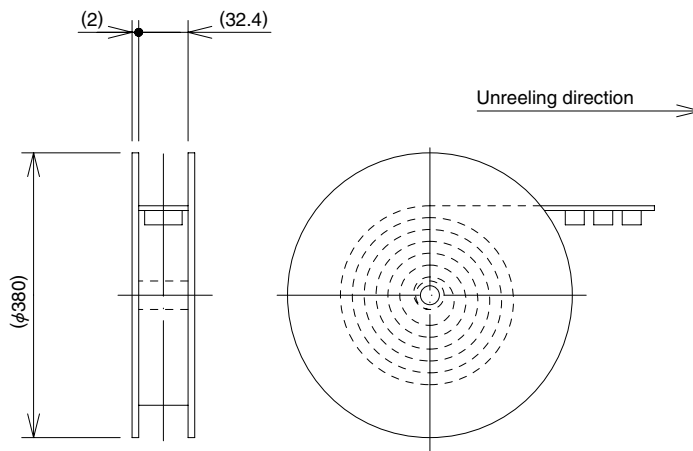

■ Recommended Temperature Profile

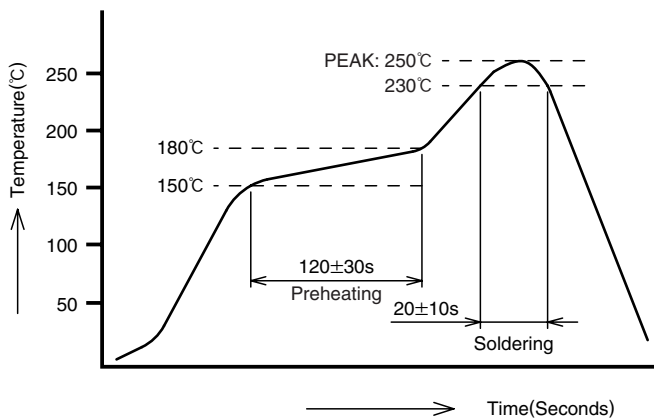

Note 1: Up to 2 cycles of Reflow soldering are possible under the same conditions, provided that there is a return to normal temperature between the first and second cycle.

Note 2: The temperature profile indicates the board surface temperature at the point of contacts with the connector terminals.



HIROSE ELECTRIC CO.,LTD.

5-23, OSAKI 5-CHOME, SHINAGAWA-KU, TOKYO 141-8587, JAPAN

PHONE: 81-3-3491-9741, FAX: 81-3-3493-2933

<http://www.hirose.com>

<http://www.hirose-connectors.com>