

FEATURES

- Carbon resistive element.
- Dust proof enclosure.
- With or without actuating knob
- Optional SPST switch

MECHANICAL SPECIFICATIONS

- Mechanical rotation angle: $255^\circ \pm 5^\circ$
- Electrical rotation angle: $220^\circ \pm 20^\circ$
- Torque: 0.5 to 1.5 Ncm.
(0.7 to 2.1 in-oz)
- Stop torque: > 40 Ncm. (> 56 in-oz)

ELECTRICAL SPECIFICATIONS

- Range of values (*)
 $100\Omega \leq R_n \leq 5\text{ M}$ (Decad. 1.0 - 2.0 - 2.2 - 2.5 - 4.7 - 5.0)
- Tolerance (*): $100\Omega \leq R_n \leq 1\text{M}\Omega$ $\pm 20\%$
 $1\text{M}\Omega < R_n \leq 5\text{M}\Omega$ $\pm 30\%$
- Max. Voltage: 200 VDC (lin) 100 VDC (no lin)
- Nominal Power 50°C (122°F) (see power rating curve)
0.25 W (lin) 0.12 W (no lin)
- Taper (*) (Log. & Alog. only $R_n > 1\text{K}$) Lin ; Log; Alog.
- Residual resistance(*): $\leq 0.5\%$ R_n (5 Ω min.)
- Equivalent Noise Resistance: $\leq 3\%$ R_n (3 Ω min.)
- Operating temperature**: $-25^\circ\text{C} + 70^\circ\text{C}$ ($-13^\circ\text{F} + 158^\circ\text{F}$)

* Others upon request

** Up to 85°C depending on application

HOW TO ORDER

STANDARD

Series	Terminals	Switch	Thumbwheel	Value	Taper	Tolerance
T-18	A = PCB B = Solder Lugs	I = with S = without	S = sb/st T = sb/ct 1 = Fig. 1 2 = Fig. 2 3 = Fig. 3 4 = Fig. 4 (See note 1)	10 1 = 100 Ω 20 3 = 20 K 50 4 = 500 K 50 5 = 5 M (See note 2)	A = Linear B = Log. C = Alog. (See note 4) Others tapers on request	2020 = +/-20% 3030 = +/-30% (See note 3)

NOTES:

- (1) Thumbwheel: S = without knob, without screw
T = without knob, with screw
Fig. 1, 2 y 3: countersunk knob
Fig. 4: knob with screw
knob colour: Black

If you wish to use your own custom plastic shaft/knob/actuator please contact Piher for advice about compatible materials.

- (2) Value: • Code: $\overbrace{10} \quad \overbrace{1} \quad 100\Omega$
Number of zeros
2 first digits of the value.
Others values upon request.

- (3) Tolerance (non standard), upon request.
Rotary switch with Alog. curve is not available.
(4) Switch option not available with antilog taper.

Example code: $+7 = \overbrace{07} \quad \overbrace{05}$
-5 \rightarrow negative tolerance
positive tolerance

NOTE: The information contained here should be used for reference purposes only.

HOW TO ORDER CUSTOM DRAWING

T-18 A | + DRAWING NUMBER (Max. 16 digits)

This way of ordering should be used for options which are not included in the "How to order" standard and optional extras.

TERMINALS

T-18 A

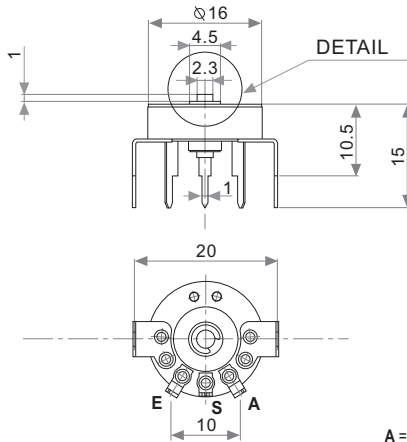

DETAIL

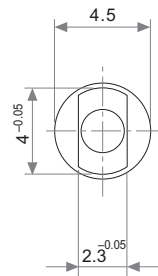

T-18 B

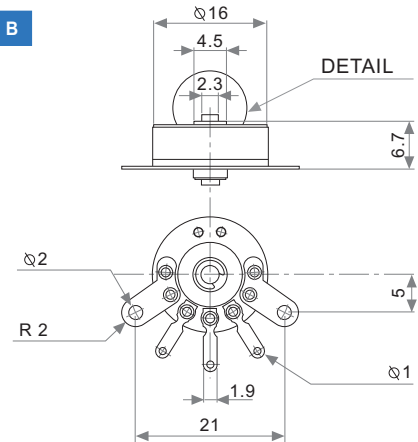

DETAIL

A = Initial S = Wiper E = Final

SWITCH

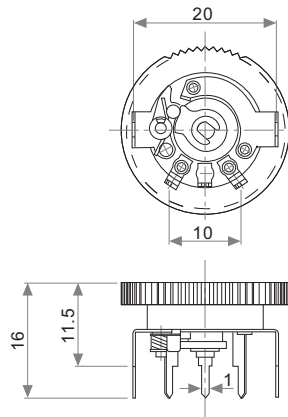

ELECTRICAL AND MECHANICAL	
SWITCH RATING	0.5 A; 12V DC
SWITCH OPERATING ANGLE	25° ± 10°
MECHANICAL LIFE (CYCLES)	10.000

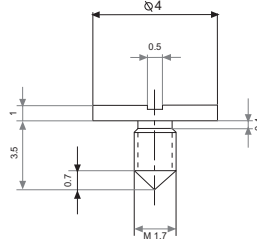

SCREW

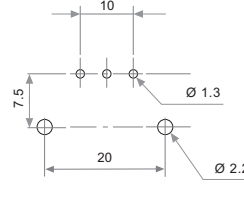

FOOTPRINT

POWER RATING CURVE

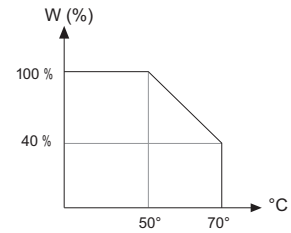

THUMBWHEEL

Fig. 1 / Ref. 5950

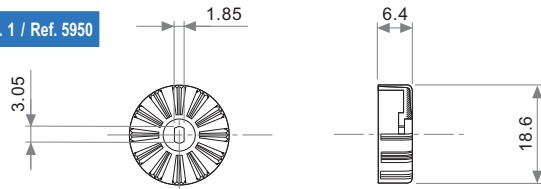

Fig. 2 / REF. 5951

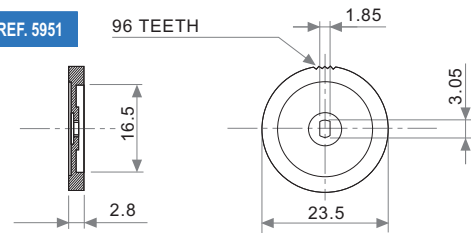

Fig. 3 / Ref. 5952

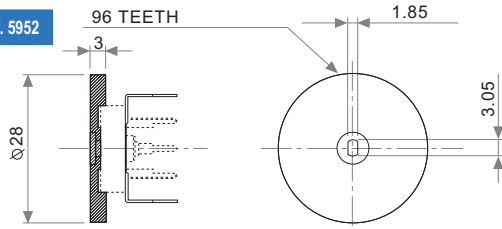
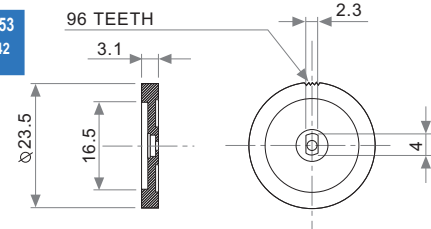

Fig. 4 / Ref. 5953
(Screw Ref. 5342 is required)



TESTS

TYPICAL VARIATIONS

ELECTRICAL LIFE	1.000 h. @ 50°C; 0.25 W	±5 %
MECHANICAL LIFE : POT.	25.000 (10-15 CPM)	±3 % (Rn < 1 M)
TEMPERATURE COEFFICIENT	-25 ° C; +70 ° C	±300 ppm (Rn < 100 K)
THERMAL CYCLING	16 h. @ 85 ° C; 2h @ -25 ° C	±2.5 %
DAMP HEAT	500 h. @ 40 ° C @ 95% HR	±5 %
VIBRATION (for each plane X,Y,Z)	2 h. @ 10 Hz - 55 Hz.	±2 %

NOTE: Out of range values may not comply these results.