

REV.	BY	DATE	PART NO.
B	AT	6-24-05	MD30
REVISE BRACKET AND DIMS.			

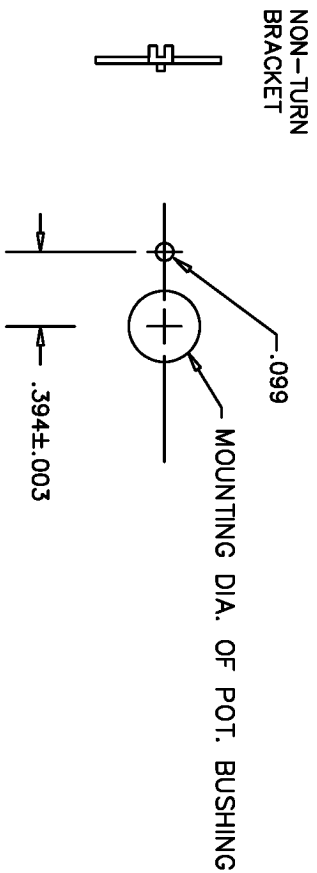
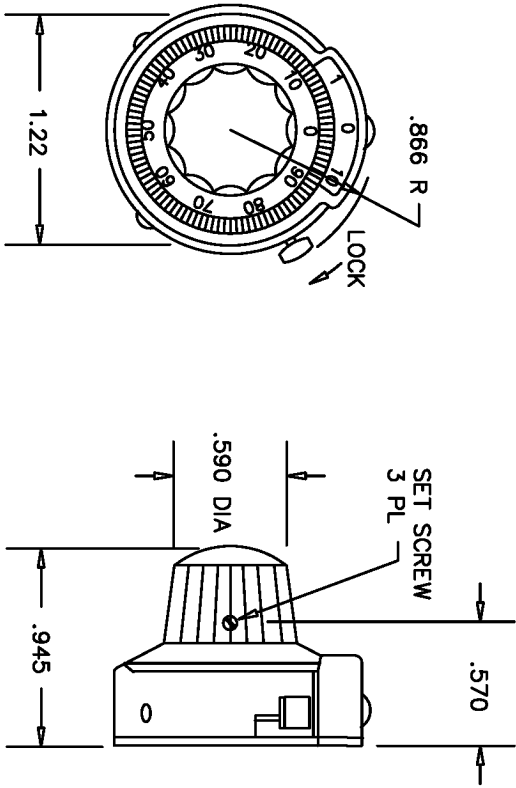

MODEL	MATCHING SHAFT SIZE	COLOR	LOCK
MD30L-1/8	1/8	BLACK (WHITE NUMBERS)	
MD30L-1/4	1/4	BLACK (WHITE NUMBERS)	YES
MD30L-6MM	6MM	BLACK (WHITE NUMBERS)	

SCALE	NONE
DATE:	10-13 88
BY	RJC

THIS DOCUMENT CONTAINS PROPRIETARY DATA OF POLARIS INDUSTRIAL ENTERPRISES, INC. NO DISCLOSURE, REPRODUCTION, OR USE OF ANY PART THERE OF MAY BE MADE EXCEPT BY WRITTEN PERMISSION.

<u>TOLERANCES</u>	
XX = +/- .010"	FRACT. = +/- 1/64"
XXX = +/- .005"	ANGLES = +/- 1/2°
ALL SPECIFICATIONS SUBJECT TO CHANGE WITHOUT NOTICE.	
APPRV'D	CODE IDENT:
	19477

TITLE
TURN COUNTING DIAL

CARLSBAD CALIFORNIA

PART NO. MD30