

Customer Information Sheet

DRAWING No.: T1558-46

IF IN DOUBT - ASK

©

NOT TO SCALE

THIRD ANGLE PROJECTION

ALL DIMENSIONS IN mm

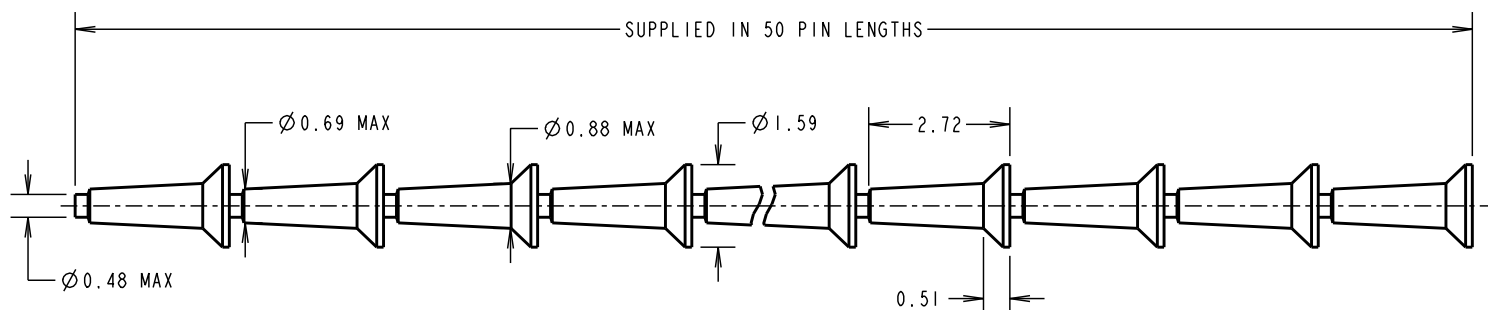

NOTES:

1. STRIPS ARE PACKED IN BOXES, 50 STRIPS PER BOX (QUANTITY 2500 PINS PER BOX).
2. USE WITH TRACK PIN INSERTION TOOL Z1002-00 AND INSTRUCTION SHEET IS-06.
3. THESE ITEMS ARE RoHS COMPLIANT.
4. RECOMMENDED MOUNTING HOLE SIZE = $\varnothing 0.83 +0.00/-0.03$ IN A 0.80mm THICK BOARD.

SM	9	22.02.11	11152
NAME	ISS.	DATE	C/NOTE
APPROVED: S. MCCULLAGH			
CHECKED: M. G. PLESTED			
DRAWN: J. PETERS			
CUSTOMER REF.:			
ASSEMBLY DRG:			

HARWIN

HARWIN USA
TEL: 603 893 5376
FAX: 603 893 5396
mis@harwin.com

HARWIN Europe (UK)
TEL: 023 9231 4545
FAX: 023 9231 4590
mis@harwin.co.uk

HARWIN Asia
TEL: +65 6 779 4909
FAX: +65 6 779 3868
mis@harwin.com.sg

THIS DRAWING AND ANY INFORMATION OR DESCRIPTIVE MATTER SET OUT HEREON ARE CONFIDENTIAL AND COPYRIGHT PROPERTY OF THE HARWIN GROUP AND MUST NOT BE DISCLOSED, LOANED, COPIED OR USED FOR MANUFACTURING, TENDERING OR FOR ANY OTHER PURPOSE WITHOUT THEIR WRITTEN PERMISSION.

TOLERANCES

X. = $\pm 1\text{mm}$
X.X = $\pm 0.25\text{mm}$
X.XX = $\pm 0.10\text{mm}$
X.XXX = $\pm 0.01\text{mm}$
ANGLES = $\pm 5^\circ$
UNLESS STATED

MATERIAL:

BRASS CW614N M (CuZn39Pb3)
TO BS EN 12164:1998

FINISH: 100% TIN OVER NICKEL

S/AREA: mm²

TITLE:

CONTINUOUS TRACK PIN

DRAWING NUMBER:

T1558-46

SHT
2 OF 2

Customer Information Sheet

DRAWING No.: T1559-46

IF IN DOUBT - ASK

©

NOT TO SCALE

THIRD ANGLE PROJECTION

ALL DIMENSIONS IN mm

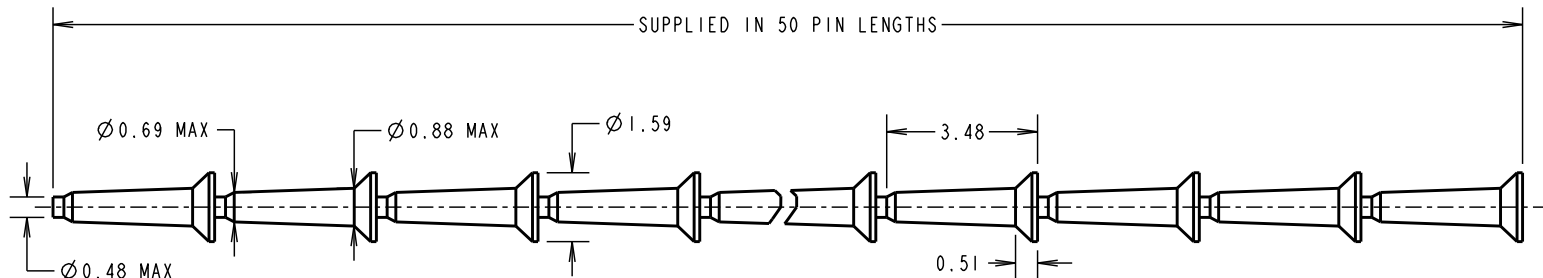

NOTES:

1. STRIPS ARE PACKED IN BOXES, 50 STRIPS PER BOX (QUANTITY 2500 PINS PER BOX).
2. USE WITH TRACK PIN INSERTION TOOL Z1002-00 AND INSTRUCTION SHEET IS-06.
3. THESE ITEMS ARE RoHS COMPLIANT.
4. RECOMMENDED MOUNTING HOLE SIZE = $\varnothing 0.83 +0.00/-0.03$ IN A 1.60mm THICK BOARD.

SM	9	22.02.11	11152
NAME	ISS.	DATE	C/NOTE
APPROVED: S. MCCULLAGH			
CHECKED: M. G. PLESTED			
DRAWN: J. PETERS			
CUSTOMER REF.:			
ASSEMBLY DRG:			

HARWIN

THIS DRAWING AND ANY INFORMATION OR DESCRIPTIVE MATTER SET OUT HEREON ARE CONFIDENTIAL AND COPYRIGHT PROPERTY OF THE HARWIN GROUP AND MUST NOT BE DISCLOSED, LOANED, COPIED OR USED FOR MANUFACTURING, TENDERING OR FOR ANY OTHER PURPOSE WITHOUT THEIR WRITTEN PERMISSION.

TOLERANCES
 X. = ± 1 mm
 X.X = ± 0.25 mm
 X.XX = ± 0.10 mm
 X.XXX = ± 0.01 mm
 ANGLES = $\pm 5^\circ$
 UNLESS STATED

MATERIAL:
 (BRASS CW614N M (CuZn39Pb3) TO BS EN 12164:1998)
FINISH: 100% TIN OVER NICKEL
S/AREA: mm²

TITLE:
 CONTINUOUS TRACK PIN
DRAWING NUMBER:
 T1559-46

SHT
 2 OF 2

HARWIN USA TEL: 603 893 5376 FAX: 603 893 5396 mis@harwin.com	HARWIN Europe (UK) TEL: 023 9231 4545 FAX: 023 9231 4590 mis@harwin.co.uk	HARWIN Asia TEL: +65 6 779 4909 FAX: +65 6 779 3868 mis@harwin.com.sg
---	---	---

Customer Information Sheet

DRAWING No.: T1560-46

IF IN DOUBT - ASK

©

NOT TO SCALE

THIRD ANGLE PROJECTION

ALL DIMENSIONS IN mm

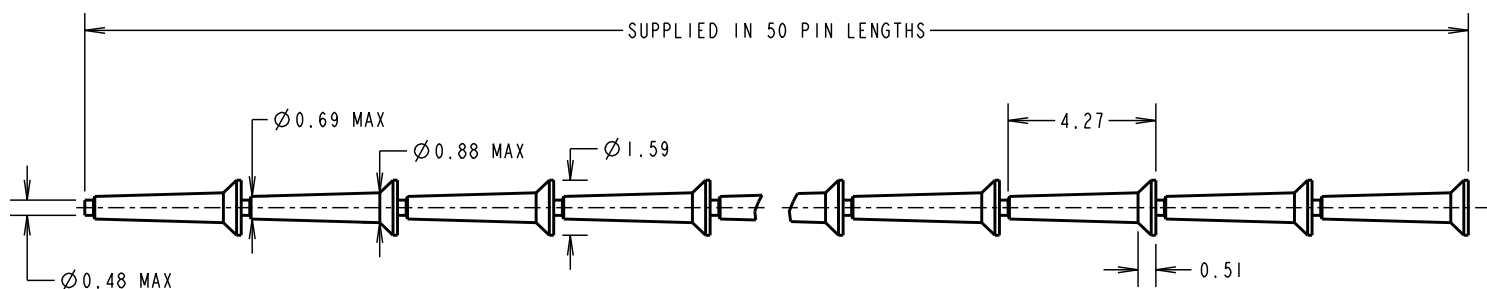

NOTES:

1. STRIPS ARE PACKED IN BOXES, 50 STRIPS PER BOX (QUANTITY 2500 PINS PER BOX).
2. USE WITH TRACK PIN INSERTION TOOL Z1002-00 AND INSTRUCTION SHEET IS-06.
3. THESE ITEMS ARE ROHS COMPLIANT.
4. RECOMMENDED MOUNTING HOLE SIZE = $\varnothing 0.83 +0.00/-0.03$ IN A 2.4mm THICK BOARD.

SM	9	23.02.11	11152
NAME	ISS.	DATE	C/NOTE
APPROVED:			
CHECKED:			
DRAWN:		J. PETERS	
CUSTOMER REF.:			
ASSEMBLY DRG:			

HARWIN

HARWIN USA TEL: 603 893 5376 FAX: 603 893 5396 mis@harwin.com	HARWIN Europe (UK) TEL: 023 9231 4545 FAX: 023 9231 4590 mis@harwin.co.uk	HARWIN Asia TEL: +65 6 779 4909 FAX: +65 6 779 3868 mis@harwin.com.sg
--	--	--

THIS DRAWING AND ANY INFORMATION OR DESCRIPTIVE MATTER SET OUT HEREON ARE CONFIDENTIAL AND COPYRIGHT PROPERTY OF THE HARWIN GROUP AND MUST NOT BE DISCLOSED, LOANED, COPIED OR USED FOR MANUFACTURING, TENDERING OR FOR ANY OTHER PURPOSE WITHOUT THEIR WRITTEN PERMISSION.

TOLERANCES
X. = ± 1 mm
X.X = ± 0.25 mm
X.XX = ± 0.10 mm
X.XXX = ± 0.01 mm
ANGLES = $\pm 5^\circ$
UNLESS STATED

MATERIAL:
(BRASS CW614N M (CuZn39Pb3) TO BS EN 12164:1998)
FINISH: 100% TIN OVER NICKEL
S/AREA: mm²

TITLE:
CONTINUOUS TRACK PIN
DRAWING NUMBER:
T1560-46

SHT
2
OF
2

Customer Information Sheet

DRAWING No.: T1561-46

IF IN DOUBT - ASK

©

NOT TO SCALE

THIRD ANGLE PROJECTION

ALL DIMENSIONS IN mm

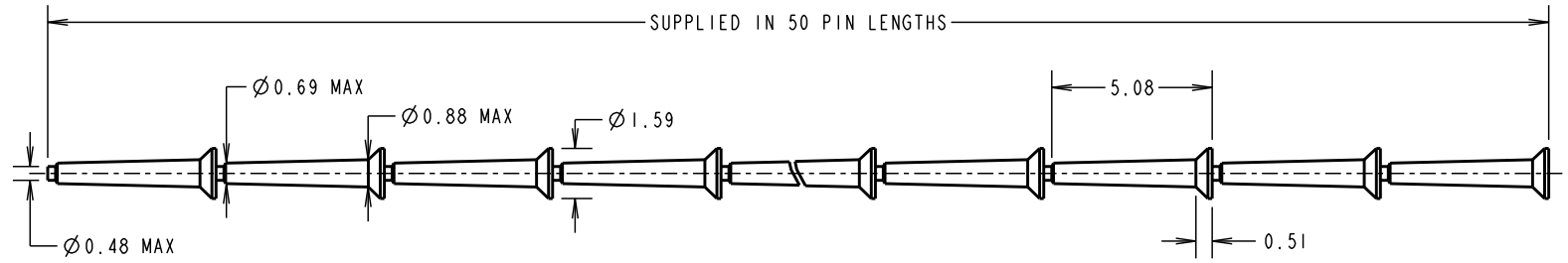

NOTES:

1. STRIPS ARE PACKED IN BOXES, 50 STRIPS PER BOX (QUANTITY 2500 PINS PER BOX).
2. USE WITH TRACK PIN INSERTION TOOL Z1002-00 AND INSTRUCTION SHEET IS-06.
3. THESE ITEMS ARE RoHS COMPLIANT.
4. RECOMMENDED MOUNTING HOLE SIZE = $\varnothing 0.83 +0.00/-0.03$ IN A 3.17mm THICK BOARD.

SM	9	23.02.11	11152
NAME	ISS.	DATE	C/NOTE
APPROVED: S. MCCULLAGH			
CHECKED: M. G. PLESTED			
DRAWN: J. PETERS			
CUSTOMER REF.:			
ASSEMBLY DRG:			

HARWIN

THIS DRAWING AND ANY INFORMATION OR DESCRIPTIVE MATTER SET OUT HEREON ARE CONFIDENTIAL AND COPYRIGHT PROPERTY OF THE HARWIN GROUP AND MUST NOT BE DISCLOSED, LOANED, COPIED OR USED FOR MANUFACTURING, TENDERING OR FOR ANY OTHER PURPOSE WITHOUT THEIR WRITTEN PERMISSION.

TOLERANCES
 X. = $\pm 1\text{mm}$
 X.X = $\pm 0.25\text{mm}$
 X.XX = $\pm 0.10\text{mm}$
 X.XXX = $\pm 0.01\text{mm}$
 ANGLES = $\pm 5^\circ$
 UNLESS STATED

MATERIAL:
 (BRASS CW614N M (CuZn39Pb3)
 TO BS EN 12164:1998)

FINISH: 100% TIN OVER NICKEL

S/AREA: mm²

TITLE:
 CONTINUOUS TRACK PIN

DRAWING NUMBER:
 T1561-46

SHT
 2
 OF
 2

HARWIN USA TEL: 603 893 5376 FAX: 603 893 5396 mis@harwin.com	HARWIN Europe (UK) TEL: 023 9231 4545 FAX: 023 9231 4590 mis@harwin.co.uk	HARWIN Asia TEL: +65 6 779 4909 FAX: +65 6 779 3868 mis@harwin.com.sg
---	---	---

Customer Information Sheet

DRAWING No.: T1562-46

IF IN DOUBT - ASK

©

NOT TO SCALE

THIRD ANGLE PROJECTION

ALL DIMENSIONS IN mm

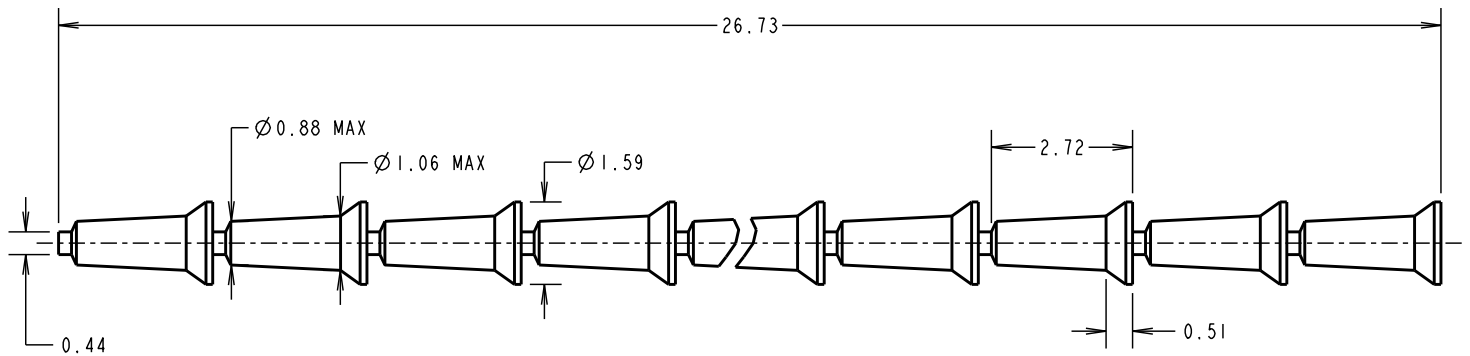

NOTES:

1. STRIPS ARE PACKED IN BOXES, 50 STRIPS PER BOX (QUANTITY 2500 PINS PER BOX).
2. USE WITH TRACK PIN INSERTION TOOL Z1002-00 AND INSTRUCTION SHEET IS-06.
3. THESE ITEMS ARE RoHS COMPLIANT.
4. RECOMMENDED MOUNTING HOLE SIZE = $\varnothing 1.00 +0.00/-0.03$ IN A 0.80mm THICK BOARD.

SM	10	23.02.11	11152
NAME	ISS.	DATE	C/NOTE
APPROVED: S. MCCULLAGH			
CHECKED: M. G. PLESTED			
DRAWN: J. PETERS			
CUSTOMER REF.:			
ASSEMBLY DRG:			

HARWIN

THIS DRAWING AND ANY INFORMATION OR DESCRIPTIVE MATTER SET OUT HEREON ARE CONFIDENTIAL AND COPYRIGHT PROPERTY OF THE HARWIN GROUP AND MUST NOT BE DISCLOSED, LOANED, COPIED OR USED FOR MANUFACTURING, TENDERING OR FOR ANY OTHER PURPOSE WITHOUT THEIR WRITTEN PERMISSION.

TOLERANCES
 X. = ± 1 mm
 X.X = ± 0.25 mm
 X.XX = ± 0.10 mm
 X.XXX = ± 0.01 mm
 ANGLES = $\pm 5^\circ$
 UNLESS STATED

MATERIAL:
 (BRASS CW614N M (CuZn39Pb3) TO BS EN 12164:1998)

FINISH: 100% TIN OVER NICKEL
S/AREA: mm²

TITLE:
 CONTINUOUS TRACK PIN

DRAWING NUMBER:
 T1562-46

SHT
 2
 OF
 2

HARWIN USA TEL: 603 893 5376 FAX: 603 893 5396 mis@harwin.com	HARWIN Europe (UK) TEL: 023 9231 4545 FAX: 023 9231 4590 mis@harwin.co.uk	HARWIN Asia TEL: +65 6 779 4909 FAX: +65 6 779 3868 mis@harwin.com.sg
---	---	---

Customer Information Sheet

DRAWING No.: T1563-46

IF IN DOUBT - ASK

©

NOT TO SCALE

THIRD ANGLE PROJECTION

ALL DIMENSIONS IN mm

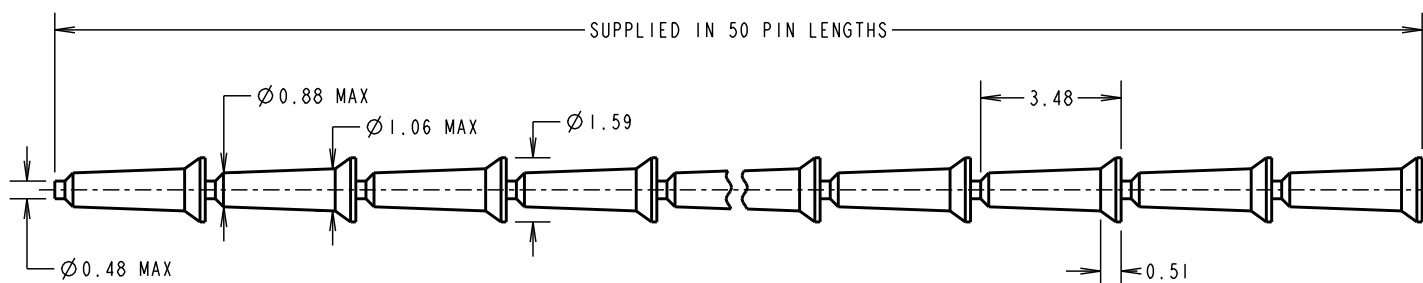

NOTES:

1. STRIPS ARE PACKED IN BOXES, 50 STRIPS PER BOX (QUANTITY 2500 PINS PER BOX).
2. USE WITH TRACK PIN INSERTION TOOL Z1002-00 AND INSTRUCTION SHEET IS-06.
3. THESE ITEMS ARE RoHS COMPLIANT.
4. RECOMMENDED MOUNTING HOLE SIZE = $\varnothing 1.00 +0.00/-0.03$ IN A 1.60mm THICK BOARD.

SM	12	23.02.11	11152
NAME	ISS.	DATE	C/NOTE
APPROVED:		S. MCCULLAGH	
CHECKED:		M. G. PLESTED	
DRAWN:		J. PETERS	
CUSTOMER REF.:			
ASSEMBLY DRG:			

HARWIN

THIS DRAWING AND ANY INFORMATION OR DESCRIPTIVE MATTER SET OUT HEREON ARE CONFIDENTIAL AND COPYRIGHT PROPERTY OF THE HARWIN GROUP AND MUST NOT BE DISCLOSED, LOANED, COPIED OR USED FOR MANUFACTURING, TENDERING OR FOR ANY OTHER PURPOSE WITHOUT THEIR WRITTEN PERMISSION.

TOLERANCES

X. = ± 1 mm
 X.X = ± 0.25 mm
 X.XX = ± 0.10 mm
 X.XXX = ± 0.01 mm

ANGLES = $\pm 5^\circ$

UNLESS STATED

MATERIAL:

(BRASS CW614N M (CuZn39Pb3) TO BS EN 12164:1998)

FINISH: 100% TIN OVER NICKEL

S/AREA:

mm²

TITLE:

CONTINUOUS TRACK PIN

DRAWING NUMBER:

T1563-46

SHT
2
OF
2

HARWIN USA TEL: 603 893 5376 FAX: 603 893 5396 mis@harwin.com	HARWIN Europe (UK) TEL: 023 9231 4545 FAX: 023 9231 4590 mis@harwin.co.uk	HARWIN Asia TEL: +65 6 779 4909 FAX: +65 6 779 3868 mis@harwin.com.sg
---	---	---

Customer Information Sheet

DRAWING No.: T1564-46

IF IN DOUBT - ASK

©

NOT TO SCALE

THIRD ANGLE PROJECTION

ALL DIMENSIONS IN mm

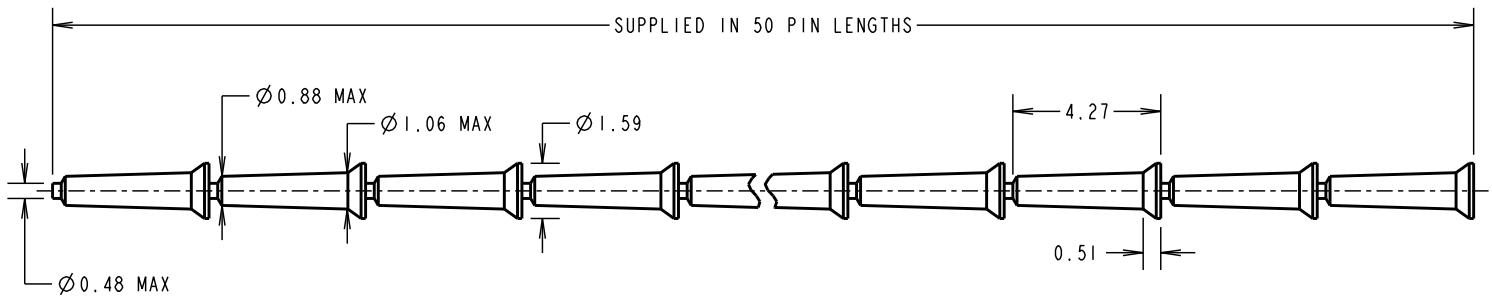

NOTES:

1. STRIPS ARE PACKED IN BOXES, 50 STRIPS PER BOX (QUANTITY 2500 PINS PER BOX).
2. USE WITH TRACK PIN INSERTION TOOL Z1002-00 AND INSTRUCTION SHEET IS-06.
3. THESE ITEMS ARE RoHS COMPLIANT.
4. RECOMMENDED MOUNTING HOLE SIZE = $\varnothing 1.00 +0.00/-0.03$ IN A 2.40mm THICK BOARD.

SM	12	23.02.11	11152
NAME	ISS.	DATE	C/NOTE
APPROVED: S. MCCULLAGH			
CHECKED: M. G. PLESTED			
DRAWN: J. PETERS			
CUSTOMER REF.:			
ASSEMBLY DRG:			

HARWIN

HARWIN USA TEL: 603 893 5376 FAX: 603 893 5396 mis@harwin.com	HARWIN Europe (UK) TEL: 023 9231 4545 FAX: 023 9231 4590 mis@harwin.co.uk	HARWIN Asia TEL: +65 6 779 4909 FAX: +65 6 779 3868 mis@harwin.com.sg
---	---	---

THIS DRAWING AND ANY INFORMATION OR DESCRIPTIVE MATTER SET OUT HEREON ARE CONFIDENTIAL AND COPYRIGHT PROPERTY OF THE HARWIN GROUP AND MUST NOT BE DISCLOSED, LOANED, COPIED OR USED FOR MANUFACTURING, TENDERING OR FOR ANY OTHER PURPOSE WITHOUT THEIR WRITTEN PERMISSION.

TOLERANCES
 X. = ±1mm
 X.X = ±0.25mm
 X.XX = ±0.10mm
 X.XXX = ±0.01mm
 ANGLES = ±5°
 UNLESS STATED

MATERIAL:
 (BRASS CW614N M (CuZn39Pb3) TO BS EN 12164:1998)
FINISH: 100% TIN OVER NICKEL
S/AREA: mm²

TITLE:
 CONTINUOUS TRACK PIN
DRAWING NUMBER:
 T1564-46

SHT
2
OF
2

Customer Information Sheet

DRAWING No.: T1565-46

IF IN DOUBT - ASK

©

NOT TO SCALE

THIRD ANGLE PROJECTION

ALL DIMENSIONS IN mm

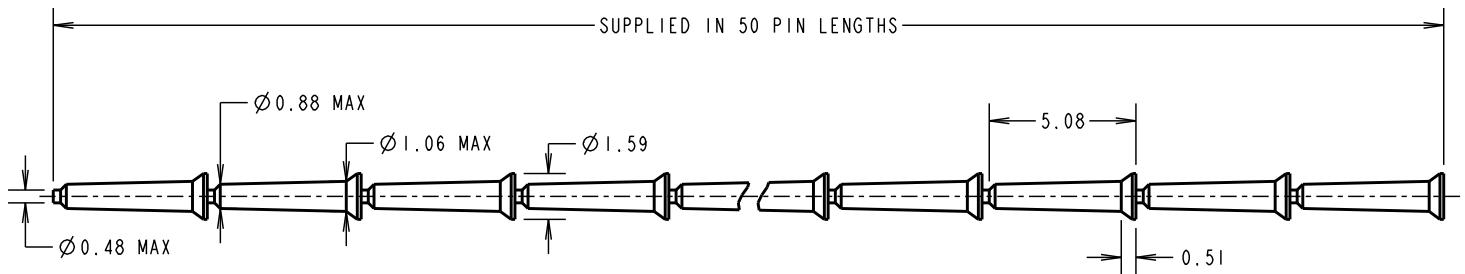

NOTES:

1. STRIPS ARE PACKED IN BOXES, 50 STRIPS PER BOX (QUANTITY 2500 PINS PER BOX).
2. USE WITH TRACK PIN INSERTION TOOL Z1002-00 AND INSTRUCTION SHEET IS-06.
3. THESE ITEMS ARE RoHS COMPLIANT.
4. RECOMMENDED MOUNTING HOLE SIZE = $\varnothing 1.00 +0.00/-0.03$ IN A 3.17mm THICK BOARD.

SM	11	23.02.11	11152
NAME	ISS.	DATE	C/NOTE
APPROVED: S. MCCULLAGH			
CHECKED: M. G. PLESTED			
DRAWN: J. PETERS			
CUSTOMER REF.:			
ASSEMBLY DRG:			

HARWIN

THIS DRAWING AND ANY INFORMATION OR DESCRIPTIVE MATTER SET OUT HEREON ARE CONFIDENTIAL AND COPYRIGHT PROPERTY OF THE HARWIN GROUP AND MUST NOT BE DISCLOSED, LOANED, COPIED OR USED FOR MANUFACTURING, TENDERING OR FOR ANY OTHER PURPOSE WITHOUT THEIR WRITTEN PERMISSION.

TOLERANCES
 X. = ± 1 mm
 X.X = ± 0.25 mm
 X.XX = ± 0.10 mm
 X.XXX = ± 0.01 mm
 ANGLES = $\pm 5^\circ$
 UNLESS STATED

MATERIAL:
 (BRASS CW614N M (CuZn39Pb3) TO BS EN 12164:1998)

FINISH: 100% TIN OVER NICKEL

S/AREA: mm²

TITLE:
 CONTINUOUS TRACK PIN

DRAWING NUMBER:
 T1565-46

SHT
 2 OF 2

HARWIN USA TEL: 603 893 5376 FAX: 603 893 5396 mis@harwin.com	HARWIN Europe (UK) TEL: 023 9231 4545 FAX: 023 9231 4590 mis@harwin.co.uk	HARWIN Asia TEL: +65 6 779 4909 FAX: +65 6 779 3868 mis@harwin.com.sg
---	---	---