

# Notice for TAIYO YUDEN products

Please read this notice before using the TAIYO YUDEN products.

## REMINDERS

- Product information in this catalog is as of October 2010. All of the contents specified herein are subject to change without notice due to technical improvements, etc. Therefore, please check for the latest information carefully before practical application or usage of the Products.

Please note that Taiyo Yuden Co., Ltd. shall not be responsible for any defects in products or equipment incorporating such products, which are caused under the conditions other than those specified in this catalog or individual specification.

- Please contact Taiyo Yuden Co., Ltd. for further details of product specifications as the individual specification is available.
- Please conduct validation and verification of products in actual condition of mounting and operating environment before commercial shipment of the equipment.
- All electronic components or functional modules listed in this catalog are developed, designed and intended for use in general electronics equipment.(for AV, office automation, household, office supply, information service, telecommunications, (such as mobile phone or PC) etc.). Before incorporating the components or devices into any equipment in the field such as transportation,( automotive control, train control, ship control), transportation signal, disaster prevention, medical, public information network (telephone exchange, base station) etc. which may have direct influence to harm or injure a human body, please contact Taiyo Yuden Co., Ltd. for more detail in advance. Do not incorporate the products into any equipment in fields such as aerospace, aviation, nuclear control, submarine system, military, etc. where higher safety and reliability are especially required.

In addition, even electronic components or functional modules that are used for the general electronic equipment, if the equipment or the electric circuit require high safety or reliability function or performances, a sufficient reliability evaluation check for safety shall be performed before commercial shipment and moreover, due consideration to install a protective circuit is strongly recommended at customer's design stage.

- The contents of this catalog are applicable to the products which are purchased from our sales offices or distributors (so called "TAIYO YUDEN' s official sales channel"). It is only applicable to the products purchased from any of TAIYO YUDEN' s official sales channel.
- Please note that Taiyo Yuden Co., Ltd. shall have no responsibility for any controversies or disputes that may occur in connection with a third party's intellectual property rights and other related rights arising from your usage of products in this catalog. Taiyo Yuden Co., Ltd. grants no license for such rights.
- Caution for export**  
Certain items in this catalog may require specific procedures for export according to "Foreign Exchange and Foreign Trade Control Law" of Japan, "U.S. Export Administration Regulations", and other applicable regulations. Should you have any question or inquiry on this matter, please contact our sales staff.

# AXIAL LEADED INDUCTORS

WAVE

## FEATURES

- Extremely reliable inductors that are ideal for automatic insertion.
- Highly efficient automated production processes can provide high quality inductors in large volumes.
- Wide selection of configurations including axial leaded, formed radial leads and bulk products to meet most manufacturing needs.

## APPLICATIONS

- Use for TVs, DVD, audio equipment, communication instrument, tuner, and general electrical instrument.

## ORDERING CODE

L A L △ 0 2 T B R 2 2 K ○ ○ ○ ○ ○

<b>1 Type</b> LA Axial leaded inductor	<b>2 Product Specification</b> L△ Standard type N△ High current type P△ Standard type (Lead diameter: 0.45φmm) △=Blank space	<b>3 Dimensions (L×D) (mm) max</b> 02 3.4×2.3 (LAL/LAP) 3.6×2.4 (LAN)	<b>4 Lead configurations</b> KR Formed lead/bulk NA Axial lead/bulk TA Axial lead (26mm lead space) /ammo pack TB Axial lead (52mm lead space) /ammo pack VD Formed lead/ammo pack	<b>5 Nominal inductance (μH)</b> example 1R5 1.5 120 12 ※R=decimal point	<b>6 Inductance tolerance (%)</b> J ±5 K ±10	<b>7 Internal code</b> △△△△△ Standard product △=Blank space
---	--	---	---	---	--	---

## EXTERNAL DIMENSIONS/STANDARD QUANTITY

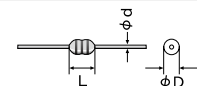

Type	Dimensions [mm] (inch)			Taped		Bulk		Standard Quantity (pcs)						
	L	φD	φd	Straight	Formed	Straight	Formed	Lead Configuration Code						
								TA	TB	VD	NA	KR		
LAL02	3.4max. (0.134max.)	2.3max. (0.091max.)	0.5±0.05 (0.018±0.002)	TB 	VD  Pitch: 5mm(0.197)	NA 	---	---	---	---	---	2,000	500	2,000
LAP02	3.4max. (0.134max.)	2.3max. (0.091max.)	0.45±0.05 (0.018±0.002)	TA 	---	---	KR  Pitch: 5mm(0.197)	2,000	---	---	---	---	---	2,000
LAN02	3.6max. (0.142max.)	2.4max. (0.094max.)		---	---	---	---	---	---	---	---	---	---	---

Unit : mm (inch)

## AVAILABLE INDUCTANCE RANGE

Range	Type	LAL/LAP02		LAN02	
		I <sub>max</sub> [A]	R <sub>dc</sub> max[Ω]	I <sub>max</sub> [A]	R <sub>dc</sub> max[Ω]
Inductance [μH]	0.1	270	0.8	500	0.32
	1	160	2.5	280	1.0
	10	44	12	120	5.6
	100	220	---	470	---
	1000	---	---	---	---

\* This catalog contains the typical specification only due to the limitation of space. When you consider the purchase of our products, please check our specification. For details of each product (characteristics graph, reliability information, precautions for use, and so on), see our Web site (<http://www.ty-top.com/>) or CD catalogs.

**PART NUMBERS**

**LAL/LAP02**

Ordering code	EHS (Environmental Hazardous Substances)	Inductance [ $\mu$ H]	Inductance Tolerance	Q (min.)	Measuring frequency [MHz]	Self-resonant frequency [MHz] (min.)	DC Resistance [ $\Omega$ ] (max.)	Rated current [mA] (max.)
LA□ 02 ○ R22K	RoHS	0.22	±10%	35	25.2	450	0.40	400
LA□ 02 ○ R27K	RoHS	0.27				410	0.43	380
LA□ 02 ○ R33K	RoHS	0.33				360	0.48	370
LA□ 02 ○ R39K	RoHS	0.39				300	0.51	350
LA□ 02 ○ R47K	RoHS	0.47				230	0.56	330
LA□ 02 ○ R56K	RoHS	0.56				210	0.61	320
LA□ 02 ○ R68K	RoHS	0.68				190	0.67	310
LA□ 02 ○ R82K	RoHS	0.82				170	0.74	290
LA□ 02 ○ 1R0K	RoHS	1.0				150	0.80	270
LA□ 02 ○ 1R2K	RoHS	1.2				110	0.9	260
LA□ 02 ○ 1R5K	RoHS	1.5				80	1.0	250
LA□ 02 ○ 1R8K	RoHS	1.8				60	1.1	240
LA□ 02 ○ 2R2K	RoHS	2.2				45	1.2	230
LA□ 02 ○ 2R7K	RoHS	2.7				40	1.3	220
LA□ 02 ○ 3R3K	RoHS	3.3				38	1.4	210
LA□ 02 ○ 3R9K	RoHS	3.9				35	1.6	200
LA□ 02 ○ 4R7K	RoHS	4.7				32	1.7	190
LA□ 02 ○ 5R6K	RoHS	5.6				30	1.9	180
LA□ 02 ○ 6R8K	RoHS	6.8		28	2.0	175		
LA□ 02 ○ 8R2K	RoHS	8.2		26	2.2	165		
LA□ 02 ○ 100K	RoHS	10		24	2.5	160		
LA□ 02 ○ 120K	RoHS	12		22	2.5	150		
LA□ 02 ○ 150K	RoHS	15		20	2.8	145		
LA□ 02 ○ 180K	RoHS	18		18	3.1	140		
LA□ 02 ○ 220K	RoHS	22		17	3.4	130		
LA□ 02 ○ 270K	RoHS	27		16	4.3	80		
LA□ 02 ○ 330K	RoHS	33		14	4.7	76		
LA□ 02 ○ 390K	RoHS	39		13	5.2	74		
LA□ 02 ○ 470K	RoHS	47		12	5.8	70		
LA□ 02 ○ 560K	RoHS	56		11	6.4	68		
LA□ 02 ○ 680K	RoHS	68		10	7.2	64		
LA□ 02 ○ 820K	RoHS	82		9.5	11	46		
LA□ 02 ○ 101K	RoHS	100		9.0	12	44		
LA□ 02 ○ 121K	RoHS	120		8.0	13	42		
LA□ 02 ○ 151K	RoHS	150		6.0	16	39		
LA□ 02 ○ 181K	RoHS	180		5.5	18	37		
LA□ 02 ○ 221K	RoHS	220		5.0	20	35		

□ Please specify the Product Specification (Lead) code. (L: standard 0.5mm or P: 0.45mm)  
 ○ Please specify the Lead configuration code.

**FERRITE PRODUCTS**

\* This catalog contains the typical specification only due to the limitation of space. When you consider the purchase of our products, please check our specification. For details of each product (characteristics graph, reliability information, precautions for use, and so on), see our Web site (<http://www.ty-top.com/>) or CD catalogs.

**PART NUMBERS**

**FAN02**

Ordering code	EHS (Environmental Hazardous Substances)	Inductance [ $\mu$ H]	Inductance Tolerance	Q (min.)	Measuring frequency [MHz]	Self-resonant frequency [MHz] (min.)	DC Resistance [ $\Omega$ ] (max.)	Rated current [mA] (max.)
LAN02 ○ R12K	RoHS	0.12	±10%	50	25.2	500	0.12	850
LAN02 ○ R15K	RoHS	0.15				500	0.14	800
LAN02 ○ R18K	RoHS	0.18				500	0.15	760
LAN02 ○ R22K	RoHS	0.22				500	0.16	730
LAN02 ○ R27K	RoHS	0.27				500	0.18	690
LAN02 ○ R33K	RoHS	0.33				480	0.19	660
LAN02 ○ R39K	RoHS	0.39				430	0.21	640
LAN02 ○ R47K	RoHS	0.47				380	0.23	610
LAN02 ○ R56K	RoHS	0.56				350	0.25	580
LAN02 ○ R68K	RoHS	0.68				310	0.27	550
LAN02 ○ R82K	RoHS	0.82	270	0.29	520			
LAN02 ○ 1R0J	RoHS	1.0	240	0.32	500			
LAN02 ○ 1R2J	RoHS	1.2	±5%	40	7.96	210	0.35	480
LAN02 ○ 1R5J	RoHS	1.5				190	0.38	450
LAN02 ○ 1R8J	RoHS	1.8				140	0.42	430
LAN02 ○ 2R2J	RoHS	2.2				90	0.47	410
LAN02 ○ 2R7J	RoHS	2.7				70	0.52	390
LAN02 ○ 3R3J	RoHS	3.3				50	0.57	370
LAN02 ○ 3R9J	RoHS	3.9				35	0.63	360
LAN02 ○ 4R7J	RoHS	4.7				32	0.69	340
LAN02 ○ 5R6J	RoHS	5.6				30	0.75	320
LAN02 ○ 6R8J	RoHS	6.8				28	0.84	310
LAN02 ○ 8R2J	RoHS	8.2	26	0.92	290			
LAN02 ○ 100J	RoHS	10	24	1.0	280			
LAN02 ○ 120J	RoHS	12	50	2.52	22	1.0	280	
LAN02 ○ 150J	RoHS	15			20	1.2	265	
LAN02 ○ 180J	RoHS	18			18	1.3	250	
LAN02 ○ 220J	RoHS	22			17	1.5	235	
LAN02 ○ 270J	RoHS	27			15	1.7	220	
LAN02 ○ 330J	RoHS	33			14	2.2	180	
LAN02 ○ 390J	RoHS	39			13	2.4	170	
LAN02 ○ 470J	RoHS	47			12	2.8	160	
LAN02 ○ 560J	RoHS	56			10	4.1	140	
LAN02 ○ 680J	RoHS	68			9.2	4.5	130	
LAN02 ○ 820J	RoHS	82	8.8	5.0	125			
LAN02 ○ 101J	RoHS	100	8.0	5.6	120			
LAN02 ○ 121J	RoHS	120	0.796	50	6.6	9.2	90	
LAN02 ○ 151J	RoHS	150			5.8	10.5	85	
LAN02 ○ 181J	RoHS	180			5.4	11.5	80	
LAN02 ○ 221J	RoHS	220			4.8	13	75	
LAN02 ○ 271J	RoHS	270			3.6	16	70	
LAN02 ○ 331J	RoHS	330			3.4	18	66	
LAN02 ○ 391J	RoHS	390			3.2	20	63	
LAN02 ○ 471J	RoHS	470	3.0	22	60			

○ Please specify the Lead configuration code.

\* This catalog contains the typical specification only due to the limitation of space. When you consider the purchase of our products, please check our specification. For details of each product (characteristics graph, reliability information, precautions for use, and so on), see our Web site (<http://www.ty-top.com/>) or CD catalogs.

DC Bias characteristics (Measured by HP4285A)

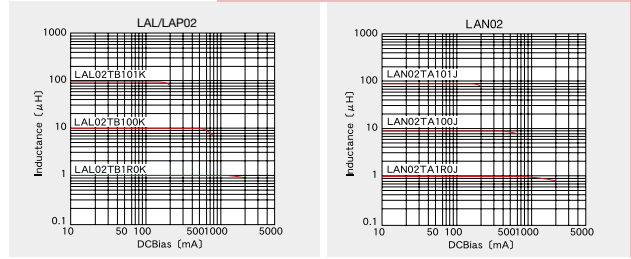

Temperature characteristics (Measured by HP4285A)

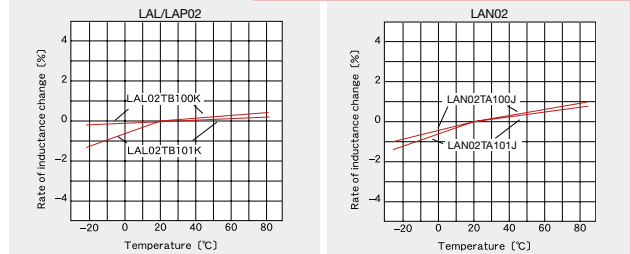

Q-Characteristics (Measured by HP4285A+HP42851A)

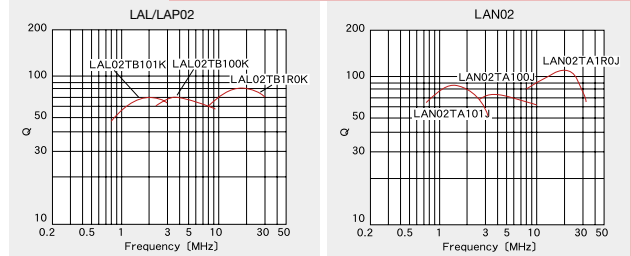

FERRITE PRODUCTS

\* This catalog contains the typical specification only due to the limitation of space. When you consider the purchase of our products, please check our specification. For details of each product (characteristics graph, reliability information, precautions for use, and so on), see our Web site (<http://www.ty-top.com/>) or CD catalogs.

# PACKAGING

## ① Minimum Quantity

### ● Taping for Straight Leads

Type	Lead Configuration code	Standard quantity (pcs.)
LAL02	TB	2,000
LAP02	TA	2,000
LAN02	TA	2,000

### ● Taping for Formed Leads

Type	Lead Configuration code	Standard quantity (pcs.)
LAL02	VD	2,000

### ● Bulk

Type	Lead Configuration code	Standard quantity (pcs.)
LAL02	NA	500
LAP02	KR	2,000
LAN02	KR	2,000

## ② Dimension

### ● NA

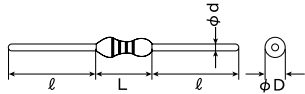

Type	Dimensions				Minimum insertion pitch
	φD	L	φd	ℓ	
LAL02	2.3max (0.091max)	3.4max (0.134max)	0.50±0.05 (0.020±0.002)	24±2.0 (0.945±0.079)	5.0 (0.197)

Unit : mm (inch)

### ● KR

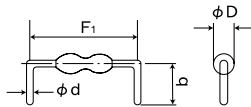

Type	Lead configuration code	Dimensions			
		φD	F <sub>1</sub>	φd	b
LAP02	KR	2.3max (0.091max)	5.0±0.5 (0.197±0.020)	0.45±0.05 (0.018±0.002)	7.0±1.0 (0.276±0.039)
LAN02	KR	2.4max (0.094max)	5.0±0.5 (0.197±0.020)	0.45±0.05 (0.018±0.002)	7.0±1.0 (0.276±0.039)

Unit : mm (inch)

### ● TA (a : 26mm lead space) (1.02 inch)

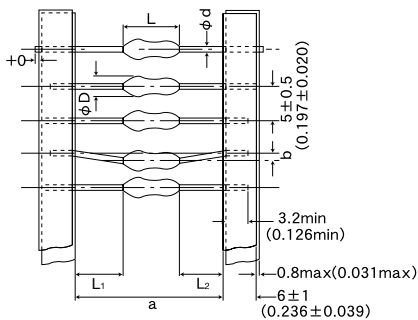

Type	Dimensions						Minimum insertion pitch
	φD	L	a	b	L <sub>1</sub> -L <sub>2</sub>	φd	
LAP02	2.3max (0.091max)	3.4max (0.134max)	26 <sup>+0.5</sup> <sub>-0</sub> (1.02 <sup>+0.020</sup> )	0.8max (0.031max)	0.5max (0.020max)	0.45±0.05 (0.018±0.002)	5.0 (0.197)
LAN02	2.4max (0.094max)	3.6max (0.142max)	26 <sup>+0.5</sup> <sub>-0</sub> (1.02 <sup>+0.020</sup> )	0.8max (0.031max)	0.5max (0.020max)	0.45±0.05 (0.018±0.002)	5.0 (0.197)

Unit : mm (inch)

### ● TB (a : 52mm lead space) (2.05 inches)

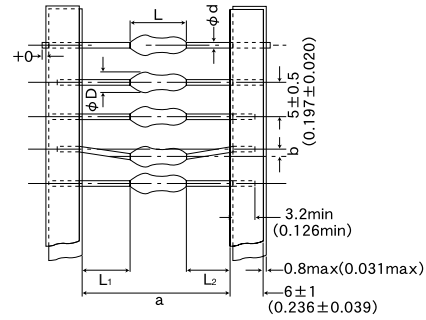

Type	Dimensions						Minimum insertion pitch
	φD	L	a	b	L <sub>1</sub> -L <sub>2</sub>	φd	
LAL02	2.3max (0.091max)	3.4max (0.134max)	52 <sup>+2</sup> <sub>-1</sub> (2.05 <sup>+0.078</sup> <sub>-0.039</sub> )	1.2max (0.047max)	1.0max (0.039max)	0.5±0.05 (0.020±0.002)	5.0 (0.197)

Unit : mm (inch)

### ● VD

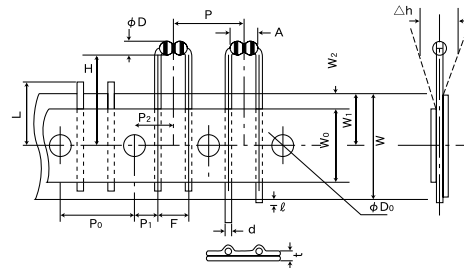

Type	Symbol	Dimensions	Symbol	Dimensions
LAL02	A	3.9max (0.154max)	W	18.0 <sup>+1.0</sup> <sub>-0.5</sub> (0.709 <sup>+0.039</sup> <sub>-0.020</sub> )
	φD	2.3max (0.091max)	W <sub>0</sub>	12.5 min. (0.492 min.)
	H	19.5±0.5 (0.768±0.020)	W <sub>1</sub>	9.0 <sup>+0.75</sup> <sub>-0.5</sub> (0.354 <sup>+0.030</sup> <sub>-0.020</sub> )
	P	12.7±1.0 (0.500±0.039)	W <sub>2</sub>	3.0 max. (0.118 max.)
	P <sub>0</sub>	12.7±0.3 (0.500±0.012)	ℓ	2.0 max. (0.079 max.)
	P <sub>1</sub>	3.85±0.7 (0.152±0.028)	φD <sub>0</sub>	4.0±0.3 (0.157±0.012)
	P <sub>2</sub>	6.35±0.5 (0.250±0.020)		
	F	5.08±0.5 (0.200±0.020)	φd	0.50±0.05 (0.020±0.002)
	△h	0±1.0 (0±0.039)	L	11.0 max. (0.433 max.)
	-	-	t	0.5±0.2 (0.020±0.008)

Unit : mm (inch)

\* This catalog contains the typical specification only due to the limitation of space. When you consider the purchase of our products, please check our specification. For details of each product (characteristics graph, reliability information, precautions for use, and so on), see our Web site (<http://www.ty-top.com/>) or CD catalogs.

# RADIAL LEADED INDUCTORS



WAVE

## FEATURES

- The LHL08~LHL16 series radial inductors are encapsulated in a resin housing which adds to the stability of the mounted part on a printed circuit board.
- The LHL08/LHL10/LHL13/LHL16 series are for high current applications.
- The LHLP10/LHLP12/LHLP16 series are shielded type for high current applications.
- LHLP10 series is also available in packaging.

## APPLICATIONS

- Ideal for use as a power choke coil in general household appliances (TVS, PDPTV, LCDTV, DVD, etc) and industrial equipment.
- Can also be used as a peaking coil in filtering applications.

## OPERATING TEMP.

- -25°C~105°C (Including self-generated heat)

## ORDERING CODE

L H △ L △ 0 8 T B 1 0 1 K ○ ○ ○

**1 Type**

LH	Radial leaded inductor
----	------------------------

**2 Configuration**

L△	Standard type Taping available
LP	Shielded type Bulk

△=Blank space

**3 External dimensions (mm max)**

08	9.0
10	11.0
12	13.0
13	14.0
16	17.0

**4 Packaging Code**

NB	Bulk (LHL)
TB	Ammo packaging (LHL)

**5 Nominal Inductance (μH)**

example	
1R0	1.0
150	15
102	1000

※R=Decimal point

**6 Inductance Tolerances (%)**

J	±5
K	±10
M	±20
N	±30

**7 Internal code**

△△△	Standard product
-----	------------------

△=Blank space

## EXTERNAL DIMENSIONS/STANDARD QUANTITY

Type	Fig.	D	H <sub>2</sub>	ℓ	F	φd	Standard Quantity (pcs)		
							Box	Bulk	Taped
LHL08		9.0 max. (0.354 max.)	9.5 max. (0.374 max.)	5.0±1.0 (0.197±0.039)	5.0±1.0 (0.197±0.039)	0.6±0.05 (0.024±0.002)	—	100	1000
LHL10		11.0 max. (0.433 max.)	14.0 max. (0.551 max.)	5.0±1.0 (0.197±0.039)	5.0±1.0 (0.197±0.039)	0.6±0.05 (0.024±0.002)	—	50	500
LHL13		14.0 max. (0.551 max.)	17.0 max. (0.669 max.)	5.0±1.0 (0.197±0.039)	7.5±1.0 (0.295±0.039)	0.8±0.05 (0.031±0.002)	—	25	500
LHL16		17.0 max. (0.669 max.)	21.0 max. (0.827 max.)	5.0±1.0 (0.197±0.039)	7.5±1.0 (0.295±0.039)	0.8±0.05 (0.031±0.002)	500	—	250
LHLP10		11.0 max. (0.433 max.)	11.0 max. (0.433 max.)	5.0±1.0 (0.197±0.039)	5.0±1.0 (0.197±0.039)	0.6±0.05 (0.024±0.004)	500	—	200
LHLP12		13.0 max. (0.512 max.)	16.0 max. (0.624 max.)	5.0±1.0 (0.197±0.039)	5.0±1.0 (0.197±0.039)	0.6±0.05 (0.024±0.004)	300	—	—
LHLP16		17.0 max. (0.669 max.)	19.0 max. (0.741 max.)	5.0±1.0 (0.197±0.039)	7.5±1.0 (0.295±0.039)	0.8±0.05 (0.031±0.004)	200	—	—

Unit : mm (inch)

## AVAILABLE INDUCTANCE RANGE

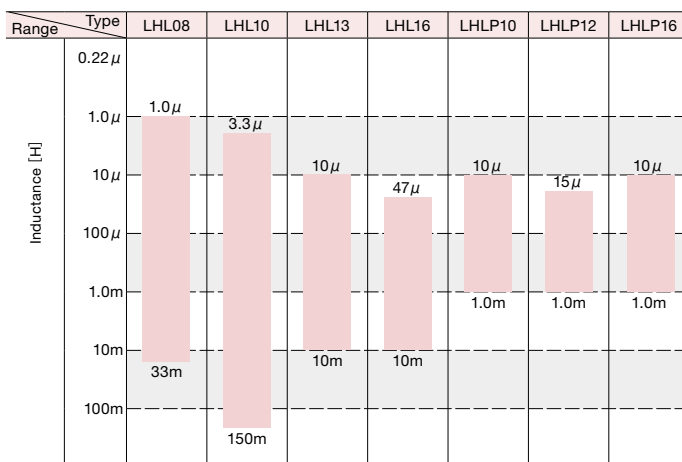

\* This catalog contains the typical specification only due to the limitation of space. When you consider the purchase of our products, please check our specification. For details of each product (characteristics graph, reliability information, precautions for use, and so on), see our Web site (<http://www.ty-top.com/>) or CD catalogs.

**PART NUMBERS**

**LHL08**

Ordering code	EHS (Environmental Hazardous Substances)	Inductance [ $\mu$ H]	Inductance Tolerance	Q (min.)	Self-resonant frequency [MHz] (min.)	DC Resistance [ $\Omega$ ] (max.)	Rated current [A] (max.)	Measuring frequency [MHz]	
LHL08□1R0N	RoHS	1.0	±30%	40	76	0.013	4.7	7.96	
LHL08□1R5M	RoHS	1.5	±20%		65	0.014	4.4		
LHL08□2R2M	RoHS	2.2			56	0.017	4.1		
LHL08□2R7M	RoHS	2.7			48	0.019	3.5		
LHL08□3R3M	RoHS	3.3			41	0.021	3.2		
LHL08□3R9M	RoHS	3.9			33	0.024	3.1		
LHL08□4R7M	RoHS	4.7			30	0.025	3.0		
LHL08□5R6M	RoHS	5.6			23	0.028	2.9		
LHL08□6R8M	RoHS	6.8			21	0.030	2.8		
LHL08□8R2M	RoHS	8.2			19	0.034	2.5		
LHL08□100K	RoHS	10		±10%	65	17	0.041	2.4	2.52
LHL08□120K	RoHS	12	50		16	0.044	2.3		
LHL08□150K	RoHS	15			13	0.053	2.0		
LHL08□180K	RoHS	18			12	0.060	1.9		
LHL08□220K	RoHS	22			11	0.068	1.8		
LHL08□270K	RoHS	27	40		10	0.091	1.5		
LHL08□330K	RoHS	33			8.8	0.10	1.4		
LHL08□390K	RoHS	39			8.4	0.12	1.3		
LHL08□470K	RoHS	47			8.2	0.15	1.2		
LHL08□560K	RoHS	56	35		7.9	0.17	1.1		
LHL08□680K	RoHS	68			7.0	0.20	1.0		
LHL08□820K	RoHS	82			6.5	0.22	0.90		
LHL08□101K	RoHS	100			25	5.7	0.32	0.79	
LHL08□121K	RoHS	120	5.2			0.36	0.70		
LHL08□151K	RoHS	150	20			4.7	0.41	0.64	
LHL08□181K	RoHS	180				35	4.2	0.66	
LHL08□221K	RoHS	220	3.7		0.73		0.53		
LHL08□271K	RoHS	270	25		3.5	0.85	0.51		
LHL08□331K	RoHS	330			3.2	0.97	0.44		
LHL08□391K	RoHS	390	20		2.9	1.1	0.41		
LHL08□471K	RoHS	470		25	2.4	1.3	0.38		
LHL08□561K	RoHS	560	2.2		1.5	0.35			
LHL08□681K	RoHS	680	30	2.0	1.8	0.32			
LHL08□821K	RoHS	820		1.6	2.3	0.30			
LHL08□102J	RoHS	1000	±5%	55	1.5	2.7	0.25	0.252	
LHL08□122J	RoHS	1200		45	1.4	3.2	0.22		
LHL08□152J	RoHS	1500			55	1.3	4.1		0.20
LHL08□182J	RoHS	1800				1.2	4.8		0.19
LHL08□222J	RoHS	2200				1.1	5.6		0.16
LHL08□272J	RoHS	2700				1.0	7.5		0.15
LHL08□332J	RoHS	3300				0.85	8.5		0.14
LHL08□392J	RoHS	3900		0.78		9.7	0.11		
LHL08□472J	RoHS	4700		65	0.68	14	0.10		
LHL08□562J	RoHS	5600			0.62	16	0.093		
LHL08□682J	RoHS	6800			0.61	18	0.092		
LHL08□822J	RoHS	8200			0.60	20	0.084		
LHL08□103J	RoHS	10000		60	0.48	32	0.070		
LHL08□123J	RoHS	12000			0.44	36	0.064		
LHL08□153J	RoHS	15000			0.35	62	0.051		
LHL08□183J	RoHS	18000			0.30	72	0.048		
LHL08□223J	RoHS	22000			0.28	82	0.044		
LHL08□273J	RoHS	27000			0.25	90	0.042		
LHL08□333J	RoHS	33000			0.23	100	0.040		

□ Please specify the packaging code. (TB: Taping, NB: Bulk)

**LHL10**

Ordering code	EHS (Environmental Hazardous Substances)	Inductance [ $\mu$ H]	Inductance Tolerance	Q (min.)	Self-resonant frequency [MHz] (min.)	DC Resistance [ $\Omega$ ] (max.)	Rated current [A] (max.)	Measuring frequency [MHz]
LHL10□3R3M	RoHS	3.3	±20%	50	46	0.019	4.2	7.96
LHL10□3R9M	RoHS	3.9			40	0.022	4.1	
LHL10□4R7M	RoHS	4.7			38	0.024	4.0	
LHL10□5R6M	RoHS	5.6			34	0.025	3.8	
LHL10□6R8M	RoHS	6.8			30	0.028	3.4	
LHL10□8R2M	RoHS	8.2			24	0.031	3.3	
LHL10□100K	RoHS	10	±10%	90	19	0.034	3.2	2.52
LHL10□120K	RoHS	12			16	0.038	2.8	
LHL10□150K	RoHS	15			12	0.042	2.6	
LHL10□180K	RoHS	18			9.2	0.046	2.4	
LHL10□220K	RoHS	22		60	8.6	0.061	2.1	
LHL10□270K	RoHS	27			7.1	0.069	2.0	
LHL10□330K	RoHS	33			6.8	0.078	1.9	
LHL10□390K	RoHS	39			6.7	0.085	1.8	
LHL10□470K	RoHS	47		50	6.2	0.093	1.7	
LHL10□560K	RoHS	56			5.2	0.10	1.6	

To next page

\* This catalog contains the typical specification only due to the limitation of space. When you consider the purchase of our products, please check our specification. For details of each product (characteristics graph, reliability information, precautions for use, and so on), see our Web site (<http://www.ty-top.com/>) or CD catalogs.



**PART NUMBERS**

Ordering code	EHS (Environmental Hazardous Substances)	Inductance [ $\mu$ H]	Inductance Tolerance	Q (min.)	Self-resonant frequency [MHz] (min.)	DC Resistance [ $\Omega$ ] (max.)	Rated current [A] (max.)	Measuring frequency [MHz]	
LHL10□680K	RoHS	68	±10%	40	4.9	0.12	1.5	2.52	
LHL10□820K	RoHS	82			4.7	0.13	1.4		
LHL10□101K	RoHS	100			3.8	0.18	1.2		
LHL10□121K	RoHS	120			3.2	0.25	1.0		
LHL10□151K	RoHS	150			2.9	0.29	0.95		
LHL10□181K	RoHS	180			2.6	0.40	0.80		
LHL10□221K	RoHS	220		2.3	0.44	0.75	0.796		
LHL10□271K	RoHS	270		2.1	0.50	0.70			
LHL10□331K	RoHS	330		2.0	0.56	0.68			
LHL10□391K	RoHS	390		1.8	0.62	0.63			
LHL10□471K	RoHS	470		1.7	0.84	0.57			
LHL10□561K	RoHS	560		1.5	0.93	0.52			
LHL10□681K	RoHS	680		1.4	1.0	0.48			
LHL10□821K	RoHS	820		1.3	1.4	0.42	0.252		
LHL10□102J	RoHS	1000		±5%	50	1.2		1.8	0.41
LHL10□122J	RoHS	1200				0.87		2.3	0.33
LHL10□152J	RoHS	1500				0.83		2.7	0.30
LHL10□182J	RoHS	1800				0.75		3.0	0.29
LHL10□222J	RoHS	2200	0.70			3.9		0.25	
LHL10□272J	RoHS	2700	0.67			4.3		0.24	
LHL10□332J	RoHS	3300	0.56		5.8	0.21			
LHL10□392J	RoHS	3900	0.54		6.4	0.20			
LHL10□472J	RoHS	4700	0.49		7.1	0.19			
LHL10□562J	RoHS	5600	0.41		9.0	0.17			
LHL10□682J	RoHS	6800	0.38		10	0.16			
LHL10□822J	RoHS	8200	0.36		12	0.15			
LHL10□103J	RoHS	10000	60		0.29	19		0.12	
LHL10□123J	RoHS	12000			0.27	21		0.11	
LHL10□153J	RoHS	15000			0.24	34		0.090	
LHL10□183J	RoHS	18000			0.21	38		0.081	
LHL10□223J	RoHS	22000			0.20	43		0.075	
LHL10□273J	RoHS	27000			0.15	67	0.060		
LHL10□333J	RoHS	33000	40	0.14	76	0.056			
LHL10□393J	RoHS	39000		0.13	84	0.053			
LHL10□473J	RoHS	47000		0.12	96	0.050			
LHL10□563J	RoHS	56000	30	0.10	170	0.036			
LHL10□683J	RoHS	68000		0.095	200	0.035			
LHL10□823J	RoHS	82000		0.088	210	0.033			
LHL10□104J	RoHS	100000		0.085	240	0.031			
LHL10□124J	RoHS	120000		0.070	260	0.030			
LHL10□154J	RoHS	150000		0.069	300	0.028			

□ Please specify the packaging code. (TB: Taping, NB: Bulk)

**LHL13**

Ordering code	EHS (Environmental Hazardous Substances)	Inductance [ $\mu$ H]	Inductance Tolerance	Q (min.)	Self-resonant frequency [MHz] (min.)	DC Resistance [ $\Omega$ ] (max.)	Rated current [A] (max.)	Measuring frequency [MHz]
LHL13□100K	RoHS	10	±10%	140	19	0.023	4.5	2.52
LHL13□150K	RoHS	15			12	0.028	4.0	
LHL13□220K	RoHS	22			7.6	0.035	3.4	
LHL13□330K	RoHS	33		6.9	0.043	3.2		
LHL13□470K	RoHS	47		5.6	0.052	2.8		
LHL13□680K	RoHS	68		4.4	0.070	2.4		
LHL13□101K	RoHS	100		50	3.3	0.12	2.0	0.796
LHL13□151K	RoHS	150			2.6	0.19	1.5	
LHL13□221K	RoHS	220			2.2	0.23	1.3	
LHL13□331K	RoHS	330		30	1.8	0.35	1.1	
LHL13□471K	RoHS	470			1.5	0.43	0.90	
LHL13□681K	RoHS	680			1.2	0.61	0.80	
LHL13□102J	RoHS	1000	±5%	40	1.0	1.2	0.60	0.252
LHL13□152J	RoHS	1500			0.83	1.8	0.45	
LHL13□222J	RoHS	2200			0.70	2.2	0.40	
LHL13□332J	RoHS	3300		0.60	3.4	0.33		
LHL13□472J	RoHS	4700		0.43	4.7	0.28		
LHL13□682J	RoHS	6800		30	0.38	5.6	0.25	
LHL13□103J	RoHS	10000	70	0.30	10	0.19	L:1kHz Q:0.0796MHz	

□ Please specify the packaging code. (TB: Taping, NB: Bulk)

\* This catalog contains the typical specification only due to the limitation of space. When you consider the purchase of our products, please check our specification. For details of each product (characteristics graph, reliability information, precautions for use, and so on), see our Web site (<http://www.ty-top.com/>) or CD catalogs.

**PART NUMBERS**

**LHL16**

Ordering code	EHS (Environmental Hazardous Substances)	Inductance [ $\mu$ H]	Inductance Tolerance	Q (min.)	Self-resonant frequency [MHz] (min.)	DC Resistance [ $\Omega$ ] (max.)	Rated current [A] (max.)	Measuring frequency [MHz]	
LHL16□470K	RoHS	47	±10%	70	4.5	0.046	3.7	2.52	
LHL16□680K	RoHS	68			3.9	0.054	3.3		
LHL16□101K	RoHS	100			2.7	0.077	2.9		
LHL16□151K	RoHS	150		60	2.3	0.11	2.4	0.796	
LHL16□221K	RoHS	220			1.9	0.15	2.0		
LHL16□331K	RoHS	330			40	1.6	0.21		1.5
LHL16□471K	RoHS	470				1.4	0.28		1.3
LHL16□681K	RoHS	680		±5%	20	1.2	0.35		1.1
LHL16□102J	RoHS	1000				0.84	0.74		0.86
LHL16□152J	RoHS	1500				0.69	0.93		0.75
LHL16□222J	RoHS	2200	0.56			1.4	0.60		
LHL16□332J	RoHS	3300	0.49			2.2	0.50		
LHL16□472J	RoHS	4700	0.41			2.6	0.40		
LHL16□682J	RoHS	6800	0.35		3.9	0.33			
LHL16□103J	RoHS	10000	70		0.26	7.3	0.25	L:1KHz Q:0.0796MHz	

□ Please specify the packaging code. (TB: Taping, NB: Bulk)

**LHLP10**

Ordering code	EHS (Environmental Hazardous Substances)	Nominal Inductance [ $\mu$ H]	L Measuring frequency	Inductance Tolerance	DC Resistance [ $\Omega$ ] (max.)	Rated current [A] (max.)
LHLP10□100M	RoHS	10	2.52	±20%	0.038	2.5
LHLP10□150M	RoHS	15			0.049	2.2
LHLP10□220M	RoHS	22			0.075	1.9
LHLP10□330M	RoHS	33			0.094	1.7
LHLP10□470M	RoHS	47			0.15	1.3
LHLP10□680M	RoHS	68			0.23	1.0
LHLP10□101K	RoHS	100	0.796	±10%	0.30	0.90
LHLP10□151K	RoHS	150			0.47	0.78
LHLP10□221K	RoHS	220			0.70	0.63
LHLP10□331K	RoHS	330			0.88	0.58
LHLP10□471K	RoHS	470			1.3	0.46
LHLP10□681K	RoHS	680			1.9	0.38
LHLP10□102K	RoHS	1000	0.252		3.2	0.30

□ Please specify the packaging code. (TB: Taping, NB: Bulk)

**LHLP12NB**

Ordering code	EHS (Environmental Hazardous Substances)	Nominal Inductance [ $\mu$ H]	L Measuring frequency	Inductance Tolerance	DC Resistance [ $\Omega$ ] (max.)	Rated current [A] (max.)
LHLP12NB150M	RoHS	15	2.52	±20%	0.035	3.3
LHLP12NB220M	RoHS	22			0.050	2.7
LHLP12NB330M	RoHS	33			0.070	2.4
LHLP12NB470M	RoHS	47			0.081	2.1
LHLP12NB680M	RoHS	68			0.12	1.7
LHLP12NB101K	RoHS	100			0.796	±10%
LHLP12NB151K	RoHS	150	0.24	1.3		
LHLP12NB221K	RoHS	220	0.38	0.95		
LHLP12NB331K	RoHS	330	0.46	0.89		
LHLP12NB471K	RoHS	470	0.69	0.74		
LHLP12NB681K	RoHS	680	1.1	0.58		
LHLP12NB102K	RoHS	1000	0.252		1.8	0.46

**LHLP16NB**

Ordering code	EHS (Environmental Hazardous Substances)	Nominal Inductance [ $\mu$ H]	L Measuring frequency	Inductance Tolerance	DC Resistance [ $\Omega$ ] (max.)	Rated current [A] (max.)
LHLP16NB100M	RoHS	10	1kHz	±20%	0.019	5.2
LHLP16NB150M	RoHS	15			0.025	5.1
LHLP16NB220M	RoHS	22			0.027	4.6
LHLP16NB330M	RoHS	33			0.035	4.0
LHLP16NB470K	RoHS	47			0.045	3.4
LHLP16NB680K	RoHS	68			0.062	3.1
LHLP16NB101K	RoHS	100		±10%	0.091	2.3
LHLP16NB151K	RoHS	150			0.14	1.9
LHLP16NB221K	RoHS	220			0.20	1.5
LHLP16NB331K	RoHS	330			0.31	1.3
LHLP16NB471K	RoHS	470			0.47	1.0
LHLP16NB681K	RoHS	680			0.58	0.98
LHLP16NB102K	RoHS	1000			0.94	0.74

\* This catalog contains the typical specification only due to the limitation of space. When you consider the purchase of our products, please check our specification. For details of each product (characteristics graph, reliability information, precautions for use, and so on), see our Web site (<http://www.ty-top.com/>) or CD catalogs.

DC Bias characteristics

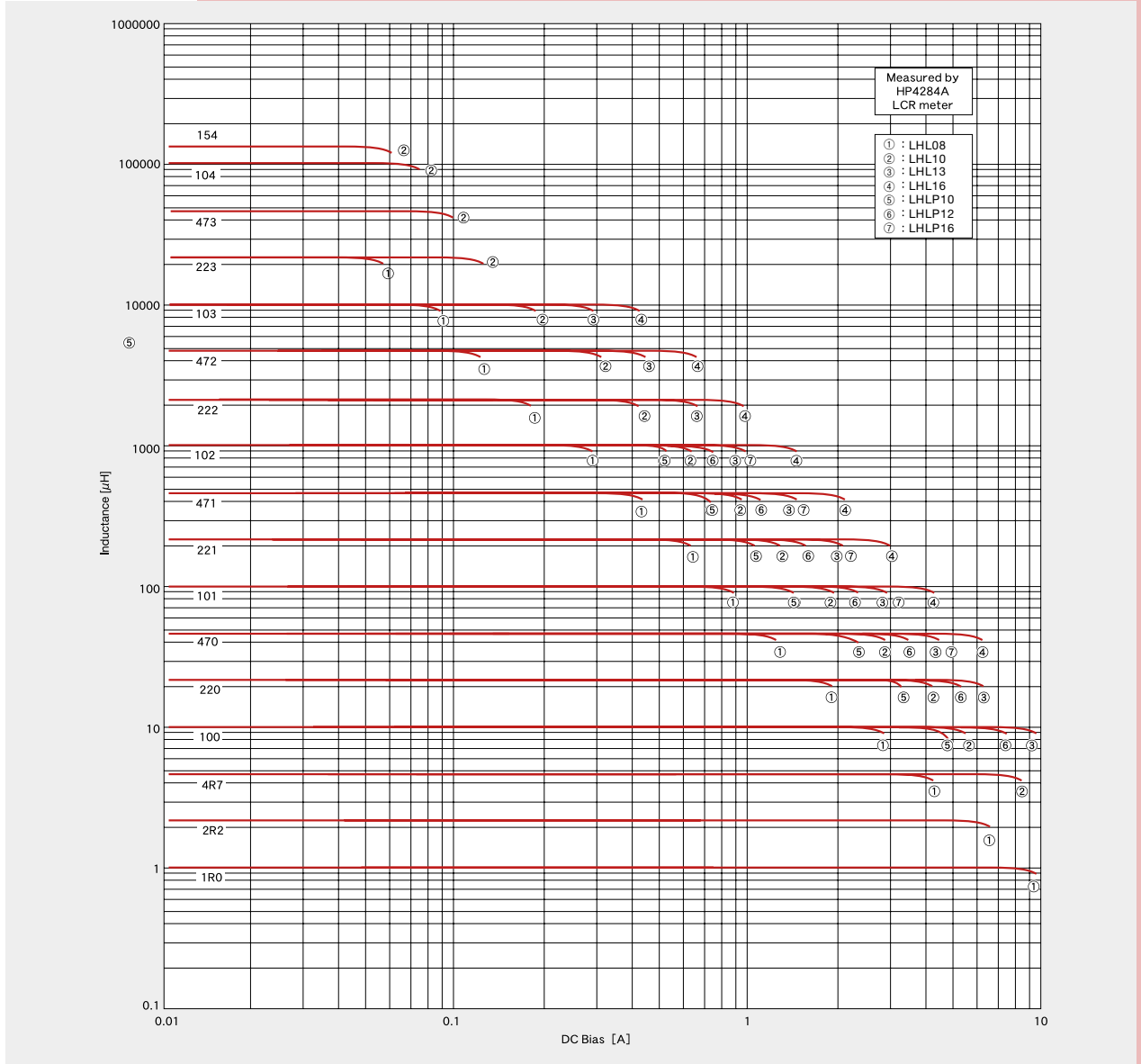

Temperature characteristics

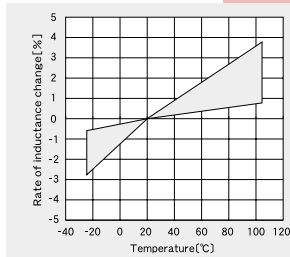

Q-vs-Frequency characteristics

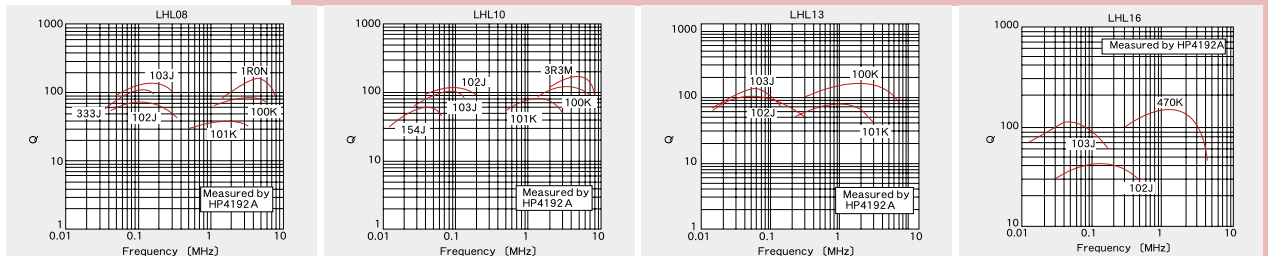

\* This catalog contains the typical specification only due to the limitation of space. When you consider the purchase of our products, please check our specification. For details of each product (characteristics graph, reliability information, precautions for use, and so on), see our Web site (<http://www.ty-top.com/>) or CD catalogs.

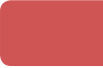

---

\* This catalog contains the typical specification only due to the limitation of space. When you consider the purchase of our products, please check our specification.  
For details of each product (characteristics graph, reliability information, precautions for use, and so on), see our Web site (<http://www.ty-top.com/>) or CD catalogs.

**PACKAGING**

① Minimum Quantity

Type (EIA)	Standard quantity (pcs)		
	Box	Bulk	Taped
LHL 08	—	100	1000
LHL 10	—	50	500
LHL 13	—	25	500
LHL 16	500	—	250
LHLP10	500	—	200
LHLP12NB	300	—	—
LHLP16NB	200	—	—

② Bulk dimensions

● LHL08~16

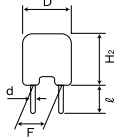

Type	Dimensions				
	φD (max)	H <sub>2</sub> (max)	F*	ℓ	φd
LHL08	9.0 (0.354)	9.5 (0.374)	5.0±1.0 (0.197±0.039)	5.0±1.0 (0.197±0.039)	0.6±0.05 (0.024±0.002)
LHL10	11.0 (0.433)	14.0 (0.551)	5.0±1.0 (0.197±0.039)	5.0±1.0 (0.197±0.039)	0.6±0.05 (0.024±0.002)
LHL13	14.0 (0.551)	17.0 (0.669)	7.5±1.0 (0.295±0.039)	5.0±1.0 (0.197±0.039)	0.8±0.05 (0.031±0.002)
LHL16	17.0 (0.669)	21.0 (0.827)	7.5±1.0 (0.295±0.039)	5.0±1.0 (0.197±0.039)	0.8±0.05 (0.031±0.002)

\* Measured at the base of the leads.

Unit : mm (inch)

● LHLP10~16

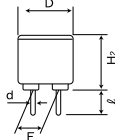

Type	Dimensions				
	φD (max)	H <sub>2</sub> (max)	F*	ℓ	φd
LHLP10	11.0 (0.433)	11.0 (0.433)	5.0±1.0 (0.197±0.039)	5.0±1.0 (0.197±0.039)	0.6±0.05 (0.024±0.004)
LHLP12	13.0 (0.512)	16.0 (0.624)	5.0±1.0 (0.197±0.039)	5.0±1.0 (0.197±0.039)	0.6±0.05 (0.024±0.004)
LHLP16	17.0 (0.669)	19.0 (0.741)	7.5±1.0 (0.295±0.039)	5.0±1.0 (0.197±0.039)	0.8±0.05 (0.031±0.004)

\* Measured at the base of the leads.

Unit : mm (inch)

● LHL08~16

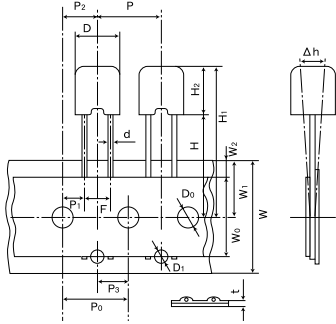

	LHL08	LHL10	LHL13	LHL16
D	φ9.0 max (φ0.354 max)	φ11.0 max (φ0.433 max)	φ14.0 max (φ0.551 max)	φ17.0 max (φ0.669 max)
H <sub>1</sub>	30.5 max (1.20 max)	34.0 max (1.34 max)	37.0 max (1.46 max)	41.0 max (1.61 max)
H	18.0 <sup>+2.0</sup> <sub>-0.0</sub> (0.709 <sup>+0.079</sup> <sub>-0.000</sub> )	18.0 <sup>+2.0</sup> <sub>-0.0</sub> (0.709 <sup>+0.079</sup> <sub>-0.000</sub> )	18.0 <sup>+2.0</sup> <sub>-0.0</sub> (0.709 <sup>+0.079</sup> <sub>-0.000</sub> )	18.0 <sup>+2.0</sup> <sub>-0.0</sub> (0.709 <sup>+0.079</sup> <sub>-0.000</sub> )
H <sub>2</sub>	9.5 max (0.374 max)	14.0 max (0.551 max)	17.0 max (0.669 max)	21.0 max (0.827 max)

	LHL08	LHL10	LHL13	LHL16
P	12.7±1.0 (0.500±0.039)	12.7±1.0 (0.500±0.039)	15.0±1.0 (0.591±0.039)	30.0±1.0 (1.18±0.039)
P <sub>0</sub>	12.7±0.3 <sup>#1</sup> (0.500±0.012)	12.7±0.3 <sup>#1</sup> (0.500±0.012)	15.0±0.3 <sup>#1</sup> (0.591±0.012)	15.0±0.3 <sup>#1</sup> (0.591±0.012)
P <sub>1</sub>	3.85±0.7 (0.152±0.028)	3.85±0.7 (0.152±0.028)	3.75±0.7 (0.148±0.028)	3.75±0.7 (0.148±0.028)
P <sub>2</sub>	6.35±1.3 (0.250±0.051)	6.35±1.3 (0.250±0.051)	7.50±1.3 (0.295±0.051)	7.50±1.3 (0.295±0.051)
F	5.0 <sup>+0.8</sup> <sub>-0.2</sub> (0.197 <sup>+0.031</sup> <sub>-0.008</sub> )	5.0 <sup>+0.8</sup> <sub>-0.2</sub> (0.197 <sup>+0.031</sup> <sub>-0.008</sub> )	7.50 <sup>+0.8</sup> <sub>-0.2</sub> (0.295 <sup>+0.031</sup> <sub>-0.008</sub> )	7.50±0.5 (0.295±0.020)
h	0.0±2.0 (0.0±0.079)	0.0±2.0 (0.0±0.079)	0.0±2.0 (0.0±0.079)	0.0±2.0 (0.0±0.079)
W	18.0 <sup>+1.0</sup> <sub>-0.5</sub> (0.709 <sup>+0.039</sup> <sub>-0.020</sub> )	18.0 <sup>+1.0</sup> <sub>-0.5</sub> (0.709 <sup>+0.039</sup> <sub>-0.020</sub> )	18.0 <sup>+1.0</sup> <sub>-0.5</sub> (0.709 <sup>+0.039</sup> <sub>-0.020</sub> )	18.0 <sup>+1.0</sup> <sub>-0.5</sub> (0.709 <sup>+0.039</sup> <sub>-0.020</sub> )
W <sub>0</sub>	12.5 min (0.492 min)	12.5 min (0.492 min)	12.5 min (0.492 min)	12.5 min (0.492 min)
W <sub>1</sub>	9.0±0.5 (0.354±0.020)	9.0±0.5 (0.354±0.020)	9.0±0.5 (0.354±0.020)	9.0±0.5 (0.354±0.020)
W <sub>2</sub>	3.0 max <sup>#2</sup> (0.118 max)	3.0 max <sup>#2</sup> (0.118 max)	3.0 max <sup>#2</sup> (0.118 max)	3.0 max <sup>#2</sup> (0.118 max)
D <sub>0</sub>	φ4.0±0.2 (φ0.158±0.008)	φ4.0±0.2 (φ0.158±0.008)	φ4.0±0.2 (φ0.158±0.008)	φ4.0±0.2 (φ0.158±0.008)
φd	φ0.6±0.05 (φ0.024±0.002)	φ0.6±0.05 (φ0.024±0.002)	φ0.8±0.05 (φ0.031±0.002)	φ0.8±0.05 (φ0.031±0.002)
t	0.6±0.3 (0.024±0.012)	0.6±0.3 (0.024±0.012)	0.6±0.3 (0.024±0.012)	0.6±0.3 (0.024±0.012)
D <sub>1</sub>	φ1.8 (0.071)	φ1.8 (0.071)	φ1.8 (0.071)	—
P <sub>3</sub>	6.35 (0.25)	6.35 (0.25)	7.50 (0.25)	—

\*1 Accumulated error for 20 pitches is 1mm.

Unit : mm (inch)

\*2 Bonding tape must not protrude from the base tape.

● LHLP10TB

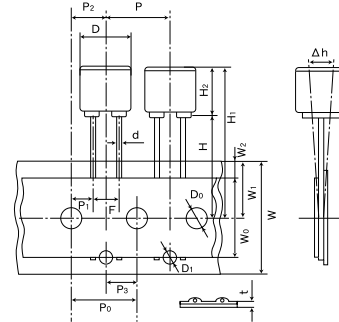

Type	Symbol	Dimensions	Symbol	Dimensions
LHLP10	D	φ11.0 max (φ0.433 max)	W	18.0 <sup>+1.0</sup> <sub>-0.5</sub> (0.709 <sup>+0.039</sup> <sub>-0.020</sub> )
	H <sub>1</sub>	32.0 max (1.26 max)	W <sub>0</sub>	12.5 min (0.492 min)
	H	18.0 <sup>+2.0</sup> <sub>-0.0</sub> (0.709 <sup>+0.079</sup> <sub>-0.000</sub> )	W <sub>1</sub>	9.0±0.5 (0.354±0.020)
	H <sub>2</sub>	11.0 max (0.433 max)	W <sub>2</sub>	3.0 max <sup>#2</sup> (0.118 max)
	P	12.7±1.0 (0.500±0.039)	D <sub>0</sub>	φ4.0±0.2 (φ0.158±0.008)
	P <sub>0</sub>	12.7±0.3 <sup>#1</sup> (0.500±0.012)	φd	φ0.6±0.05 (φ0.024±0.002)
	P <sub>1</sub>	3.85±0.7 (0.152±0.028)	t	0.6±0.3 (0.024±0.012)
	P <sub>2</sub>	6.35±1.3 (0.250±0.051)	D <sub>1</sub>	φ1.8 (0.071)
	F	5.0 <sup>+0.8</sup> <sub>-0.2</sub> (0.197 <sup>+0.031</sup> <sub>-0.008</sub> )	P <sub>3</sub>	6.35 (0.25)
	h	0.0±2.0 (0.0±0.079)		

\*1 Accumulated error for 20 pitches is 1mm.

\*2 Bonding tape must not protrude from the base tape.

\* This catalog contains the typical specification only due to the limitation of space. When you consider the purchase of our products, please check our specification. For details of each product (characteristics graph, reliability information, precautions for use, and so on), see our Web site (<http://www.ty-top.com/>) or CD catalogs.

# HIGH CURRENT LEADED INDUCTORS



WAVE

## FEATURES

- CAL45 is high current type, and has superior DC bias characteristics.
- Wide selection of configurations including axial leaded, formed radial leads to meet most manufacturing needs.
- LHLC08/LHLC10 series which are encapsulated in a resin housing, are radial leaded inductor for high current applications.

## APPLICATIONS

- For DC/DC converter (LCD TV, PDP TV, CTV, DVD etc.)

## OPERATING TEMP.

- -25°C~105°C (Including self-generated heat)

## ORDERING CODE

[CA type]

C A L  $\triangle$  4 5 T B 1 0 0 K  $\circ$   $\circ$   $\circ$   $\circ$   $\circ$

<b>1</b> Type	<b>2</b> Product Specification	<b>3</b> Dimensions (L×D) [mm] max	<b>4</b> Lead Configurations	<b>5</b> Nominal Inductance ( $\mu$ H)	<b>6</b> Inductance Tolerance [%]	<b>7</b> Internal code
CA High current axial leaded inductor	L $\triangle$ Standard type $\triangle$ =Blank space	45 8.0×4.4	TB Axial lead (52mm lead space/ ammo pack) VB Formed lead/ ammo pack	example 1R5 1.5 120 12 *R=decimal point	K $\pm$ 10	$\triangle\triangle\triangle\triangle$ Standard product $\triangle$ = Blank space

[LH type]

L H  $\triangle$  L C 0 8 T B 1 0 1 K  $\circ$   $\circ$   $\circ$

<b>1</b> Type	<b>2</b> Product Specification	<b>3</b> Dimensions [mm] max	<b>4</b> Packing Code	<b>5</b> Nominal Inductance ( $\mu$ H)	<b>6</b> Inductance Tolerance [%]	<b>7</b> Internal code
LH $\triangle$ Radial leaded inductor $\triangle$ =Blank space	LC High current type	08 9.0 10 11.0	NB Bulk TB Ammo packing	example 1R5 1.5 120 12 102 1000 *R=decimal point	J $\pm$ 5 K $\pm$ 10 M $\pm$ 20	$\triangle\triangle\triangle$ Standard product $\triangle$ = Blank space

## EXTERNAL DIMENSIONS/STANDARD QUANTITY

[CA type]

Type	Fig.	Dimensions [mm] (inch)			Taped		Standard Quantity (pcs)	
		L	$\phi$ D	$\phi$ d	Straight	Formed	Bulk	Taped
CAL45		8.0max (0.315max)	4.4max (0.173max)	0.65±0.05 (0.026±0.002)	TB	VB	—	Axial lead 2000 Formed lead 1500

Unit : mm (inch)

[LH type]

Type	Fig.	D	H <sub>2</sub>	$\ell$	F	$\phi$ d	Standard Quantity (pcs)	
							Bulk	Taped
LHLC08		9.0max (0.354max)	9.5max (0.374max)	5.0±1.0 (0.197±0.039)	5.0±1.0 (0.197±0.039)	0.6±0.05 (0.024±0.002)	100	1000
LHLC10		11.0max (0.433max)	14.0max (0.551max)	5.0±1.0 (0.197±0.039)	5.0±1.0 (0.197±0.039)	0.6±0.05 (0.024±0.002)	50	500

Unit : mm (inch)

## AVAILABLE INDUCTANCE RANGE

Range	Type	CAL45		LHLC08		LHLC10	
		Rdc max[ $\Omega$ ]	I <sub>max</sub> [A]	Rdc max[ $\Omega$ ]	I <sub>max</sub> [A]	Rdc max[ $\Omega$ ]	I <sub>max</sub> [A]
0.1 $\mu$		0.036	1.0 $\mu$	0.013	1.0 $\mu$		
1.0 $\mu$		0.14	1.7	0.041	2.9	0.034	3.3 $\mu$
10 $\mu$		1.2	0.59	0.32	1.0	0.18	3.6
100 $\mu$		13.2	0.17	2.7	0.35	1.8	1.5
1.0m							0.48
10m				32.0	0.11	19.0	0.14
100m						240.0	0.038
							150m

\* This catalog contains the typical specification only due to the limitation of space. When you consider the purchase of our products, please check our specification. For details of each product (characteristics graph, reliability information, precautions for use, and so on), see our Web site (<http://www.ty-top.com/>) or CD catalogs.

**PART NUMBERS**

**CAL45**

Ordering code	EHS (Environmental Hazardous Substances)	Inductance [ $\mu$ H]	Inductance Tolerance	Q (reference)	Self-resonant frequency [MHz] (reference)	Measuring frequency [MHz]	DC Resistance [ $\Omega$ ] (max.)	Rated current ※)			
								Saturation current I <sub>dc1</sub> [mA]	Temperature rise current I <sub>dc2</sub>		
CAL 45 ○ 1R0K	RoHS	1.0	±10%	30	350	7.96	0.036	5600	3300		
CAL 45 ○ 1R2K	RoHS	1.2			300		0.039	5000	3200		
CAL 45 ○ 1R5K	RoHS	1.5			300		0.041	4400	3000		
CAL 45 ○ 1R8K	RoHS	1.8			200		0.048	4100	2800		
CAL 45 ○ 2R2K	RoHS	2.2			200		0.054	3900	2700		
CAL 45 ○ 2R7K	RoHS	2.7			70		0.058	3500	2500		
CAL 45 ○ 3R3K	RoHS	3.3			70		0.066	3100	2400		
CAL 45 ○ 3R9K	RoHS	3.9			40		0.072	3000	2300		
CAL 45 ○ 4R7K	RoHS	4.7			40		0.079	2800	2200		
CAL 45 ○ 5R6K	RoHS	5.6			35		0.089	2500	2100		
CAL 45 ○ 6R8K	RoHS	6.8			35		0.097	2200	2000		
CAL 45 ○ 8R2K	RoHS	8.2			30		0.110	2000	1900		
CAL 45 ○ 100K	RoHS	10			40		25	2.52	0.14	1700	1800
CAL 45 ○ 120K	RoHS	12					25		0.17	1600	1450
CAL 45 ○ 150K	RoHS	15					25		0.19	1400	1430
CAL 45 ○ 180K	RoHS	18					20		0.24	1250	1300
CAL 45 ○ 220K	RoHS	22					20		0.28	1200	1220
CAL 45 ○ 270K	RoHS	27					17		0.33	1100	1130
CAL 45 ○ 330K	RoHS	33		15		0.37	1000		1080		
CAL 45 ○ 390K	RoHS	39		13		0.47	920		900		
CAL 45 ○ 470K	RoHS	47		13		0.52	890		870		
CAL 45 ○ 560K	RoHS	56		11		0.75	790		710		
CAL 45 ○ 680K	RoHS	68		10		0.78	700		700		
CAL 45 ○ 820K	RoHS	82		9		0.92	620		640		
CAL 45 ○ 101K	RoHS	100		40		9	0.796		1.2	590	630
CAL 45 ○ 121K	RoHS	120		50		7			1.6	550	490
CAL 45 ○ 151K	RoHS	150		7		1.8			490	470	
CAL 45 ○ 181K	RoHS	180		60		5			2.3	420	450
CAL 45 ○ 221K	RoHS	220		80		5			2.9	370	425
CAL 45 ○ 271K	RoHS	270		5		3.4			350	355	
CAL 45 ○ 331K	RoHS	330		70	4.5	3.6		320	330		
CAL 45 ○ 391K	RoHS	390			4	4.9		290	280		
CAL 45 ○ 471K	RoHS	470		80	4	6.3		270	240		
CAL 45 ○ 561K	RoHS	560			3	7.0		250	240		
CAL 45 ○ 681K	RoHS	680			3	7.8		240	220		
CAL 45 ○ 821K	RoHS	820			2.5	11.0		220	210		
CAL 45 ○ 102K	RoHS	1000			2.5	13.2		190	170		
CAL 45 ○ 122K	RoHS	1200			2	17		170	150		
CAL 45 ○ 152K	RoHS	1500		2	22	150		140			
CAL 45 ○ 182K	RoHS	1800		1.5	27	140		120			
CAL 45 ○ 222K	RoHS	2200		1.5	36	130		110			
CAL 45 ○ 272K	RoHS	2700		1.2	45	110		90			
CAL 45 ○ 332K	RoHS	3300		1.2	65	100	75				
CAL 45 ○ 392K	RoHS	3900		1	69	95	70				
CAL 45 ○ 472K	RoHS	4700		1	80	90	65				
CAL 45 ○ 562K	RoHS	5600		1	90	90	60				
CAL 45 ○ 682K	RoHS	6800		1	100	80	60				
CAL 45 ○ 822K	RoHS	8200		0.7	125	75	50				
CAL 45 ○ 103K	RoHS	10000		30	0.6	0.0796	155	65	45		

○ Please specify the Lead configuration code.

※) The saturation current value (I<sub>dc1</sub>) is the DC current value having inductance decrease down to 10%. (at 20°C)

※) The temperature rise current value (I<sub>dc2</sub>) is the DC current value having temperature increase up to 40°C. (at 20°C)

※) The rated current is the DC current value that satisfies both of current value saturation current value and temperature rise current value.

**LHLC08**

Ordering code	EHS (Environmental Hazardous Substances)	Inductance [ $\mu$ H]	Inductance Tolerance	Q (min.)	Self-resonant frequency [MHz] (min.)	DC Resistance [ $\Omega$ ] (max.)	Rated current [A] (max.)	Measuring frequency [MHz]			
LH LC08 □ □ 1R0N	RoHS	1.0	±30%	40	76	0.013	5.4	7.96			
LH LC08 □ □ 1R5M	RoHS	1.5			65	0.014	5.2				
LH LC08 □ □ 2R2M	RoHS	2.2			56	0.017	4.8				
LH LC08 □ □ 2R7M	RoHS	2.7			48	0.019	4.2				
LH LC08 □ □ 3R3M	RoHS	3.3			41	0.021	3.8				
LH LC08 □ □ 3R9M	RoHS	3.9			33	0.024	3.7				
LH LC08 □ □ 4R7M	RoHS	4.7			30	0.025	3.6				
LH LC08 □ □ 5R6M	RoHS	5.6			23	0.028	3.5				
LH LC08 □ □ 6R8M	RoHS	6.8			21	0.030	3.4				
LH LC08 □ □ 8R2M	RoHS	8.2			19	0.034	3.0				
LH LC08 □ □ 100K	RoHS	10			±10%	65	17		0.041	2.9	2.52
LH LC08 □ □ 120K	RoHS	12					16		0.044	2.8	
LH LC08 □ □ 150K	RoHS	15					13		0.053	2.6	
LH LC08 □ □ 180K	RoHS	18					50		12	0.060	
LH LC08 □ □ 220K	RoHS	22	11	0.068				2.3			

To next page

\* This catalog contains the typical specification only due to the limitation of space. When you consider the purchase of our products, please check our specification. For details of each product (characteristics graph, reliability information, precautions for use, and so on), see our Web site (<http://www.ty-top.com/>) or CD catalogs.

**PART NUMBERS**

Ordering code	EHS (Environmental Hazardous Substances)	Inductance [ $\mu$ H]	Inductance Tolerance	Q (min.)	Self-resonant frequency (MHz) (min.)	DC Resistance [ $\Omega$ ] (max.)	Rated current [A] (max.)	Measuring frequency [MHz]	
LH LC08□□270K	RoHS	27	±10%	50	10	0.091	2.0	2.52	
LH LC08□□330K	RoHS	33			8.8	0.10	1.9		
LH LC08□□390K	RoHS	39			8.4	0.12	1.7		
LH LC08□□470K	RoHS	47			8.2	0.15	1.5		
LH LC08□□560K	RoHS	56			7.9	0.17	1.4		
LH LC08□□680K	RoHS	68			7.0	0.20	1.3		
LH LC08□□820K	RoHS	82		35	6.5	0.22	1.2	0.796	
LH LC08□□101K	RoHS	100			25	5.7	0.32		1.0
LH LC08□□121K	RoHS	120				5.2	0.36		0.96
LH LC08□□151K	RoHS	150			20	4.7	0.41		0.88
LH LC08□□181K	RoHS	180				4.2	0.66		0.71
LH LC08□□221K	RoHS	220			35	3.7	0.73		0.66
LH LC08□□271K	RoHS	270		3.5		0.85	0.63		
LH LC08□□331K	RoHS	330		25	3.2	0.97	0.59		
LH LC08□□391K	RoHS	390			2.9	1.1	0.55		
LH LC08□□471K	RoHS	470		20	2.4	1.3	0.49		
LH LC08□□561K	RoHS	560			2.2	1.5	0.47		
LH LC08□□681K	RoHS	680		25	2.0	1.8	0.44		
LH LC08□□821K	RoHS	820	30		1.6	2.3	0.38		
LH LC08□□102J	RoHS	1000	±5%	55	1.5	2.7	0.35	0.252	
LH LC08□□122J	RoHS	1200		45	1.4	3.2	0.31		
LH LC08□□152J	RoHS	1500		55	1.3	4.1	0.29		
LH LC08□□182J	RoHS	1800			1.2	4.8	0.26		
LH LC08□□222J	RoHS	2200			1.1	5.6	0.23		
LH LC08□□272J	RoHS	2700			1.0	7.5	0.21		
LH LC08□□332J	RoHS	3300			0.85	8.5	0.19		
LH LC08□□392J	RoHS	3900			0.78	9.7	0.18		
LH LC08□□472J	RoHS	4700		65	0.68	14	0.16		
LH LC08□□562J	RoHS	5600			0.62	16	0.15		
LH LC08□□682J	RoHS	6800		60	0.61	18	0.14		
LH LC08□□822J	RoHS	8200			0.60	20	0.13		
LH LC08□□103J	RoHS	10000		60	0.48	32	0.11		
LH LC08□□123J	RoHS	12000			0.44	36	0.084		
LH LC08□□153J	RoHS	15000			0.35	62	0.068		
LH LC08□□183J	RoHS	18000			0.30	72	0.066		
LH LC08□□223J	RoHS	22000			0.28	82	0.057		
LH LC08□□273J	RoHS	27000			0.25	90	0.054		
LH LC08□□333J	RoHS	33000	0.23	100	0.053				

□ Please specify the packaging code. (TB: Taping, NB: Bulk)

**LHLC10**

Ordering code	EHS (Environmental Hazardous Substances)	Inductance [ $\mu$ H]	Inductance Tolerance	Q (min.)	Self-resonant frequency (MHz) (min.)	DC Resistance [ $\Omega$ ] (max.)	Rated current [A] (max.)	Measuring frequency [MHz]
LH LC10□□3R3M	RoHS	3.3	±20%	50	46	0.019	5.0	7.96
LH LC10□□3R9M	RoHS	3.9			40	0.022	4.8	
LH LC10□□4R7M	RoHS	4.7			38	0.024	4.7	
LH LC10□□5R6M	RoHS	5.6			34	0.025	4.5	
LH LC10□□6R8M	RoHS	6.8			30	0.028	4.1	
LH LC10□□8R2M	RoHS	8.2			24	0.031	3.9	
LH LC10□□100K	RoHS	10	90	19	0.034	3.6	2.52	
LH LC10□□120K	RoHS	12		16	0.038	3.4		
LH LC10□□150K	RoHS	15		12	0.042	3.2		
LH LC10□□180K	RoHS	18		9.2	0.046	3.0		
LH LC10□□220K	RoHS	22		8.6	0.061	2.8		
LH LC10□□270K	RoHS	27		7.1	0.069	2.7		
LH LC10□□330K	RoHS	33	60	6.8	0.078	2.6	0.796	
LH LC10□□390K	RoHS	39		6.7	0.085	2.4		
LH LC10□□470K	RoHS	47		50	6.2	0.093		2.3
LH LC10□□560K	RoHS	56			5.2	0.10		2.1
LH LC10□□680K	RoHS	68		40	4.6	0.12		2.0
LH LC10□□820K	RoHS	82			4.7	0.13		1.8
LH LC10□□101K	RoHS	100	3.8		0.18	1.5		
LH LC10□□121K	RoHS	120	3.2		0.25	1.3		
LH LC10□□151K	RoHS	150	2.9		0.29	1.2		
LH LC10□□181K	RoHS	180	2.6		0.40	1.0		
LH LC10□□221K	RoHS	220	30	2.3	0.44	0.95		
LH LC10□□271K	RoHS	270		2.1	0.50	0.90		
LH LC10□□331K	RoHS	330	±10%	30	2.0	0.56	0.86	0.796
LH LC10□□391K	RoHS	390			1.8	0.62	0.75	
LH LC10□□471K	RoHS	470			1.7	0.84	0.65	
LH LC10□□561K	RoHS	560			1.5	0.93	0.61	
LH LC10□□681K	RoHS	680			1.4	1.0	0.57	
LH LC10□□821K	RoHS	820			1.3	1.4	0.50	

To next page

\* This catalog contains the typical specification only due to the limitation of space. When you consider the purchase of our products, please check our specification. For details of each product (characteristics graph, reliability information, precautions for use, and so on), see our Web site (<http://www.ty-top.com/>) or CD catalogs.



**PART NUMBERS**

Ordering code	EHS (Environmental Hazardous Substances)	Inductance [ $\mu$ H]	Inductance Tolerance	Q (min.)	Self-resonant frequency [MHz] (min.)	DC Resistance [ $\Omega$ ] (max.)	Rated current [A] (max.)	Measuring frequency [MHz]	
LH LC10□□102J	RoHS	1000	±5%	50	1.2	1.8	0.48	0.252	
LH LC10□□122J	RoHS	1200			0.87	2.3	0.40		
LH LC10□□152J	RoHS	1500			0.83	2.7	0.37		
LH LC10□□182J	RoHS	1800			0.75	3.0	0.36		
LH LC10□□222J	RoHS	2200			0.70	3.9	0.32		
LH LC10□□272J	RoHS	2700			0.67	4.3	0.30		
LH LC10□□332J	RoHS	3300			0.56	5.8	0.26		
LH LC10□□392J	RoHS	3900			0.54	6.4	0.25		
LH LC10□□472J	RoHS	4700			0.49	7.1	0.24		
LH LC10□□562J	RoHS	5600			0.41	9.0	0.21		
LH LC10□□682J	RoHS	6800			0.38	10	0.20		
LH LC10□□822J	RoHS	8200			0.36	12	0.18		
LH LC10□□103J	RoHS	10000			0.29	19	0.14		L:1kHz Q:0.0796
LH LC10□□123J	RoHS	12000			0.27	21	0.13		
LH LC10□□153J	RoHS	15000			0.24	34	0.11		
LH LC10□□183J	RoHS	18000			0.21	38	0.10		
LH LC10□□223J	RoHS	22000			0.20	43	0.095		
LH LC10□□273J	RoHS	27000			0.15	67	0.076		
LH LC10□□333J	RoHS	33000		0.14	76	0.068			
LH LC10□□393J	RoHS	39000		0.13	84	0.065			
LH LC10□□473J	RoHS	47000		0.12	96	0.061			
LH LC10□□563J	RoHS	56000		0.10	170	0.045	L:1kHz Q:0.0252		
LH LC10□□683J	RoHS	68000		0.095	200	0.043			
LH LC10□□823J	RoHS	82000		0.088	210	0.041			
LH LC10□□104J	RoHS	100000		0.085	240	0.038			
LH LC10□□124J	RoHS	120000		0.070	260	0.037			
LH LC10□□154J	RoHS	150000		0.069	300	0.035			

□ Please specify the packaging code. (TB: Taping, NB: Bulk)

**FERRITE PRODUCTS**

**ELECTRICAL CHARACTERISTICS**

**DC Bias characteristics**

(Measured by HP4285A)

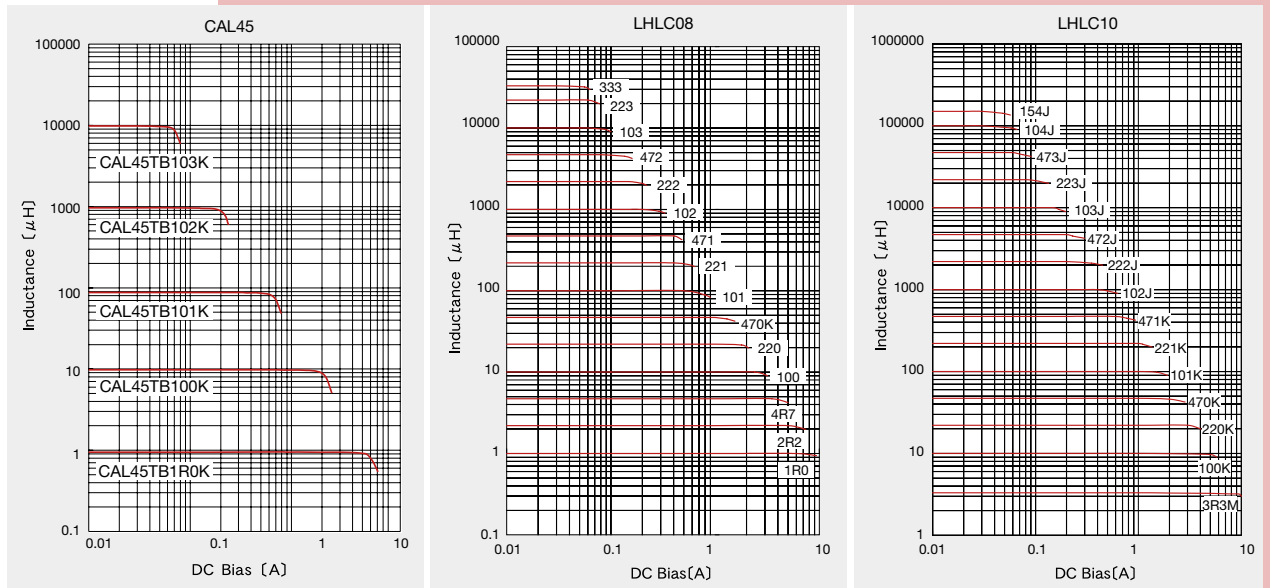

\* This catalog contains the typical specification only due to the limitation of space. When you consider the purchase of our products, please check our specification. For details of each product (characteristics graph, reliability information, precautions for use, and so on), see our Web site (<http://www.ty-top.com/>) or CD catalogs.

# PACKAGING

## ① Minimum Quantity

Type (EIA)	Standard quantity (pcs)					
	Bulk	Taped				
CAL45	—	<table border="1"> <tr> <td>Axial lead</td> <td>2000</td> </tr> <tr> <td>Formed lead</td> <td>1500</td> </tr> </table>	Axial lead	2000	Formed lead	1500
Axial lead	2000					
Formed lead	1500					
LHLC08	100	1000				
LHLC10	50	500				

## ② Taping dimensions

- CAL 45 TB (a : 52mm lead space)  
(2.05 inches)

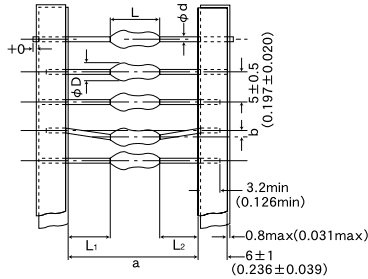

Type	Dimensions						Minimum insertion pitch
	$\phi D$	L	a	b	$ L_1 - L_2 $	$\phi d$	
CAL45	4.4max (0.173max)	8.0max (0.315max)	52 <sup>+2</sup> <sub>-1</sub> (2.05 <sup>+0.079</sup> <sub>-0.039</sub> )	1.2max (0.047max)	1.0max (0.039max)	0.65±0.05 (0.026±0.002)	10.0 (0.394)

Unit : mm (inch)

## ③ Bulk dimensions

Type	Dimensions					
	$\phi D$ (max)	H <sub>2</sub> (max)	F*	$\ell$	$\phi d$	
LHLC08	9.0 (0.354)	9.5 (0.374)	5.0±1.0 (0.197±0.039)	5.0±1.0 (0.197±0.039)	0.6±0.05 (0.024±0.002)	
LHLC10	11.0 (0.433)	14.0 (0.551)	5.0±1.0 (0.197±0.039)	5.0±1.0 (0.197±0.039)	0.6±0.05 (0.024±0.002)	

\*Measured at the base of the leads.

Unit : mm (inch)

- CAL 45VB

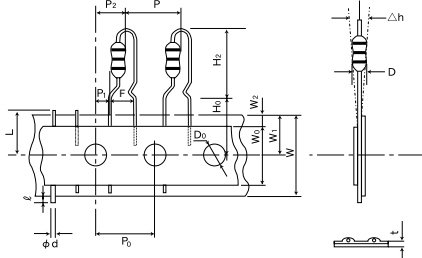

Type	Symbol	Dimensions	Symbol	Dimensions
CAL 45	D	$\phi 4.4\text{max}$	W	18.0 <sup>+1.0</sup> <sub>-0.5</sub> (0.709 <sup>+0.039</sup> <sub>-0.020</sub> )
	H <sub>2</sub>	14.0max (0.551max)	W <sub>0</sub>	12.5min (0.492min)
	H <sub>0</sub>	16.0±1.0 (0.630±0.039)	W <sub>1</sub>	9.0 <sup>+0.75</sup> <sub>-0.5</sub> (0.354 <sup>+0.030</sup> <sub>-0.020</sub> )
	P	12.7±1.0 (0.500±0.039)	W <sub>2</sub>	3.0max <sup>※2</sup> (0.118max)
	P <sub>0</sub>	12.7±0.3 <sup>※1</sup> (0.500±0.012)	$\ell$	2.0max (0.079max)
	P <sub>1</sub>	3.85±0.7 (0.152±0.028)	D <sub>0</sub>	$\phi 4.0\pm 0.2$ ( $\phi 0.157\pm 0.008$ )
	P <sub>2</sub>	6.35±1.3 (0.250±0.051)	$\phi d$	$\phi 0.65\pm 0.05$ ( $\phi 0.026\pm 0.002$ )
	F	5.0±1.0 (0.197±0.039)	L	11.0max (0.433max)
	$\Delta h$	0.0±2.0 (0.0±0.079)	t	0.9max (0.035max)

Unit : mm (inch)

※1 Accumulated error for 20 pitches is ± 1mm.

※2 Bonding tape must not protrude from the base tape.

- LHLC08, LHLC10

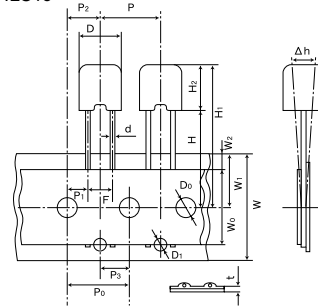

	LHLC08	LHLC10
D	$\phi 9.0\text{max}$ ( $\phi 0.354\text{max}$ )	$\phi 11.0\text{max}$ ( $\phi 0.433\text{max}$ )
H <sub>1</sub>	30.5max (1.20max)	34.0max (1.34max)
H	18.0 <sup>+2.0</sup> <sub>-0.0</sub> (0.709 <sup>+0.079</sup> <sub>-0.000</sub> )	18.0 <sup>+2.0</sup> <sub>-0.0</sub> (0.709 <sup>+0.079</sup> <sub>-0.000</sub> )
H <sub>2</sub>	9.5max (0.374max)	14.0max (0.551max)
P	12.7±1.0 (0.500±0.039)	12.7±1.0 (0.500±0.039)
P <sub>0</sub>	12.7±0.3 <sup>※1</sup> (0.500±0.012)	12.7±0.3 <sup>※1</sup> (0.500±0.012)
P <sub>1</sub>	3.85±0.7 (0.152±0.028)	3.85±0.7 (0.152±0.028)
P <sub>2</sub>	6.35±1.3 (0.250±0.051)	6.35±1.3 (0.250±0.051)
F	5.0 <sup>+0.8</sup> <sub>-0.2</sub> (0.197 <sup>+0.031</sup> <sub>-0.008</sub> )	5.0 <sup>+0.8</sup> <sub>-0.2</sub> (0.197 <sup>+0.031</sup> <sub>-0.008</sub> )
h	0.0±2.0 (0.0±0.079)	0.0±2.0 (0.0±0.079)
W	18.0 <sup>+1.0</sup> <sub>-0.5</sub> (0.709 <sup>+0.039</sup> <sub>-0.020</sub> )	18.0 <sup>+1.0</sup> <sub>-0.5</sub> (0.709 <sup>+0.039</sup> <sub>-0.020</sub> )
W <sub>0</sub>	12.5min (0.492min)	12.5min (0.492min)
W <sub>1</sub>	9.0±0.5 (0.354±0.020)	9.0±0.5 (0.354±0.020)
W <sub>2</sub>	3.0max <sup>※2</sup> (0.118max)	3.0max <sup>※2</sup> (0.118max)
D <sub>0</sub>	$\phi 4.0\pm 0.2$ ( $\phi 0.158\pm 0.008$ )	$\phi 4.0\pm 0.2$ ( $\phi 0.158\pm 0.008$ )
$\phi d$	$\phi 0.6\pm 0.05$ ( $\phi 0.024\pm 0.002$ )	$\phi 0.6\pm 0.05$ ( $\phi 0.024\pm 0.002$ )
t	0.6±0.3 (0.024±0.012)	0.6±0.3 (0.024±0.012)
D <sub>1</sub>	$\phi 1.8$ (0.071)	$\phi 1.8$ (0.071)
P <sub>3</sub>	6.35 (0.25)	6.35 (0.25)

※1 Accumulated error for 20 pitches is 1mm.

Unit : mm (inch)

※2 Bonding tape must not protrude from the base tape.

# LEADED FERRITE BEADS INDUCTORS



WAVE

## FEATURES

- Use of high loss ferrite material.
- Easy mounting on PC boards.
- Available in a wide range of values and configurations to suit most applications.

## APPLICATIONS

- Waveform correction of digital signals from digital equipment and absorption of high-frequency noise from data lines.

## OPERATING TEMP.

- -25°C~85°C

## ORDERING CODE

F B A 0 4 H A 4 5 0 B B ○ ○ ○

<b>1</b> Type	<b>2</b> Configuration	<b>3</b> Core Dimensions (mm)	<b>4</b> Material code	<b>5</b> Nominal Impedance	<b>6</b> Lead configuration (mm)	<b>7</b> Internal code
FB Ferrite Beads	A Axial lead R Radial lead	03 $\phi$ 2.5 04 $\phi$ 3.5 05 5.0 06 6.0 07 7.5	HA Refer to impedance curves for material difference VA	example 850 85 121 120 Excluding 03Type	AB Straight lead (26mm lead space) / ammo BB Straight lead (52mm lead space) / ammo KD Formed lead (10mm pitch) / bulk KE Formed lead (12.5mm pitch) / bulk KF Formed lead / bulk (15.0mm pitch) / bulk NA Lead (2.5mm pitch)/bulk (FBR) Straight lead / bulk (FBA) NB Formed lead (crimped) / bulk SA Straight lead (FBR05 type) / ammo SB Straight lead (FBR07 type) / ammo TB Straight lead (FBR07 type) / ammo UB Radial lead formed / ammo US Formed lead (crimped) / bulk VB Dual side lead formed (crimped) / ammo VS Formed lead / bulk	-00 Standard Products

## EXTERNAL DIMENSIONS/STANDARD QUANTITY

Type	Configurations				Dimensions		Standard Quantity (pcs)			
	Taping		Bulk		D	L	Type	Lead Configuration	Bulk	Taped Ammo
Straight	Formed	Straight	Formed							
FBA 03HA450 □ -00 03VA450 □ -00 04HA450 □ -00 04VA450 □ -00 04HA600 □ -00 04VA600 □ -00 04HA900 □ -00 04VA900 □ -00	AB, BB W: 26.52 (1.02, 2.05) P: 5.0 (0.197)	VB UB P: 12.7 (0.500)	NA	KD, KE, KF F: 10, 12.5, 15 (0.39, 0.492, 0.591) VS US F: 5.0 (0.197)	2.5±0.2 (0.098±0.008)	4.5±0.3 (0.177±0.012)	FBA03	NA, KD, US	1000	—
	AB, BB W: 26.52 (1.02, 2.05) P: 5.0 (0.197)	VB UB P: 12.7 (0.500)	NA	KD, KE, KF F: 10, 12.5, 15 (0.39, 0.492, 0.591) VS US F: 5.0 (0.197)	3.5±0.2 (0.138±0.008)	4.5±0.3 (0.177±0.012)		NA, KD, US	1000	—
	AB, BB W: 26.52 (1.02, 2.05) P: 5.0 (0.197)	VB P: 12.7 (0.500)	NA	KD, KE, KF F: 10, 12.5, 15 (0.39, 0.492, 0.591) VS	3.5±0.2 (0.138±0.008)	6.0 <sup>+0.5</sup> <sub>-0</sub> (0.236±0.020)		KE, KF, VS	500	—
	AB, BB W: 26.52 (1.02, 2.05) P: 5.0 (0.197)	VB P: 12.7 (0.500)	NA	KE, KF F: 12.5, 15 (0.492, 0.591) VS	3.5±0.2 (0.138±0.008)	9.0±0.5 (0.354±0.020)		UB, VB	—	3000
FBR 05VA121 □ -00 06HA850NA-00 06VA850NA-00 06HA121NA-00 06VA121NA-00 07HA850 □ -00 07VA850 □ -00 07HA121 □ -00 07VA121 □ -00	—	SA P: 12.7 (0.500)	—	NA F: 2.5 (0.098)	5.0 max. (0.197 max.)	7.5 (0.295)	FBR05	NA	1000	—
	—	—	—	NA F: 2.5 (0.098)	6.0±0.5 (0.236±0.020)	5.0 (0.197)		FBR06	NA	1000
	—	—	—	NA F: 2.5 (0.098)	7.0 (0.276)	7.0 (0.276)	NA		1000	—
	—	SB, TB P: 12.7 (0.500)	—	NB F: 5.0 (0.197)	7.5±0.5 (0.295±0.020)	5.5 (0.217)	FBR07		NB	1000
	—	—	—	—	—	7.5 (0.295)		SB	—	2000

□ Please specify the lead configuration code. Unit : mm (inch)  
Note: Lead diameter ( $\phi$ d) shall fall within a range of 0.65mm±0.05mm, FBR05, and FBR07 types however, will have a lead diameter ( $\phi$ d) range of 0.6mm±0.05mm.

\* This catalog contains the typical specification only due to the limitation of space. When you consider the purchase of our products, please check our specification. For details of each product (characteristics graph, reliability information, precautions for use, and so on), see our Web site (<http://www.ty-top.com/>) or CD catalogs.

**PART NUMBERS**

Ordering code	EHS (Environmental Hazardous Substances)	Impedance [Ω] min.	Measuring frequency [MHz]		Rated Current [A] max.		
			Material		Material		
			HA	VA	HA	VA	
FBA	03 △ 450 □ -00	RoHS	35.0	50	100	7.0	7.0
	04 △ 450 □ -00	RoHS	45.0	50	100	7.0	7.0
	04 △ 600 □ -00	RoHS	60.0	50	100	7.0	7.0
	04 △ 900 □ -00	RoHS	90.0	50	100	7.0	7.0
FBR	05 VA 121 □ -00	RoHS	120.0	-	100	-	7.0
	06 △ 850 NA -00	RoHS	85.0	50	100	7.0	7.0
	06 △ 121 NA -00	RoHS	120.0	50	100	7.0	7.0
	07 △ 850 □ -00	RoHS	85.0	50	100	7.0	7.0
	07 △ 121 □ -00	RoHS	120.0	50	100	7.0	7.0

△ Please specify material codes (HA,VA) and □ lead configuration code.

\* DC Resistance : 0.01Ω max., Insulation resistance : 1.0MΩ min.

**ELECTRICAL CHARACTERISTICS**

**IMPEDANCE-vs-FREQUENCY CHARACTERISTICS**

(Measured by HP4191A)

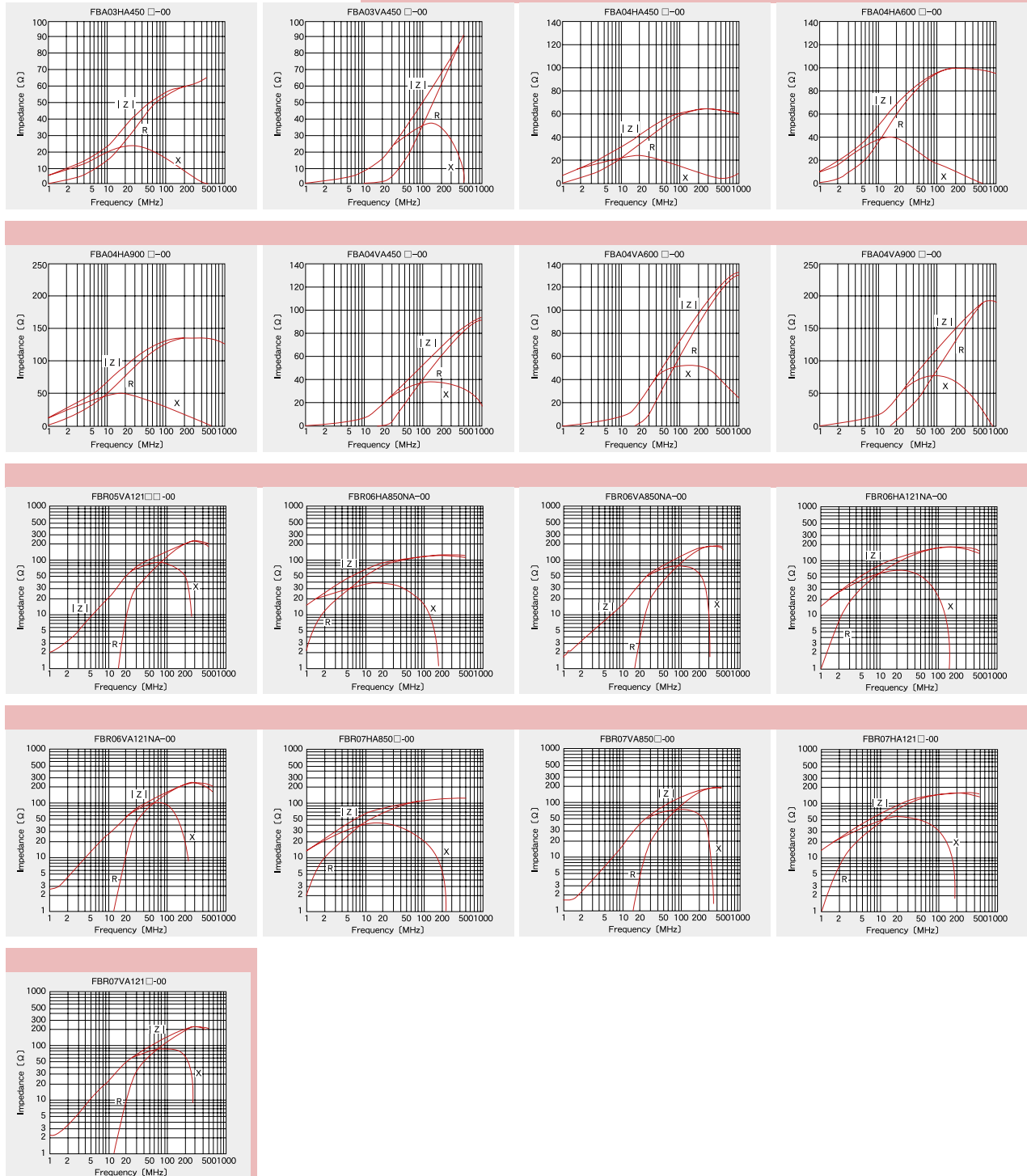

\* This catalog contains the typical specification only due to the limitation of space. When you consider the purchase of our products, please check our specification. For details of each product (characteristics graph, reliability information, precautions for use, and so on), see our Web site (<http://www.ty-top.com/>) or CD catalogs.

**PACKAGING**

① Minimum Quantity

● Axial lead (FBA)

Type	Lead Configuration	Standard quantity [pcs]	
		Bulk	Taped Ammo
FBA03	NA, KD, US	1000	—
	KE, KF, VS	500	—
	AB, BB	—	2000
	UB, VB	—	3000
FBA04	NA, KD, US	1000	—
	KE, KF, VS	500	—
	AB, BB	—	1000
	VB, UB	—	3000

● Radial lead (FBR)

Type	Lead Configuration	Standard quantity [pcs]	
		Bulk	Taped Ammo
FBR05	NA	1000	—
	SA	—	2000
FBR06	NA	1000	—
FBR07	NB	1000	—
	SB	—	2000

② Bulk dimensions

Axial lead (FBA)

● NA

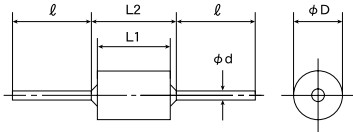

Type	Dimensions				
	φD	L1	L2	φd	ℓ
FBA03□450	2.5±0.2 (0.098±0.008)	4.5±0.3 (0.177±0.012)	6.5 max. (0.256 max.)	0.65±0.05 (0.026±0.002)	18 min. (0.709 min.)
FBA04□450	3.5±0.2 (0.138±0.008)	4.5±0.3 (0.177±0.012)	6.5 max. (0.256 max.)		
FBA04□600	3.5±0.2 (0.138±0.008)	6.0 <sup>+0.5</sup> <sub>-0</sub> (0.236 <sup>+0.020</sup> <sub>0</sub> )	8.5 max. (0.335 max.)		
FBA04□900	3.5±0.2 (0.138±0.008)	9.0±0.5 (0.354±0.020)	11.0 max. (0.433 max.)		

Unit : mm (inch)

● US

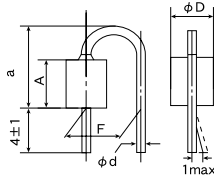

Type	Dimensions				
	φD	A	a	F	φd
FBA03□450	2.5±0.2 (0.098±0.008)	4.5±0.3 (0.177±0.012)	9.0 max. (0.354 max.)	5.0±1.0 (0.197±0.039)	0.65±0.05 (0.026±0.002)
FBA04□450	3.5±0.2 (0.138±0.008)	4.5±0.3 (0.177±0.012)	9.0 max. (0.354 max.)		

Unit : mm (inch)

● KD/KE/KF

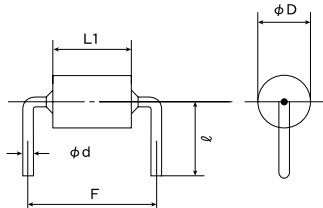

Type	Lead Symbol	Dimensions				
		φD	F	L1	φd	ℓ
FBA03□450	KD	2.5±0.2 (0.098±0.008)	10.0±1.0 (0.394±0.040)	4.5±0.3 (0.177±0.012)	0.65±0.05 (0.026±0.020)	7.0±2.0 (0.276±0.079)
FBA04□450		3.5±0.2 (0.138±0.008)	10.0±1.0 (0.394±0.040)	4.5±0.3 (0.177±0.012)		7.5±2.0 (0.295±0.079)
FBA04□600		3.5±0.2 (0.138±0.008)	10.0±1.0 (0.394±0.040)	6.0 <sup>+0.5</sup> <sub>-0</sub> (0.236 <sup>+0.020</sup> <sub>0</sub> )		7.5±2.0 (0.295±0.079)
FBA03□450	KE	2.5±0.2 (0.098±0.008)	12.5±1.0 (0.492±0.004)	4.5±0.3 (0.177±0.012)	0.65±0.05 (0.026±0.020)	7.0±2.0 (0.276±0.079)
FBA04□450		3.5±0.2 (0.138±0.008)	12.5±1.0 (0.492±0.004)	4.5±0.3 (0.177±0.012)		7.5±2.0 (0.295±0.079)
FBA04□600		3.5±0.2 (0.138±0.008)	12.5±1.0 (0.492±0.004)	6.0 <sup>+0.5</sup> <sub>-0</sub> (0.236 <sup>+0.020</sup> <sub>0</sub> )		7.5±2.0 (0.295±0.079)
FBA04□900		3.5±0.2 (0.138±0.008)	12.5±1.0 (0.492±0.004)	9.0±0.5 (0.354±0.020)		7.5±2.0 (0.295±0.079)
FBA03□450	KF	2.5±0.2 (0.098±0.008)	15.0±1.0 (0.591±0.004)	4.5±0.3 (0.177±0.012)	0.65±0.05 (0.026±0.020)	7.0±2.0 (0.276±0.079)
FBA04□450		3.5±0.2 (0.138±0.008)	15.0±1.0 (0.591±0.004)	4.5±0.3 (0.177±0.012)		7.5±2.0 (0.295±0.079)
FBA04□600		3.5±0.2 (0.138±0.008)	15.0±1.0 (0.591±0.004)	6.0 <sup>+0.5</sup> <sub>-0</sub> (0.236 <sup>+0.020</sup> <sub>0</sub> )		7.5±2.0 (0.295±0.079)
FBA04□900		3.5±0.2 (0.138±0.008)	15.0±1.0 (0.591±0.004)	9.0±0.53 (0.354±0.020)		7.5±2.0 (0.295±0.079)

Unit : mm (inch)

● VS

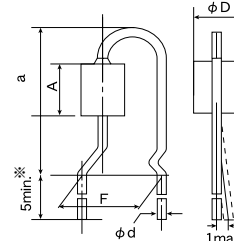

※5±1 for 900 type only

Type	Dimensions				
	φD	A	a	F	φd
FBA03□450	2.5±0.2 (0.098±0.008)	4.5±0.3 (0.177±0.012)	12.5 max. (0.492 max.)	5.0±1.0 (0.197±0.039)	0.65±0.05 (0.026±0.002)
FBA04□450	3.5±0.2 (0.138±0.008)	4.5±0.3 (0.177±0.012)	12.5 max. (0.492 max.)	5.0±1.0 (0.197±0.039)	0.65±0.05 (0.026±0.002)
FBA04□600	3.5±0.2 (0.138±0.008)	6.0 <sup>+0.5</sup> <sub>-0</sub> (0.236 <sup>+0.020</sup> <sub>0</sub> )	12.5 max. (0.492 max.)	5.0±1.0 (0.197±0.039)	0.65±0.05 (0.026±0.002)
FBA04□900	3.5±0.2 (0.138±0.008)	9.0±0.5 (0.354±0.020)	16.0 max. (0.630 max.)	5.0±1.0 (0.197±0.039)	0.65±0.05 (0.026±0.002)

Unit : mm (inch)

Radial lead (FBR)

● NA

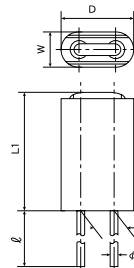

Type	Dimensions					
	D	L1	φd	ℓ	W	F
FBR05VA121	5.0 max. (0.197 max.)	9.0 max. (0.354 max.)	0.65±0.05 (0.026±0.002)	10.0 <sup>+3</sup> <sub>-5</sub> (0.394 <sup>+0.118</sup> <sub>-0.197</sub> )	2.5 max. (0.098 max.)	2.5±1.0 (0.098±0.039)
FBR06□850	6.0±0.5 (0.236±0.020)	7.0 max. (0.276 max.)	0.65±0.05 (0.026±0.002)	10.0 <sup>+3</sup> <sub>-5</sub> (0.394 <sup>+0.118</sup> <sub>-0.197</sub> )	3.0±0.5 (0.118±0.020)	2.5±1.0 (0.098±0.039)
FBR06□121	6.0±0.5 (0.236±0.020)	9.0 max. (0.354 max.)	0.65±0.05 (0.026±0.002)	10.0 <sup>+3</sup> <sub>-5</sub> (0.394 <sup>+0.118</sup> <sub>-0.197</sub> )	3.0±0.5 (0.118±0.020)	2.5±1.0 (0.098±0.039)

Unit : mm (inch)

\* This catalog contains the typical specification only due to the limitation of space. When you consider the purchase of our products, please check our specification. For details of each product (characteristics graph, reliability information, precautions for use, and so on), see our Web site (<http://www.ty-top.com/>) or CD catalogs.

● NB

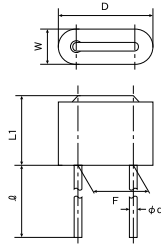

Type	Dimensions					
	D	L1	φd	ℓ	F	
FBR07□850	7.5±0.5 (0.295±0.020)	7.0 max. (0.276 max.)	0.6±0.05 (0.024±0.002)	5.0 <sup>+1</sup> <sub>-2</sub> (0.197 <sup>+0.039</sup> <sub>-0.079</sub> )	2.5 max. (0.098 max.)	5.0 <sup>+1</sup> <sub>-0.5</sub> (0.197 <sup>+0.039</sup> <sub>-0.020</sub> )
FBR07□121	7.5±0.5 (0.295±0.020)	9.0 max. (0.354 max.)	0.6±0.05 (0.024±0.002)	5.0 <sup>+1</sup> <sub>-2</sub> (0.197 <sup>+0.039</sup> <sub>-0.079</sub> )	2.5 max. (0.098 max.)	5.0 <sup>+1</sup> <sub>-0.5</sub> (0.197 <sup>+0.039</sup> <sub>-0.020</sub> )

Unit : mm (inch)

③ Taping Dimensions

● AB (a:26mm) (1.02inch lead space)

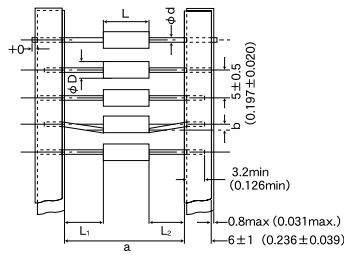

Type	Dimensions						Minimum insertion pitch
	φD	L	a	b	L1-L2	φd	
FBA03	2.5±0.2 (0.098±0.008)	4.5±0.3 (0.177±0.012)	26.0 <sup>+1.5</sup> <sub>-0</sub> (1.02 <sup>+0.059</sup> <sub>-0</sub> )	0.8 max (0.031 max)	1.0 max (0.039 max)	0.65±0.05 (0.026±0.002)	10.0 (0.394)
FBA04 □450		4.5±0.3 (0.177±0.012)					
FBA04 □600	3.5±0.2 (0.138±0.008)	6.0 <sup>+0.5</sup> <sub>-0</sub> (0.236 <sup>+0.020</sup> <sub>-0</sub> )	26.0 <sup>+1.5</sup> <sub>-0</sub> (1.02 <sup>+0.059</sup> <sub>-0</sub> )	0.8 max (0.031 max)	1.0 max (0.039 max)	0.65±0.05 (0.026±0.002)	10.0 (0.394)
FBA04 □900		9.0±0.5 (0.354±0.020)					

Unit : mm (inch)

● BB (a :52mm) (2.05inches lead space)

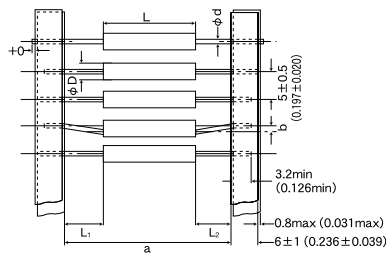

Type	Dimensions						Minimum insertion pitch
	φD	L	a	b	L1-L2	φd	
FBA03	2.5±0.2 (0.098±0.008)	4.5±0.3 (0.177±0.012)	52.0 <sup>+2</sup> <sub>-1</sub> (2.05 <sup>+0.079</sup> <sub>-0.039</sub> )	1.2 max (0.047 max)	1.0 max (0.039 max)	0.65±0.05 (0.026±0.002)	10.0 (0.394)
FBA04 □450		4.5±0.3 (0.177±0.012)					
FBA04 □600	3.5±0.2 (0.138±0.008)	6.0 <sup>+0.5</sup> <sub>-0</sub> (0.236 <sup>+0.020</sup> <sub>-0</sub> )	52.0 <sup>+2</sup> <sub>-1</sub> (2.05 <sup>+0.079</sup> <sub>-0.039</sub> )	1.2 max (0.047 max)	1.0 max (0.039 max)	0.65±0.05 (0.026±0.002)	10.0 (0.394)
FBA04 □900		9.0±0.5 (0.354±0.020)					

Unit : mm (inch)

● SA (F:2.5mm pitch) (0.098 inches)

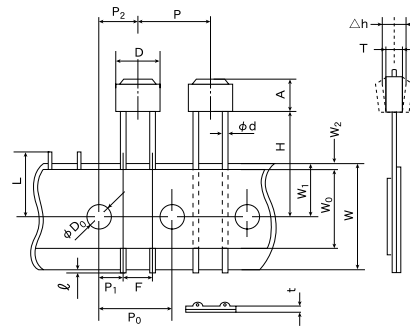

Type	Symbol	Dimensions	Symbol	Dimensions
FBR05	A	121: 9.0 max. (0.354 max.)	W	18.0 <sup>+1.0</sup> <sub>-0.5</sub> (0.709 <sup>+0.039</sup> <sub>-0.020</sub> )
	T	2.5 max. (0.098 max.)	W <sub>0</sub>	12.5 min. (0.492 min.)
	D	5.0 max. (0.197 max.)	W <sub>1</sub>	9.0 <sup>+0.75</sup> <sub>-0.5</sub> (0.354 <sup>+0.039</sup> <sub>-0.020</sub> )
	H	18.0 <sup>+2.0</sup> <sub>-0</sub> (0.709 <sup>+0.079</sup> <sub>-0</sub> )	W <sub>2</sub>	3.0 max. (0.118 max.)
	P	12.7±1.0 (0.500±0.039)	ℓ	1.0 max. (0.039 max.)
	P <sub>0</sub>	12.7±0.3 <sup>*1</sup> (0.500±0.039)	φD <sub>0</sub>	4.0±0.3 (0.157±0.012)
	P <sub>1</sub>	5.1±0.7 (0.201±0.028)	φd	0.65±0.05 (0.026±0.002)
	P <sub>2</sub>	6.35±1.3 (0.250±0.051)	L	11.0 max. (0.433 max.)
	F	2.5 <sup>+1.0</sup> <sub>-0.5</sub> (0.098 <sup>+0.039</sup> <sub>-0.020</sub> )	t	0.7±0.2 (0.028±0.008)
	△h	0.0±2.0 (0.0±0.079)		

Unit : mm (inch)

\*1 Accumulated error for 20 pitches is ±2mm.

\*2 Bonding tape must not protrude from the base tape.

\* This catalog contains the typical specification only due to the limitation of space. When you consider the purchase of our products, please check our specification. For details of each product (characteristics graph, reliability information, precautions for use, and so on), see our Web site (<http://www.ty-top.com/>) or CD catalogs.

PACKAGING

● SB/TB (F: 5mm pitch) (0.197 inches)

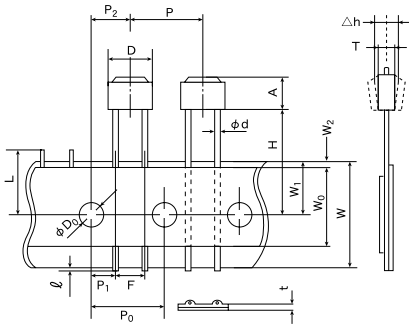

Type	Symbol	Dimensions	Symbol	Dimensions
FBR07	A	121: 9.0 max. (0.354 max.)	$\Delta h$	0.0±2.0 (0.0±0.079)
		850: 7.0 max. (0.276 max.)	W	18.0 <sup>+1.0</sup> <sub>-0.5</sub> (0.709 <sup>+0.039</sup> <sub>-0.020</sub> )
	T	2.5 max. (0.098 max.)	W <sub>0</sub>	12.5 min. (0.492 min.)
	D	7.5±0.5 (0.925±0.020)	W <sub>1</sub>	9.0 <sup>+0.75</sup> <sub>-0.5</sub> (0.354 <sup>+0.039</sup> <sub>-0.020</sub> )
	H	SB: 18.0 <sup>+2.0</sup> <sub>-0</sub> (0.709 <sup>+0.079</sup> <sub>-0</sub> )	W <sub>2</sub>	3.0 max. <sup>※2</sup> (0.118 max.)
		TB: 16.0±0.5 (0.630±0.020)	$\ell$	1.0 max. (0.039 max.)
	P	12.7±1.0 (0.500±0.039)	$\phi D_0$	4.0±0.3 (0.157±0.012)
	P <sub>0</sub>	12.7±0.3 <sup>※1</sup> (0.500±0.012)	$\phi d$	0.65±0.05 (0.02±0.002)
	P <sub>1</sub>	3.85±0.8 (0.152±0.028)	L	11.0 max. (0.433 max.)
	P <sub>2</sub>	6.35±1.3 (0.250±0.051)	t	0.7±0.2 (0.028±0.008)
F	5.0 <sup>+1.0</sup> <sub>-0.5</sub> (0.197 <sup>+0.039</sup> <sub>-0.020</sub> )			Unit : mm(inch)

※1 Accumulated error for 20 pitches is ±2mm.  
 ※2 Bonding tape must not protrude from the base tape.

● UB

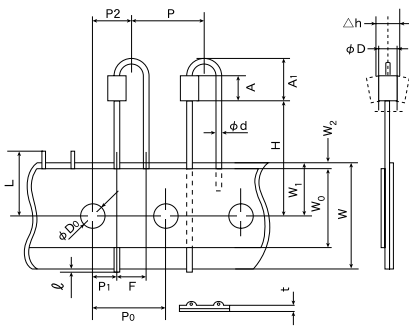

Type	Symbol	Dimensions	Symbol	Dimensions
FBA03□450 FBA04□450	A	4.5±0.3 (0.177±0.012)	$\Delta h$	0.0±2.0 (0.0±0.079)
	A <sub>1</sub>	9.0 max. (0.354 max.)	W	18.0 <sup>+1.0</sup> <sub>-0.5</sub> (0.709 <sup>+0.039</sup> <sub>-0.020</sub> )
	$\phi D$	03: 2.7 max. (0.106 max.)	W <sub>0</sub>	12.5 min. (0.492 min.)
		04: 3.7 max. (0.146 max.)	W <sub>1</sub>	9.0 <sup>+0.75</sup> <sub>-0.5</sub> (0.354 <sup>+0.039</sup> <sub>-0.020</sub> )
	H	20.0 <sup>+0.5</sup> <sub>-1.0</sub> (0.787 <sup>+0.020</sup> <sub>-0.039</sub> )	W <sub>2</sub>	3.0 max. <sup>※2</sup> (0.118 max.)
	P	12.7±1.0 (0.500±0.039)	$\ell$	1.0 max. (0.039 max.)
	P <sub>0</sub>	12.7±0.3 <sup>※1</sup> (0.500±0.012)	$\phi D_0$	4.0±0.3 (0.157±0.012)
	P <sub>1</sub>	3.85±0.8 (0.152±0.032)	$\phi d$	0.65±0.05 (0.026±0.002)
	P <sub>2</sub>	6.35±1.3 (0.250±0.051)	L	11.0 max. (0.433 max.)
	F	5.0±1.0 (0.197±0.039)	t	0.7±0.2 (0.028±0.008)

※1 Accumulated error for 20 pitches is ±2mm. Unit : mm (inch)  
 ※2 Bonding tape must not protrude from the base tape.

● VB

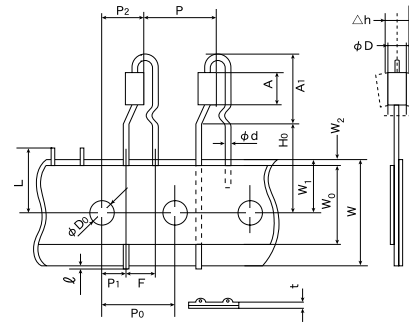

Type	Symbol	Dimensions	Symbol	Dimensions
FBA03□450 FBA04□450 FBA04□600 FBA04□900	A	450: 4.5±0.3 (0.177±0.012)	F	5.0±1.0 (0.197±0.039)
		600: 6.0 <sup>+0.5</sup> <sub>-0</sub> (0.236 <sup>+0.020</sup> <sub>-0</sub> )	$\Delta h$	0.0±2.0 (0.0±0.079)
		900: 9.0±0.5 (0.354±0.020)	W	18.0 <sup>+1.0</sup> <sub>-0.5</sub> (0.709 <sup>+0.039</sup> <sub>-0.020</sub> )
A <sub>1</sub>	450: 12.5 max. (0.492 max.)	W <sub>0</sub>	12.5 min. (0.492 min.)	
	600: 16.0 max. (0.630 max.)	W <sub>1</sub>	9.0 <sup>+0.75</sup> <sub>-0.5</sub> (0.354 <sup>+0.039</sup> <sub>-0.020</sub> )	
$\phi D$	3.7 max. (0.146 max.)	W <sub>2</sub>	3.0 max. <sup>※2</sup> (0.118 max.)	
H <sub>0</sub>	16.0±0.5 (0.650±0.020)	$\ell$	1.0 max. (0.039 max.)	
P	12.7±1.0 (0.500±0.039)	$\phi D_0$	4.0±0.3 (0.157±0.012)	
P <sub>0</sub>	12.7±0.3 <sup>※1</sup> (0.500±0.012)	$\phi d$	0.65±0.05 (0.026±0.002)	
P <sub>1</sub>	3.85±0.8 (0.152±0.032)	L	11.0 max. (0.433 max.)	
P <sub>2</sub>	6.35±1.3 (0.250±0.051)	t	0.7±0.2 (0.028±0.008)	

※1 Accumulated error for 20 pitches is ±2mm. Unit : mm (inch)  
 ※2 Bonding tape must not protrude from the base tape.

\* This catalog contains the typical specification only due to the limitation of space. When you consider the purchase of our products, please check our specification.  
 For details of each product (characteristics graph, reliability information, precautions for use, and so on), see our Web site (<http://www.ty-top.com/>) or CD catalogs.

## RELIABILITY DATA

### 1. Operating temperature Range

LA Type	
CAL45 Type	-25~+105°C
LHL□□□	
FBA/FBR	-25~+85°C
FL05□ Type	
FL06BT Type	-25~+105°C

#### [Test Method and Remarks]

LA·CA·FL : Including self-generated heat  
LHL□□□ : Including self-generated heat

### 2. Storage temperature Range

LA Type	
CAL45 Type	
LHL□□□	-40~+85°C
FBA/FBR	
FL05□ Type	
FL06BT Type	

### 3. Rated current

LA Type	
CAL45 Type	
LHL□□□	Within the specified tolerance
FBA/FBR	
FL05□ Type	
FL06BT Type	

#### [Test Method and Remarks]

LA, CA : The maximum DC value having inductance within 10% and temperature increase within 40°C (LA:20°C) by the application of DC bias.  
LHL□□□ : The maximum DC value having inductance decrease within 10% (LHLC08, LHLC10 : within 30%) and temperature increase within the following specified temperature by the application of DC bias.

Reference temperature : 25°C (LHL08, LHL10, LHL13)  
: 30°C (LHL16, LHLP□□)  
: 40°C (LHLC08, LHLC10)

FB : No disconnection or appearance abnormality by continuous current application for 30 min. Change after the application shall be within ±20% of the initial value.

This is not guaranteed for electrical characteristics during current application.

FL : The maximum DC value having temperature rise within specified value.

### 4. Impedance

LA Type	
CAL45 Type	
LHL□□□	
FBA/FBR	Within the specified tolerance
FL05□ Type	
FL06BT Type	Refer to individual specification

#### [Test Method and Remarks]

FB : Measuring equipment : Impedance analyzer (HP4191A) or its equivalent

Measuring frequency : Specified frequency

FL06BT : Measuring equipment : 4291A (HP) or its equivalent

Measuring frequency : Specified frequency

### 5. Inductance

LA Type	
CAL45 Type	Within the specified tolerance
LHL□□□	
FBA/FBR	
FL05□ Type	Within the specified tolerance
FL06BT Type	

#### [Test Method and Remarks]

LA, CA : Measuring equipment : LCR meter (HP4285A + HP42851A or its equivalent)  
Measuring frequency : Specified frequency

LHL□□□ : Measuring equipment : LCR meter (HP4285A+HP42851A or its equivalent)  
LCR meter (HP4263A) or its equivalent (at 1KHz)

Measuring frequency : Specified frequency  
FL05R□ : Measuring equipment : HP4262A or its equivalent  
Measuring frequency : 1kHz

### 6. Q

LA Type	Within the specified tolerance
CAL45 Type	
LHL□□□	
FBA/FBR	
FL05□ Type	
FL06BT Type	

#### [Test Method and Remarks]

LA : Measuring equipment : LCR meter (HP4285A + HP42851A or its equivalent)  
Measuring frequency : Specified frequency

LHL□□□ (except LHLP) : Measuring equipment : LCR meter (HP4285A+HP42851A or its equivalent)  
LCR meter (HP4263A) or its equivalent (at 1kHz)

Measuring frequency : Specified frequency

\* This catalog contains the typical specification only due to the limitation of space. When you consider the purchase of our products, please check our specification.  
For details of each product (characteristics graph, reliability information, precautions for use, and so on), see our Web site (<http://www.ty-top.com/>) or CD catalogs.



## RELIABILITY DATA

### 7. DC Resitance

LA Type	Within the specified tolerance
CAL45 Type	
LHL□□□	
FBA/FBR	
FL05□ Type	
FL06BT Type	

#### [Test Method and Remarks]

LA, CA : Measuring equipment : low ohmmeter (A&D AD5812 or its equivalent)  
 LHL□□□·FB·FL : Measuring equipment : DC ohmmeter

### 8. Self resonance frequency

LA Type	Within the specified tolerance
CAL45 Type	
LHL□□□	
FBA/FBR	
FL05□ Type	
FL06BT Type	

#### [Test Method and Remarks]

LA : Measuring equipment : Network analyzer (Anritsu MS620J or its equivalent)  
 LHL□□□ (except LHLP) : Measuring equipment : (HP4191A, 4192A) its equivalent

### 9. Temperature characteristic

LA Type	△L/L : Within ±5%
CAL45 Type	
LHL□□□	△L/L : Within ±7% (except LHLP16 : Within ±20%)
FBA/FBR	
FL05□ Type	
FL06BT Type	

#### [Test Method and Remarks]

LA : Change of maximum inductance deviation in step 1 to 5

Step	Temperature (°C)
1	20
2	-25 (Minimum operating temperature)
3	20 (Standard temperature)
4	+85 (Maximum operating temperature)
5	20

LHL□□□ : Change of maximum inductance deviation in step 1 to 5  
 Temperature at step 1 : 20°C  
 Temperature at step 2 : Minimum operating temperature  
 Temperature at step 3 : 20°C (Standard temperature)  
 Temperature at step 4 : Maximum operating temperature  
 Temperature at step 5 : 20°C

### 10. Tensile strength test

LA Type	No abnormality such as cut lead, or looseness.
CAL45 Type	
LHL□□□	
FBA/FBR	
FL05□ Type	
FL06BT Type	

#### [Test Method and Remarks]

LA : Apply the stated tensile force progressively in the direction to draw terminal.

force (N)	duration (s)
25	5

CA : Apply the stated tensile force progressively in the direction to draw terminal.

force (N)	duration (s)
10	10

LHL□□□ : Apply the stated tensile force progressively in the direction to draw terminal.

Nominal wire diameter tensile $\phi d$ (mm)	force (N)	duration (s)
$0.3 < \phi d \leq 0.5$	5	30±5
$0.5 < \phi d \leq 0.8$	10	
$0.8 < \phi d \leq 1.2$	25	

FBA/FBR : The body of a component shall be fixed and a tensile force of  $20 \pm 1$ N shall be applied to the lead wire in the axial direction of the component during  $10 \pm 1$  seconds.  
 FL05R□ : Fix the body of a component in the direction to draw terminal, and gradually apply the tensile force of 4.9N.

### 11. Over current

LA Type	No emission of smoke no firing.
CAL45 Type	
LHL□□□	There shall be no scorch or short of wire. LHLC08, LHLC10 : There shall be no firing.
FBA/FBR	
FL05□ Type	
FL06BT Type	

#### [Test Method and Remarks]

LHL□□□/LA·CAL45 Type : Measuring current : Rated current×2  
 Duration : 5 min.  
 Number of measuring : one time

\* This catalog contains the typical specification only due to the limitation of space. When you consider the purchase of our products, please check our specification.  
 For details of each product (characteristics graph, reliability information, precautions for use, and so on), see our Web site (<http://www.ty-top.com/>) or CD catalogs.

## RELIABILITY DATA

### 12. Terminal strength : bending

LA Type	No abnormality such as cut lead, or looseness.
CAL45 Type	
LHL□□□	
FBA/FBR	
FL05□ Type	
FL06BT Type	

#### [Test Method and Remarks]

LA, CA : Suspend a weight of specified mass at the end of the terminals and incline the body through the angle of 90 degrees and return it to the initial position. This operation is done over a period of 2-3 sec. Then second bend in the opposite direction shall be made.

Number of bends : Two times.

Nominal wire diameter tensile $\phi d$ (mm)	Bending force (N)	Mass reference weight (kg)
$0.3 < \phi d \leq 0.5$	2.5	0.25
$0.5 < \phi d \leq 0.8$	5	0.50

LH·FB : Suspend a weight of specified mass at the end of the terminals and incline the body through the angle of 90 degrees and return it to the initial position. This operation is done over a period of 2-3 sec. Then second bend in the opposite direction shall be made.

Number of bends : Two times.

Nominal wire diameter tensile $\phi d$ (mm)	Bending force (N)	Mass reference weight (kg)
$0.3 < \phi d \leq 0.5$	2.5	0.25
$0.5 < \phi d \leq 0.8$	5	0.5
$0.8 < \phi d \leq 1.2$	10	1.0

### 13. Insulation resistance : between the terminals and body

LA Type	100M $\Omega$ min.
CAL45 Type	
LHL□□□	
FBA/FBR	
FL05□ Type	
FL06BT Type	

#### [Test Method and Remarks]

LHL□□□ : Applied voltage : 500 VDC  
Duration : 60 sec.

### 14. Insulation resistance : between terminals and core

LA Type	1M $\Omega$ min. (Other than materail code MA)
CAL45 Type	
LHL□□□	
FBA/FBR	
FL05□ Type	
FL06BT Type	

#### [Test Method and Remarks]

FBA·FBR : Applied voltage : 100 VDC  
Duration : 60±5 sec.

### 15. Withstanding : between the terminals and body

LA Type	No abnormality such as insulation damage
CAL45 Type	
LHL□□□	
FBA/FBR	
FL05□ Type	
FL06BT Type	

#### [Test Method and Remarks]

LHL□□□ : According to JIS C5102. 7. 1. 3 (C)  
Metal global method  
Applied voltage : 500 VDC  
Duration : 60 sec.

### 16. DC bias characteristic

LA Type	$\Delta L/L$ : Within -10%
CAL45 Type	
LHL□□□	
FBA/FBR	
FL05□ Type	
FL06BT Type	

#### [Test Method and Remarks]

LA, CA : Measure inductance with application of rated current using LCR meter to compare it with the initial value.

### 17. Body strength

LA Type	No abnormality as damage.
CAL45 Type	
LHL□□□	
FBA/FBR	No abnormality such as cracks on body.
FL05□ Type	
FL06BT Type	

#### [Test Method and Remarks]

LA : Applied force : 30N  
Duration : 10 sec.  
Speed : Shall attain to specified force in 2 sec.

CAL45 : Applied force : 50N  
Duration : 10 sec.  
Speed : Shall attain to specified force in 2 sec.

FBA : Applied force : 50±3N  
Duration : 30±1 sec.

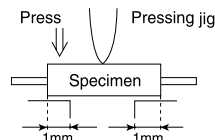

\* This catalog contains the typical specification only due to the limitation of space. When you consider the purchase of our products, please check our specification.  
For details of each product (characteristics graph, reliability information, precautions for use, and so on), see our Web site (<http://www.ty-top.com/>) or CD catalogs.

## RELIABILITY DATA

18. Resistance to vibration	
LA Type	$\Delta$ L/L : Within $\pm 5\%$ Q : 30min
CAL45 Type	$\Delta$ L/L : Within $\pm 5\%$
LHL□□□	Appearance : No abnormality $\Delta$ L/L : Within $\pm 5\%$ Q change : Within $\pm 30\%$ (LHLP : only $\Delta$ L/L)
FBA/FBR	Appearance : No abnormality Impedance change : Within $\pm 20\%$
FL05□ Type	
FL06BT Type	

### [Test Method and Remarks]

LA, CA : Directions : 2 hrs each in X, Y and Z directions total : 6hrs.  
 Frequency range : 10 to 55 to 10Hz (1min.)  
 Amplitude : 1.5mm  
 Mounting method : Soldering onto printed board.  
 Recovery : At least 1hr of recovery under the standard condition after the test, followed by the measurement within 2hrs.

LHL□□□·FB : Directions : 2 hrs each in X, Y and Z directions total : 6hrs.  
 Frequency range : 10 to 55 to 10Hz (1min.)  
 Amplitude : 1.5mm (But don't exceed acceleration 196m/s<sup>2</sup> (two power))  
 Mounting method : Soldering onto printed board.

19. Resistance to shock	
LA Type	No significant abnormality in appearance
CAL45 Type	
LHL□□□	
FBA/FBR	
FL05□ Type	
FL06BT Type	

### [Test Method and Remarks]

LA, CA : Drop test  
 Impact material : concrete or vinyl tile  
 Height : 1m  
 Total number of drops : 10 times

20. Solderability	
LA Type	At least 75% of terminal electrode is covered by new solder.
CAL45 Type	
LHL□□□	At least 75% of terminal electrode is covered by new solder.
FBA/FBR	At least 90% of terminal electrode is covered by new solder.
FL05□ Type	
FL06BT Type	At least 75% of terminal electrode is covered by new solder.

### [Test Method and Remarks]

LA, CA : Solder temperature : 230 $\pm$ 5 $^{\circ}$ C  
 Duration : 2 $\pm$ 0.5 sec.

LHL□□□ : Solder temperature : 235 $\pm$ 5 $^{\circ}$ C  
 Duration : 2 $\pm$ 0.5 sec.  
 Immersion depth : Up to 1.5mm from bottom of case.

FB : Solder temperature : 230 $\pm$ 5 $^{\circ}$ C  
 Duration : 3 $\pm$ 1 sec.  
 Immersion depth : Up to 1.5mm from terminal root.

FL05R□ : Solder temperature : 230 $\pm$ 5 $^{\circ}$ C  
 Duration : 2 $\pm$ 0.5 sec.  
 Immersion depth : Up to 2 to 2.5mm from terminal root.

FL06BT : Solder temperature : 230 $\pm$ 5 $^{\circ}$ C  
 Duration : 3 $\pm$ 1 sec.  
 Immersion depth : Up to 0.5 to 1.0mm from terminal root.

21. Resistance to soldering heat	
LA Type	No significant abnormality in appearance
CAL45 Type	$\Delta$ L/L : Within $\pm 5\%$
LHL□□□	No significant abnormality in appearance Inductance change : Within $\pm 5\%$ Q change : Within $\pm 30\%$ (LHLP : only $\Delta$ L/L)
FBA/FBR	No significant abnormality in appearance Impedance change : Within $\pm 20\%$
FL05□ Type	Refer to individual specification
FL06BT Type	No significant abnormality in appearance Impedance change : Within $\pm 20\%$

### [Test Method and Remarks]

LA, CA : Solder temperature : (CA) 270 $\pm$ 5 $^{\circ}$ C, (LA) 260 $\pm$ 5 $^{\circ}$ C  
 Duration : 5 $\pm$ 0.5 sec. One time  
 Immersed conditions : Inserted into substrate with t=1.6mm  
 Recovery : At least 1hr of recovery under the standard condition after the test, followed by the measurement within 2hrs.

LHL□□□ : Solder bath method : Solder temperature : 260 $\pm$ 5 $^{\circ}$ C  
 Duration : 10 $\pm$ 1 sec.  
 Up to 1.5mm from the bottom of case.

Manual soldering : Solder temperature : 350 $\pm$ 10 $^{\circ}$ C (At the tip of soldering iron)  
 Duration : 5 $\pm$ 1 sec.  
 Up to 1.5mm from the bottom of case.

Caution : No excessive pressing shall be applied to terminals.  
 Recovery : 4 to 24hrs of recovery under the standard condition after the test.

FB : Solder bath method : Condition 1 : Solder temperature : 260 $\pm$ 5 $^{\circ}$ C  
 Duration : 10 $\pm$ 1 sec.  
 Immersion depth : Up to 1.5mm from the terminal root.

Condition 2 : Solder temperature : 350 $\pm$ 5 $^{\circ}$ C  
 Duration : 3 $\pm$ 1 sec.  
 Immersion depth : Up to 1.5mm from the terminal root.

Recovery : 3hrs of recovery under the standard condition after the test.

FL : Solder condition : 260 $\pm$ 5 $^{\circ}$ C 10 $\pm$ 1 sec.  
 Immersion depth : Up to 0.5 to 1.0mm from the terminal root.  
 Recovery : 3hrs of recovery under the standard condition after the test.

\* This catalog contains the typical specification only due to the limitation of space. When you consider the purchase of our products, please check our specification.  
 For details of each product (characteristics graph, reliability information, precautions for use, and so on), see our Web site (<http://www.ty-top.com/>) or CD catalogs.

## RELIABILITY DATA

### 22. Resisistance to solvent

LA Type	Please avoid the ultrasonic cleaning of this product.	
CAL45 Type		
LHL□□□		
FBA/FBR		No significant abnormality in appearance      Impedance change : Within ±20%
FL05□ Type		
FL06BT Type		

#### [Test Method and Remarks]

FB : Solvent temperature : 20~25°C  
 Duration : 30±5 sec.  
 Solvent type : Acetone, trichloroethylene  
 Recovery : 3hrs of recovery under the standard condition after the test.

### 23. Thermal shock

LA Type	△L/L : Within ±10%    Q : 30min		
CAL45 Type	△L/L : Within ±10%		
LHL□□□	Appearance : No abnormality	Inductance change : Within ±10%	Q change : Within ±30% (LHLP : only △L/L)
FBA/FBR	Appearance : No abnormality	Impedance change : Within ±20%	
FL05□ Type	Refer to individual specification		
FL06BT Type	Appearance : No abnormality	Impedance change : Within ±20%	

#### [Test Method and Remarks]

LA, CA : Conditions for 1 cycle

Step	Temperature (°C)	Duration (min.)
1	-25 <sup>+0</sup> <sub>-3</sub>	30±3
2	Room temperature	Within 3
3	+85 <sup>+2</sup> <sub>-0</sub>	30±3
4	Room temperature	Within 3

Number of cycles : 5 cycles  
 Recovery : At least 1hr of recovery under the standard condition after the removal from test chamber, followed by the measurement within 2hrs.

LHL□□□·FB : According to JIS C0025

Conditions for 1 cycle

Step	Temperature (°C)	Duration (min.)
1	Minimum operating temperature <sup>+0</sup> <sub>-3</sub>	30±3
2	Room temperature	Within 3
3	Minimum operating temperature <sup>+2</sup> <sub>-0</sub>	30±3
4	Room temperature	Within 3

Number of cycles : 10 cycles (LHL□□□)  
 : 5 cycles (FBA, FBR)  
 Recovery : 4 to 24hrs of recovery under the standard condition after the removal from the test chamber. (LHL□□□)  
 : 3hrs of recovery under the standard condition after the removal from the test chamber. (FBA, FBR)

FL : According to JIS C0025

Conditions for 1 cycle

Step	Temperature (°C)	Duration (min.)
1	-25 <sup>+0</sup> <sub>-3</sub>	30±3
2	Room temperature	Within 3
3	+85 <sup>+2</sup> <sub>-0</sub>	30±3
4	Room temperature	Within 3

Number of cycles : 10 cycles  
 Recovery : 1 to 2hrs of recovery under the standard condition after the removal from the test chamber.

### 24. Damp heat

LA Type	△L/L : Within ±10%    Q : 30min
CAL45 Type	△L/L : Within ±10%
LHL□□□	
FBA/FBR	Appearance : No abnormality      Impedance change : Within ±20%
FL05□ Type	
FL06BT Type	

#### [Test Method and Remarks]

LA, CA : Temperature : 40±2°C  
 Humidity : 90~95%RH  
 Duration : 1000 hrs  
 Recovery : At least 1hr of recovery under the standard removal from test chamber, followed by the measurement within 2hrs.

FB : Temperature : 60±2°C

Humidity : 90~95%RH  
 Duration : 1000 hrs  
 Recovery : 1 to 2hrs of recovery under the standard condition after the removal from the test chamber.

\* This catalog contains the typical specification only due to the limitation of space. When you consider the purchase of our products, please check our specification.  
 For details of each product (characteristics graph, reliability information, precautions for use, and so on), see our Web site (<http://www.ty-top.com/>) or CD catalogs.

## RELIABILITY DATA

25. Loading under damp heat	
LA Type	△L/L : Within ±10% Q : 30min
CAL45 Type	△L/L : Within ±10%
LHL□□□	Appearance : No abnormality Inductance change : Within ±10% Q change : Within ±30% (LHLP : only △L/L)
FBA/FBR	
FL05□ Type	Refer to individual specification
FL06BT Type	Appearance : No abnormality Impedance change : Within ±20%
[Test Method and Remarks]	
LA, CA	Temperature : 40±2°C Humidity : 90~95%RH Duration : 1000 hrs Applied current : Rated current Recovery : At least 1hr of recovery under the standard removal from test chamber, followed by the measurement within 2hrs.
LHL□□□	Temperature : 40±2°C Humidity : 90~95%RH Duration : 1000±24 hrs Applied current : Rated current Recovery : 1 to 2hrs of recovery under the standard condition after the removal from the test chamber.
FL	Temperature : 60±3°C Humidity : 90~95%RH Duration : 500 (+12, -0) hrs Applied current : Rated current Recovery : 1 to 2hrs of recovery under the standard condition after the removal from the test chamber.
26. Loading at high temperature	
LA Type	△L/L : Within ±10% Q : 30min
CAL45 Type	△L/L : Within ±10%
LHL□□□	
FBA/FBR	
FL05□ Type	
FL06BT Type	
[Test Method and Remarks]	
LA, CA	Temperature : 85±2°C Duration : 1000 hrs Applied current : Rated current Recovery : At least 1hr of recovery under the standard removal from test chamber, followed by the measurement within 2hrs.
27. Low temperature life test	
LA Type	△L/L : Within ±10% Q : 30min
CAL45 Type	△L/L : Within ±10%
LHL□□□	Appearance : No abnormality Inductance change : Within ±10% Q change : Within ±30% (LHLP : only △L/L)
FBA/FBR	
FL05□ Type	Refer to individual specification
FL06BT Type	Appearance : No abnormality Impedance change : Within ±20%
[Test Method and Remarks]	
LA, CA	Temperature : -25±2°C Duration : 1000 hrs Recovery : At least 1hr of recovery under the standard removal from test chamber, followed by the measurement within 2hrs.
LHL□□□	Temperature : -40±3°C Duration : 1000±24 hrs Recovery : 1 to 2hrs of recovery under the standard condition after the removal from the test chamber.
FL	Temperature : -40±3°C Duration : 500 (+12, -0) hrs Recovery : 1 to 2hrs of recovery under the standard condition after the removal from the test chamber.
28. High temperature life test	
LA Type	
CAL45 Type	
LHL□□□	Appearance : No abnormality Inductance change : Within ±10% Q change : Within ±30% (LHLP : only △L/L)
FBA/FBR	
FL05□ Type	Refer to individual specification
FL06BT Type	Appearance : No abnormality Impedance change : Within ±20%
[Test Method and Remarks]	
LHL□□□	Temperature : 105±3°C Duration : 1000±24 hrs Recovery : 1 to 2hrs of recovery under the standard condition after the removal from the test chamber.
FL	Temperature : 85±3°C Duration : 500 (+12, -0) hrs Recovery : 1 to 2hrs of recovery under the standard condition after the removal from the test chamber.

\* This catalog contains the typical specification only due to the limitation of space. When you consider the purchase of our products, please check our specification.  
For details of each product (characteristics graph, reliability information, precautions for use, and so on), see our Web site (<http://www.ty-top.com/>) or CD catalogs.

## PRECAUTIONS

CAL Type, LH Type, FB Type, FL Type, LA Type

1. Circuit Design	
Precautions	<ul style="list-style-type: none"> <li>◆ Operating environment               <ol style="list-style-type: none"> <li>1. The products described in this specification are intended for use in general electronic equipment (office supply equipment, telecommunications systems, measuring equipment, and household equipment). They are not intended for use in mission-critical equipment or systems requiring special quality and high reliability (traffic systems, safety equipment, aerospace systems, nuclear control systems and medical equipment including life-support systems,) where product failure might result in loss of life, injury or damage. For such uses, contact TAIYO YUDEN Sales Department in advance.</li> </ol> </li> </ul>
2. PCB Design	
Precautions	<ul style="list-style-type: none"> <li>◆ Design               <ol style="list-style-type: none"> <li>1. Please design insertion pitches as matching to that of leads of the component on PCBs.</li> </ol> </li> </ul>
Technical considerations	<ul style="list-style-type: none"> <li>◆ Design               <ol style="list-style-type: none"> <li>1. When Inductors are mounted onto a PC board, hole dimensions on the board should match the lead pitch of the component, if not, it will cause breakage of the terminals or cracking of terminal roots covered with resin as excess stress travels through the terminal legs.</li> </ol> </li> </ul>
3. Considerations for automatic placement	
Precautions	<ul style="list-style-type: none"> <li>◆ Adjustment of mounting machine               <ol style="list-style-type: none"> <li>1. Excessive impact load should not be imposed on the products when mounting onto the PC boards.</li> <li>2. Mounting and soldering conditions should be checked beforehand.</li> </ol> </li> </ul>
Technical considerations	<ul style="list-style-type: none"> <li>◆ Adjustment of mounting machine               <ol style="list-style-type: none"> <li>1. When installing products, care should be taken not to apply distortion stress as it may deform the products.</li> </ol> </li> </ul>
4. Soldering	
Precautions	<ul style="list-style-type: none"> <li>◆ Wave soldering               <ol style="list-style-type: none"> <li>1. Please refer to the specifications in the catalog for a wave soldering.</li> <li>2. Do not immerse the entire inductor in the flux during the soldering operation.</li> </ol> </li> <li>◆ Lead free soldering               <ol style="list-style-type: none"> <li>1. When using products with lead free soldering, we request to use them after confirming adhesion, temperature of resistance to soldering heat, soldering etc sufficiently.</li> </ol> </li> </ul>
	<p>Recommended conditions for using a soldering iron:</p> <ul style="list-style-type: none"> <li>• Put the soldering iron on the land-pattern.</li> <li>• Soldering iron's temperature - Below 350°C</li> <li>• Duration - 3 seconds or less</li> <li>• The soldering iron should not directly touch the inductor.</li> </ul>
	<ul style="list-style-type: none"> <li>◆ Reflow soldering               <ol style="list-style-type: none"> <li>1. As for reflow soldering, please contact our sales staff.</li> </ol> </li> </ul>
Technical considerations	<ul style="list-style-type: none"> <li>◆ Lead free soldering               <ol style="list-style-type: none"> <li>1. If products are used beyond the range of the recommended conditions, heat stresses may deform the products, and consequently degrade the reliability of the products.</li> </ol> </li> </ul>
5. Cleaning	
Precautions	<ul style="list-style-type: none"> <li>◆ Cleaning conditions               <ol style="list-style-type: none"> <li>1. CAL type, LH type, LA Type Please do not do cleaning by a supersonic wave.</li> </ol> </li> </ul>
Technical considerations	<ul style="list-style-type: none"> <li>◆ Cleaning conditions               <ol style="list-style-type: none"> <li>1. CAL type, LH type, LA Type If washing by supersonic waves, supersonic waves may deform products.</li> </ol> </li> </ul>
6. Handling	
Precautions	<ul style="list-style-type: none"> <li>◆ Handling               <ol style="list-style-type: none"> <li>1. Keep the inductors away from all magnets and magnetic objects.</li> </ol> </li> <li>◆ Mechanical considerations               <ol style="list-style-type: none"> <li>1. Please do not give the inductors any excessive mechanical shocks.</li> <li>2. LH type If inductors are dropped onto the floor or a hard surface they should not be used.</li> </ol> </li> <li>◆ Packing               <ol style="list-style-type: none"> <li>1. Please do not give the inductors any excessive mechanical shocks. In loading, please pay attention to handling indication mentioned in a packing box (a loading direction / number of maximum loading / fragile item).</li> </ol> </li> </ul>
	Technical considerations
7. Storage conditions	
Precautions	<ul style="list-style-type: none"> <li>◆ Storage               <ol style="list-style-type: none"> <li>1. To maintain the solderability of terminal electrodes and to keep the packing material in good condition, temperature and humidity in the storage area should be controlled.</li> </ol> </li> </ul> <p>Recommended conditions</p> <ul style="list-style-type: none"> <li>• Ambient temperature 0~40°C</li> <li>• Humidity Below 70% RH</li> </ul> <p>The ambient temperature must be kept below 30°C. Even under ideal storage conditions, solderability of products electrodes may decrease as time passes. For this reason, inductors should be used within one year from the time of delivery. In case of storage over 6 months, solderability shall be checked before actual usage.</p>
Technical considerations	<ul style="list-style-type: none"> <li>◆ Storage               <ol style="list-style-type: none"> <li>1. Under a high temperature and humidity environment, problems such as reduced solderability caused by oxidation of terminal electrodes and deterioration of taping/packaging materials may take place.</li> </ol> </li> </ul>

\* This catalog contains the typical specification only due to the limitation of space. When you consider the purchase of our products, please check our specification. For details of each product (characteristics graph, reliability information, precautions for use, and so on), see our Web site (<http://www.ty-top.com/>) or CD catalogs.