

**Small Signal Diode**

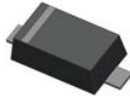

**Features**

- ✧Wide zener voltage range selection : 2.4V to 56V
- ✧V<sub>Z</sub> Tolerance Selection of ±5%
- ✧Moisture sensitivity level 1
- ✧Matte Tin(Sn) lead finish
- ✧Pb free version and RoHS compliant
- ✧Green compound (Halogen free) with suffix "G" on packing code and prefix "G" on date code

**Mechanical Data**

- ✧Case : Flat lead SOD-123 small outline plastic package
- ✧Terminal: Matte tin plated, lead free., solderable per MIL-STD-202, Method 208 guaranteed
- ✧High temperature soldering guaranteed: 260°C/10s
- ✧Polarity : Indicated by cathode band
- ✧Weight : 8.85±0.5 mg

**Ordering Information**

Package	Part No.	Packing
SOD-123F	MMSZ52xxB RH	3Kpcs / 7" Reel
SOD-123F	MMSZ52xxB RHG	3Kpcs / 7" Reel

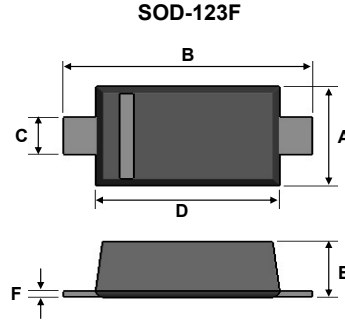

Dimensions	Unit (mm)		Unit (inch)	
	Min	Max	Min	Max
A	1.5	1.7	0.059	0.067
B	3.3	3.9	0.130	0.154
C	0.5	0.7	0.020	0.028
D	2.5	2.7	0.098	0.106
E	0.8	1.15	0.031	0.045
F	0.05	0.2	0.002	0.008

**Pin Configuration**



**Suggested PAD Layout**

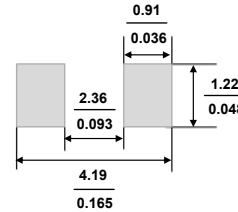

**Maximum Ratings and Electrical Characteristics**

Rating at 25°C ambient temperature unless otherwise specified.

**Maximum Ratings**

Type Number	Symbol	Value	Units
Power Dissipation	P <sub>D</sub>	500	mW
Forward Voltage	V <sub>F</sub> (I <sub>F</sub> =10mA)	0.9	V
Thermal Resistance (Junction to Ambient)	RθJA	330	°C/W
Junction and Storage Temperature Range	T <sub>J</sub> , T <sub>STG</sub>	-65 to + 150	°C

Notes:1. Valid provided that electrodes are kept at ambient temperature

**Zener I vs. V Characteristics**

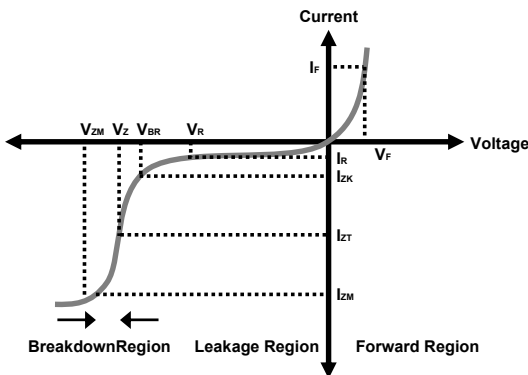

- V<sub>BR</sub> : Voltage at I<sub>ZK</sub>
- I<sub>ZK</sub> : Test current for voltage V<sub>BR</sub>
- Z<sub>ZK</sub> : Dynamic impedance at I<sub>ZK</sub>
- I<sub>ZT</sub> : Test current for voltage V<sub>Z</sub>
- V<sub>Z</sub> : Voltage at current I<sub>ZT</sub>
- Z<sub>ZT</sub> : Dynamic impedance at I<sub>ZT</sub>
- I<sub>ZM</sub> : Maximum steady state current
- V<sub>ZM</sub> : Voltage at I<sub>ZM</sub>

**Small Signal Diode**

**Electrical Characteristics**

Ta = 25°C unless otherwise noted

V<sub>F</sub> Forward Voltage = 0.9V Maximum @ I<sub>F</sub> = 10 mA for all part numbers

Part Number	Marking Code	V <sub>Z</sub> @ I <sub>ZT</sub> (Volt)			I <sub>ZT</sub> (mA)	Z <sub>ZT</sub> @ I <sub>ZT</sub> (Ω) Max	I <sub>ZK</sub> (mA)	Z <sub>ZK</sub> @ I <sub>ZK</sub> (Ω) Max	I <sub>R</sub> @ V <sub>R</sub> (μA) Max	V <sub>R</sub> (V)
		Min	Nom	Max						
MMSZ5221B	Z2V4	2.28	2.4	2.52	20	30	0.25	1200	100	1
MMSZ5222B	Z2V5	2.38	2.5	2.63	20	30	0.25	1250	100	1
MMSZ5223B	Z2V7	2.57	2.7	2.84	20	30	0.25	1300	75	1
MMSZ5224B	Z2V8	2.66	2.8	2.94	20	30	0.25	1400	75	1
MMSZ5225B	Z3V0	2.85	3.0	3.15	20	29	0.25	1600	50	1
MMSZ5226B	Z3V3	3.14	3.3	3.47	20	28	0.25	1600	25	1
MMSZ5227B	Z3V6	3.42	3.6	3.78	20	24	0.25	1700	15	1
MMSZ5228B	Z3V9	3.71	3.9	4.10	20	23	0.25	1900	10	1
MMSZ5229B	Z4V3	4.09	4.3	4.52	20	22	0.25	2000	5	1
MMSZ5230B	Z4V7	4.47	4.7	4.94	20	19	0.25	1900	5	2
MMSZ5231B	Z5V1	4.85	5.1	5.36	20	17	0.25	1600	5	2
MMSZ5232B	Z5V6	5.32	5.6	5.88	20	11	0.25	1600	5	3
MMSZ5233B	Z6V0	5.70	6.0	6.30	20	7	0.25	1600	5	3.5
MMSZ5234B	Z6V2	5.89	6.2	6.51	20	7	0.25	1000	5	4
MMSZ5235B	Z6V8	6.46	6.8	7.14	20	5	0.25	750	3	5
MMSZ5236B	Z7V5	7.13	7.5	7.88	20	6	0.25	500	3	6
MMSZ5237B	Z8V2	7.79	8.2	8.61	20	8	0.25	500	3	6.5
MMSZ5238B	Z8V7	8.27	8.7	9.14	20	8	0.25	600	3	6.5
MMSZ5239B	Z9V1	8.65	9.1	9.56	20	10	0.25	600	3	7
MMSZ5240B	Z10V	9.50	10	10.50	20	17	0.25	600	3	8
MMSZ5241B	Z11V	10.45	11	11.55	20	22	0.25	600	2	8.4
MMSZ5242B	Z12V	11.40	12	12.60	20	30	0.25	600	1	9.1
MMSZ5243B	Z13V	12.35	13	13.65	9.5	13	0.25	600	0.5	9.9
MMSZ5244B	Z14V	13.30	14	14.70	9.0	15	0.25	600	0.1	10
MMSZ5245B	Z15V	14.25	15	15.75	8.5	16	0.25	600	0.1	11
MMSZ5246B	Z16V	15.20	16	16.80	7.8	17	0.25	600	0.1	12
MMSZ5247B	Z17V	16.15	17	17.85	7.4	19	0.25	600	0.1	13
MMSZ5248B	Z18V	17.10	18	18.90	7.0	21	0.25	600	0.1	14
MMSZ5249B	Z19V	18.05	19	19.95	6.6	23	0.25	600	0.1	14
MMSZ5250B	Z20V	19.00	20	21.00	6.2	25	0.25	600	0.1	15
MMSZ5251B	Z22V	20.90	22	23.10	5.6	29	0.25	600	0.1	17
MMSZ5252B	Z24V	22.80	24	25.20	5.2	33	0.25	600	0.1	18
MMSZ5253B	Z25V	23.75	25	26.25	5.0	35	0.25	600	0.1	19
MMSZ5254B	Z27V	25.65	27	28.35	4.6	41	0.25	600	0.1	21
MMSZ5255B	Z28V	26.60	28	29.40	4.5	44	0.25	600	0.1	21
MMSZ5256B	Z30V	28.50	30	31.50	4.2	49	0.25	600	0.1	23
MMSZ5257B	Z33V	31.35	33	34.65	3.8	58	0.25	700	0.1	25
MMSZ5258B	Z36V	34.20	36	37.80	3.4	70	0.25	700	0.1	27
MMSZ5259B	Z39V	37.05	39	40.95	3.2	80	0.25	800	0.1	30
MMSZ5260B	Z43V	40.85	43	45.15	3.0	93	0.25	900	0.1	33
MMSZ5261B	Z47V	44.65	47	49.35	2.7	105	0.25	1000	0.1	36
MMSZ5262B	Z51V	48.45	51	53.55	2.5	125	0.25	1100	0.1	39
MMSZ5263B	Z56V	53.20	56	58.80	2.2	150	0.25	1300	0.1	43

**Notes:**

1. The Zener Voltage (V<sub>Z</sub>) is tested under pulse condition of 1ms.
2. The device numbers listed have a standard tolerance on the nominal zener voltage of **±5%**.
3. For detailed information on price, availability and delivery of nominal zener voltages between the voltages shown and tighter voltage tolerances, contact your nearest **Taiwan semiconductor** representative.
4. The zener impedance is derived from the 60-cycle ac voltage, which results when an ac current having an rms value equal to 10% of the DC zener current (I<sub>ZT</sub> or I<sub>ZK</sub>) is superimposed to I<sub>ZT</sub> or I<sub>ZK</sub>.

**Rating and Characteristic Curves**

**FIG 1 Typical Forward Voltage**

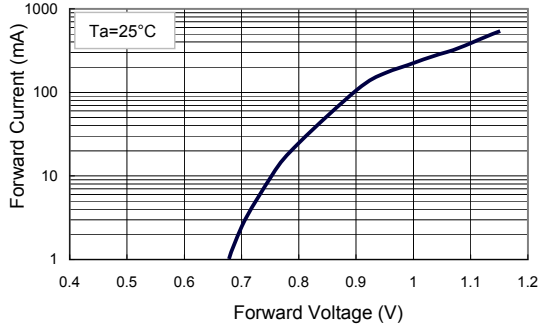

**FIG 2 Zener Breakdown Characteristics**

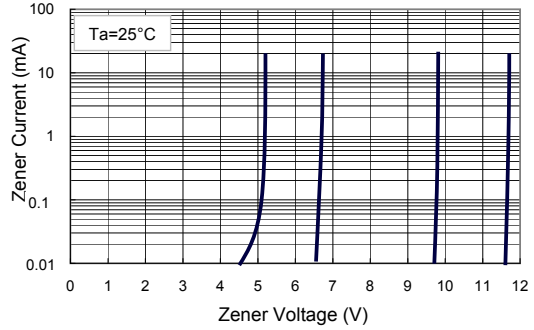

**FIG 3 Zener Breakdown Characteristics**

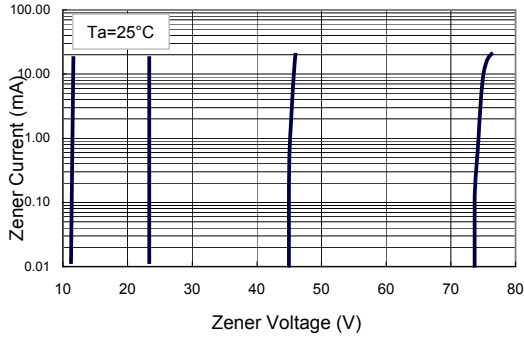

**FIG 4 Power Dissipation vs. Ambient Temp.**

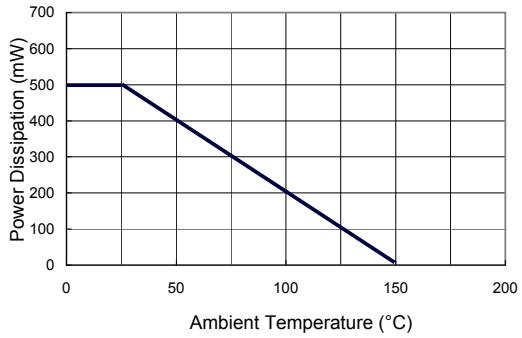

**FIG 5 Typical Capacitance**

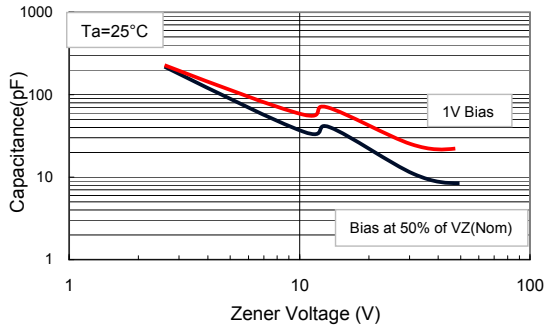

**FIG 6 Effect of Zener Voltage on Impedance**

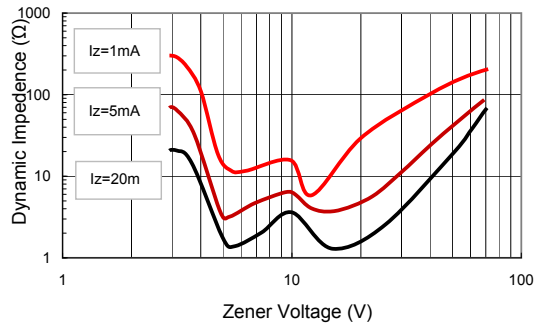

Small Signal Diode

**MMSZ5221B~MMSZ5263B**  
**500mW, 5% Tolerance SMD Zener Diode**

Tape & Reel specification

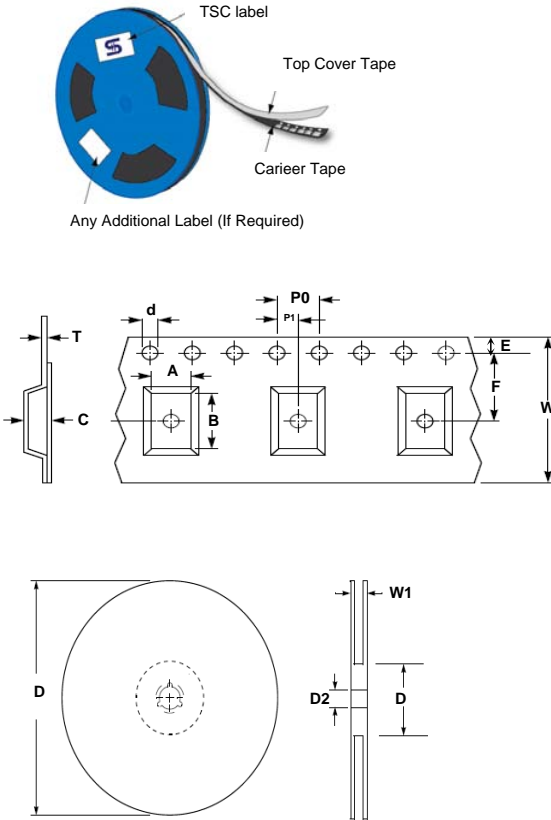

Item	Symbol	Dimension(mm)
Carrier width	A	3.15 ±0.10
Carrier length	B	3.94 ±0.05
Carrier depth	C	1.35 ±0.10
Sprocket hole	d	1.75 ±0.10
Reel outside diameter	D	178 ±1
Reel inner diameter	D1	54.4 ±0.40
Feed hole width	D2	13.0 ±0.20
Sprocket hole position	E	1.75 ±0.10
Punch hole position	F	3.50 ±0.05
Sprocket hole pitch	P0	4.00 ±0.10
Embossment center	P1	2.00 ±0.05
Overall tape thickness	T	0.22 ±0.05
Tape width	W	8.10 ±0.20
Reel width	W1	12.3 ±0.20

