

CAT5128

32-Tap Digital Up/Down Control Potentiometer

Description

The CAT5128 is a single digitally programmable potentiometer (DPP™) designed as an electronic replacement for mechanical potentiometers and trim pots. Ideal for automated adjustments on high volume production lines, they are also well suited for applications where equipment requiring periodic adjustment is either difficult to access or located in a hazardous or remote environment.

The CAT5128 contains a 32-tap series resistor array connected between two terminals A and B. An up/down counter and decoder that are controlled by two input pins, determines which tap is connected to the wiper, W. Wiper-control of the CAT5128 is accomplished with two input control pins, \overline{UP} and \overline{DOWN} . A high-to-low transition on the \overline{UP} input increments the wiper position and a high-to-low transition on the \overline{DOWN} input decrements the wiper position. The tap position is not stored in memory. The wiper is always set to the mid point, tap 15 at power up.

The digitally programmable potentiometer can be used as a three-terminal resistive divider or as a two-terminal variable resistor. DPPs bring variability and programmability to a wide variety of applications including control, parameter adjustments, and signal processing.

Features

- 32-position Linear Taper Potentiometer
- Low Power CMOS Technology
- Single Supply Operation: 2.5 V – 5.5 V
- Discrete Step-up/Step-down Digital Control
- Resistance Values: 10 k Ω , 50 k Ω and 100 k Ω
- Available in SOT-23 8-lead Package
- These Devices are Pb-Free, Halogen Free/BFR Free and are RoHS Compliant

Applications

- Automated Product Calibration
- Remote Control Adjustments
- Offset, Gain and Zero Control
- Tamper-proof Calibrations
- Contrast, Brightness and Volume Controls
- Motor Controls and Feedback Systems
- Programmable Analog Functions



ON Semiconductor®

<http://onsemi.com>

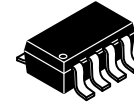

SOT-23
TB SUFFIX
CASE 527AK

PIN CONFIGURATION

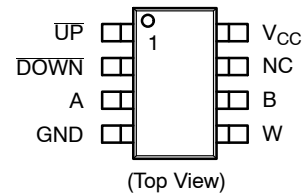

MARKING DIAGRAM

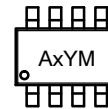

x = H, B or C
AH = CAT5128TBI-00GT3
AB = CAT5128TBI-10GT3
AC = CAT5128TBI-50GT3
Y = Production Year (Last Digit)
M = Production Month (1-9, O, N, D)

PIN DESCRIPTIONS

Pin Name	Function
\overline{UP}	Step-Up Control
\overline{DOWN}	Step-Down Control
A	Potentiometer High Terminal
GND	Ground
W	Wiper Terminal
B	Potentiometer Low Terminal
NC	Not Connected
V _{CC}	Supply Voltage

ORDERING INFORMATION

See detailed ordering and shipping information in the package dimensions section on page 7 of this data sheet.

Functional Diagrams

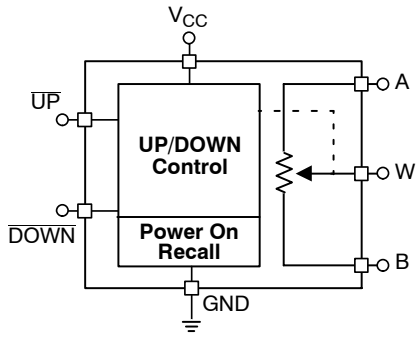

Figure 1. General

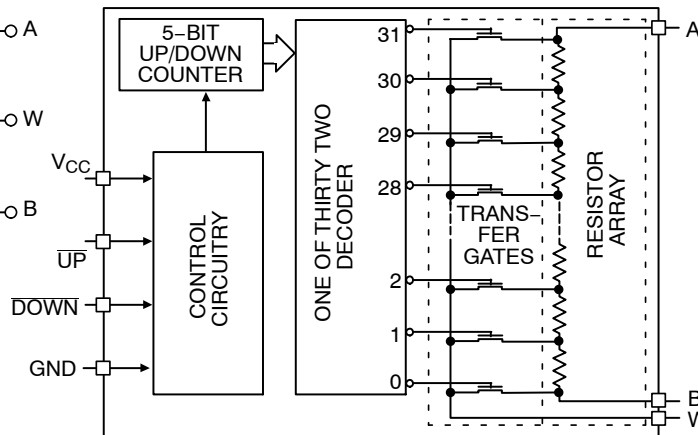

Figure 2. Detailed

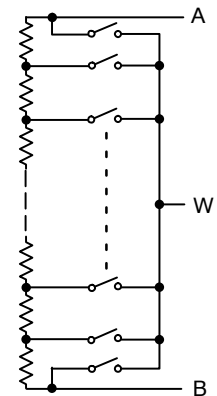

Figure 3. Electronic Potentiometer Implementation

Pin Description

UP: Step-Up Control Input

When **DOWN** input is high, a high-to-low transition on **UP** input will cause the wiper to move one increment toward the A terminal.

DOWN: Step-Down Control Input

A high-to-low transition on **DOWN** input will cause the wiper to move one increment towards the B terminal.

A: High End Potentiometer Terminal

A is the high end terminal of the potentiometer. It is not required that this terminal be connected to a potential greater than the B terminal. Voltage applied to the A terminal cannot exceed the supply voltage, V_{CC} or go below ground, GND.

W: Wiper Potentiometer Terminal

W is the wiper terminal of the potentiometer. Its position on the resistor array is controlled by the control inputs, **UP** and **DOWN**. Voltage applied to the W terminal cannot exceed the supply voltage, V_{CC} or go below ground, GND.

B: Low End Potentiometer Terminal

B is the low end terminal of the potentiometer. It is not required that this terminal be connected to a potential less than the A terminal. Voltage applied to the B terminal cannot exceed the supply voltage, V_{CC} or go below ground, GND. B and A are electrically interchangeable.

Device Operation

The CAT5128 operates like a digitally controlled potentiometer with A and B equivalent to the high and low terminals and W equivalent to the mechanical potentiometer's wiper. There are 32 available tap positions including the resistor end points, A and B. There are 31 resistor elements connected in series between the A and B terminals. The wiper terminal is connected to one of the 32 taps and controlled by two inputs, **UP** and **DOWN**. These inputs control a five-bit up/down counter whose output is decoded to select the wiper position.

A high-to-low transition on **DOWN** input will decrement one step the wiper position (R_{WB} will decrease with 1LSB and R_{WA} will increase with 1LSB). If and only if **DOWN** input is high, a high-to-low transition on **UP** input will increment one step the wiper position (R_{WB} will increase with 1LSB and R_{WA} will decrease with 1LSB).

The wiper, when at either fixed terminal, acts like its mechanical equivalent and does not move beyond the last position. When the CAT5128 is powered-down, the wiper position is reset. When power is restored, the counter is set to the mid point, tap 15.

Table 1. OPERATION MODES

UP	DOWN	Operation
High to Low	High	Wiper toward A – R_W Increment
X	Low	Wiper does not change
High	High to Low	Wiper toward B – R_W Decrement
High to Low	High to Low	Wiper toward B – R_W Decrement
Low	X	Wiper does not change
High	High	Wiper does not change

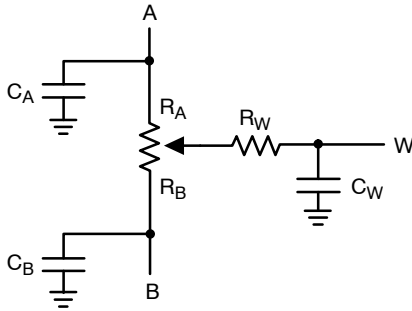

Figure 4. Potentiometer Equivalent Circuit

Table 2. ABSOLUTE MAXIMUM RATINGS

Parameters	Ratings	Units
Supply Voltage V_{CC} to GND	-0.5 to +7 V	V
Inputs UP to GND DOWN to GND A, B, W to GND	-0.5 to $V_{CC} + 0.5$ -0.5 to $V_{CC} + 0.5$ -0.5 to $V_{CC} + 0.5$	V
Operating Ambient Temperature Industrial ('I' suffix)	-40 to +85	°C
Junction Temperature	+150	°C
Storage Temperature	-65 to 150	°C
Lead Soldering (10 seconds max)	+300	°C
Thermal Resistance θ_{JA}	230	°C/W

Stresses exceeding Maximum Ratings may damage the device. Maximum Ratings are stress ratings only. Functional operation above the Recommended Operating Conditions is not implied. Extended exposure to stresses above the Recommended Operating Conditions may affect device reliability.

Table 3. DC ELECTRICAL CHARACTERISTICS ($V_{CC} = +2.5$ V to +5.5 V unless otherwise specified)

Symbol	Parameter	Conditions	Min	Typ	Max	Units
POWER SUPPLY						
V_{CC}	Operating Voltage Range		2.5	–	5.5	V
I_{CC1}	Supply Current (Increment)	$V_{CC} = 5.5$ V, $f = 1$ MHz, $I_W = 0$	–	–	100	μ A
		$V_{CC} = 5.5$ V, $f = 250$ kHz, $I_W = 0$	–	–	50	μ A
I_{SB1} (Note 1)	Supply Current (Standby)	UP, DOWN = V_{CC} or GND	–	0.01	1	μ A

1. These parameters are periodically sampled and are not production tested.

CAT5128

Table 4. LOGIC INPUTS ($V_{CC} = +2.5\text{ V}$ to $+5.5\text{ V}$ unless otherwise specified)

Symbol	Parameter	Conditions	Min	Typ	Max	Units
I_{IH}	Input Leakage Current	$V_{IN} = V_{CC}$	–	–	10	μA
I_{IL}	Input Leakage Current	$V_{IN} = 0\text{ V}$	–	–	–10	μA
V_{IH1}	TTL High Level Input Voltage	$4.5\text{ V} \leq V_{CC} \leq 5.5\text{ V}$	2	–	V_{CC}	V
V_{IL1}	TTL Low Level Input Voltage		0	–	0.8	V
V_{IH2}	CMOS High Level Input Voltage	$2.5\text{ V} \leq V_{CC} \leq 5.5\text{ V}$	$V_{CC} \times 0.7$	–	$V_{CC} + 0.3$	V
V_{IL2}	CMOS Low Level Input Voltage		–0.3	–	$V_{CC} \times 0.2$	V

Table 5. POTENTIOMETER CHARACTERISTICS ($V_{CC} = +2.5\text{ V}$ to $+5.5\text{ V}$ unless otherwise specified)

Symbol	Parameter	Conditions	Min	Typ (Note 2)	Max	Units
R_{POT}	Potentiometer Resistance	–10 Device		10		k Ω
		–50 Device		50		
		–00 Device		100		
	Pot. Resistance Tolerance				± 20	%
V_A	Voltage on A pin		0		V_{CC}	V
V_B	Voltage on B pin		0		V_{CC}	V
	Resolution			3.2		%
INL	Integral Linearity Error	$I_W \leq 2\ \mu\text{A}$	–0.5	0.1	0.5	LSB
DNL	Differential Linearity Error	$I_W \leq 2\ \mu\text{A}$	–0.5	0.05	0.5	LSB
R_{WI}	Wiper Resistance	$V_{CC} = 5\text{ V}, I_W = 1\text{ mA}$		70		Ω
		$V_{CC} = 2.5\text{ V}, I_W = 1\text{ mA}$		150	300	Ω
I_W	Wiper Current	(Note 3)			1	mA
TC_{RPOT}	TC of Pot Resistance	(Note 4)		50		ppm/ $^{\circ}\text{C}$
TC_{RATIO}	Ratiometric TC	(Note 4)		5	20	ppm/ $^{\circ}\text{C}$
V_N (Note 4)	Noise	100 kHz / 1 kHz		8/24		nV/ $\sqrt{\text{Hz}}$
$C_A/C_B/C_W$	Potentiometer Capacitances	(Note 4)		8/8/25		pF
f_c (Note 4)	Frequency Response	Passive Attenuator, 10 k Ω		1.7		MHz

2. Typical values are for $T_A = 25^{\circ}\text{C}$ and nominal supply voltage.

3. I_W = source or sink.

4. These parameters are periodically sampled and are not production tested.

Table 6. AC CONDITIONS OF TEST

V_{CC} Range	$2.5\text{ V} \leq V_{CC} \leq 5.5\text{ V}$
Input Pulse Levels	$0.2 V_{CC}$ to $0.7 V_{CC}$
Input Rise and Fall Times	10 ns
Input Reference Levels	$0.5 V_{CC}$

Table 7. AC OPERATING CHARACTERISTICS ($V_{CC} = +2.5\text{ V}$ to $+5.5\text{ V}$, $V_H = V_{CC}$, $V_L = 0\text{ V}$, unless otherwise specified)

Symbol	Parameter	Min	Typ (Note 5)	Max	Units
t_{UP}	UP LOW Period	500	–	–	ns
t_{DOWN}	DOWN LOW Period	500	–	–	ns
t_{UP_CYC}	UP Cycle Time	1	–	–	μs
t_{DOWN_CYC}	DOWN Cycle Time	1	–	–	μs
t_{UP_R}, t_{UP_F} (Note 6)	UP Rise and Fall Time	–	–	500	ns
t_{DOWN_R}, t_{DOWN_F} (Note 6)	DOWN Rise and Fall Time	–	–	500	ns
t_{UP_SET}	UP Settling Time	200	–	–	ns
t_{DOWN_SET}	DOWN Settling Time	200	–	–	ns
t_{PU} (Note 6)	Power-up to Wiper Stable	–	–	1	ms

5. Typical values are for $T_A = 25^\circ\text{C}$ and nominal supply voltage.

6. This parameter is periodically sampled and not 100% tested.

Interface Timing Diagrams

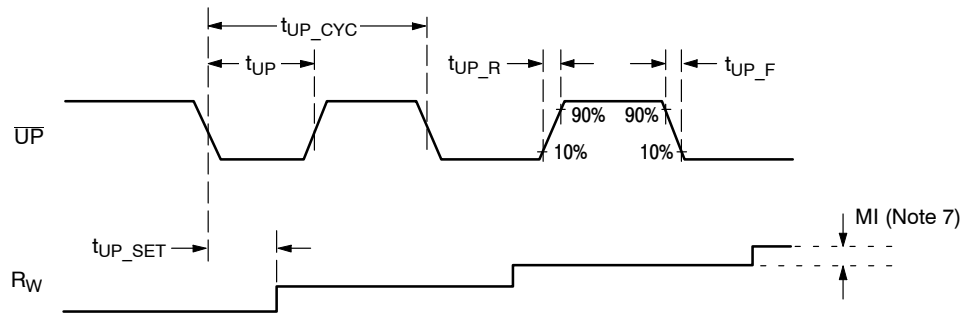

Figure 5. Increment R_W in Discrete Steps

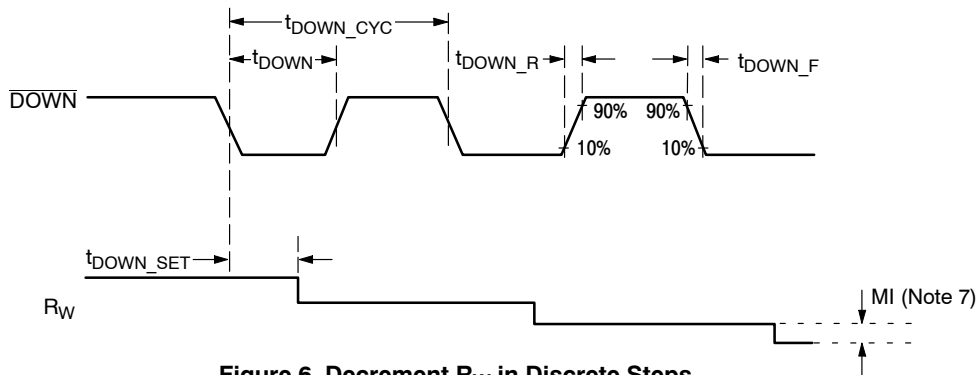

Figure 6. Decrement R_W in Discrete Steps

7. MI in the A.C. Timing diagram refers to the minimum incremental change in the W output due to a change in the wiper position.

CAT5128

PACKAGE DIMENSIONS

SOT-23, 8 Lead
CASE 527AK-01
ISSUE A

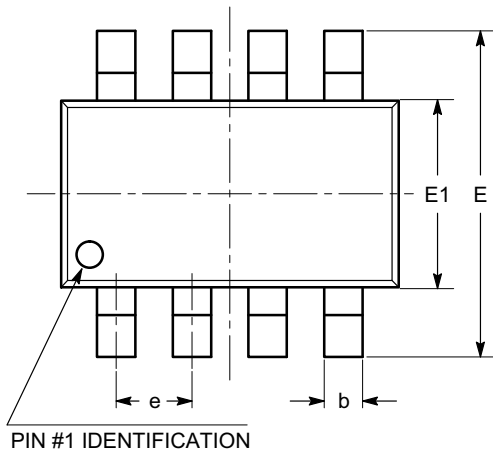

TOP VIEW

SYMBOL	MIN	NOM	MAX
A	0.90		1.45
A1	0.00		0.15
A2	0.90	1.10	1.30
A3	0.60		0.80
b	0.28		0.38
c	0.08		0.22
D	2.90 BSC		
E	2.80 BSC		
E1	1.60 BSC		
e	0.65 BSC		
L	0.30	0.45	0.60
L1	0.60 REF		
L2	0.25 REF		
θ	0°		8°

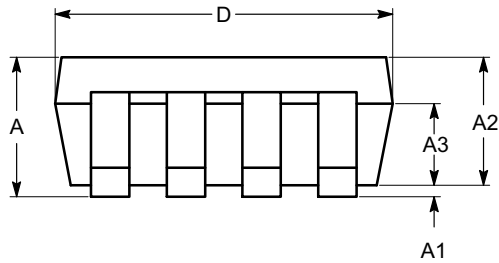

SIDE VIEW

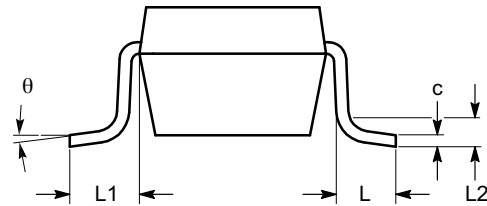

END VIEW

Notes:

- (1) All dimensions in millimeters. Angles in degrees.
- (2) Complies with JEDEC standard MO-178.

CAT5128

Example of Ordering Information (Note 10)

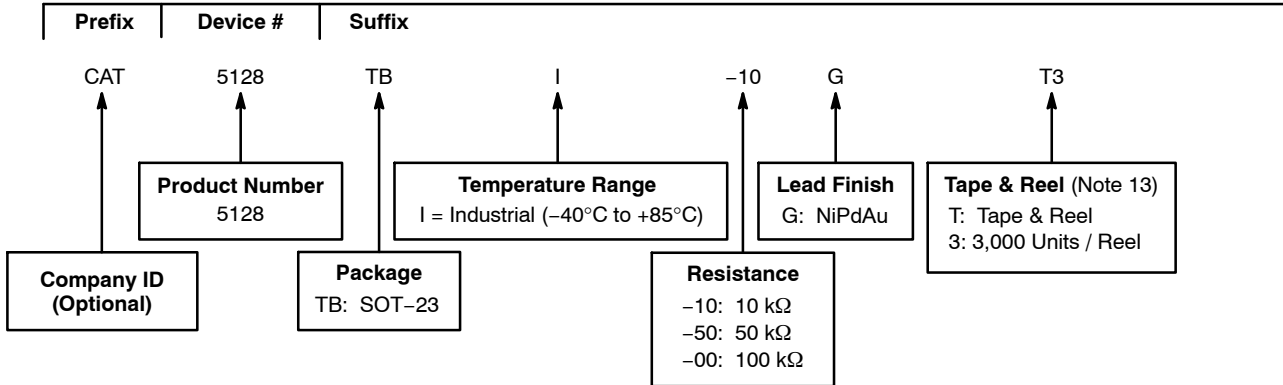

Table 8. ORDERING INFORMATION

Orderable Part Number	Resistance (kΩ)	Package	Lead Finish
CAT5128TBI-10GT3	10	SOT-23-8	NiPdAu
CAT5128TBI-50GT3	50		
CAT5128TBI-00GT3 (Note 12)	100		

8. All packages are RoHS-compliant (Lead-free, Halogen-free).

9. The standard lead finish is NiPdAu.

10. The device used in the above example is a CAT5128TBI-10GT3 (SOT-23, Industrial Temperature, 10 kΩ, NiPdAu, Tape & Reel, 3,000/Reel).

11. For additional package and temperature options, please contact your nearest ON Semiconductor Sales office.

12. Contact factory for availability.

13. For information on tape and reel specifications, including part orientation and tape sizes, please refer to our Tape and Reel Packaging Specifications Brochure, BRD8011/D.

DPP is a trademark of Semiconductor Components Industries, LLC.

ON Semiconductor and are registered trademarks of Semiconductor Components Industries, LLC (SCILLC). SCILLC reserves the right to make changes without further notice to any products herein. SCILLC makes no warranty, representation or guarantee regarding the suitability of its products for any particular purpose, nor does SCILLC assume any liability arising out of the application or use of any product or circuit, and specifically disclaims any and all liability, including without limitation special, consequential or incidental damages. "Typical" parameters which may be provided in SCILLC data sheets and/or specifications can and do vary in different applications and actual performance may vary over time. All operating parameters, including "Typicals" must be validated for each customer application by customer's technical experts. SCILLC does not convey any license under its patent rights nor the rights of others. SCILLC products are not designed, intended, or authorized for use as components in systems intended for surgical implant into the body, or other applications intended to support or sustain life, or for any other application in which the failure of the SCILLC product could create a situation where personal injury or death may occur. Should Buyer purchase or use SCILLC products for any such unintended or unauthorized application, Buyer shall indemnify and hold SCILLC and its officers, employees, subsidiaries, affiliates, and distributors harmless against all claims, costs, damages, and expenses, and reasonable attorney fees arising out of, directly or indirectly, any claim of personal injury or death associated with such unintended or unauthorized use, even if such claim alleges that SCILLC was negligent regarding the design or manufacture of the part. SCILLC is an Equal Opportunity/Affirmative Action Employer. This literature is subject to all applicable copyright laws and is not for resale in any manner.

PUBLICATION ORDERING INFORMATION

LITERATURE FULFILLMENT:

Literature Distribution Center for ON Semiconductor
P.O. Box 5163, Denver, Colorado 80217 USA
Phone: 303-675-2175 or 800-344-3860 Toll Free USA/Canada
Fax: 303-675-2176 or 800-344-3867 Toll Free USA/Canada
Email: orderlit@onsemi.com

N. American Technical Support: 800-282-9855 Toll Free
USA/Canada
Europe, Middle East and Africa Technical Support:
Phone: 421 33 790 2910
Japan Customer Focus Center
Phone: 81-3-5773-3850

ON Semiconductor Website: www.onsemi.com

Order Literature: <http://www.onsemi.com/orderlit>

For additional information, please contact your local Sales Representative