

HIGH FREQUENCY MAGNETICS

T1/E1 Through Hole Transformers

TM00118

- Operates as a line-interface pulse transformer in DS1 and CEPT applications
- Contains specific interwinding insulation to minimize capacitance
- Winding (3-2)(2-1) is highly balanced
- Designed for automatic machine placement into printed wiring boards
- Only difference between the 2745AF and 2745AF2 is the terminal length
- Operating temperature range: -40°C to +85°C
- Meets IEC 695, 2-2 flammability requirements
- PWB Process Capability: standard printed wiring board assembly techniques, total-immersion cleaning
- Reliability testing: Shock, vibration, temperature cycling, temperature - humidity - bias

ELECTRICAL SPECIFICATIONS AT 25° C

Part Number	Turns Ratio ± 2%	Inductance ¹ mH min	DCR Ω max		Leakage Inductance ² μH max	Interwinding Capacitance pF max	Minimum Interwinding Breakdown Voltage Vrms
	(3-1) : (4-6)	(3-1)	(3-1)	(4-6)	(3-1)	(3-1) and (4-6)	
2745AF	1CT : 2 CT	3.15	1.55	3.15	3.0	23	1000
2745AF2	1CT : 2 CT	3.15	1.55	3.15	3.0	23	1000

1. measured at 19 kHz, 0.1V

2. measured at 100kHz, with (4-6) shorted

Typical Frequency and Time Response				
Terminating Impedances	Bandwidth (3 dB)	Risetime	Overshoot	Droop (350 ns pulse)
100 Ω : 400 Ω	2 kHz - 21 MHz	17 ns	0 %	0.5%

SCHEMATIC

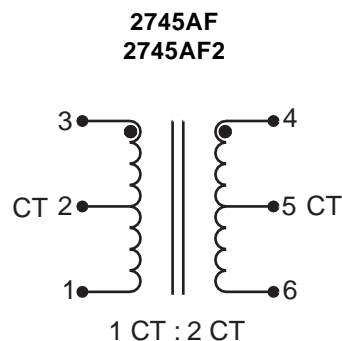

TM00118

MECHANICAL

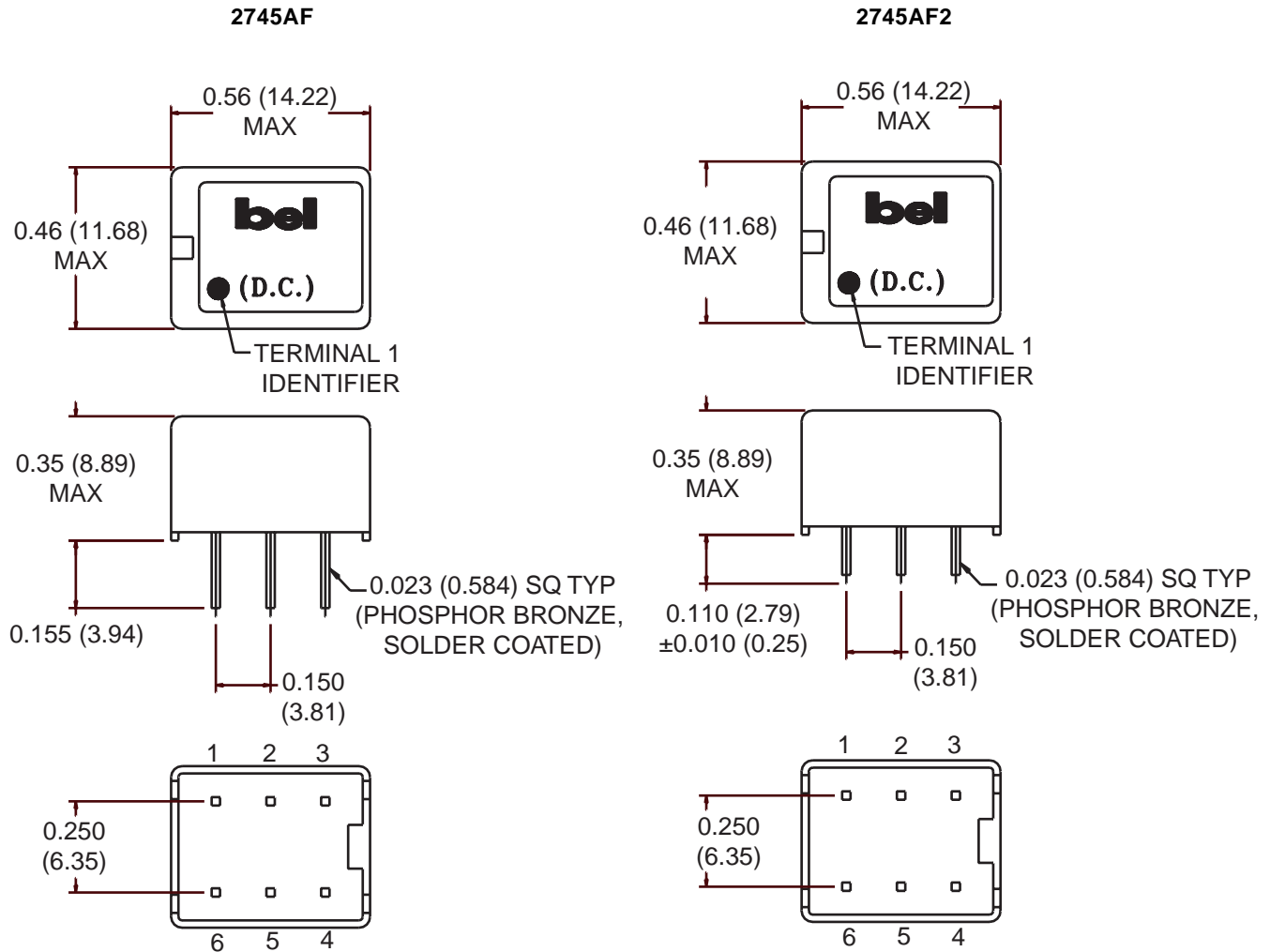

Unless otherwise specified, dimensions are nominal and in inches (millimeters).

©2000 Bel Fuse Inc. Specifications subject to change without notice. 09.00

CORPORATE

Bel Fuse Inc.
 198 Van Vorst Street
 Jersey City, NJ 07302
 Tel 201-432-0463
 Fax 201-432-9542
 www.belfuse.com

T1-42

FAR EAST

Bel Fuse Ltd.
 8F / 8 Luk Hop Street
 San Po Kong
 Kowloon, Hong Kong
 Tel 852-2328-5515
 Fax 852-2352-3706
 www.belfuse.com

EUROPE

Bel Fuse Europe Ltd.
 Preston Technology Management Centre
 Marsh Lane, Suite G7, Preston
 Lancashire, PR1 8UD, U.K.
 Tel 44-1772-556601
 Fax 44-1772-888366
 www.belfuse.com