

Smart High-Side Power Switch

1 Channel: 1 x 200mΩ



Features

- Short circuit protection
- Current limitation
- Overload protection
- Overvoltage protection (including load dump)
- Undervoltage shutdown with auto-restart and hysteresis
- Switching inductive loads
- Clamp of negative voltage at output with inductive loads
- CMOS compatible input
- Thermal shutdown with restart
- ESD - Protection
- Loss of GND and loss of V_{bb} protection
- Very low standby current
- Reverse battery protection with external resistor
- Improved electromagnetic compatibility (EMC)
 - AEC qualified
 - Green product (RoHS compliant)

Product Summary

Overvoltage protection	$V_{bb(AZ)}$	47	V
Operating voltage	$V_{bb(on)}$	12...45	V
On-state resistance	R_{ON}	200	mΩ

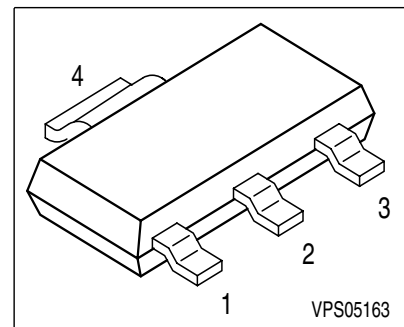

PG-SOT-223

Application

- All types of resistive, inductive and capacitive loads
- μ C compatible power switch for 12 V and 24 V DC applications
- Replaces electromechanical relays and discrete circuits

General Description

N channel vertical power FET with charge pump, ground referenced CMOS compatible input, monolithically integrated in Smart SIPMOS® technology. Providing embedded protective functions.

Block Diagram

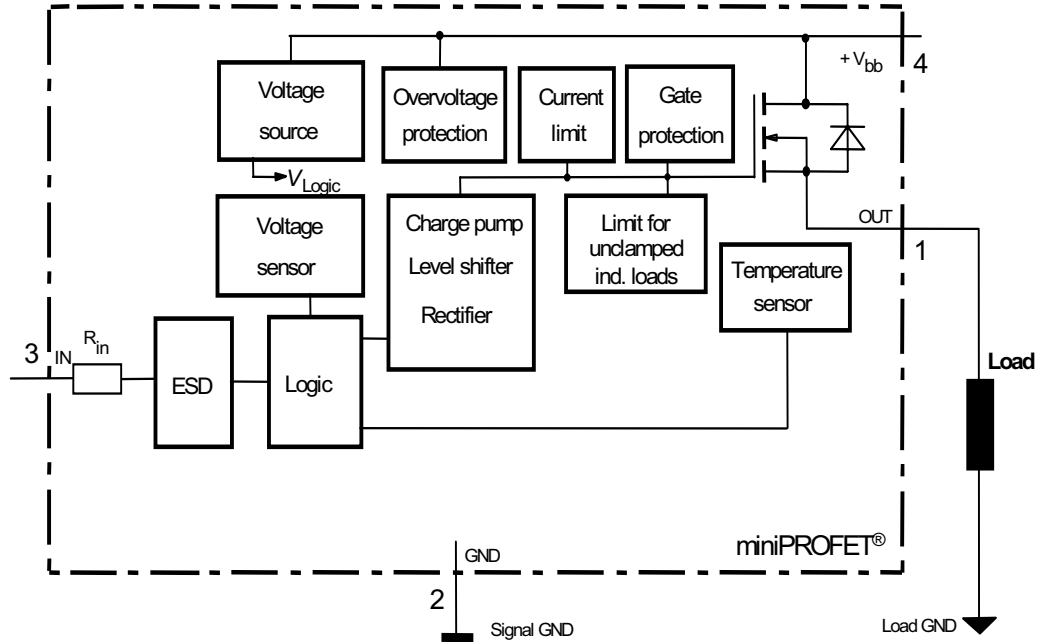

Pin	Symbol	Function
1	OUT	Output to the load
2	GND	Logic ground
3	IN	Input, activates the power switch in case of logic high signal
4	Vbb	Positive power supply voltage

Maximum Ratings

Parameter	Symbol	Value	Unit
at $T_j = 25^\circ\text{C}$, unless otherwise specified			
Supply voltage	V_{bb}	-0,31)...48	V
Continuous input voltage ²⁾	V_{IN}	-10... V_{bb}	
Load current (Short - circuit current, see page 5)	I_L	self limited	A
Current through input pin (DC)	I_{IN}	± 5	mA
Reverse current through GND-pin ³⁾	$-I_{GND}$	-0.5	A
Operating temperature	T_j	internal limited	$^\circ\text{C}$
Storage temperature	T_{stg}	-55 ... +150	
Power dissipation ⁴⁾	P_{tot}	1.4	W
Inductive load switch-off energy dissipation ⁴⁾⁵⁾ single pulse $T_j = 125^\circ\text{C}$, $I_L = 1\text{ A}$	E_{AS}	0.16	J
Load dump protection ⁵⁾ $V_{LoadDump}^{6)} = V_A + V_S$ $R_I = 2\Omega$, $t_d = 400\text{ms}$, $V_{IN} = \text{low or high}$, $V_A = 13,5\text{V}$ $R_L = 47\ \Omega$	$V_{Loaddump}$	83	V
Electrostatic discharge voltage (Human Body Model) according to ANSI EOS/ESD - S5.1 - 1993 ESD STM5.1 - 1998	V_{ESD}		kV
Input pin		± 1	
All other pins		± 5	

¹defined by P_{tot}

²At $V_{IN} > V_{bb}$, the input current is not allowed to exceed $\pm 5\text{ mA}$.

³defined by P_{tot}

⁴Device on 50mm*50mm*1.5mm epoxy PCB FR4 with 6 cm² (one layer, 70 μm thick) copper area for V_{bb} connection. PCB is vertical without blown air.

⁵not subject to production test, specified by design

⁶ $V_{Loaddump}$ is setup without the DUT connected to the generator per ISO 7637-1 and DIN 40839 .

Supply voltages higher than $V_{bb(AZ)}$ require an external current limit for the GND pin, e.g. with a 150 Ω resistor in GND connection. A resistor for the protection of the input is integrated.

Electrical Characteristics

Parameter at $T_j = -40...125\text{ }^\circ\text{C}$, $V_{bb} = 15...30\text{ V}$ unless otherwise specified	Symbol	Values			Unit
		min.	typ.	max.	

Thermal Characteristics

Thermal resistance @ min. footprint	$R_{th(JA)}$	-	-	125	K/W
Thermal resistance @ 6 cm ² cooling area ¹⁾	$R_{th(JA)}$	-	-	70	
Thermal resistance, junction - soldering point	$R_{th(JS)}$	-	-	7	K/W

Load Switching Capabilities and Characteristics

On-state resistance $T_j = 25\text{ }^\circ\text{C}$, $I_L = 0.5\text{ A}$ $T_j = 125\text{ }^\circ\text{C}$	R_{ON}	-	150	200	m Ω
		-	270	320	
Nominal load current ²⁾ Device on PCB ¹⁾	$I_{L(nom)}$	1.4	-	-	A
Turn-on time to 90% V_{OUT} $R_L = 47\text{ }\Omega$, $V_{IN} = 0\text{ to }10\text{ V}$	t_{on}	-	50	100	μs
Turn-off time to 10% V_{OUT} $R_L = 47\text{ }\Omega$, $V_{IN} = 10\text{ to }0\text{ V}$	t_{off}	-	75	150	
Slew rate on 10 to 30% V_{OUT} , $R_L = 47\text{ }\Omega$, $V_{bb} = 15\text{ V}$	dV/dt_{on}	-	1	2	V/ μs
Slew rate off 70 to 40% V_{OUT} , $R_L = 47\text{ }\Omega$, $V_{bb} = 15\text{ V}$	$-dV/dt_{off}$	-	1	2	

¹Device on 50mm*50mm*1.5mm epoxy PCB FR4 with 6 cm² (one layer, 70 μm thick) copper area for V_{bb} connection. PCB is vertical without blown air.

²Nominal load current is limited by the current limitation (see page 5)

Electrical Characteristics

Parameter at $T_j = -40...125\text{ }^\circ\text{C}$, $V_{bb} = 15...30\text{ V}$ unless otherwise specified	Symbol	Values			Unit
		min.	typ.	max.	

Operating Parameters

Operating voltage	$V_{bb(on)}$	12	-	45	V
Undervoltage shutdown	$V_{bb(under)}$	7	-	10.5	
Undervoltage restart	$V_{bb(u\text{ rst})}$	-	-	11	
Undervoltage hysteresis $\Delta V_{bb(under)} = V_{bb(u\text{ rst})} - V_{bb(under)}$	$\Delta V_{bb(under)}$	-	0.5	-	
Standby current $T_j = -40...85\text{ }^\circ\text{C}$, $V_{IN} \leq 1,2\text{ V}$ $T_j = 125\text{ }^\circ\text{C}^1)$	$I_{bb(off)}$	-	10	25	μA
Operating current	I_{GND}	-	1	1.6	mA
Leakage output current (included in $I_{bb(off)}$) $V_{IN} \leq 1,2\text{ V}$	$I_{L(off)}$	-	3.5	10	μA

Protection Functions²⁾

Initial peak short circuit current limit $T_j = -40\text{ }^\circ\text{C}$, $V_{bb} = 20\text{ V}$, $t_m = 150\text{ }\mu\text{s}$ $T_j = 25\text{ }^\circ\text{C}$ $T_j = 125\text{ }^\circ\text{C}$	$I_{L(SCp)}$	-	-	4.5	A
Repetitive short circuit current limit $T_j = T_{jt}$ (see timing diagrams)	$I_{L(SCr)}$	-	2.2	-	
Output clamp (inductive load switch off) at $V_{OUT} = V_{bb} - V_{ON(CL)}$, $I_{bb} = 4\text{ mA}$	$V_{ON(CL)}$	62	68	-	V
Overvoltage protection ³⁾ $I_{bb} = 4\text{ mA}$	$V_{bb(AZ)}$	47	-	-	
Thermal overload trip temperature ⁴⁾	T_{jt}	135	-	-	$^\circ\text{C}$
Thermal hysteresis	ΔT_{jt}	-	10	-	K

¹⁾higher current due temperature sensor

²⁾Integrated protection functions are designed to prevent IC destruction under fault conditions described in the data sheet. Fault conditions are considered as "outside" normal operating range. Protection functions are not designed for continuous repetitive operation.

³⁾see also $V_{ON(CL)}$ in circuit diagram

⁴⁾ higher operating temperature at normal function available

Electrical Characteristics

Parameter	Symbol	Values			Unit
		min.	typ.	max.	
at $T_j = -40 \dots 125 \text{ }^\circ\text{C}$, $V_{bb} = 15 \dots 30 \text{ V}$ unless otherwise specified					
Input					
Continuous input voltage ¹⁾	V_{IN}	-10 ²⁾	-	V_{bb}	V
Input turn-on threshold voltage	$V_{IN(T+)}$	-	-	3.0	
Input turn-off threshold voltage	$V_{IN(T-)}$	1.82	-	-	
Input threshold hysteresis	$\Delta V_{IN(T)}$	-	0.2	-	
Off state input current $V_{IN} \leq 1,8 \text{ V}$	$I_{IN(off)}$	20	-	-	μA
On state input current	$I_{IN(on)}$	-	-	110	
Input delay time at switch on V_{bb}	$t_d(V_{bbon})$	150	340	-	μs
Input resistance (see page 8)	R_I	1.5	3	5	$\text{k}\Omega$

Reverse Battery

Reverse battery voltage ³⁾²⁾	$-V_{bb}$				V
$R_{GND} = 0 \text{ }\Omega$		-	-	0.3	
$R_{GND} = 150 \text{ }\Omega$		-	-	45	
Continuous reverse drain current ²⁾ $T_j = 25 \text{ }^\circ\text{C}$	I_S	-	-	1	A
Drain-source diode voltage ($V_{OUT} > V_{bb}$) $I_F = 1 \text{ A}$	$-V_{ON}$	-	0.6	1.2	V

¹At $V_{IN} > V_{bb}$, the input current is not allowed to exceed $\pm 5 \text{ mA}$.

²not subject to production test, guaranteed by design

³defined by P_{tot}

EMC-Characteristics

All EMC-Characteristics are based on limited number of samples and no part of production test.

Test Conditions:

If not other specified the test circuitry is the minimal functional configuration without any external components for protection or filtering.

Supply voltage:	$V_{bb} = 13.5V$	Temperature:	$T_a = 23 \pm 5^\circ C$;
Load:	$R_L = 220\Omega$		
Operation mode:	PWM DC On/Off	Frequency:	100Hz / Duty Cycle: 50%
DUT-Specific.:	R_{GND}		

Fast electrical transients

Acc. ISO 7637

Test Pulse	Test Level	Test Results		Pulse Cycle Time and Generator Impedance
		On	Off	
1	-200 V	C	C	500ms ; 10 Ω
2	+200 V	C	C	500ms ; 10 Ω
3a	-200 V	C	C	100ms ; 50 Ω
3b	+ 200 V	C	C	100ms ; 50 Ω
4 ¹⁾	-7 V	C	C	0,01 Ω
5	175 V	E (70V)	E (70V)	400ms ; 2 Ω

The test pulses are applied at V_{bb}

Definition of functional status

Class	Content
C	All functions of the device are performed as designed after exposure to disturbance.
E	One or more function of a device does not perform as designed after exposure and can not be returned to proper operation without repairing or replacing the device. The value after the character shows the limit.

Test circuit:

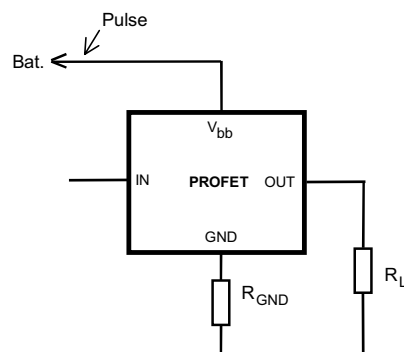

¹Supply voltage $V_{bb} = 12 V$ instead of 13,5 V.

Conducted Emission

Acc. IEC 61967-4 (1Ω / 150Ω method)

Typ. V_{bb} -Pin Emission at DC-On with 150Ω-matching network

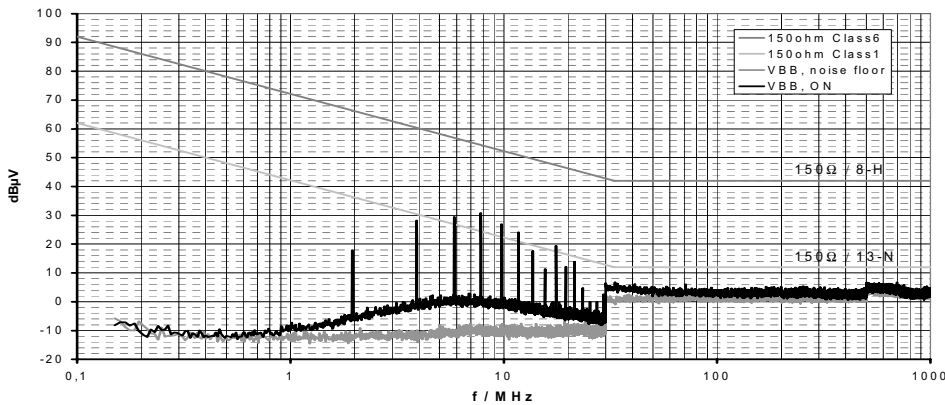

Typ. V_{bb} -Pin Emission at PWM-Mode with 150Ω-matching network

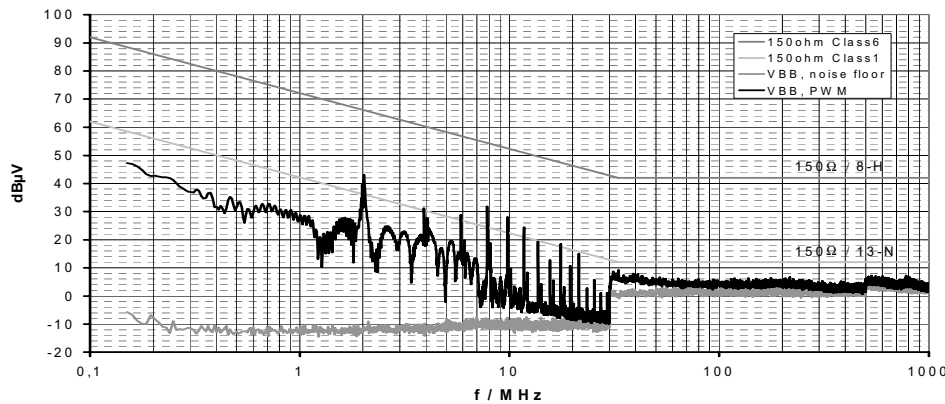

Test circuit:

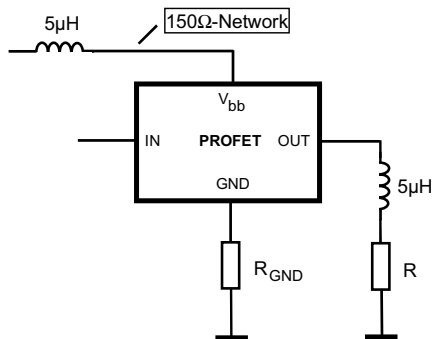

For defined decoupling and high reproducibility a defined choke (5μH at 1 MHz) is inserted between supply and V_{hh} -pin.

Conducted Susceptibility

Acc. 47A/658/CD IEC 62132-4 (Direct Power Injection)

Direct Power Injection: Forward Power CW

Failure criteria: Amplitude and frequency deviation max. 10% at Out

Typ. V_{bb} -Pin Susceptibility at DC-On/Off

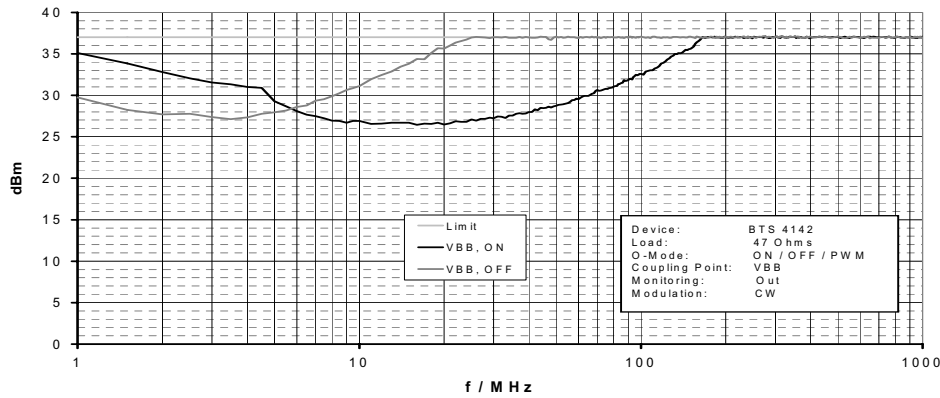

Typ. V_{bb} -Pin Susceptibility at PWM-Mode

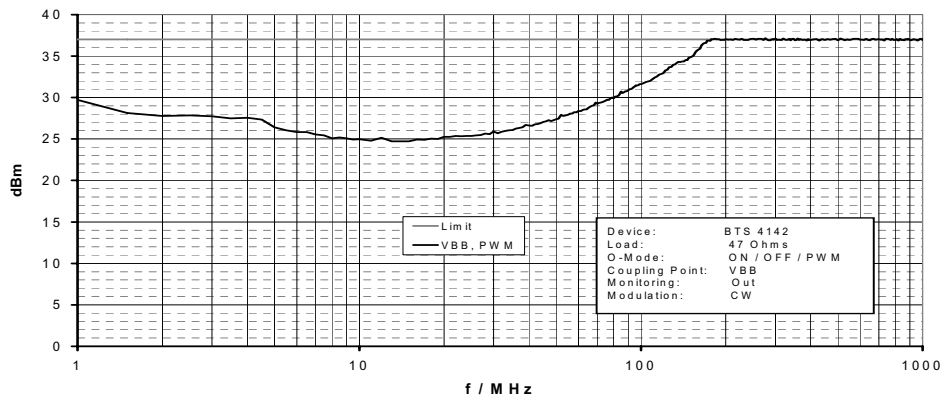

Test circuit:

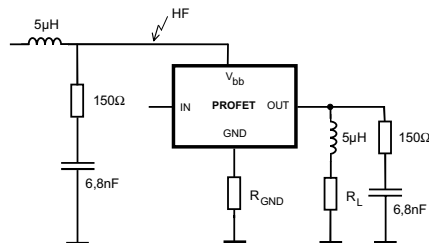

For defined decoupling and high reproducibility the same choke and the same 150Ω -matching network as for the emission measurement is used.

Terms

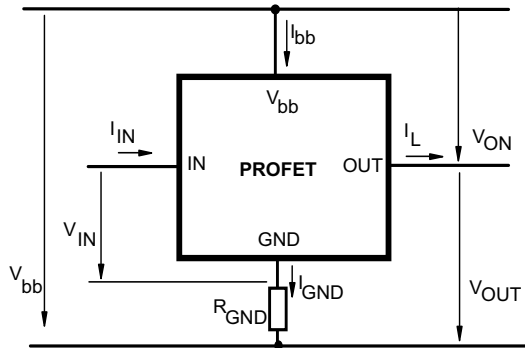

Inductive and overvoltage output clamp

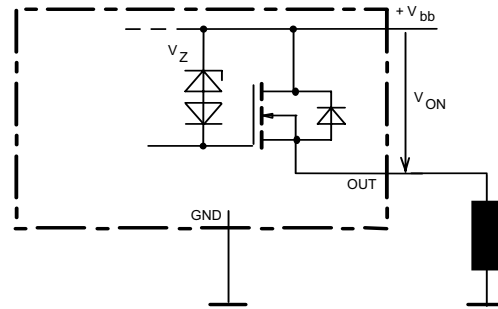

V_{ON} clamped to 63 V min.

Input circuit (ESD protection)

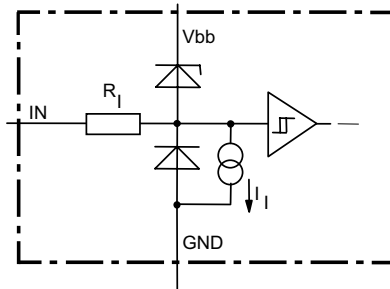

The use of ESD zener diodes as voltage clamp at DC conditions is not recommended

Overvoltage protection of logic part

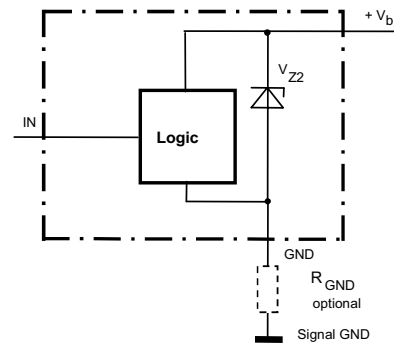

$V_{Z2}=V_{bb(AZ)}=47V$ min.,
 $R_I=3\text{ k}\Omega$ typ., $R_{GND}=150\Omega$

Reverse battery protection

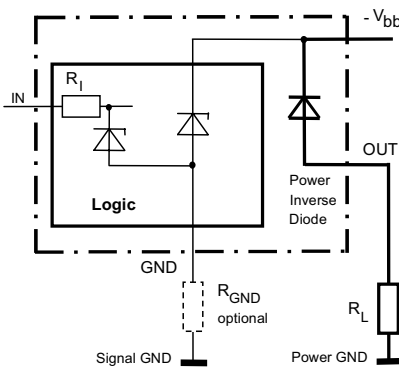

$R_{GND}=150\Omega$, $R_I=3\text{ k}\Omega$ typ.,
Temperature protection is not active during inverse current

GND disconnect

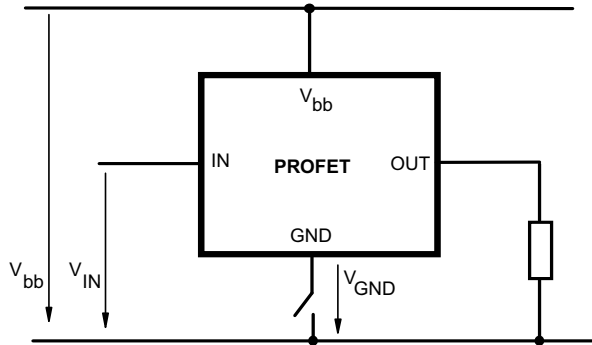

Inductive Load switch-off energy dissipation

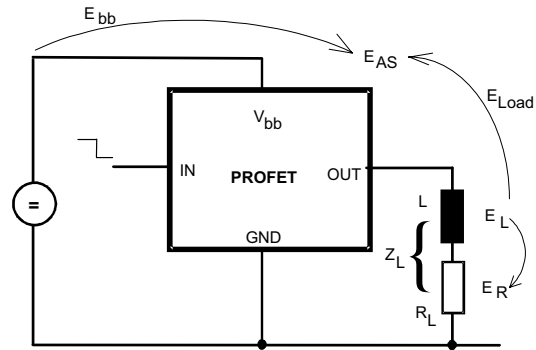

GND disconnect with GND pull up

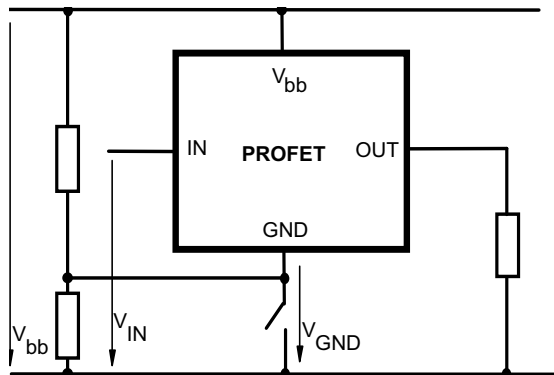

Energy stored in load inductance: $E_L = \frac{1}{2} * L * I_L^2$

While demagnetizing load inductance,

the energy dissipated in PROFET is

$$E_{AS} = E_{bb} + E_L - E_R = V_{ON(CL)} * i_L(t) dt,$$

with an approximate solution for $R_L > 0\Omega$:

$$E_{AS} = \frac{I_L * L}{2 * R_L} * (V_{bb} + |V_{OUT(CL)}|) * \ln\left(1 + \frac{I_L * R_L}{|V_{OUT(CL)}|}\right)$$

Vbb disconnect with charged inductive load

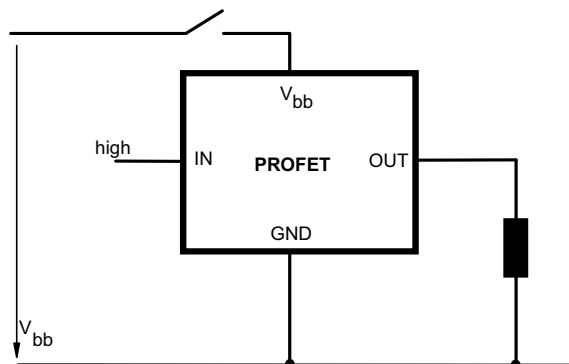

Typ. transient thermal impedance

$Z_{thJA} = f(t_p)$ @ 6cm² heatsink area

Parameter: $D = t_p / T$

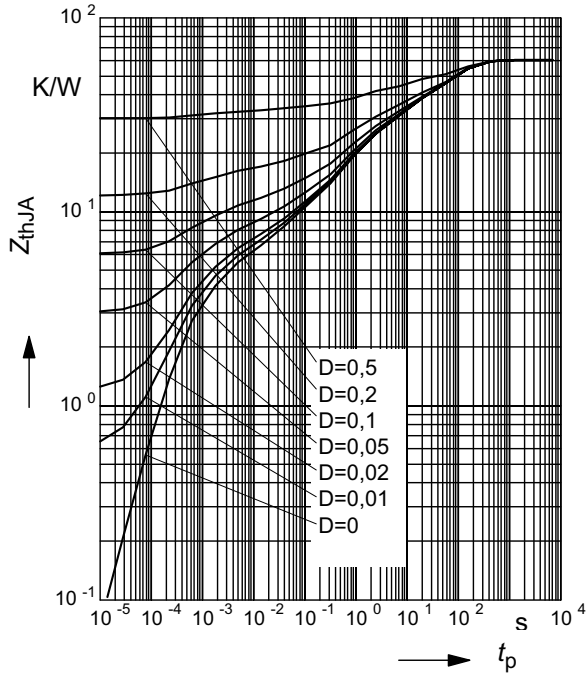

Typ. transient thermal impedance

$Z_{thJA} = f(t_p)$ @ min. footprint

Parameter: $D = t_p / T$

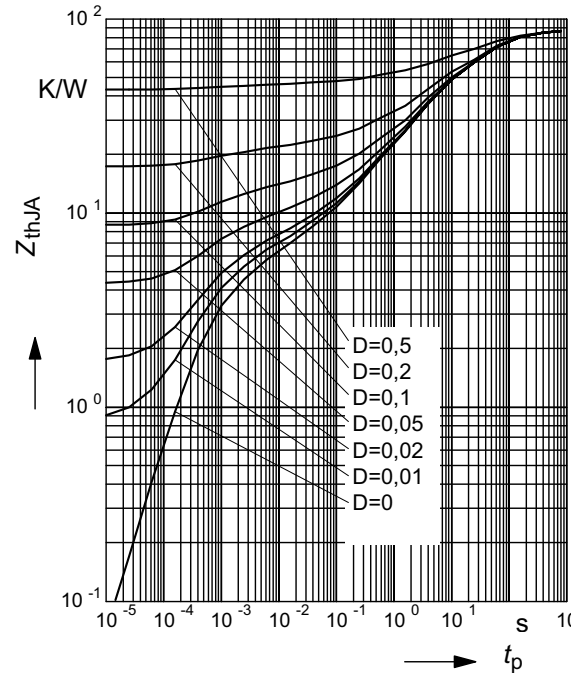

Typ. on-state resistance

$R_{ON} = f(T_j)$; $V_{bb} = 15\text{ V}$; $V_{in} = \text{high}$

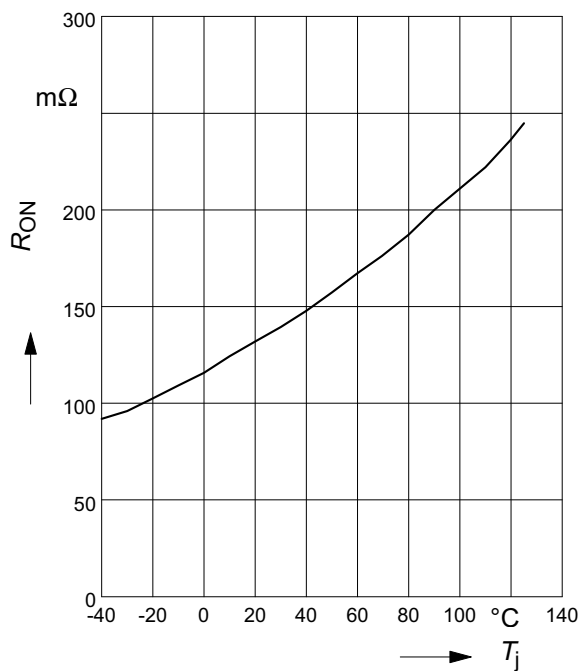

Typ. on-state resistance

$R_{ON} = f(V_{bb})$; $I_L = 0.5\text{ A}$; $V_{in} = \text{high}$

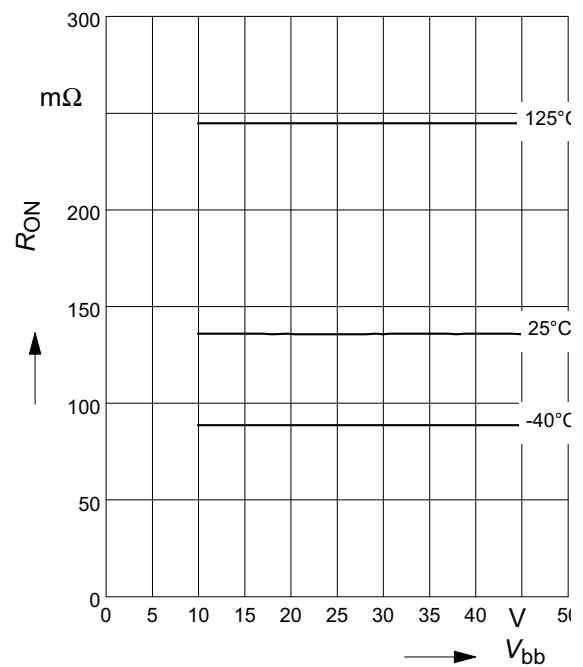

Typ. turn on time

$t_{on} = f(T_j); R_L = 47\Omega$

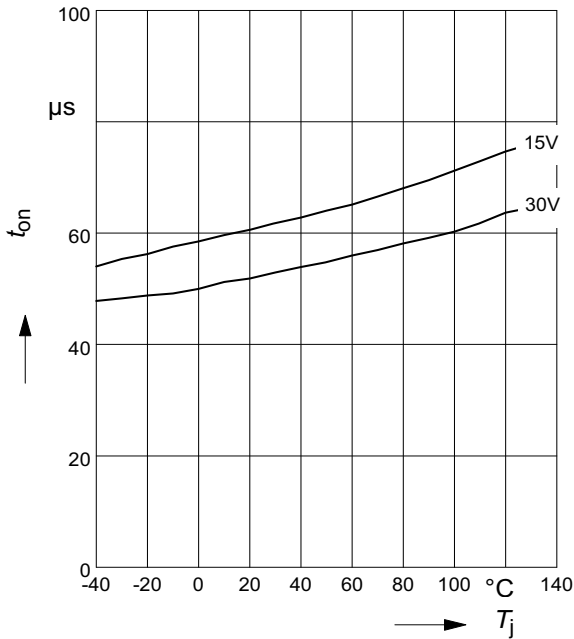

Typ. turn off time

$t_{off} = f(T_j); R_L = 47\Omega$

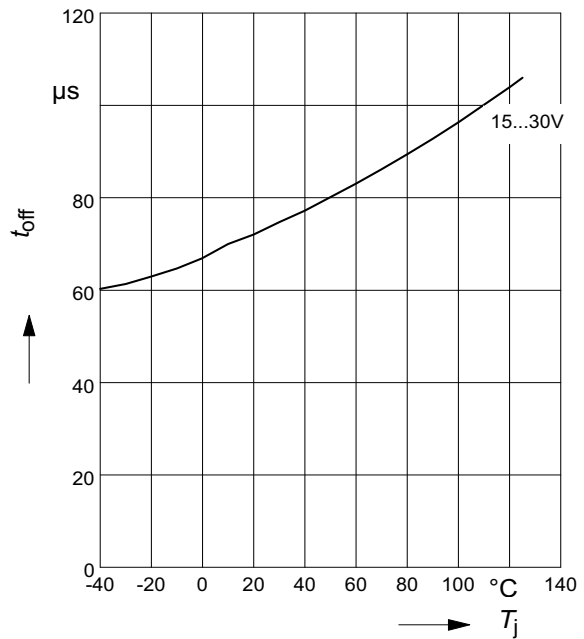

Typ. slew rate on

$dV/dt_{on} = f(T_j); R_L = 47\Omega$

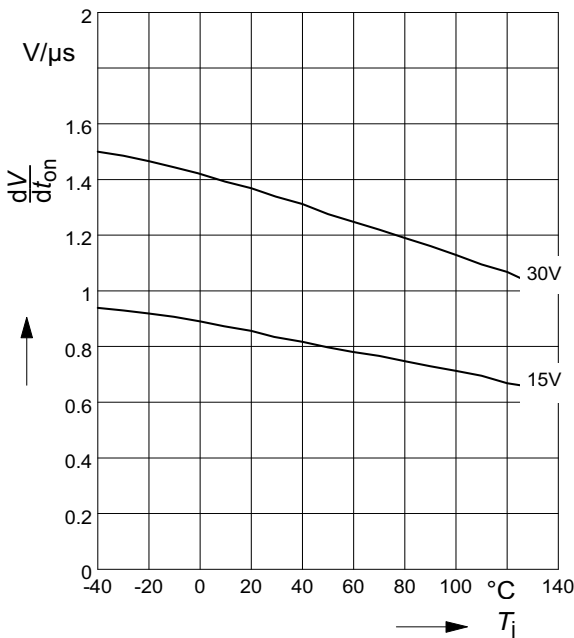

Typ. slew rate off

$-dV/dt_{off} = f(T_j); R_L = 47\Omega$

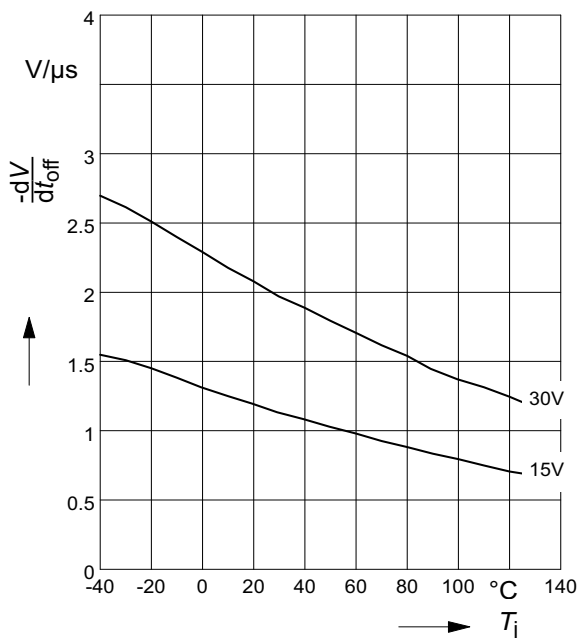

Typ. initial peak short circuit current limit

$$I_{L(SCp)} = f(T_j); V_{bb} = 20V; t_m = 150\mu s$$

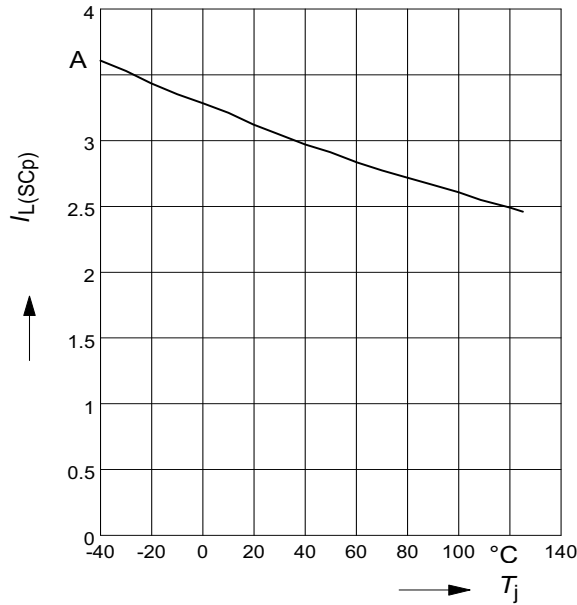

Typ. initial short circuit shutdown time

$$t_{off(SC)} = f(T_{j,start}); V_{bb} = 20V$$

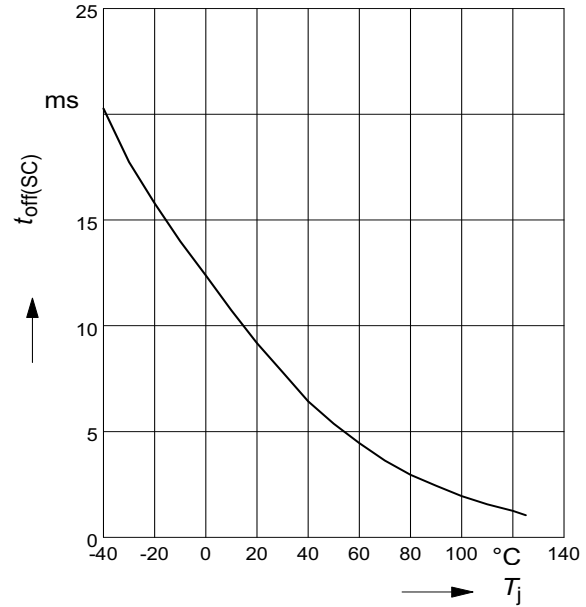

Typ. initial peak short circuit current limit

$$I_{L(SCp)} = f(V_{bb}); t_m = 150\mu s$$

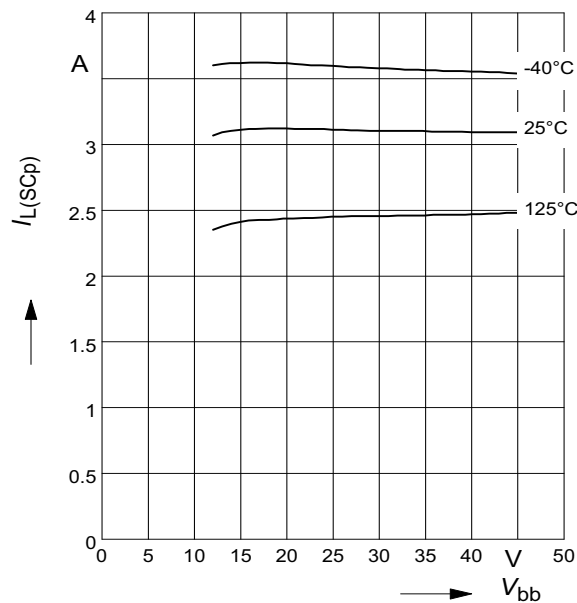

Typ. input current

$$I_{IN(on/off)} = f(T_j); V_{bb} = 15V; V_{IN} = \text{low/high}$$

$V_{INlow} \leq 1.8V; V_{INhigh} = 5V$

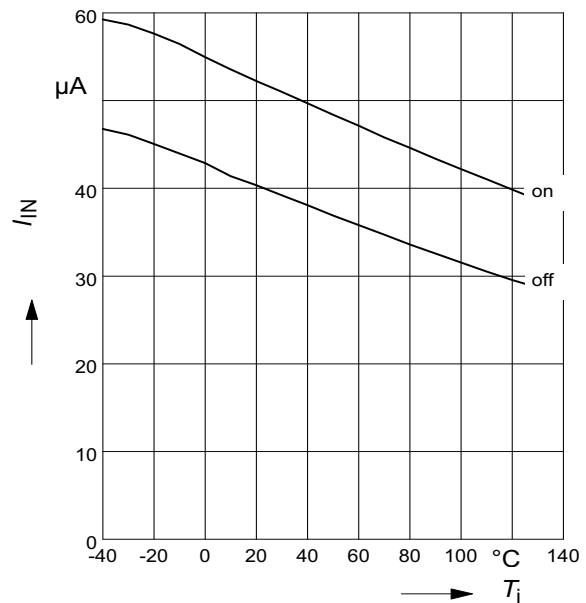

Typ. input current

$$I_{IN} = f(V_{IN}); V_{bb} = 15 \text{ V}$$

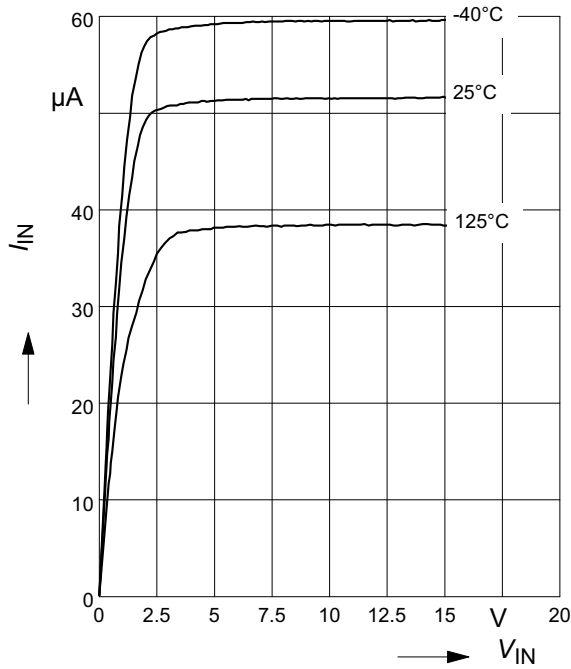

Typ. input threshold voltage

$$V_{IN(th)} = f(T_j); V_{bb} = 15 \text{ V}$$

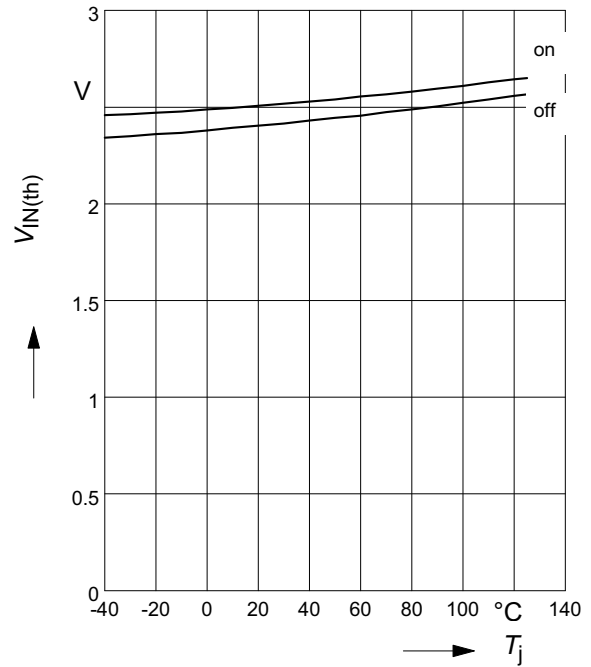

Typ. input threshold voltage

$$V_{IN(th)} = f(V_{bb}); T_j = 25^\circ\text{C}$$

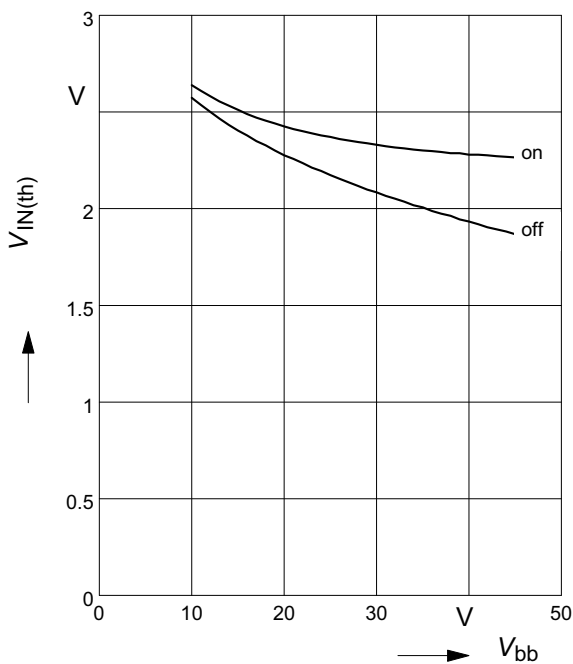

Typ. standby current

$$I_{bb(off)} = f(T_j); V_{bb} = 32 \text{ V}; V_{IN} \leq 1,2 \text{ V}$$

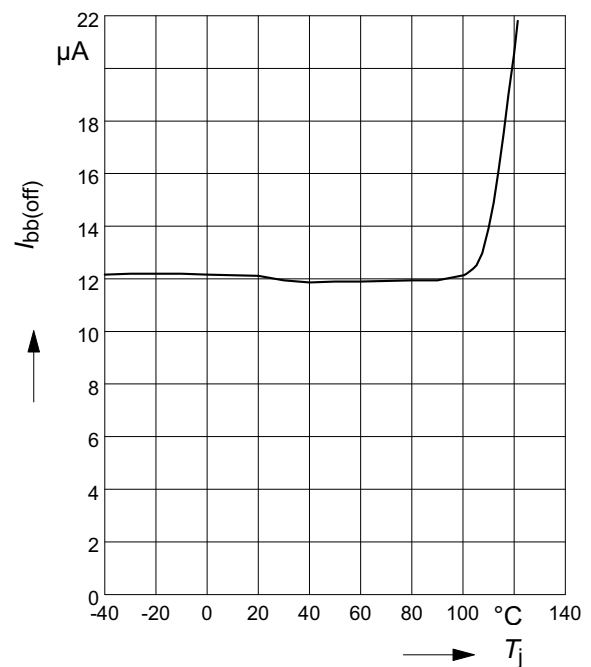

Maximum allowable inductive switch-off energy, single pulse

$E_{AS} = f(I_L); T_{jstart} = 125^\circ\text{C}$

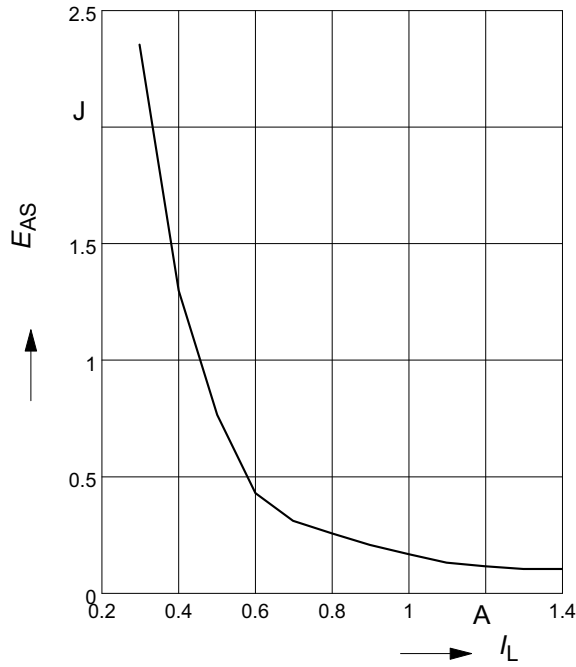

Typ. leakage current

$I_{L(off)} = f(T_j); V_{bb} = 32\text{V}; V_{IN} \leq 1,2\text{ V}$

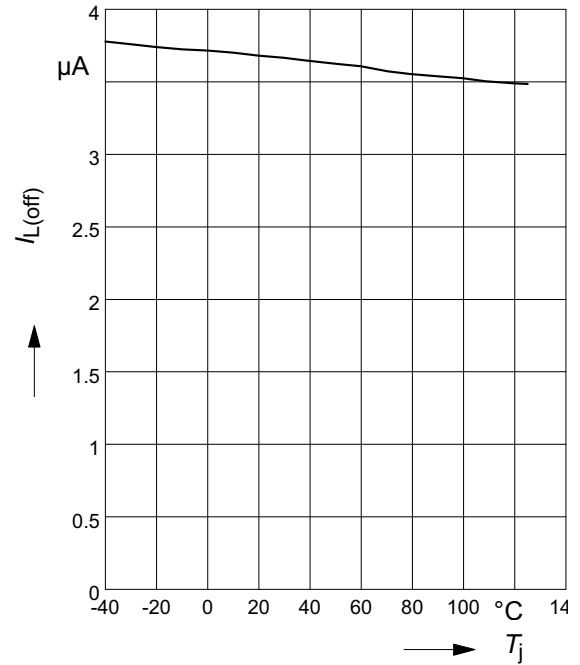

Typ. input delay time at switch on V_{bb}

$t_d(V_{bbon}) = f(V_{bb})$

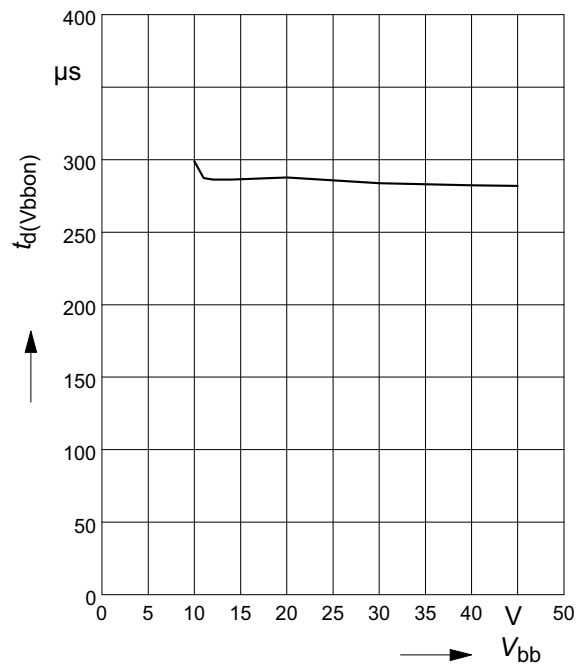

Timing diagrams

Figure 1a: V_{bb} turn on:

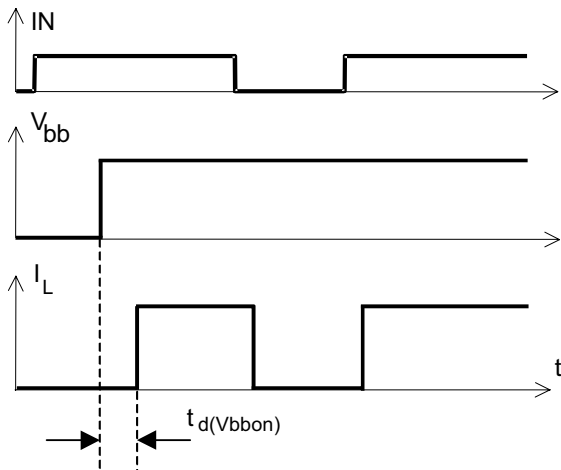

Figure 2b: Switching a lamp

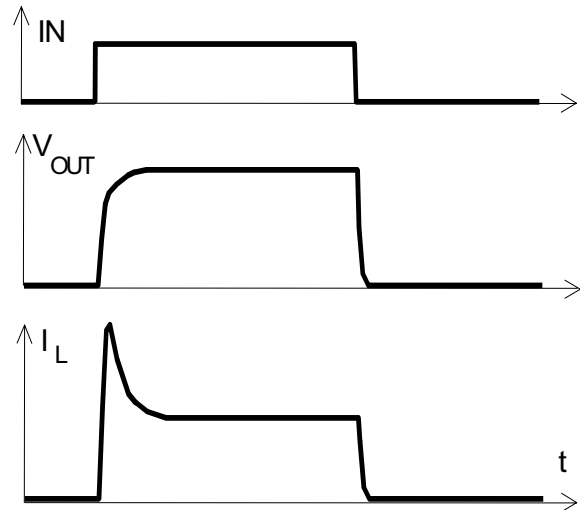

Figure 2a: Switching a resistive load, turn-on/off time and slew rate definition

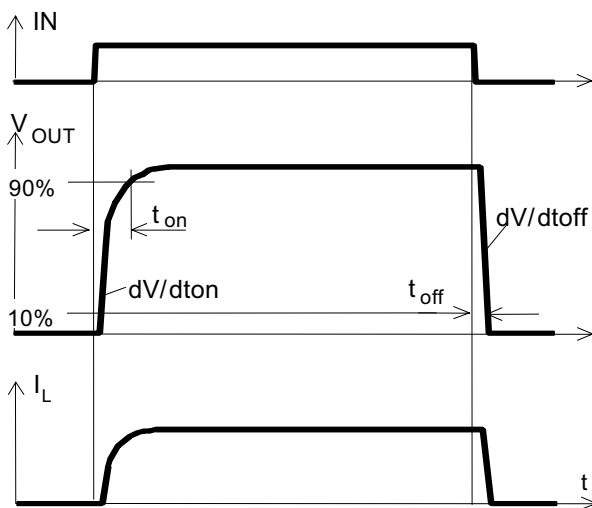
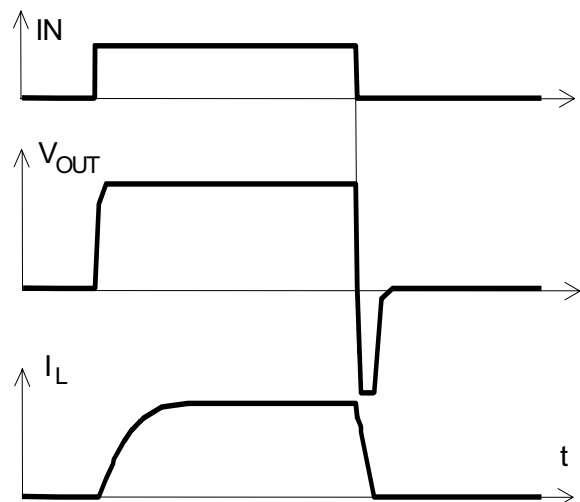

Figure 2c: Switching an inductive load



Package Outlines

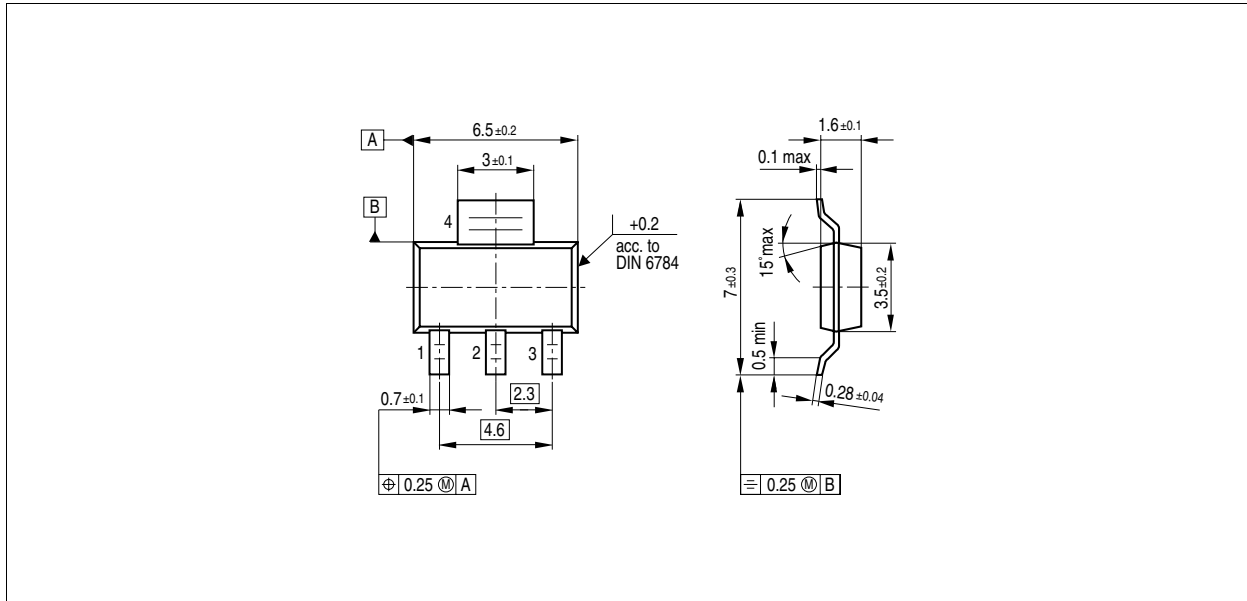

Figure 1 PG-SOT-223 (Plastic Dual Small Outline Package) (RoHS-compliant)

To meet the world-wide customer requirements for environmentally friendly products and to be compliant with government regulations the device is available as a green product. Green products are RoHS-Compliant (i.e. Pb-free finish on leads and suitable for Pb-free soldering according to IPC/JEDEC J-STD-020).

Please specify the package needed (e.g. green package) when placing an order

Revision History

Version	Date	Changes
V1.1	2007-05-29	Creation of the green datasheet. First page : Adding the green logo and the AEC qualified Adding the bullet AEC qualified and the RoHS compliant features Package page Modification of the package to be green.

Edition 2007-05-29

**Published by
Infineon Technologies AG
81726 Munich, Germany**

**© Infineon Technologies AG 5/29/07.
All Rights Reserved.**

Legal Disclaimer

The information given in this document shall in no event be regarded as a guarantee of conditions or characteristics ("Beschaffheitsgarantie"). With respect to any examples or hints given herein, any typical values stated herein and/or any information regarding the application of the device, Infineon Technologies hereby disclaims any and all warranties and liabilities of any kind, including without limitation warranties of non-infringement of intellectual property rights of any third party.

Information

For further information on technology, delivery terms and conditions and prices please contact your nearest Infineon Technologies Office (www.infineon.com).

Warnings

Due to technical requirements components may contain dangerous substances. For information on the types in question please contact your nearest Infineon Technologies Office.

Infineon Technologies Components may only be used in life-support devices or systems with the express written approval of Infineon Technologies, if a failure of such components can reasonably be expected to cause the failure of that life-support device or system, or to affect the safety or effectiveness of that device or system. Life support devices or systems are intended to be implanted in the human body, or to support and/or maintain and sustain and/or protect human life. If they fail, it is reasonable to assume that the health of the user or other persons may be endangered.