

FS7M0680, FS7M0880

Fairchild Power Switch (FPS™)

Features

- Pulse by Pulse Current Limit
- Over load protection (OLP) - Latch
- Over voltage protection (OVP) - Latch
- Internal Thermal Shutdown (TSD) - Latch
- Under Voltage Lock Out (UVLO) with hysteresis
- Internal High Voltage SenseFET (800V rated)
- User defined Soft Start
- Precision Fixed Operating Frequency (66kHz)

Application

- PC power supply
- PDP

Description

The Fairchild Power Switch FS7M-series is an integrated Pulse Width Modulator (PWM) and Sense FET specifically designed for high performance offline Switch Mode Power Supplies (SMPS) with minimal external components. This device is an integrated high voltage power switching regulator which combine an avalanche rugged Sense FET with a current mode PWM control block. The PWM controller includes integrated fixed frequency oscillator, under voltage lockout, leading edge blanking (LEB), optimized gate driver, soft start, temperature compensated precise current sources for a loop compensation and self protection circuitry. Compared with discrete MOSFET and PWM controller solution, it can reduce total cost, component count, size and weight simultaneously increasing efficiency, productivity, and system reliability. This device is a basic platform well suited for cost effective designs of flyback and forward converters.

Table 1. Maximum Output Power

OUTPUT POWER TABLE		
PRODUCT	230VAC $\pm 15\%$ ⁽²⁾	85-265VAC
	Open Frame ⁽¹⁾	Open Frame ⁽¹⁾
FS7M0680	80W (Flyback) 150W (Forward) 180W (Forward) ⁽³⁾	65W (Flyback)
FS7M0880	110W (Flyback) 200W (Forward) 250W (Forward) ⁽³⁾	85W (Flyback)

Notes: 1. Maximum practical continuous power in an open frame design at 50°C ambient. 2. 230 VAC or 100/115 VAC with doubler. 3. When the cooling fan is used.

Typical Circuit

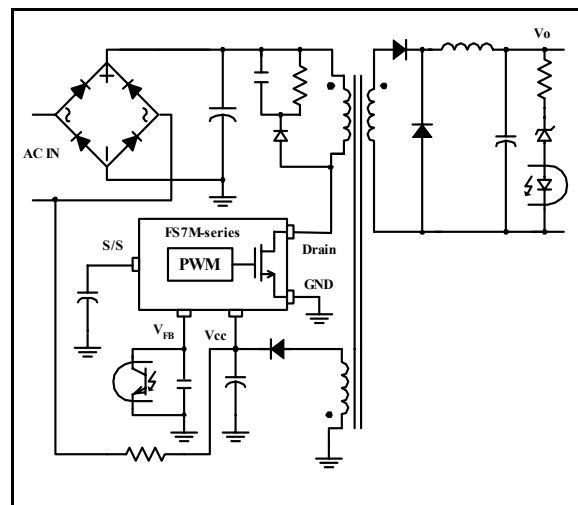

Figure 1. Typical Forward Application

Internal Block Diagram

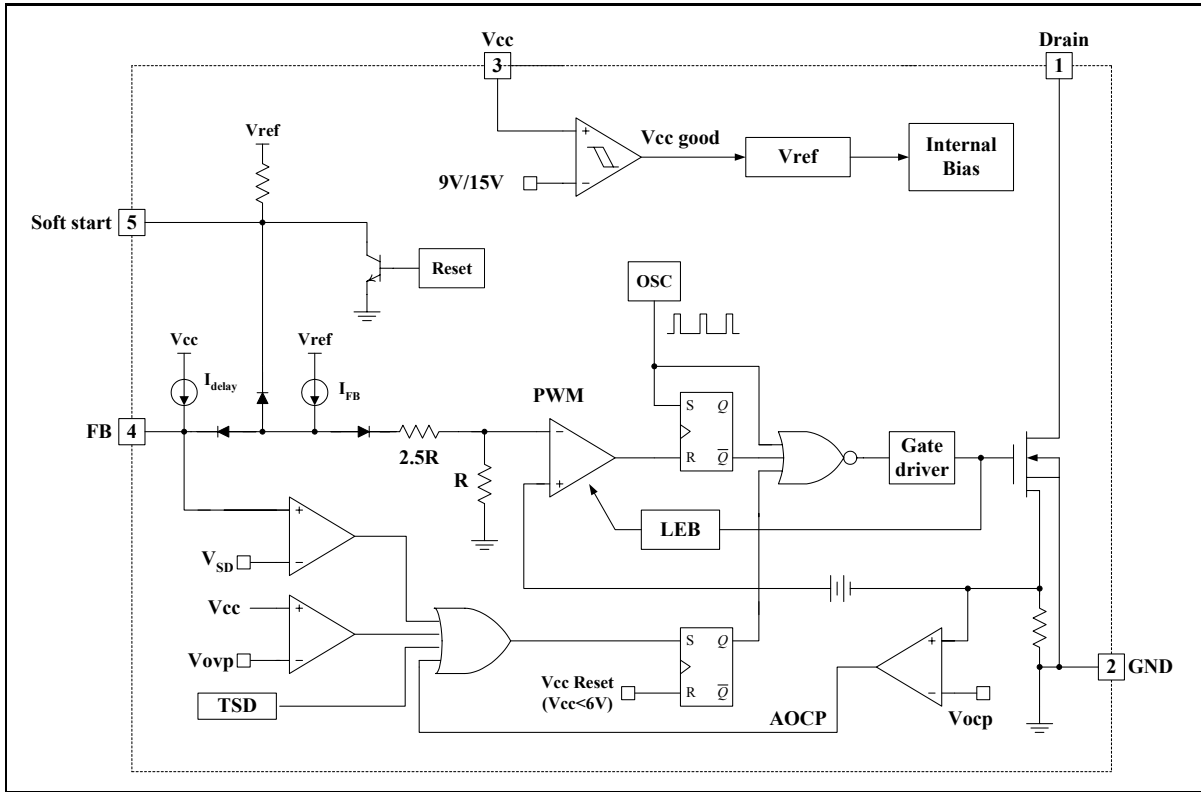

Figure 2. Functional Block Diagram of FS7M0680 and FS7M0880

Pin Definitions

Pin Number	Pin Name	Pin Function Description
1	Drain	High voltage power SenseFET drain connection.
2	GND	This pin is the control ground and the SenseFET source.
3	Vcc	This pin is the positive supply input. This pin provides internal operating current for both start-up and steady-state operation.
4	Vfb	This pin is internally connected to the inverting input of the PWM comparator. The collector of an opto-coupler is typically tied to this pin. For stable operation, a capacitor should be placed between this pin and GND. If the voltage of this pin reaches 7.5V, the over load protection triggers resulting in shutdown of the FPS.
5	Soft-start	This pin is for the soft start. Soft start time is programmed by a capacitor on this pin.

Pin Configuration

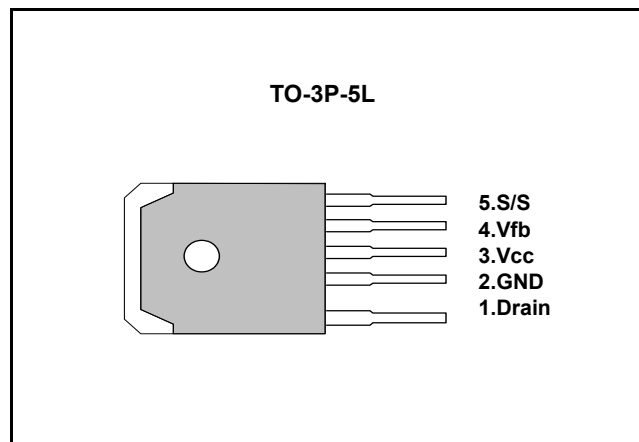

Figure 3. Pin Configuration (Top View)

Absolute Maximum Ratings

FS7M0680			
Parameter	Symbol	Value	Unit
Maximum Drain Voltage ⁽¹⁾	V _{D,MAX}	800	V
Drain-Gate Voltage (R _{GS} =1MΩ)	V _{DGR}	800	V
Gate-Source (GND) Voltage	V _{GS}	±30	V
Drain Current Pulsed ⁽²⁾	I _{DM}	24.0	ADC
Single Pulsed Avalanche Energy ⁽³⁾	E _{AS}	455	mJ
Avalanche Current ⁽⁴⁾	I _{AS}	20	A
Continuous Drain Current (T _C =25°C)	I _D	6.0	ADC
Continuous Drain Current (T _C =100°C)	I _D	3.8	ADC
Maximum Supply Voltage	V _{CC,MAX}	30	V
Input Voltage Range	V _{FB}	-0.3 to V _{SD}	V
Total Power Dissipation	P _D	150	W
	Derating	1.21	W/°C
Operating Ambient Temperature	T _A	-25 to +85	°C
Storage Temperature	T _{STG}	-55 to +150	°C

FS7M0880			
Parameter	Symbol	Value	Unit
Maximum Drain Voltage ⁽¹⁾	V _{D,MAX}	800	V
Drain-Gate Voltage (R _{GS} =1MΩ)	V _{DGR}	800	V
Gate-Source (GND) Voltage	V _{GS}	±30	V
Drain Current Pulsed ⁽²⁾	I _{DM}	32.0	ADC
Single Pulsed Avalanche Energy ⁽³⁾	E _{AS}	810	mJ
Avalanche Current ⁽⁴⁾	I _{AS}	15	A
Continuous Drain Current (T _C =25°C)	I _D	8.0	ADC
Continuous Drain Current (T _C =100°C)	I _D	5.6	ADC
Maximum Supply Voltage	V _{CC,MAX}	30	V
Input Voltage Range	V _{FB}	-0.3 to V _{SD}	V
Total Power Dissipation	P _D	190	W
	Derating	1.54	W/°C
Operating Ambient Temperature	T _A	-25 to +85	°C
Storage Temperature	T _{STG}	-55 to +150	°C

Note:

1. T_j = 25°C to 150°C
2. Repetitive rating: Pulse width limited by maximum junction temperature
3. L = 24mH, V_{DD} = 50V, R_G = 25Ω, starting T_j = 25°C
4. L = 13μH, starting T_j = 25°C

Electrical Characteristics (SenseFET Part)

(Ta=25°C unless otherwise specified)

FS7M0680						
Parameter	Symbol	Condition	Min.	Typ.	Max.	Unit
Drain-Source Breakdown Voltage	BVDSS	VGS=0V, ID=50μA	800	-	-	V
Zero Gate Voltage Drain Current	IDSS	VDS=Max., Rating, VGS=0V	-	-	50	μA
		VDS=0.8Max., Rating, VGS=0V, TC=125°C	-	-	200	μA
Static Drain-Source On Resistance ^(note1)	RDS(ON)	VGS=10V, ID=5.0A	-	1.6	2.0	Ω
Input Capacitance	Ciss	VGS=0V, VDS=25V, f=1MHz	-	1600	-	pF
Output Capacitance	Coss		-	140	-	
Reverse Transfer Capacitance	Crss		-	42	-	
Turn On Delay Time	td(on)	VDD=0.5BVDSS, ID=8.0A (MOSFET switching time are essentially independent of operating temperature)	-	60	-	nS
Rise Time	tr		-	150	-	
Turn Off Delay Time	td(off)		-	300	-	
Fall Time	tf		-	130	-	
Total Gate Charge (Gate-Source+Gate-Drain)	Qg	VGS=10V, ID=8.0A, VDS=0.5BVDSS (MOSFET switching time are essentially independent of operating temperature)	-	70	-	nC
Gate-Source Charge	Qgs		-	16	-	
Gate-Drain (Miller) Charge	Qgd		-	27	-	

FS7M0880						
Parameter	Symbol	Condition	Min.	Typ.	Max.	Unit
Drain-Source Breakdown Voltage	BVDSS	VGS=0V, ID=50μA	800	-	-	V
Zero Gate Voltage Drain Current	IDSS	VDS=Max., Rating, VGS=0V	-	-	50	μA
		VDS=0.8Max., Rating, VGS=0V, TC=125°C	-	-	200	μA
Static Drain-Source On Resistance ^(note1)	RDS(ON)	VGS=10V, ID=5.0A	-	1.2	1.5	Ω
Input Capacitance	Ciss	VGS=0V, VDS=25V, f=1MHz	-	2460	-	pF
Output Capacitance	Coss		-	210	-	
Reverse Transfer Capacitance	Crss		-	64	-	
Turn On Delay Time	td(on)	VDD=0.5BVDSS, ID=8.0A (MOSFET switching time are essentially independent of operating temperature)	-	-	90	nS
Rise Time	tr		-	95	200	
Turn Off Delay Time	td(off)		-	150	450	
Fall Time	tf		-	60	150	
Total Gate Charge (Gate-Source+Gate-Drain)	Qg	VGS=10V, ID=8.0A, VDS=0.5BVDSS (MOSFET switching time are essentially independent of operating temperature)	-	-	150	nC
Gate-Source Charge	Qgs		-	20	-	
Gate-Drain (Miller) Charge	Qgd		-	70	-	

Note:

1. Pulse test: Pulse width ≤ 300μS, duty cycle ≤ 2%

Electrical Characteristics (Continued)

(Ta=25°C unless otherwise specified)

Parameter	Symbol	Condition	Min.	Typ.	Max.	Unit
UVLO SECTION						
Start Threshold Voltage	VSTART	-	14	15	16	V
Stop Threshold Voltage	VSTOP	After turn on	8	9	10	V
OSCILLATOR SECTION						
Initial Frequency	FOSC	-	60	66	72	kHz
Frequency Change With Temperature ⁽²⁾	$\Delta F/\Delta T$	-25°C ≤ Ta ≤ +85°C	-	±5	±10	%
Maximum Duty Cycle	Dmax	-	45	50	55	%
FEEDBACK SECTION						
Feedback Source Current	IFB	Ta=25°C, 0V ≤ Vfb ≤ 3V	0.7	0.9	1.1	mA
Shutdown Delay Current	Idelay	Ta=25°C, 5V ≤ Vfb ≤ VSD	4.0	5.0	6.0	μA
SOFT START SECTION						
Soft Start Voltage	VSS	VFB = 2V	4.7	5.0	5.3	V
Soft Start Current	ISS	Sync & S/S=GND	0.8	1.0	1.2	mA
CURRENT LIMIT (SELT-PROTECTION)SECTION						
FS7M0680	I _{OVER}	Max. inductor current	3.52	4.00	4.48	A
FS7M0880	I _{OVER}	Max. inductor current	4.40	5.00	5.60	A
PROTECTION SECTION						
Thermal Shutdown Temperature (Tj) ⁽¹⁾	TSD	-	140			°C
Over Voltage Protection Voltage	VOVP	-	25	28	31	V
Over Current Protection Voltage	VOCP	-	1.05	1.10	1.15	V
TOTAL DEVICE SECTION						
Start Up Current	ISTART	VCC=14V	-	40	80	uA
Operating Supply Current (Control Part Only)	IOP	Ta=25°C	-	8	12	mA
	Iop(lat)	After latch, Vcc=Vstop-0.1V	150	250	350	uA
Shutdown Feedback Voltage	VSD	-	6.9	7.5	8.1	V

Note:

1. These parameters, although guaranteed, are not 100% tested in production
2. These parameters, although guaranteed, are tested in EDS (wafer test) process

Electrical characteristics

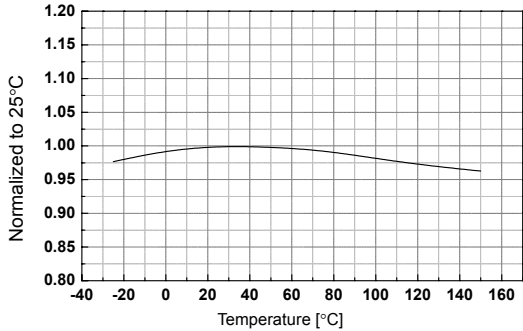

Operating Supply Current vs. Temp.

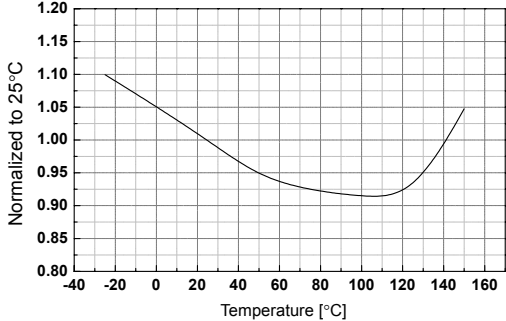

Start up Current vs. Temp.

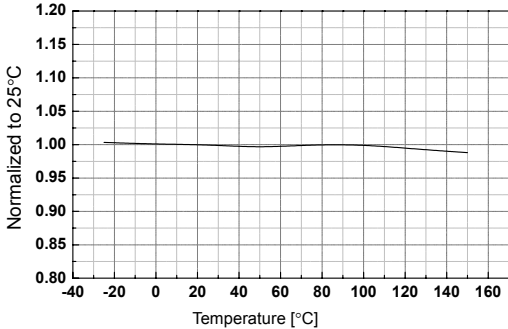

Vcc Start Threshold Voltage vs. Temp.

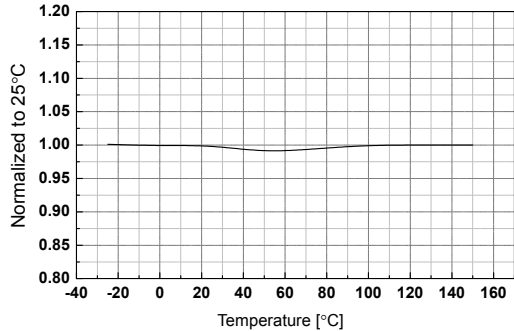

Vcc Stop Threshold Voltage vs. Temp.

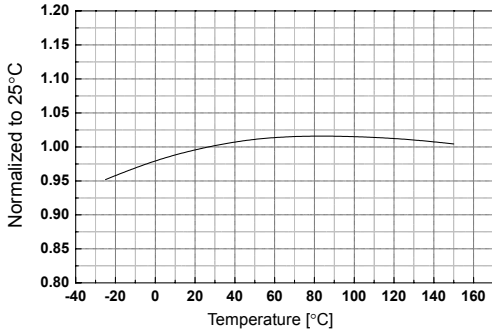

Operating Frequency vs. Temp.

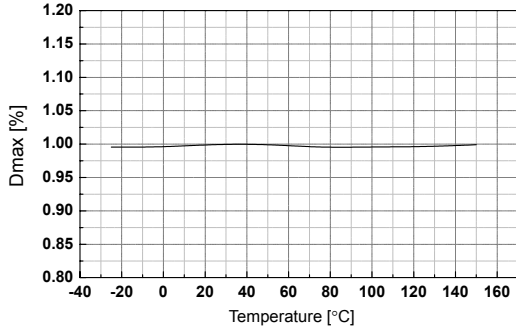

Maximum Duty Cycle vs. Temp.

Electrical characteristics

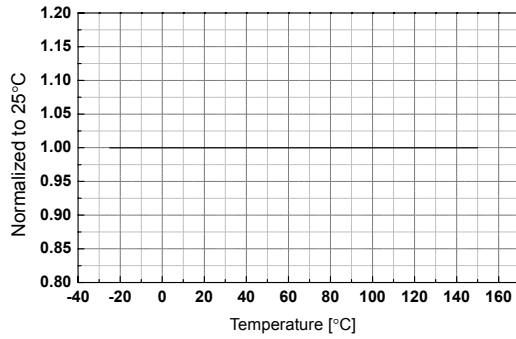

Minimum Duty Cycle vs. Temp.

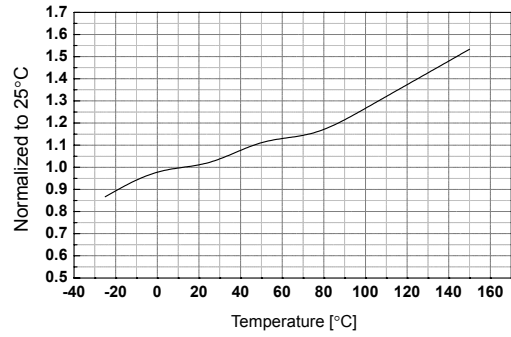

Feedback Offset Voltage vs. Temp.

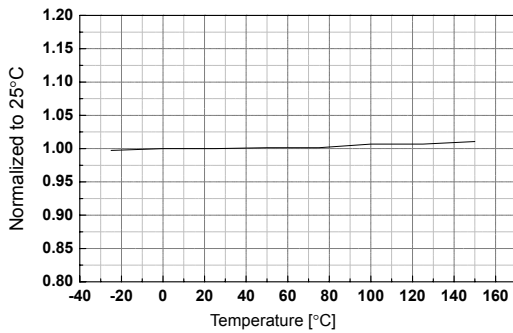

Shutdown Feedback Voltage vs. Temp.

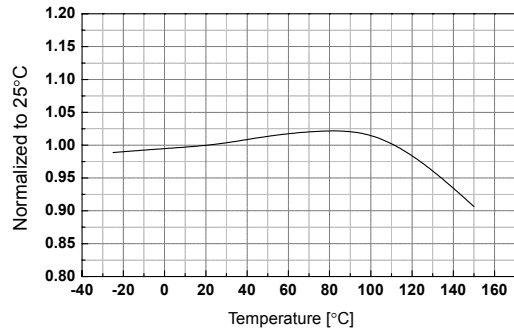

Shutdown Delay Current vs. Temp.

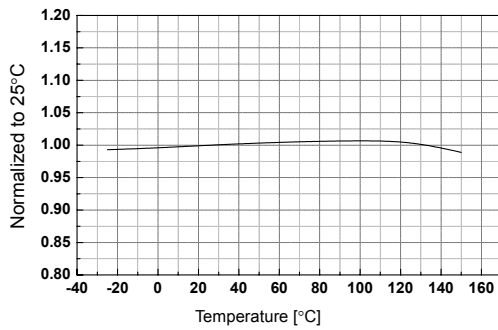

SoftStart Voltage vs. Temp.

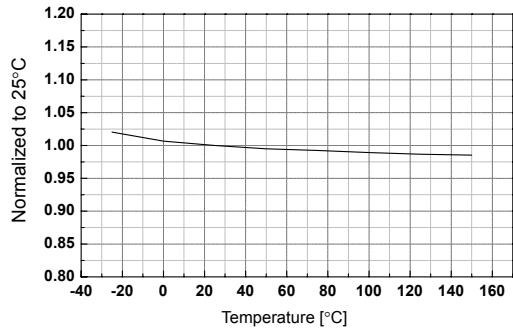

Over Voltage Protection vs. Temp.

Electrical characteristics

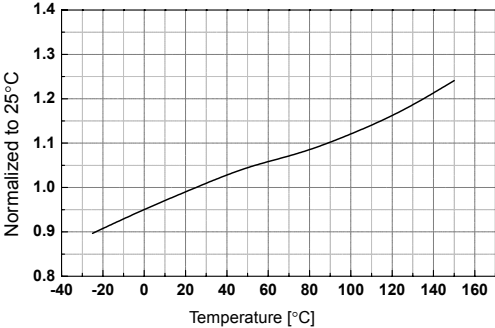

Feedback Current vs. Temp.

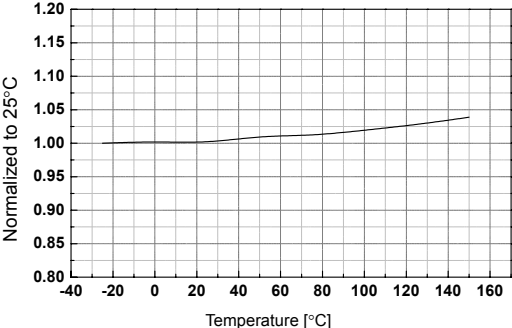

Pulse-by-pulse Current limit vs. Temp.

Functional Description

1. **Startup** : Figure 4 shows the typical startup circuit and transformer auxiliary winding for FS7M-series. Because all the protections are implemented as latch mode, AC startup is typically used to provide a fast reset as shown in Figure 4. Before FPS begins switching operation, only startup current (typically 40uA) is consumed and the current supplied from the AC line charges the external capacitor (C_a) that is connected to the Vcc pin. When Vcc reaches start voltage of 15V (V_{START}), FPS begins switching, and the current consumed by FPS increases to 8mA. Then, FPS continues its normal switching operation and the power required for this device is supplied from the transformer auxiliary winding, unless Vcc drops below the stop voltage of 9V (V_{STOP}). To guarantee the stable operation of the control IC, Vcc has under voltage lockout (UVLO) with 6V hysteresis. Figure 5 shows the relation between the FPS operating supply current and the supply voltage (Vcc).

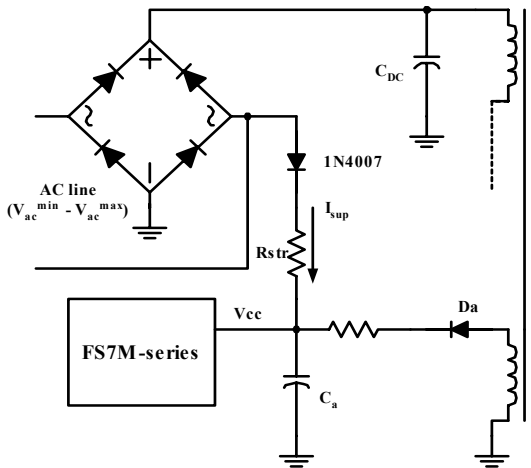

Figure 4. Startup circuit

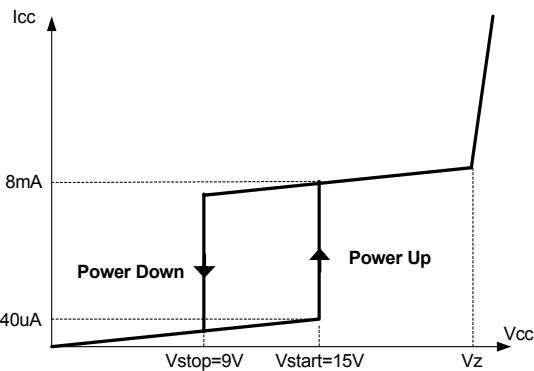

Figure 5. Relation between operating supply current and Vcc voltage

The minimum average of the current supplied from the AC is given by

$$I_{sup}^{avg} = \left(\frac{\sqrt{2} \cdot V_{ac}^{min}}{\pi} - \frac{V_{start}}{2} \right) \cdot \frac{1}{R_{str}}$$

where V_{ac}^{min} is the minimum input voltage, V_{start} is the Vcc start voltage (15V) and R_{str} is the startup resistor. The startup resistor should be chosen so that I_{sup}^{avg} is larger than the maximum startup current (80uA).

Once the resistor value is determined, the maximum loss in the startup resistor is obtained as

$$Loss = \frac{1}{R_{str}} \cdot \left(\frac{(V_{ac}^{max})^2}{2} + V_{start}^2 - \frac{2 \cdot \sqrt{2} \cdot V_{start} \cdot V_{ac}^{max}}{\pi} \right)$$

where V_{ac}^{max} is the maximum input voltage. The startup resistor should have proper rated dissipation wattage.

2. **Feedback Control** : FS7M-series employs current mode control, as shown in Figure 6. An opto-coupler (such as the H11A817A) and shunt regulator (such as the KA431) are typically used to implement the feedback network. Comparing the feedback voltage with the voltage across the Rsense resistor plus an offset voltage makes it possible to control the switching duty cycle. When the reference pin voltage of the KA431 exceeds the internal reference voltage of 2.5V, the H11A817A LED current increases, thus pulling down the feedback voltage and reducing the duty cycle. This event typically happens when the input voltage is increased or the output load is decreased.

2.1 **Pulse-by-pulse current limit**: Because current mode control is employed, the peak current through the Sense FET is limited by the inverting input of PWM comparator (V_{fb}^*) as shown in Figure 6. The feedback current (I_{FB}) and internal resistors are designed so that the maximum cathode voltage of diode D2 is about 2.8V, which occurs when all I_{FB} flows through the internal resistors. Since D1 is blocked when the feedback voltage (Vfb) exceeds 2.8V, the maximum voltage of the cathode of D2 is clamped at this voltage, thus clamping V_{fb}^* . Therefore, the peak value of the current through the Sense FET is limited.

2.2 **Leading edge blanking (LEB)** : At the instant the internal Sense FET is turned on, there usually exists a high current spike through the Sense FET, caused by external resonant capacitor across the MOSFET and secondary-side rectifier reverse recovery. Excessive voltage across the Rsense resistor would lead to incorrect feedback operation in the current mode PWM control. To counter this effect, the FPS employs a leading edge blanking (LEB) circuit. This circuit inhibits the PWM comparator for a short time (TLEB) after the Sense FET is turned on.

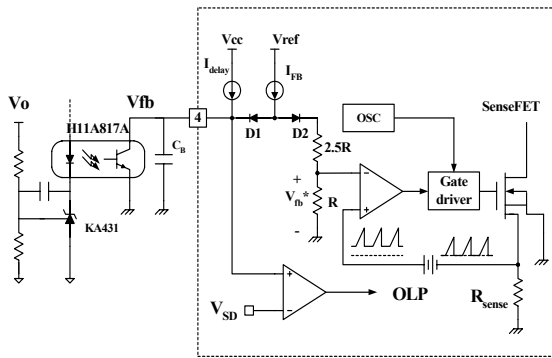

Figure 6. Pulse width modulation (PWM) circuit

3. Protection Circuit : The FS7M-series has several self protective functions such as over load protection (OLP), abnormal over current protection (AOCP), over voltage protection (OVP) and thermal shutdown (TSD). All the protections are latch mode protection. Because these protection circuits are fully integrated into the IC without external components, the reliability can be improved without increasing cost.

Once protection triggers, switching is terminated and Vcc continues charging and discharging between 9V and 15V until the AC power line is un-plugged. The latch is reset only when Vcc is fully discharged by un-plugging the AC power line.

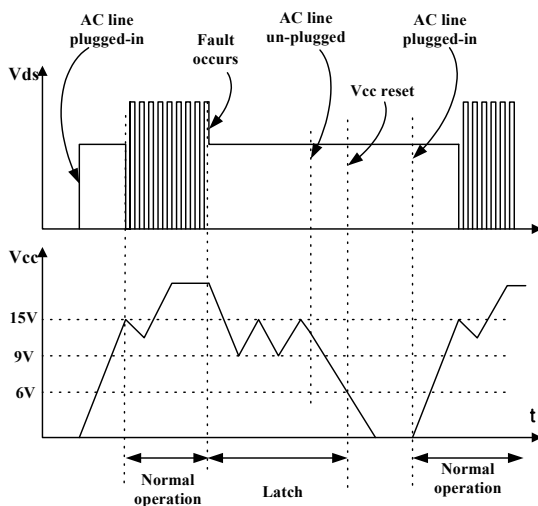

Figure 7. Auto restart mode protection

3.1 Over Load Protection (OLP) : Overload is defined as the load current exceeding its normal level due to an unexpected abnormal event. In this situation, the protection circuit should trigger in order to protect the SMPS. However, even when the SMPS is in the normal operation, the over load protection circuit can be triggered during the load transition. In order to avoid this undesired operation, the over load protection circuit is designed to trigger after a specified time to determine whether it is a transient situation or an overload situation. Because of the pulse-by-pulse current limit capability, the maximum peak current through the Sense FET is limited, and therefore the maximum input power is restricted with a given input voltage. If the output consumes more than this maximum power, the output voltage (Vo) decreases below the set voltage. This reduces the current through the opto-coupler LED, which also reduces the opto-coupler transistor current, thus increasing the feedback voltage (Vfb). If Vfb exceeds 2.8V, D1 is blocked and the 5uA current source starts to charge CB slowly up to Vcc. In this condition, Vfb continues increasing until it reaches 7.5V, when the switching operation is terminated as shown in Figure 8. The delay time for shutdown is the time required to charge CB from 2.8V to 7.5V with 5uA. In general, a 20 ~ 50 ms delay time is typical for most applications. This protection is implemented in auto restart mode.

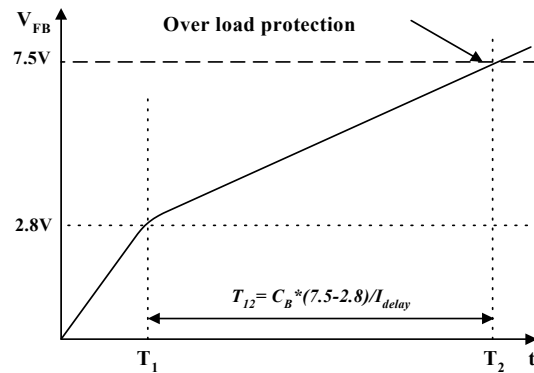

Figure 8. Over load protection

3.2 Abnormal Over Current Protection (AOCP) : When the secondary rectifier diodes or the transformer pins are shorted, a steep current with extremely high di/dt can flow through the SenseFET during the LEB time. Even though the FS7M-series has OLP (Over Load Protection), it is not enough to protect the FPS in that abnormal case, since sever current stress will be imposed on the SenseFET until OLP triggers. The FS7M-series has an internal AOCP (Abnormal Over Current Protection) circuit as shown in Figure 9. When the gate turn-on signal is applied to the power Sense FET, the AOCP block is enabled and monitors the current through the sensing resistor. The voltage across the resistor is then

compared with a preset AOCP level. If the sensing resistor voltage is greater than the AOCP level, the set signal is applied to the latch, resulting in the shutdown of SMPS. This protection is implemented in latch mode.

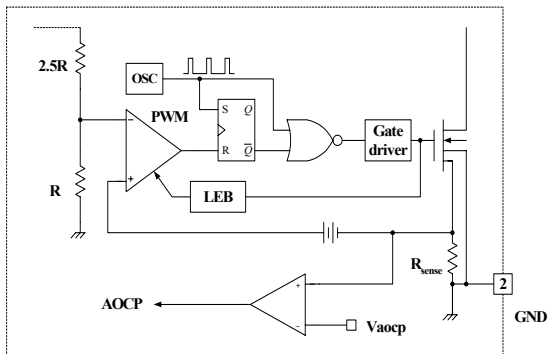

Figure 9. AOCP block

3.3 Over voltage Protection (OVP) : If the secondary side feedback circuit were to malfunction or a solder defect caused an open in the feedback path, the current through the opto-coupler transistor becomes almost zero. Then, V_{fb} climbs up in a similar manner to the over load situation, forcing the preset maximum current to be supplied to the SMPS until the over load protection is activated. Because more energy than required is provided to the output, the output voltage may exceed the rated voltage before the over load protection is activated, resulting in the breakdown of the devices in the secondary side. In order to prevent this situation, an over voltage protection (OVP) circuit is employed. In general, V_{cc} is proportional to the output voltage and the FPS uses V_{cc} instead of directly monitoring the output voltage. If V_{CC} exceeds 28V, an OVP circuit is activated resulting in the termination of the switching operation. In order to avoid undesired activation of OVP during normal operation, V_{cc} should be designed to be below OVP threshold.

3.4 Thermal Shutdown (TSD) : The SenseFET and the control IC are built in one package. This makes it easy for the control IC to detect the abnormal over temperature of the SenseFET. When the temperature exceeds approximately 150°C, the thermal shutdown triggers. This protection is implemented in latch mode.

4. Soft Start : The FS7M-series has a soft start circuit that increases PWM comparator inverting input voltage together with the SenseFET current slowly after it starts up. The soft start time can be programmed using a capacitor on the soft-start pin. The pulse width to the power switching device is progressively increased to establish the correct working conditions for transformers, inductors, and capacitors. It also helps to prevent transformer saturation and reduce the stress on the secondary diode during startup.

Typical application circuit I (7M0880 : Forward)

Application	Output power	Input voltage	Output voltage (Max current)
PC Power	250W (Cooling Fan)	Universal input with voltage doubler	5V (26A), 12V (10A)

1. Schematic

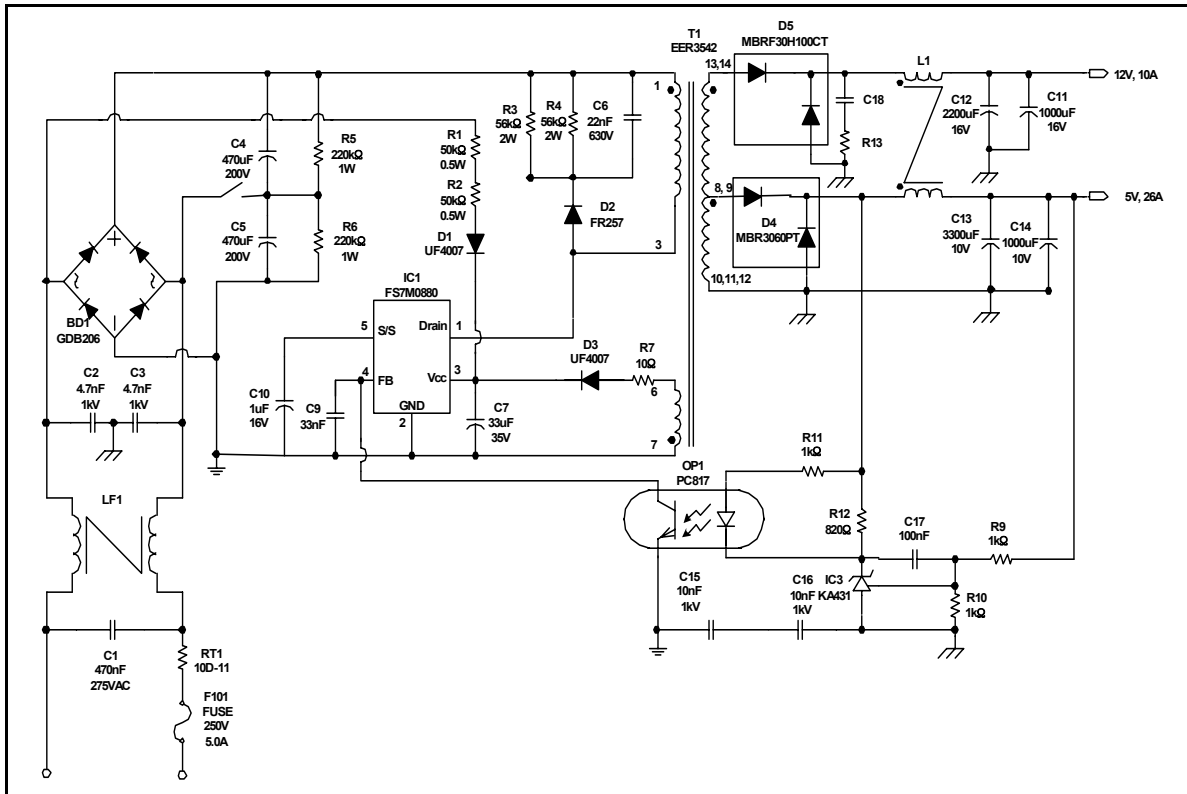

2. Transformer Specification (CORE : EER 3542 , BOBBIN : EER3542)

No.	PIN(S → F)	WIRE	TURNS	WINDING METHOD
NP/2	1 → 3	0.65 φ × 1	50T	SOLENOID WINDING
N+5V	8, 9 → 10, 11, 12	15mm × 0.15mm × 1	4T	COPPER FOIL WINDING
N+12V	13, 14 → 9	0.65φ × 3	5T	SOLENOID WINDING
NP/2	1 → 3	0.65 φ × 1	50T	SOLENOID WINDING
NVCC	7 → 6	0.6 φ × 1	6T	SOLENOID WINDING

Transformer Electrical Characteristics

	Pin	Specification	Remarks
Inductance	1 - 3	6mH ± 5%	@70kHz, 1V
Leakage Inductance	1 - 3	15uH Max	2 nd all short

3. Secondary Inductor(L1) Specification

Core : Power Core 27 φ 16 Grade

5V : 12T (1 φ × 2)

10V : 27T (1.2 φ × 1)

Typical application circuit II (7M0880 : Flyback)

Application	Output power	Input voltage	Output voltage (Max current)
Adaptor	108W	European Input	12V (9A)

1. Schematic

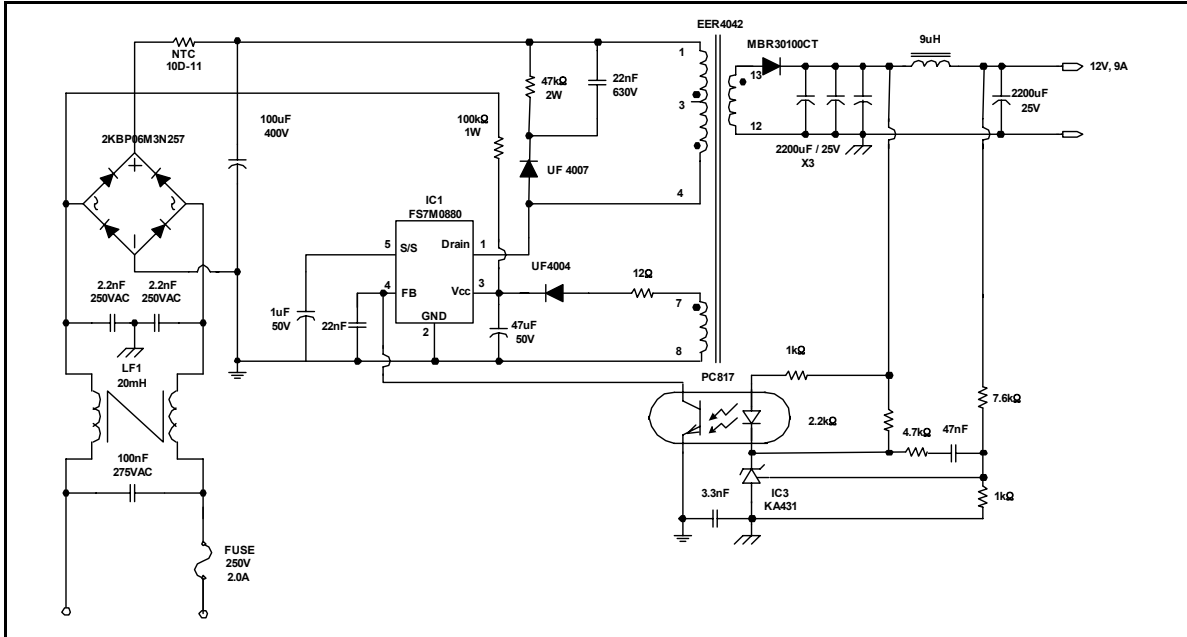

2. Transformer Specification

Winding Specification

No.	PIN(S → F)	WIRE	TURNS	WINDING METHOD
NP/2	1 → 3	0.4 φ × 1	42	SOLENOID WINDING
INSULATION : POLYESTER TAPE t = 0.050mm, 1Layer				
N+12V	12 → 13	14mm × 0.15mm × 1	8	COPPER WINDING
INSULATION : POLYESTER TAPE t = 0.050mm, 3Layer				
NB	8 → 7	0.3 φ × 1	9	SOLENOID WINDING
INSULATION : POLYESTER TAPE t = 0.050mm, 1Layer				
NP/2	3 → 4	0.4 φ × 1	42	SOLENOID WINDING
OUTER INSULATION : POLYESTER TAPE t = 0.050mm, 3Layer				

Electrical Characteristic

CLOSURE	PIN	SPEC.	REMARKS
INDUCTANCE	1 - 4	700uH ±10%	1kHz, 1V
LEAKAGE L	1 - 4	10uH MAX.	2nd ALL SHORT

Core & Bobbin

CORE : EER 4042 , BOBBIN : EER4042

Package Dimensions

TO-3P-5L

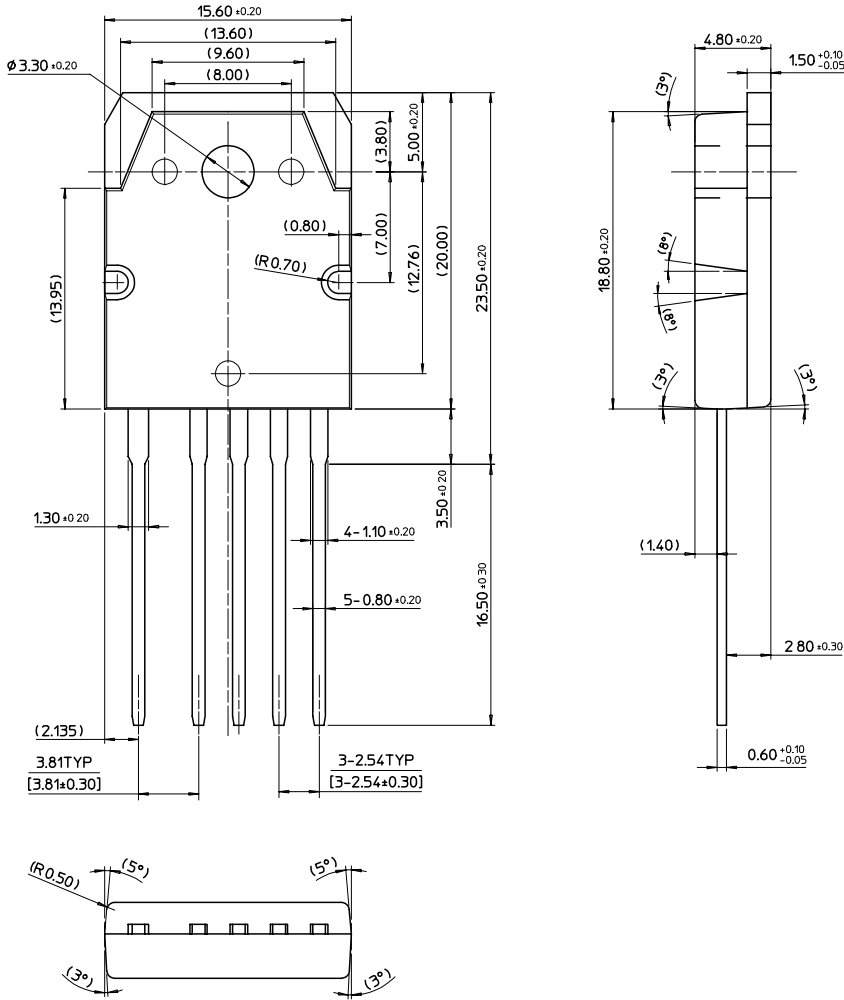

Ordering Information

Product Number	Package	Rating	Fosc
FS7M0680TU	TO-3P-5L	800V, 6A	66kHz
FS7M0680YDTU	TO-3P-5L(Forming)		
FS7M0880TU	TO-3P-5L	800V, 8A	66kHz
FS7M0880YDTU	TO-3P-5L(Forming)		

TU : Non Forming Type

YDTU : Forming type

DISCLAIMER

FAIRCHILD SEMICONDUCTOR RESERVES THE RIGHT TO MAKE CHANGES WITHOUT FURTHER NOTICE TO ANY PRODUCTS HEREIN TO IMPROVE RELIABILITY, FUNCTION OR DESIGN. FAIRCHILD DOES NOT ASSUME ANY LIABILITY ARISING OUT OF THE APPLICATION OR USE OF ANY PRODUCT OR CIRCUIT DESCRIBED HEREIN; NEITHER DOES IT CONVEY ANY LICENSE UNDER ITS PATENT RIGHTS, NOR THE RIGHTS OF OTHERS.

LIFE SUPPORT POLICY

FAIRCHILD'S PRODUCTS ARE NOT AUTHORIZED FOR USE AS CRITICAL COMPONENTS IN LIFE SUPPORT DEVICES OR SYSTEMS WITHOUT THE EXPRESS WRITTEN APPROVAL OF THE PRESIDENT OF FAIRCHILD SEMICONDUCTOR CORPORATION. As used herein:

1. Life support devices or systems are devices or systems which, (a) are intended for surgical implant into the body, or (b) support or sustain life, and (c) whose failure to perform when properly used in accordance with instructions for use provided in the labeling, can be reasonably expected to result in a significant injury of the user.
2. A critical component in any component of a life support device or system whose failure to perform can be reasonably expected to cause the failure of the life support device or system, or to affect its safety or effectiveness.