

HV758 $\pm 90V$ 2.2A Ultrasound Pulser Demoboard

Introduction

The HV758 is a monolithic 4-channel, high-speed, high voltage, ultrasound transmitter pulser. This integrated, high performance circuit is in a single, 8x8mm, 64-Ball FCBGA package.

The HV758 can deliver up to a $\pm 2.2A$ source and sink current to a capacitive transducer. It is designed for medical ultrasound imaging and ultrasound NDT applications. It can also be used as a high voltage driver for other piezoelectric or capacitive MEMS transducers, or for ATE systems and pulse signal generators as a signal source.

HV758's circuitry consists of controller logic circuits, level translators, gate driving buffers and a high current and high voltage MOSFET output stage. The output stages of each channel are designed to provide peak output currents over $\pm 2.5A$ for pulsing, when $MC0 = 1$ and $MC1 = 1$, with up to $\pm 90V$ swings. When in mode 1, all the output stages drop the peak current to $\pm 580mA$ for low-voltage CW mode operation to save power. Two floating 9.0VDC power supplies referenced to V_{PP} and V_{NN} supply the P- and N-type power FET gate drivers. The upper limit frequency of the pulser waveform is 20MHz depending on the load capacitance. One HV758 can also be used as four damping circuits to generate fast return-to-zero waveforms by working with another HV758 as four pulsing circuits. It also has built-in, under-voltage and over-temperature protection functions.

Designing a Pulser with HV758

This demoboard data sheet describes how to use the HV758DB1 to generate the basic high voltage pulse waveform as an ultrasound transmitting pulser.

The HV758 circuit uses the DC coupling method in all level translators. There are no external coupling capacitors needed. The V_{PP} and V_{NN} rail voltages can be changed rather quickly, compared to a high voltage capacitor gate-coupled driving pulser. This direct coupling topology of the gate drivers not only saves two high voltage capacitors per channel, but also makes the PCB layout easier.

The input stage of the HV758 has high-speed level translators that are able to operate with logic signals of 1.2 to 5.0V and are optimized at 2.5 to 3.3V. In this demoboard, the control logic signals are connected to a high-speed ribbon cable connector. The control signal logic-high voltage should be the same as the V_{CC} voltage of the demoboard, and the logic-low should be referenced to GND.

The HV758DB1 output waveforms can be displayed using an oscilloscope directly by connecting the scope probe to the test point TX1 to 4 and GND. The soldering jumper can select whether or not to connect the on-board equivalent-load, a 330pF, 200V capacitor, parallel with a 2.5k Ω , 1W resistor. Also, a coaxial cable can be used to connect the user's transducer to easily drive and evaluate the HV758 transmitter pulser.

Typical Application Circuit

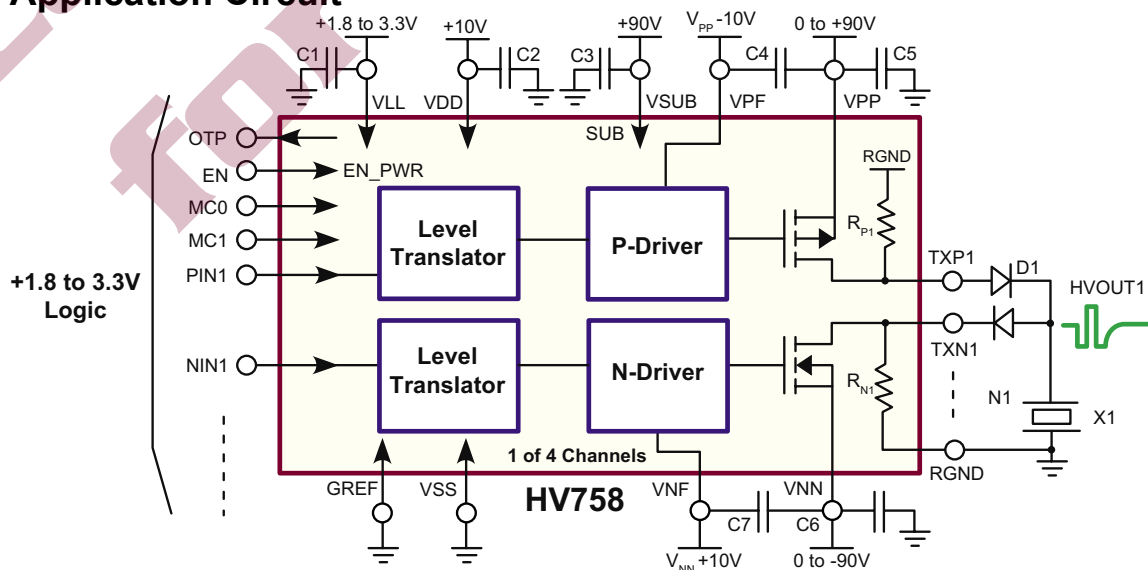

The PCB Layout Techniques

The large thermal pad at the bottom of the HV758 package is connected to the V_{SUB} pins to ensure that it always has the highest potential of the chip, in any condition. V_{SUB} is the connection of the IC's substrate. PCB designers need to pay attention to the connecting traces as the output TXP1 to 4, TXN1 to 4 high-voltage and high-speed traces. In particular, low capacitance to the ground plane and more trace spacing need to be applied in this situation.

High-speed PCB trace design practices that are compatible with about 50 - 100MHz operating speeds are used for the demoboard PCB layout. The internal circuitry of the HV758 can operate at quite a high frequency, with the primary speed limitation being load capacitance. Because of this high speed and the high transient currents that result when driving capacitive loads, the supply voltage bypass capacitors and the driver to the FET's gate-coupling capacitors should be as close to the pins as possible. The V_{SS} pin pads should have low inductance feed-through connections that are connected directly to a solid ground plane. The V_{DD} , V_{PP} , V_{PF} , V_{NF} and V_{NN} supplies can draw fast transient currents of up to $\pm 2.0A$, so they should be provided with a low-impedance bypass capacitor at the chip's pins. A ceramic capacitor of up to 0.22 - 1.0 μF may be used. Minimize the trace length to the ground plane, and insert a ferrite bead in the power supply lead to the capacitor to prevent resonance in the power supply lines. For applications that are sensitive to jitter and noise and using multiple HV758 ICs, insert another ferrite bead between V_{DD} and decouple each chip supply separately.

To reduce inductance, pay particular attention to minimizing trace lengths and using sufficient trace width. Surface mount components are highly recommended. Since the output impedance of HV758's high voltage power stages is very low, in some cases it may be desirable to add a small value resistor in series with the output TXP1 to 4 and TXN1 to 4 to obtain better waveform integrity at the load terminals. This will, of course, reduce the output voltage slew rate at the terminals of a capacitive load. Be aware of the parasitic coupling from the outputs to the input signal terminals of HV758. This feedback may cause oscillations or spurious waveform shapes on the edges of signal transitions. Since the input operates with signals down to 1.2V, even small coupling voltages may cause problems. Use of a solid ground plane and good power and signal layout practices will prevent this problem. Also ensure that the circulating ground return current from a capacitive load cannot react with common inductance to create noise voltages in the input logic circuitry.

Testing the Integrated Pulser

The HV758 pulser demoboard should be powered up with multiple lab DC power supplies with current limiting functions. The following power supply voltages and current limits have been used in the testing: $V_{PP} = 0$ to +90V 5.0mA, $V_{NN} = 0$ to -90V 5.0mA, $V_{DD} = +10V$ 10mA, $(V_{PP} - V_{PF}) = +10V$ 10mA, $(V_{NF} - V_{NN}) = +10V$ 10mA. $V_{CC} = +3.3V$ 5.0mA for HV758 V_{LL} , not including the user's logic circuits. The power-up or down sequences of the voltage supply ensure that the HV758 chip substrate V_{SUB} is always at the highest potential of all the voltages supplied to the IC.

The $(V_{PP} - V_{PF})$ and $(V_{NF} - V_{NN})$ are the two floating power supplies. They are only 9.0V, but floating with V_{PP} and V_{NN} . The floating voltages can be trimmed within the range of +8.0 to +12V to adjust the rising and falling time of the output pulses for the best HD2. Do not exceed the maximum voltage of +12V. The V_{PP} and V_{NN} are the positive and negative high voltages. They can be varied from 0 to +/-90V maximum. Note when the $V_{PP} = V_{NN} = 0$, the V_{PF} and V_{NF} in respect to the ground voltage is -10V and +10V.

The on-board dummy load of 330pF//2.5k Ω should be connected to the high voltage pulser output through the solder jumper when using an oscilloscope's high impedance probe to meet the typical loading condition. To evaluate different loading conditions, one may change the values of RC within the current and power limit of the device.

In order to drive the user's piezo transducers with a cable, one should match the output load impedance properly to avoid cable and transducer reflections. A 70 to 75 Ω coaxial cable is recommended. The coaxial cable end should be soldered to the TX1 to 4 and GND directly with very short leads. If a user's load is being used, the on-board dummy load should be disconnected by cutting the small shorting copper trace in between the zero ohm resistors R7, R8, R9 or R10 pads. They are shorted by factory default.

All the on-board test points are designed to work with the high impedance probe of the oscilloscope. Some probes may have limited input voltage. When using the probe on these high voltage test-points, make sure that V_{PP}/V_{NN} voltages do not exceed the probe limit. Using the high impedance oscilloscope probe for the on-board test points, it is important to have short ground leads to the circuit board ground plane. Precautions need to be applied to not overlap the logic-high time periods of the control signals. Otherwise, permanent damage to the device may occur when cross-conduction or shoot-through currents exceed the device's maximum limits.

HV758DB1 Schematic

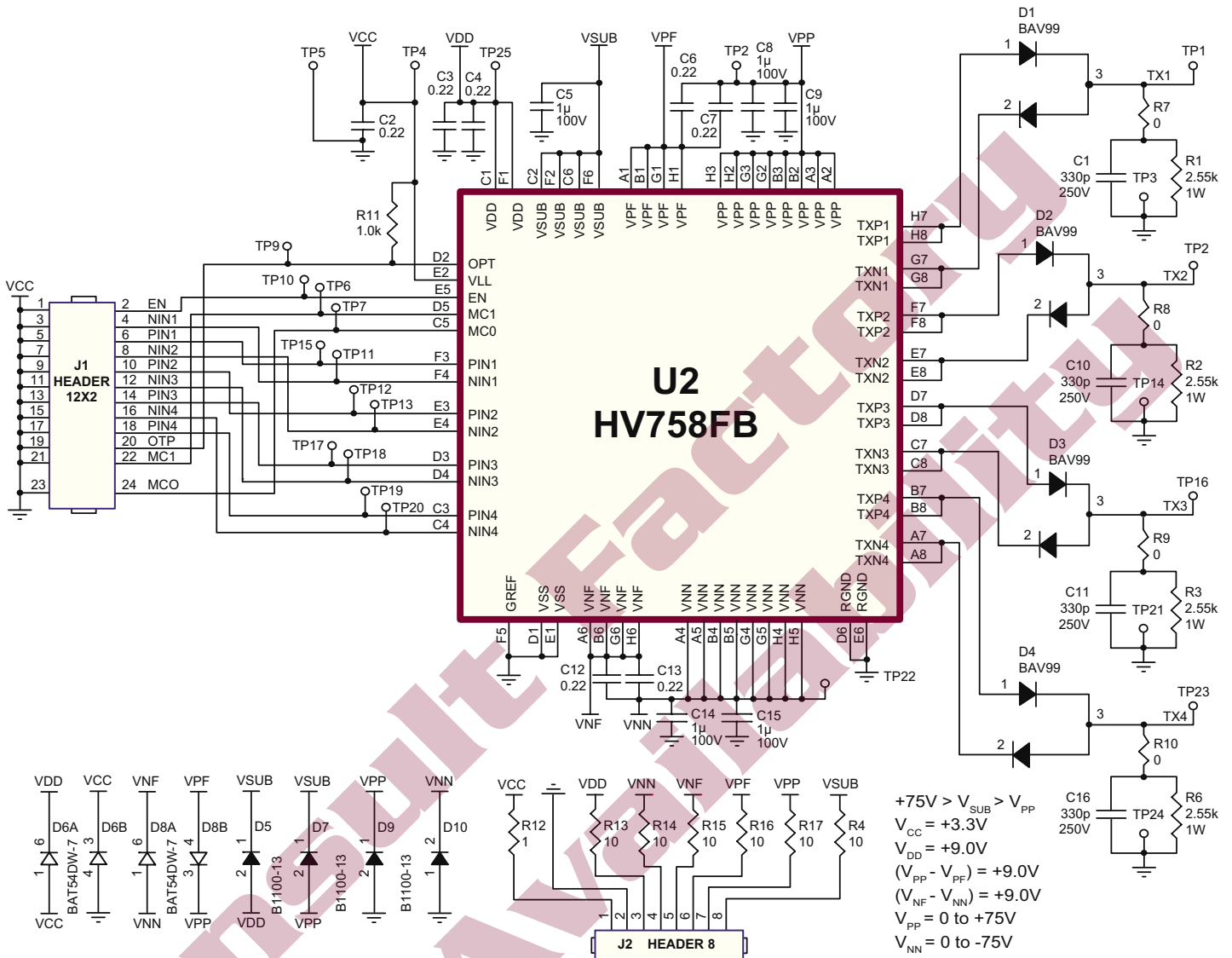

HV758DB1 PCB

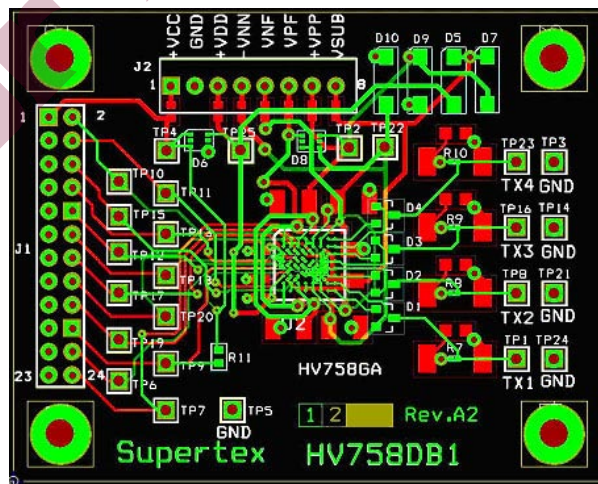

Board Voltage Supply Power-Up Sequence

1	V_{SUB}	+90V > V_{SUB}/V_{PP} positive bias voltages
2	V_{CC}	+1.8 to 5.0V positive logic supply voltage for HV758 V_{LL} and user logic circuit
3	V_{DD}	+10V positive drive supply voltage
4	V_{PF} and V_{NF}	Floating supply voltages, $(V_{PP} - V_{PF}) = +10V$ and $(V_{NF} - V_{NN}) = +10V$
5	V_{PP} / V_{NN}	0 to +/-90V positive and negative high voltages
6	Logic Active	Any logic control active high signals

Connector and Test Pin Description

Logic Control Signal Input Connector

1	V_{CC}	Logic-high reference voltage input, Pin-48 V_{LL} , +1.8 to 5.0V, normally from control circuit.
2	EN	Pulser output enable logic signal input, active high.
3	GND	Logic signal ground, 0V. ⁽²⁾
4	NIN1	Logic signal input for CH1 negative pulse output, active high. ⁽¹⁾
5	GND	Logic signal ground, 0V.
6	PIN1	Logic signal input for CH1 positive pulse output, active high. ⁽¹⁾
7	GND	Logic signal ground, 0V.
8	NIN2	Logic signal input for CH2 negative pulse output, active high. ⁽¹⁾
9	GND	Logic signal ground, 0V.
10	PIN2	Logic signal input for CH2 positive pulse output, active high. ⁽¹⁾
11	GND	Logic signal ground, 0V.
12	NIN3	Logic signal input for CH3 negative pulse output, active high. ⁽¹⁾
13	GND	Logic signal ground, 0V.
14	PIN3	Logic signal input for CH3 positive pulse output, active high. ⁽¹⁾
15	GND	Logic signal ground, 0V.
16	NIN4	Logic signal input for CH4 negative pulse output, active high. ⁽¹⁾
17	GND	Logic signal ground, 0V.
18	PIN4	Logic signal input for CH4 positive pulse output, active high. ⁽¹⁾
19	GND	Logic signal ground, 0V.
20	OTP	Over temperature protection open drain output, active low, 1k pull-up to V_{CC} .
21	GND	Logic signal ground, 0V.
22	MC1	Logic signal input of mode control MSB.
23	GND	Logic signal ground, 0V.
24	MC0	Logic signal input of mode control LSB.

Power Supply Connector

1	V_{CC}	Logic-high reference voltage supply, +1.8 to 5.0V current limit 5.0mA (for V_{LL} only).
2	GND	Low voltage power supply ground, 0V
3	V_{DD}	+10V positive driver voltage supply with current limit to 10mA.
4	V_{NN}	0 to -90V negative high voltage supply with current limit to 5.0mA
5	V_{NF}	Floating voltage supply $(V_{NF} - V_{NN}) = +10V$ with current limit to 10mA. ⁽³⁾
6	V_{PF}	Floating voltage supply $(V_{PP} - V_{PF}) = +10V$ with current limit to 10mA. ⁽³⁾
7	V_{PP}	0 to +90V positive high voltage supply with current limit to 2.0mA
8	V_{SUB}	Chip substrate bias voltage, must be $(+90V > V_{SUB}/V_{PP})$ with limit to 5.0mA

Note:

- (1). Overlap control signals logic-high periods of PIN and NIN may cause the device permanent damage.
- (2). Due to the speed of logic control signal, every GND wire in the ribbon cable must connect to signal source ground.
- (3). $(V_{PP} - V_{PF})$ and $(V_{NF} - V_{NN})$ floating voltage can be trimmed from +8.0V to +12V for t/t_i time matching. Do not exceed the maximum +12V.

HV758DB1 Waveforms

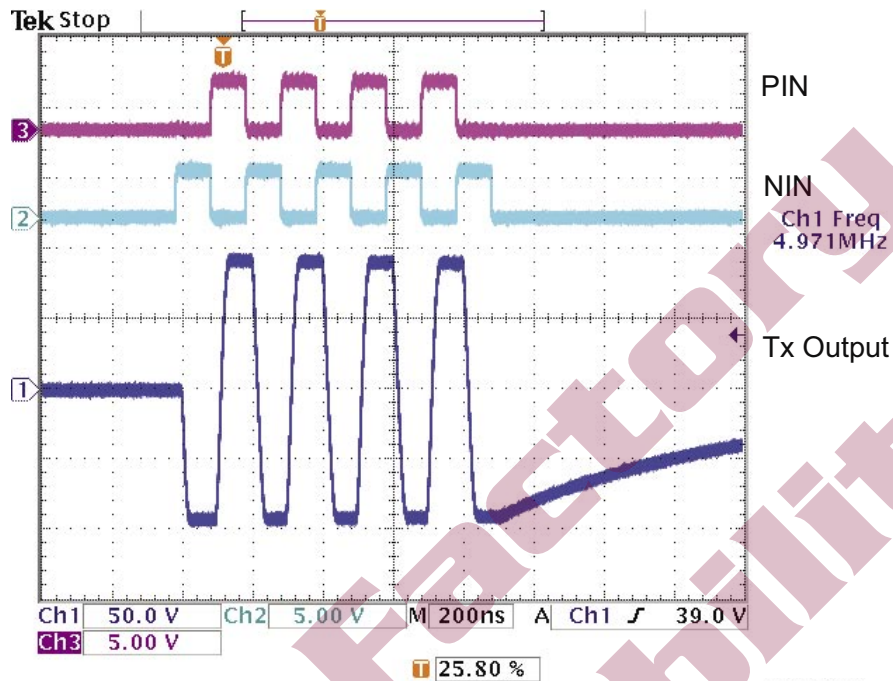

Figure 1: PIN, NIN and output waveform of 5MHz, $V_{LL} = 3.3V$, $V_{DD} = +10V$, $(V_{PP} - V_{PF}) = +10V$, $(V_{NF} - V_{NN}) = +10V$, $V_{PP}/V_{NN} = +/-90V$, $V_{SUB} = +95V$ with load of 330pF//2.5K, at MC0 = MC1 = 1.

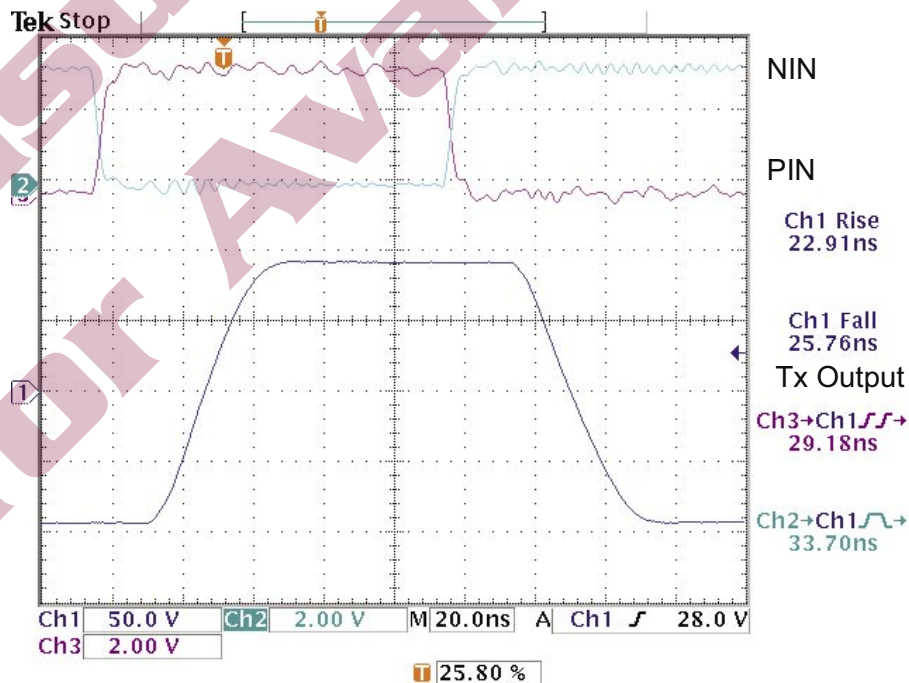

Figure 2: Input to output propagation delay on rise is 29ns and on fall is 33.7ns and the tr/ff time is 22.9/25.8ns $V_{LL} = 3.3V$, $V_{DD} = +10V$, $(V_{PP} - V_{PF}) = +10V$, $(V_{NF} - V_{NN}) = +10V$, $V_{PP}/V_{NN} = +/-90V$, $V_{SUB} = +95V$ with load of 330pF//2.5K, at MC0 = MC1 = 1.

HV758DB1 Waveforms

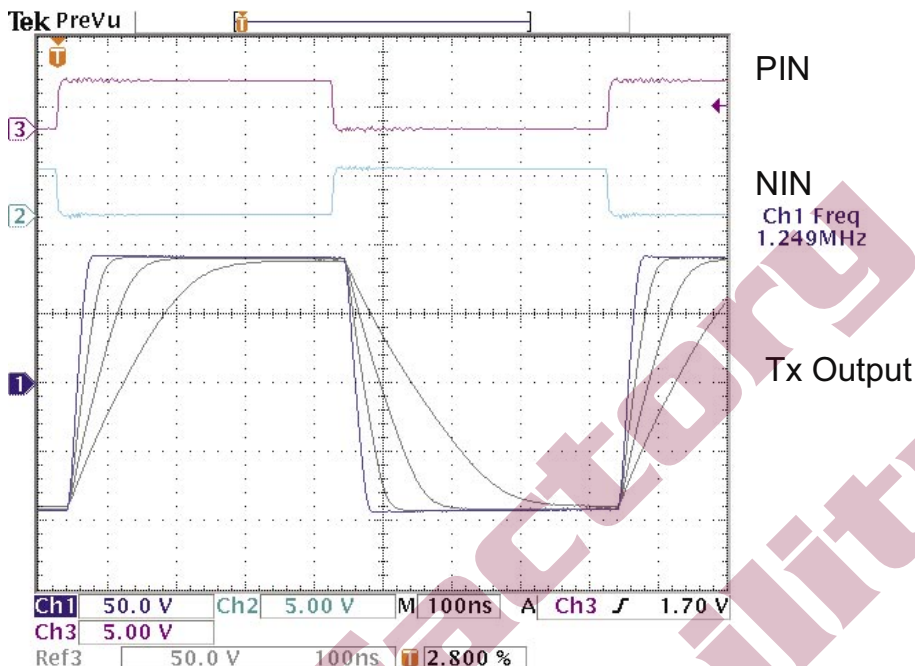

Figure 3: PIN, NIN and OUTPUT at 1.25MHz, $V_{DD} = +10V$, $(V_{PP} - V_{PF}) = +10V$, $(V_{NF} - V_{NN}) = +10V$, $V_{PP}/V_{NN} = +/-90V$, $V_{SUB} = +95V$ with load of 330pF//2.5KΩ, Load = 330pF//2.49kΩ, Mode 1 through 4 current modes.

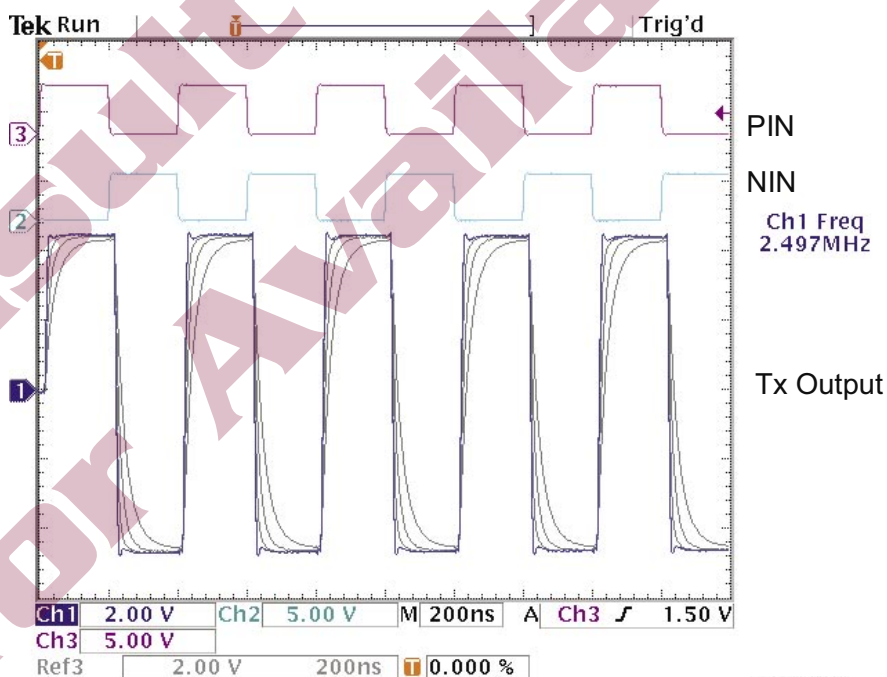

Figure 4: PIN, NIN and OUTPUT at 2.5MHz, $V_{DD} = +10V$, $(V_{PP} - V_{PF}) = +10V$, $(V_{NF} - V_{NN}) = +10V$, $V_{PP}/V_{NN} = +/-5.0V$, $V_{SUB} = +95V$ with load of 330pF//2.5KΩ, Load = 330pF//2.49kΩ, Mode 1 through 4 current modes.

Supertex inc. does not recommend the use of its products in life support applications, and will not knowingly sell them for use in such applications unless it receives an adequate "product liability indemnification insurance agreement." **Supertex inc.** does not assume responsibility for use of devices described, and limits its liability to the replacement of the devices determined defective due to workmanship. No responsibility is assumed for possible omissions and inaccuracies. Circuitry and specifications are subject to change without notice. For the latest product specifications refer to the **Supertex inc.** (website: <http://www.supertex.com>)