

# FAN8423D3

## 3-Phase BLDC Motor Driver

### Features

- 3-phase, full-wave, linear BLDC motor driver
- Power save at stop mode
- Built-in current limiter
- Built-in TSD (thermal shutdown) circuit
- Built-in 3X and 1X hall FG output
- Built-in hall bias circuit
- Built-in rotational direction detector
- Built-in reverse rotation preventer
- Built-in short braker
- Corresponds to 5 V DSP

### Description

The FAN8423D3 is a monolithic IC, suitable for a 3-phase spindle motor driver of a CD-media system.

28-SSOPH-375SG2



### Typical Applications

- Compact disk ROM (CD-ROM) spindle motor
- Compact disk RW (CD-RW) spindle motor
- Digital video disk ROM (DVD-ROM) spindle motor
- Digital video disk RAM (DVD-RAM) spindle motor
- Digital video disk Player (DVDP) spindle motor
- Other compact disk media spindle motor
- Other 3-phase BLDC motor

### Ordering Information

Device	Package	Operating Temp.
FAN8423D3	28-SSOPH-375SG2	-25°C ~ +75°C
FAN8423D3TF	28-SSOPH-375SG2	-25°C ~ +75°C

## Pin Assignments

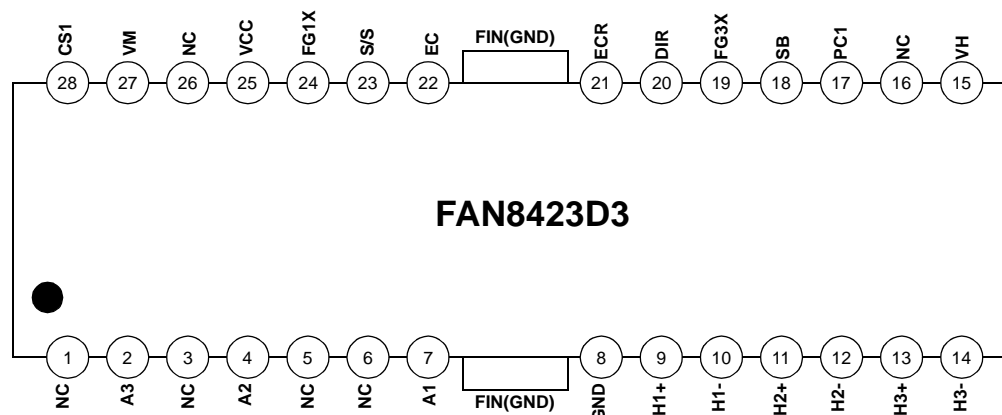

## Pin Definitions

Pine Number	Pin Name	I/O	Pin Function Description
1	NC	-	No connection
2	A3	O	Output (A3)
3	NC	-	No connection
4	A2	O	Output (A2)
5	NC	-	No connection
6	NC	-	No connection
7	A1	O	Output (A1)
8	GND	-	Ground
9	H1+	I	Hall signal (H1+)
10	H1-	I	Hall signal (H1-)
11	H2+	I	Hall signal (H2+)
12	H2-	I	Hall signal (H2-)
13	H3+	I	Hall signal (H3+)
14	H3-	I	Hall signal (H3-)
15	VH	I	Hall bias
16	NC	-	No connection
17	PC1	-	Phase compensation capacitor
18	SB	I	Short brake
19	FG3X	O	FG waveform (3X)
20	DIR	O	Rotational direction output
21	ECR	I	Output current control reference
22	EC	I	Output current control voltage
23	S/S	I	Power save (Start/Stop switch)
24	FG1X	O	FG waveform (1X)
25	VCC	-	Supply voltage (Signal)
26	NC	-	No connection
27	VM	-	Supply voltage (Motor)
28	CS1	-	Output current detection

# Internal Block Diagram

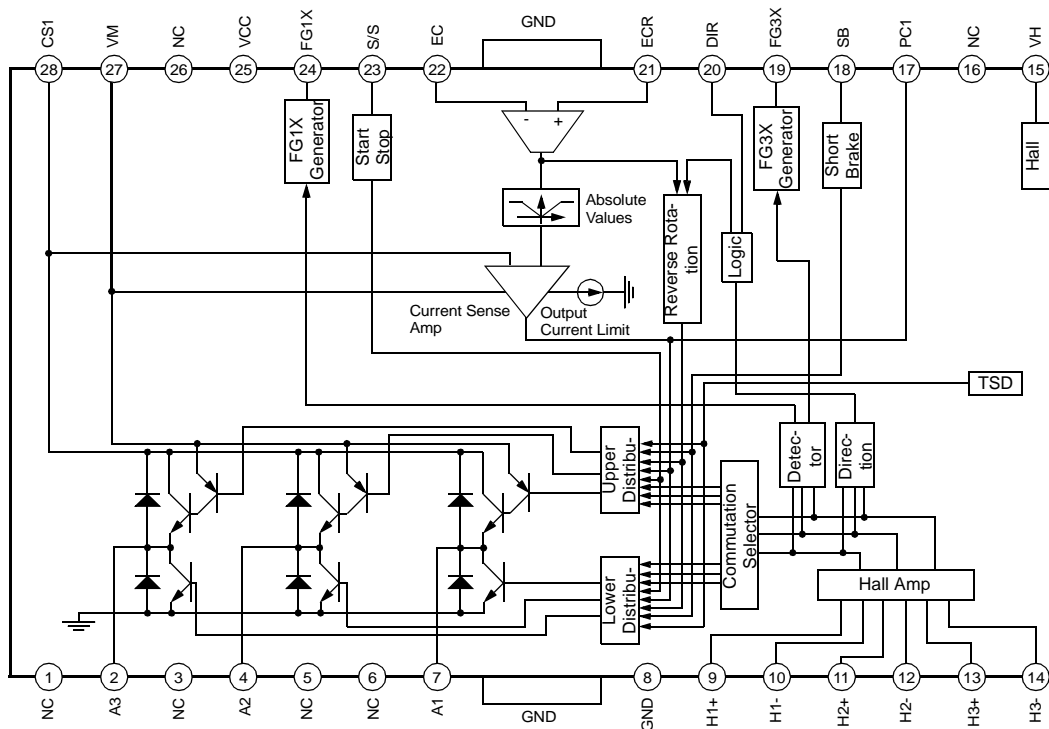

## Equivalent Circuits

Hall Input	Driver Output
Torque Control Input	Hall Bias Input
Start/stop Input	Short Brake Input
Fg Output	Dir Output

## Absolute Maximum Ratings (Ta = 25°C)

Parameter	Symbol	Value	Unit
Maximum supply voltage (Signal)	V <sub>CCmax</sub>	7	V
Maximum supply voltage (Motor)	V <sub>Mmax</sub>	15	V
Power dissipation	P <sub>D</sub>	2.5 <sup>note</sup>	W
Maximum output current	I <sub>Omax</sub>	1.3	A
Operating temperature range	T <sub>OPR</sub>	-25 ~ +75	°C
Storage temperature range	T <sub>STG</sub>	-55 ~ +150	°C

### NOTE:

1. When mounted on a 76.2mm × 114mm × 1.57mm PCB (Phenolic resin material).
2. Power dissipation reduces 16.6mW/°C for using above Ta = 25°C
3. Do not exceed P<sub>D</sub> and SOA (Safe operating area).

## Power Dissipation Curve

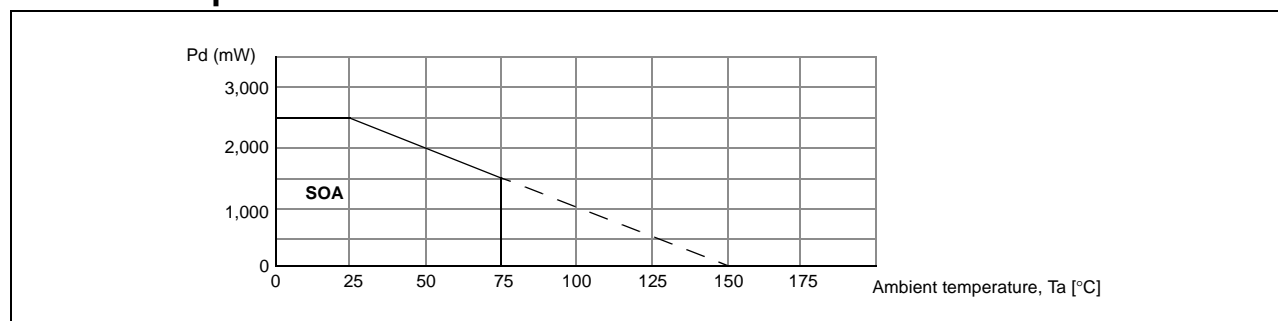

## Recommended Operating Conditions (Ta = 25°C)

Parameter	Symbol	Min.	Typ.	Max.	Unit
Supply Voltage	V <sub>cc</sub>	4.5	5	5.5	V
Motor Supply Voltage	V <sub>M</sub>	3.5	12	14	V

## Electrical Characteristics

(Unless otherwise specified,  $T_a = 25\text{ }^\circ\text{C}$ ,  $V_{cc}=5\text{ V}$ ,  $V_M=12\text{ V}$ )

Parameter	Symbol	Condition	Min.	Typ.	Max.	Unit
Quiescent circuit current 1	$I_{cc1}$	At stop mode	-	-	0.2	mA
Quiescent circuit current 2	$I_{cc2}$	At start mode	-	5	10	mA
<b>START/STOP</b>						
On voltage range	$V_{SSon}$	Output driver ON	2.5	-	$V_{cc}$	V
Off voltage range	$V_{SSoff}$	Output driver OFF	0.0	-	1.0	V
<b>HALL BIAS</b>						
Hall bias voltage	$V_{HB}$	$I_{HB}=20\text{ mA}$	0.4	1.0	1.8	V
<b>HALL AMP</b>						
Hall bias current	$I_{HA}$	-	-	0.5	2	$\mu\text{A}$
Common-mode input range	$V_{HAR}$	-	1.0	-	4.0	V
Minimum input level	$V_{INH}$	-	60	-	-	mVpp
H1 hysteresis level	$V_{HYS}$	-	5	20	40	mVpp
<b>TORQUE CONTROL</b>						
Ecr Input voltage range	$E_{CR}$	-	1.0	-	4.0	V
Ec Input voltage range	$E_C$	-	1.0	-	4.0	V
Offset voltage (-)	$E_{Coff-}$	$E_C=2.5\text{ V}$	-80	-50	-20	mV
Offset voltage (+)	$E_{Coff+}$	$E_C=2.5\text{ V}$	20	50	80	mV
Ec Input current	$E_{Cin}$	$E_C=2.5\text{ V}$	-	0.3	3	$\mu\text{A}$
Ecr Input current	$E_{CRin}$	$E_{cr}=2.5\text{ V}$	-	0.3	3	$\mu\text{A}$
Input/output gain	$G_{EC}$	$E_C=2.5\text{ V}$ , $R_{cs}=0.5\text{ }\Omega$	0.41	0.51	0.61	A / V
<b>FG</b>						
FG output voltage (H)	$V_{FGh}$	$I_{fg}=-10\text{ }\mu\text{A}$	4.5	4.9	-	V
FG output voltage (L)	$V_{FGl}$	$I_{fg}=10\text{ }\mu\text{A}$	-	-	0.5	V
Duty (reference value)	-	-	-	50	-	%
<b>OUTPUT BLOCK</b>						
Saturation voltage (upper TR)	$V_{OH}$	$I_o=-300\text{ mA}$	-	0.9	1.4	V
Saturation voltage (lower TR)	$V_{OL}$	$I_o=300\text{ mA}$	-	0.4	0.7	V
Torque limit current	$I_{TL}$	$R_{CS}=0.5\text{ }\Omega$	560	700	840	mA
<b>DIRECTION DETECTOR</b>						
DIR output voltage (H)	$V_{DIRh}$	$I_{FG}=-10\text{ }\mu\text{A}$	4.5	4.7	-	V
DIR output voltage (L)	$V_{DIRl}$	$I_{FG}=10\text{ }\mu\text{A}$	-	-	0.5	V
<b>SHORT BRAKE</b>						
ON voltage range	$V_{SBon}$	-	2.5	-	$V_{cc}$	V
OFF voltage range	$V_{SBoff}$	-	0	-	1.0	V



# Application Information

## 1. Torque Control & Output Current Control

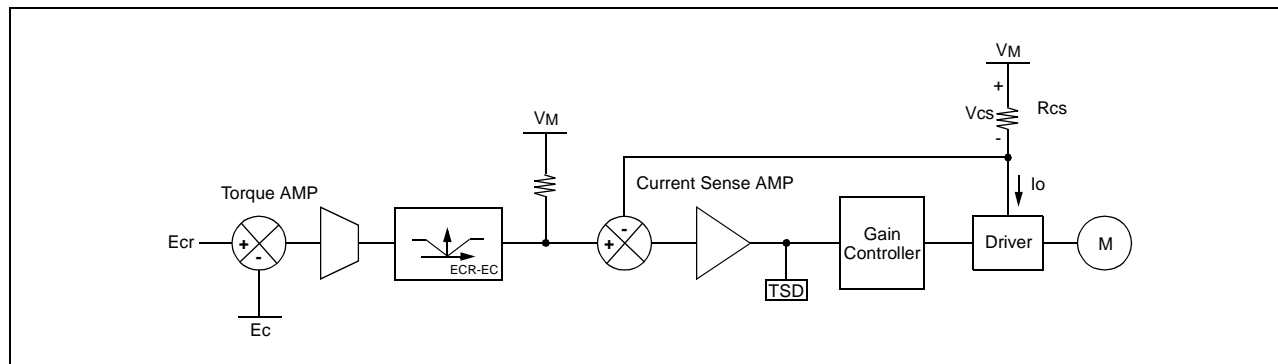

- 1) By amplifying the voltage difference between  $E_c$  and  $E_{cr}$  from Servo IC, the Torque Sense AMP produces the input ( $V_{AMP}$ ) for the Current Sense AMP.
- 2) The output current ( $I_O$ ) is converted into the voltage ( $V_{CS}$ ) through the sense resistor ( $R_{CS}$ ) and compared with the  $V_{AMP}$ . By the negative feedback loop, the sensed output voltage,  $V_{CS}$  is equal to the input  $V_{AMP}$ . Therefore, the output current ( $I_O$ ) is linearly controlled by the input  $V_{AMP}$ .
- 3) As a result, the signals,  $E_C$  and  $E_{CR}$  can control the velocity of the Motor by controlling the output current ( $I_O$ ) of the Driver.
- 4) The range of the torque voltage is as shown below.

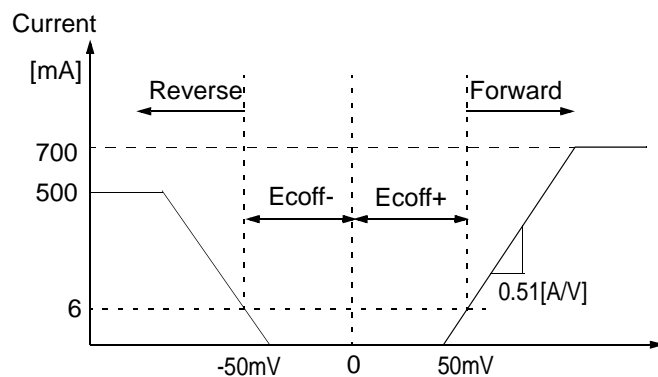

	Rotation
$E_{CR} > E_C$	Forward rotation
$E_{CR} < E_C$	Stop after detecting reverse rotation

The input range of  $E_{CR}$  and  $E_C$  is 1.0 V ~ 4 V (  $R_{NF} = 0.5[\Omega]$  )



## 2. Short Brake

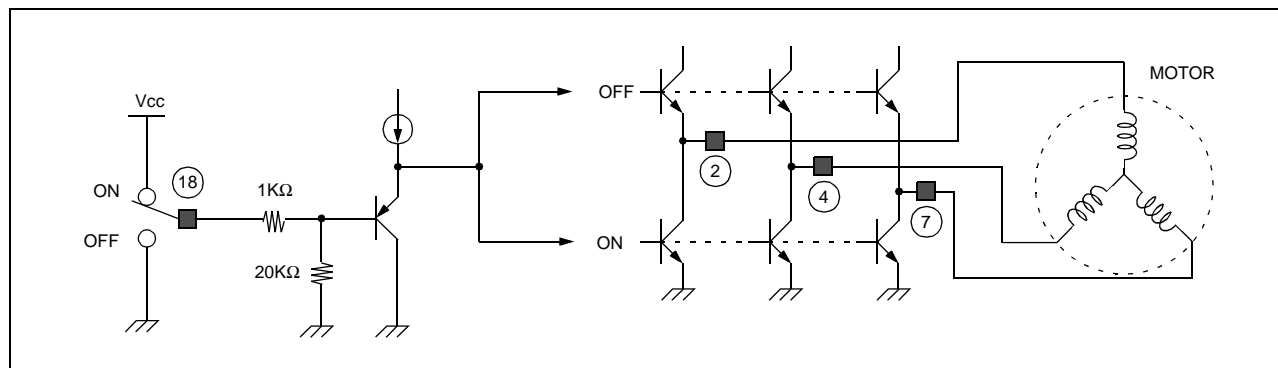

Pin # 18	Short Brake
High	ON
Low	OFF

When the pick-up mechanism moves from the inner to the outer spindle of the CD, the Brake function of the reverse voltage is commonly employed to decrease the rotating velocity of the Spindle Motor.

However, if the Spindle Motor rotates rapidly, the Brake function of the reverse voltage may produce more heat at the Drive IC.

To remove this shortcoming and to enhance the braking efficiency, the Short Brake function is added to FAN8423D3. When the Short Brake function is active, all upper Power TRs turn off and all lower Power TRs turn on. This slows down the motor.

## 3. Start/stop (Power Save)

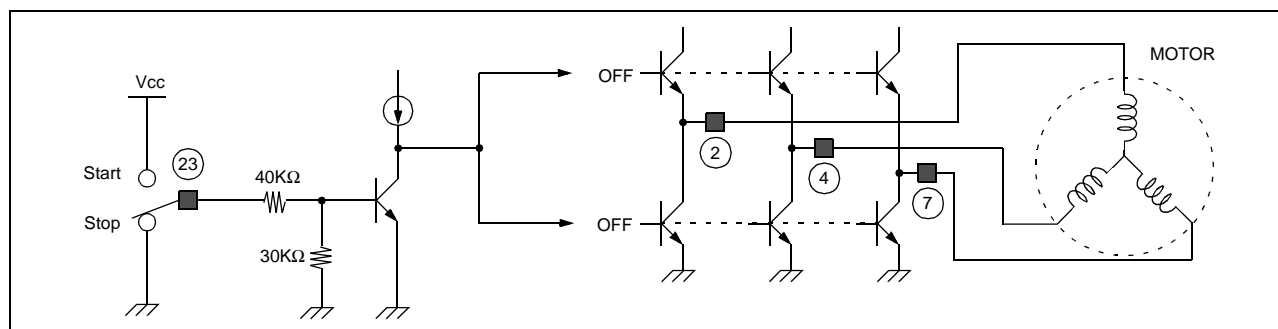

Pin # 23	Start/Stop
High	Operate
Low	Stop

When Start/Stop function is active, all Power TRs turn off.

#### 4. Tsd (Thermal Shutdown)

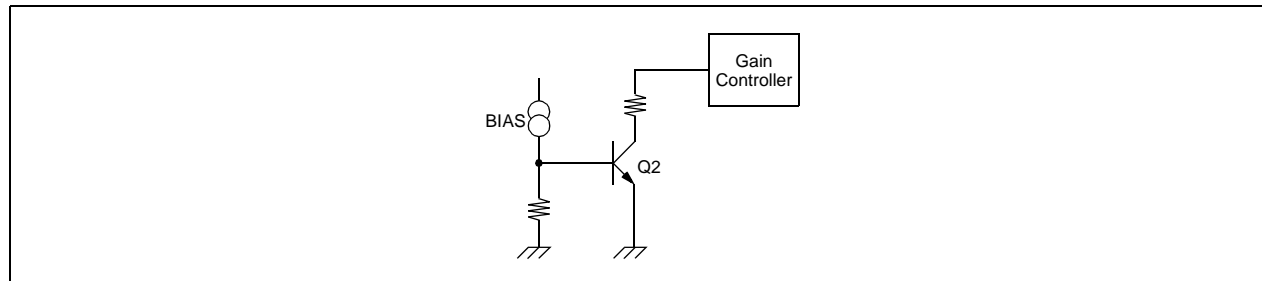

When the chip temperature rises up to about 175°C, the Q2 turns on so that the output driver shuts down. When the chip temperature falls off to about 150°C, then the Q2 turns off so that the driver is to operate normally. TSD has the temperature hysteresis of about 25°C.

#### 5. Rotational Direction Detection

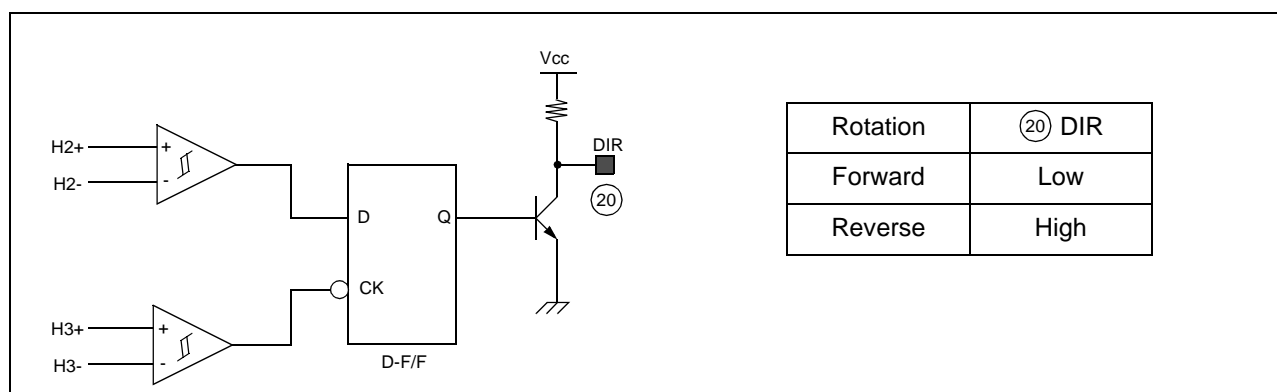

- 1) The forward and the reverse rotations of the CD are detected by using the D-F/F and the truth table as shown above.
- 2) The rotational direction of the CD can be explained by the output waveform of the Hall sensors. Let the three outputs of Hall sensors be H1, H2 and H3 respectively. When the spindle rotates in reverse direction, the Hall sensor output waveform are shown in Fig.(a). Thus the phases are in order H1→H2→H3 with a 120° phase difference.

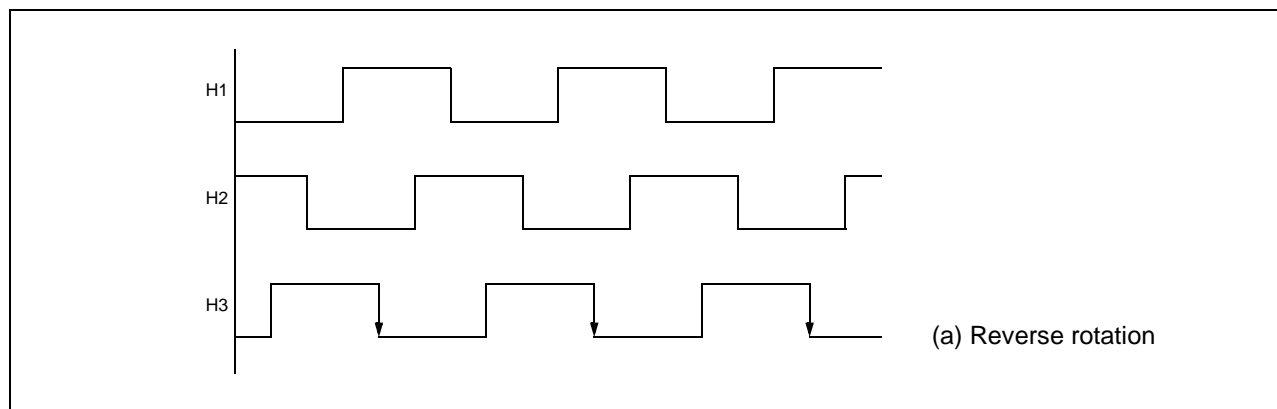

On the other hand, if the spindle rotates in forward rotation, the phase relationship is H3→H2→H1 as shown in Fig.(b)

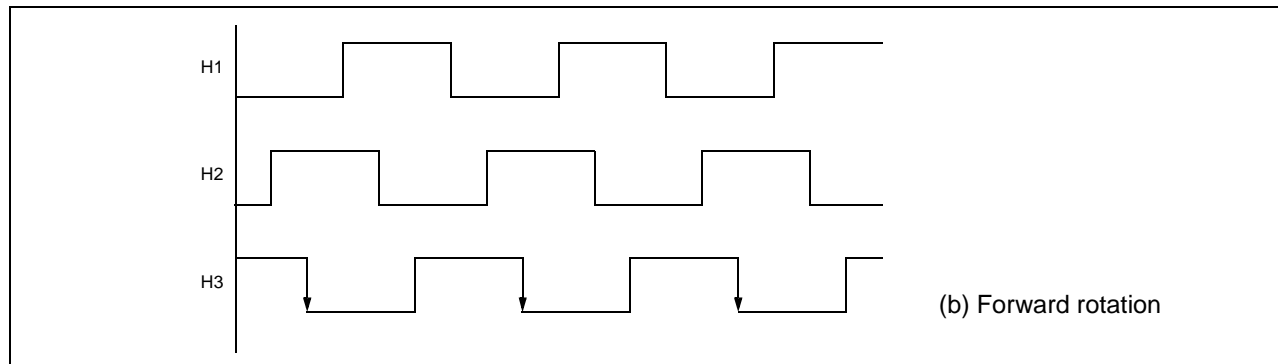

Therefore, the output of the rotational direction detector is Low, when the spindle rotates forward, while HIGH as in the case of the reverse rotation.

## 6. Reverse Rotation Prevention

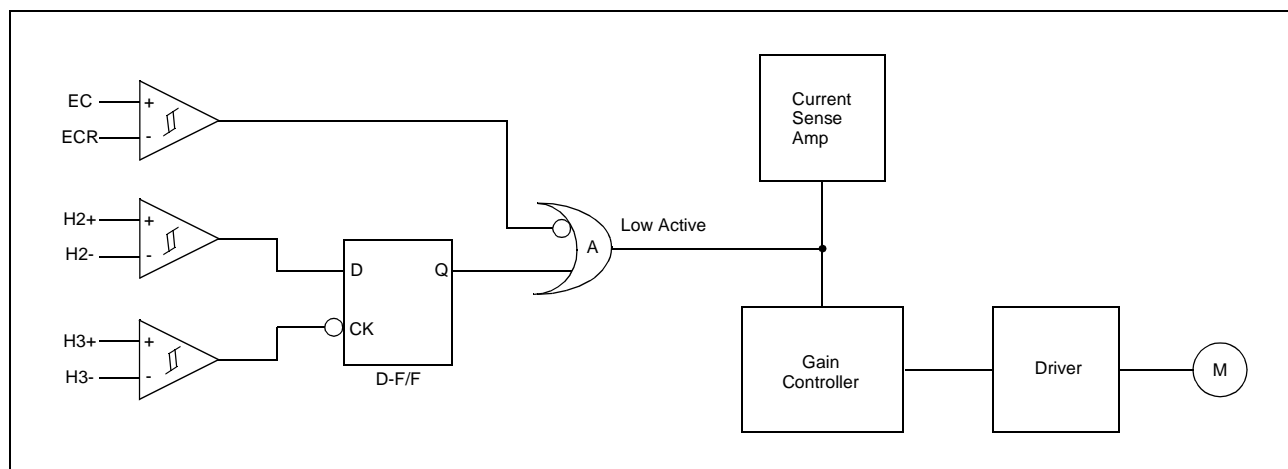

- 1) When the output of the OR Gate, A is LOW, it steers all the output current of the current sense Amp to the Gain Controller zero. The output current of the Driver becomes zero and the motor stops.
- 2) As in the state of the forward rotation, the D-F/F output, Q is HIGH and the motor rotates normally. At this state, if the control input is changed such that  $EC > ECR$ , then the motor rotates slowly by the reverse commutation in the Driver. When the motor rotates in reverse direction, the D-F/F output becomes Low and the OR Gate output, becomes LOW. This prevents the motor from rotating in reverse direction. The operation principle is shown in the table and the flow chart.

Rotation	H2	H3	D-F/F (Q)	Reverse Rotation Preventer	
				$EC < ECR$	$EC > ECR$
Forward	H	H→L	H	Forward	-
Reverse	L	H→L	L	-	Brake and Stop

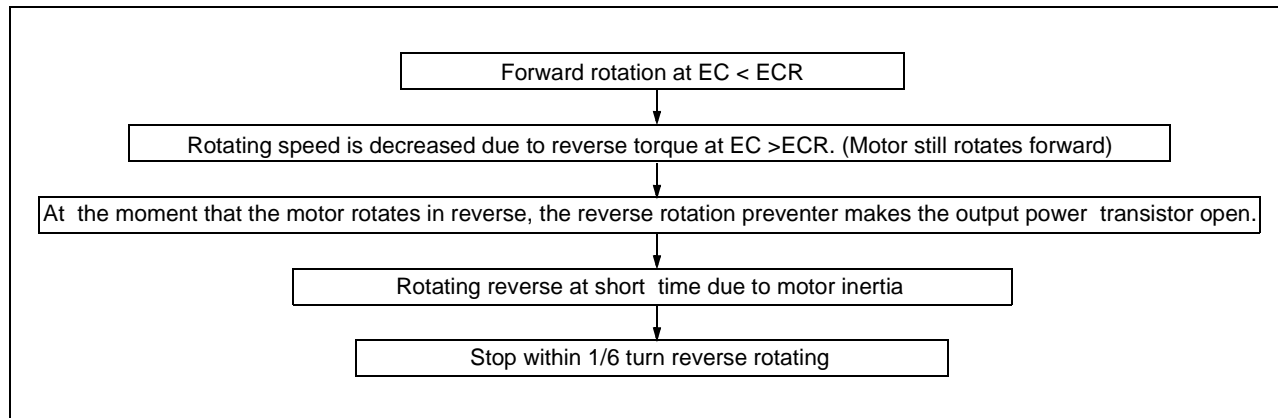

### 7. Fg Output

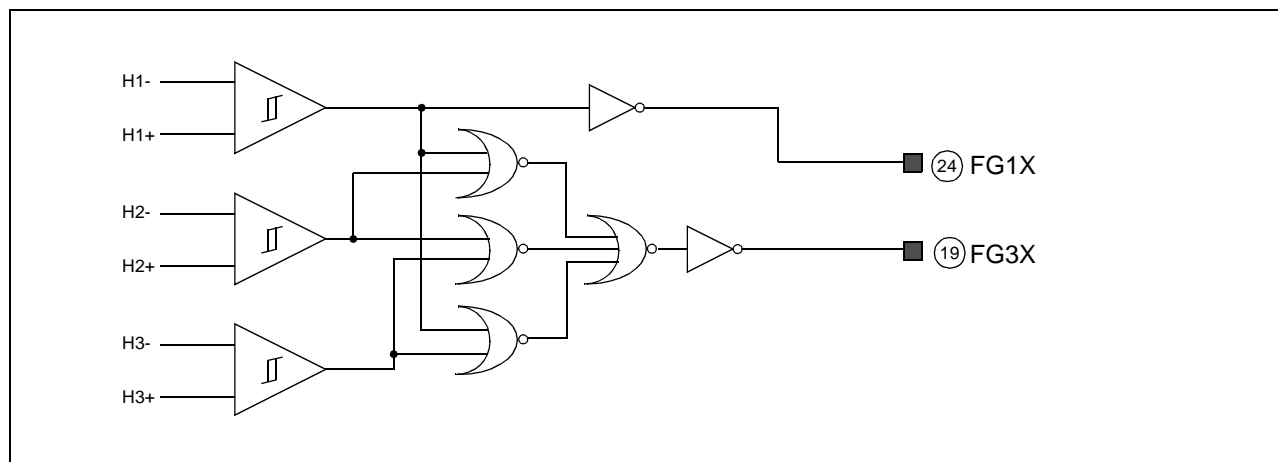

### 8. Hall Sensor Connection

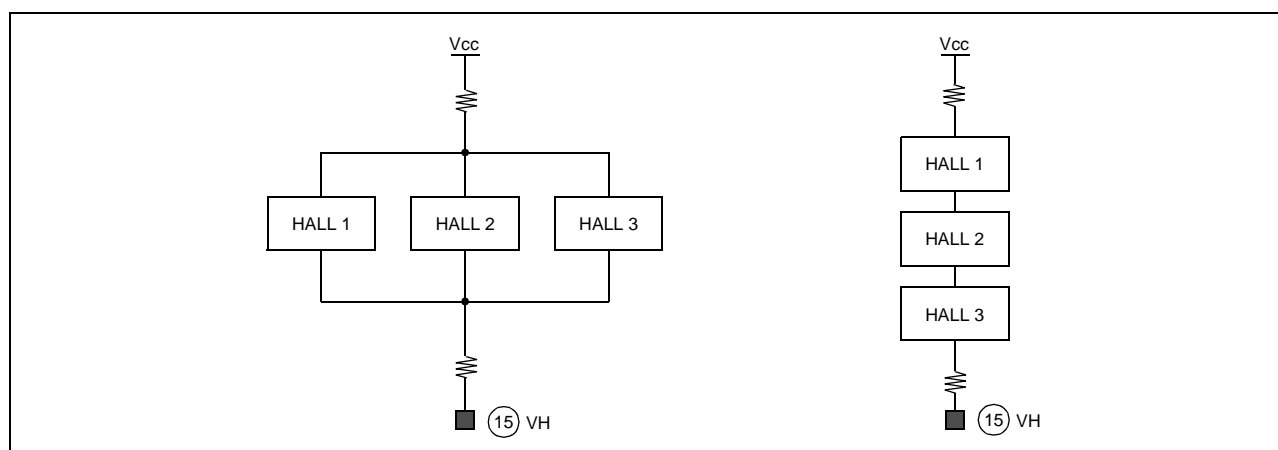

## 9. Connect A By-pass Capacitor, 0.1 $\mu$ f Between The Supply Voltage Source

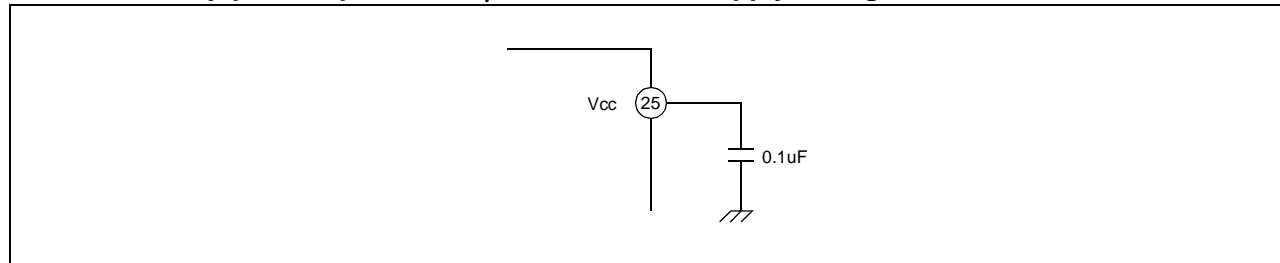

- (1) The heat radiation fin is connected to the internal Gnd of the package.  
Connect that fin to the external Gnd.

### 10. Input-output Timing Chart

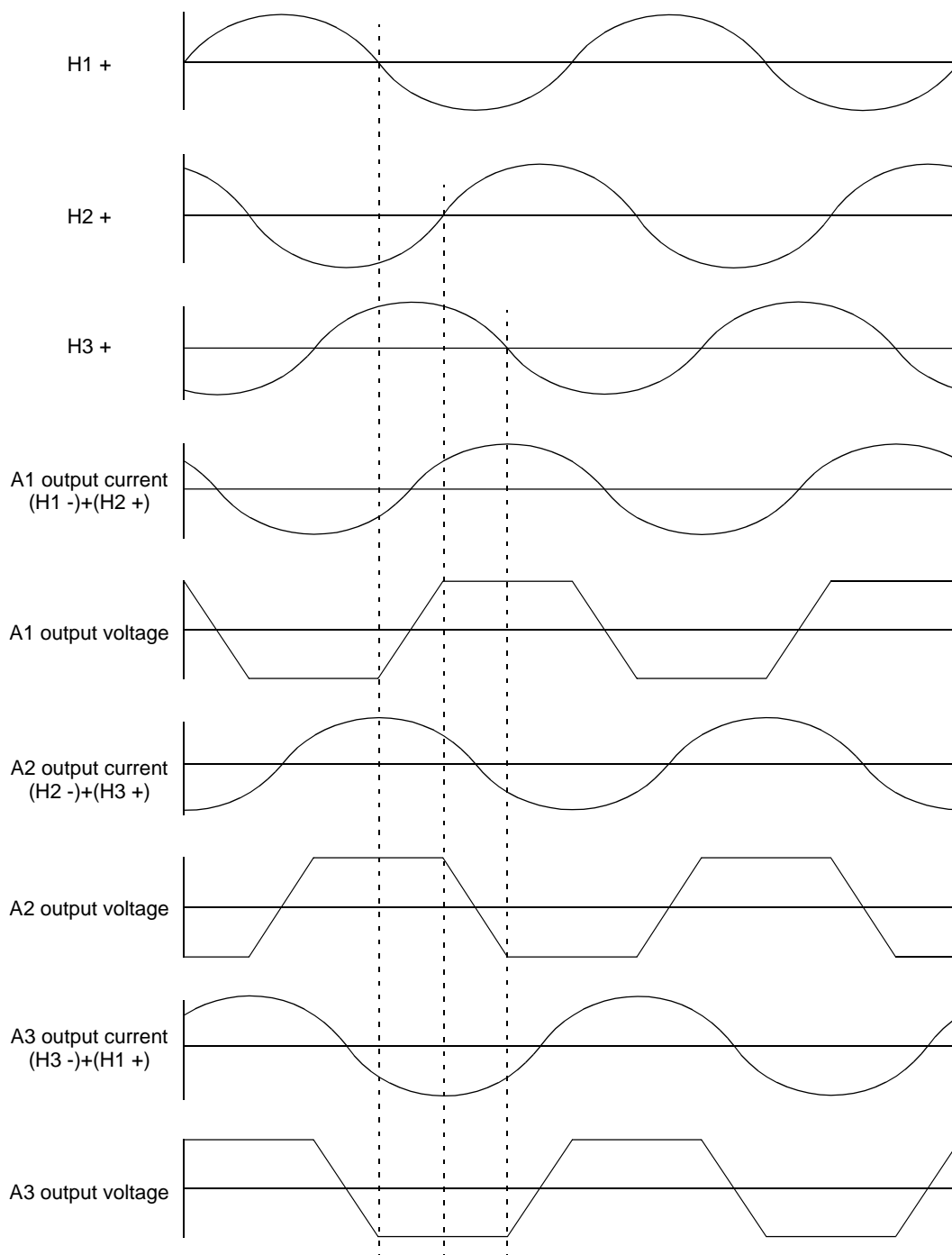

# Test Circuits

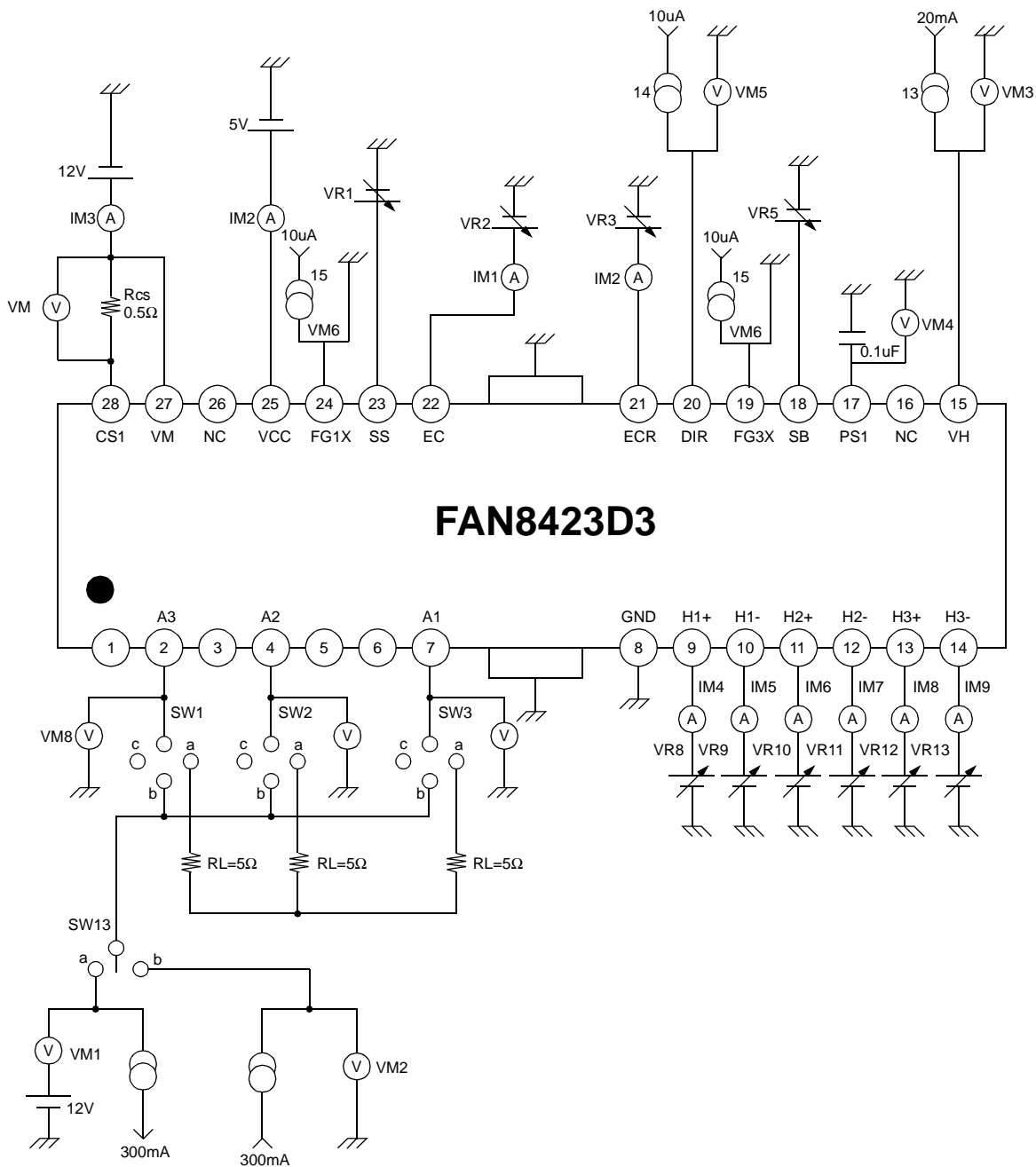

## Typical Application circuits

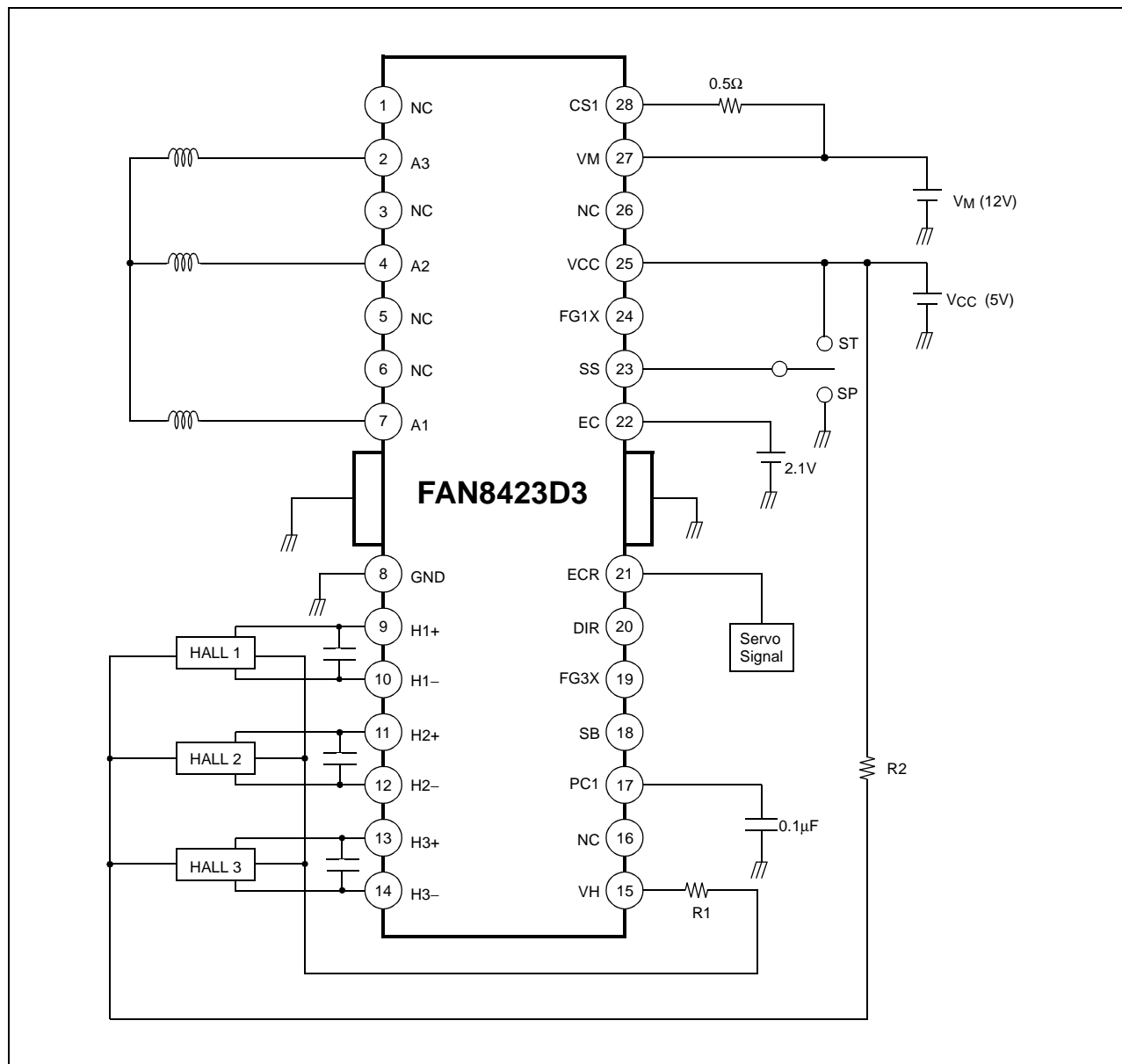





#### **DISCLAIMER**

FAIRCHILD SEMICONDUCTOR RESERVES THE RIGHT TO MAKE CHANGES WITHOUT FURTHER NOTICE TO ANY PRODUCTS HEREIN TO IMPROVE RELIABILITY, FUNCTION OR DESIGN. FAIRCHILD DOES NOT ASSUME ANY LIABILITY ARISING OUT OF THE APPLICATION OR USE OF ANY PRODUCT OR CIRCUIT DESCRIBED HEREIN; NEITHER DOES IT CONVEY ANY LICENSE UNDER ITS PATENT RIGHTS, NOR THE RIGHTS OF OTHERS.

#### **LIFE SUPPORT POLICY**

FAIRCHILD'S PRODUCTS ARE NOT AUTHORIZED FOR USE AS CRITICAL COMPONENTS IN LIFE SUPPORT DEVICES OR SYSTEMS WITHOUT THE EXPRESS WRITTEN APPROVAL OF THE PRESIDENT OF FAIRCHILD SEMICONDUCTOR INTERNATIONAL. As used herein:

1. Life support devices or systems are devices or systems which, (a) are intended for surgical implant into the body, or (b) support or sustain life, and (c) whose failure to perform when properly used in accordance with instructions for use provided in the labeling, can be reasonably expected to result in a significant injury of the user.
2. A critical component in any component of a life support device or system whose failure to perform can be reasonably expected to cause the failure of the life support device or system, or to affect its safety or effectiveness.