

Heatsink Encased Wirewound Power Resistors

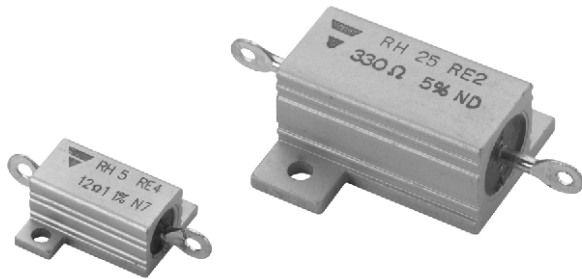

FEATURES

- 5 Watt to 50 Watt at 25 °C
- NF C 83-210
- CECC 40 203
- High stability < 0.05 % year
- Low temperature coefficient typically ± 15 ppm/°C
- Wide range of values from 0.006 Ω to 130 k Ω
- Termination = Sn/Ag/Cu



RoHS
COMPLIANT

Encased in a compact and light heatsink offering complete environmental protection, great mechanical strength and easy mounting. Non inductive versions can be supplied under the RHNI designation (please indicate required specifications and frequency range upon ordering).

DIMENSIONS in millimeters

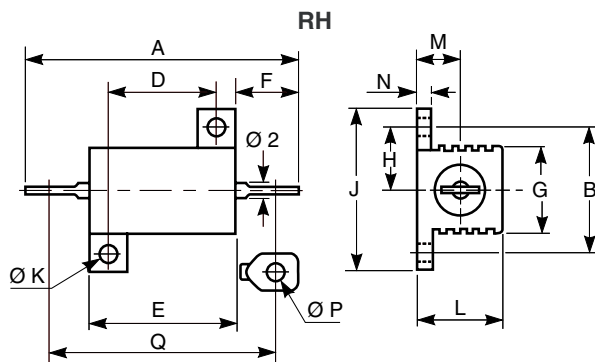

MODEL AND STYLE	RH5	RH10	RH25	RH50
A	28.5 ± 1.5	35 ± 1.5	49 ± 1.3	70.2 ± 1.4
B ± 0.2	12.5	15.9	19.8	21.4
D ± 0.2	11.3	14	18.3	39.7
E ± 0.5	16.3	19	28	50
F	6.8 ± 1.5	7.9 ± 1.5	11.1 ± 1.5	11 ± 1.2
G ± 1	8.5	11	14	15.5
H ± 0.7	6.2	7.9	9.9	10.7
J ± 0.5	16.4	20.6	27.5	29.4
Ø K ± 0.1	2.4	2.4	3.2	3.2
L max.	8.9	11	15	15
M ± 0.5	4.3	5.6	8	8
N ± 0.3	1.6	2	2.4	2.4
Ø P min.	2.1	2.1	2.1	2.1
Q	25.3 ± 1.5	30.6 ± 1.5	44.6 ± 1.3	66.5 ± 1.4
Weight in g	3	8.8	16.5	30.8

ELECTRICAL SPECIFICATIONS							
VISHAY SFERNICE MODEL AND STYLE			RH5	RH10	RH25	RH50	
NF C 83-210 (CECC 40 203)			RE4	RE1	RE2	RE3	
Power Rating	Chassis Mounted Resistors	MIL Limits	25 °C	5 W	10 W	20 W	30 W
		70 °C	4 W	8 W	16 W	24 W	
	413 cm ² for RH5 and RH10 536 cm ² for RH25 and RH50	VISHAY SFERNICE Limits	25 °C	10 W	12.5 W	25 W	50 W
		70 °C	8 W	10 W	20 W	40 W	
Unmounted Resistors	VISHAY SFERNICE Limits	25 °C	4 W	6 W	9W	12 W	
		70 °C	3.2 W	4.8 W	7.2 W	9.6 W	
Rated Maximum Voltage (VRMS)			160 V	250 V	550 V	1285 V	
Dielectric Strength VRMS			1000 V	1500 V	2500 V	2500 V	
Ohmic Range			VISHAY SFERNICE				
			0.01 Ω 12 k Ω	0.006 Ω 20 k Ω	0.006 Ω 62 k Ω	0.006 Ω 130 k Ω	
Qualified Ohmic Range			NF C 83-210				
			0.1 Ω 2.7 k Ω	0.1 Ω 4.99 k Ω	0.1 Ω 11.8 k Ω	0.1 Ω 33.2 k Ω	
Minimum Ohmic Values in Relation to Tolerance	E 96	± 0.1 %	1 Ω		1 Ω		
	E 96	± 0.5 %	0.1 Ω		0.1 Ω		
	E 96	± 1 %	0.1 Ω		0.05 Ω		
	E 48	± 2 %	0.01 Ω		0.01 Ω		
	E 24	± 5 %	0.01 Ω		0.01 Ω		
	E 12	± 10 %	0.01 Ω	0.008 Ω	0.006 Ω		

 Undergoes European Quality Insurance System (CECC)



PERFORMANCE					
		MIL-R-18546 D	NF C 83-210		
TESTS	CONDITIONS		REQUIREMENTS	TYPICAL DRIFTS	
Operating Temperature Range	- 55 °C + 200 °C		-	-	
Momentary Overload	5 Pr/5 s		± (0.25 % + 0.05 Ω)	± (0.1 % + 0.05 Ω)	
Climatic Sequence	- 55 °C + 200 °C 5 cycles		± (0.25 % + 0.05 Ω)	± (0.1 % + 0.05 Ω)	
Load Life Test at High Temperature	2 h at + 275 °C		± (1 % + 0.05 Ω) Ins. resistance ≥ 1 GΩ	± (0.1 % + 0.05 Ω)	
Humidity (Steady State)	56 days		± (1 % + 0.05) Ins. resistance ≥ 100 MΩ	± (0.5 % + 0.05 Ω)	
Resistance to Moisture	Climatic sequences test, with load and polarisation		± (1 % + 0.05 Ω)	± (0.5 % + 0.05 Ω)	
Temperature Coefficient	5 to 10 > 10		± 50 ppm/°C ± 25 ppm/°C	± 15 ppm/°C	
Load Life at Maximum Temperature	1000 h 25 °C	Pn MIL	VISHAY	± (1 % + 0.05 Ω)	± (0.1 % + 0.05 Ω)
	200 °C	30 % of Pn	SFERNICE	Ins. resistance ≥ 1 GΩ	± (0.5 % + 0.05 Ω)

MOMENTARY OVERLOAD

1. Momentary overload (> 2 s):

See example in table below. In all cases, it should be understood that:

- the 12 Pn overload applies only to ohmic values 0.1.
- the overload voltage shall not be higher than that used for the dielectric strength test (see Standard Electrical Specifications).

2. Short time overload (< 2 s):

For times shorter than 2 seconds, higher overloads can be sustained in some cases. Consult VISHAY SFERNICE.

POWER LOADING	DURATION
2.5 Pn	10 s
5 Pn	5 s
12 Pn	2 s

POWER RATING CHART

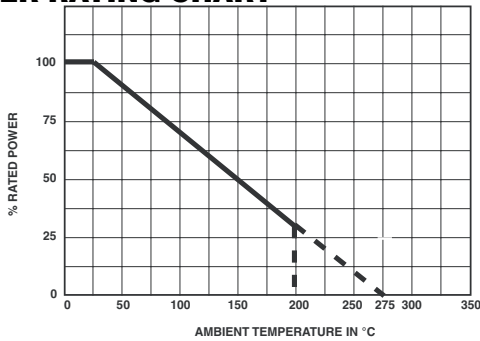

TEMPERATURE RISE

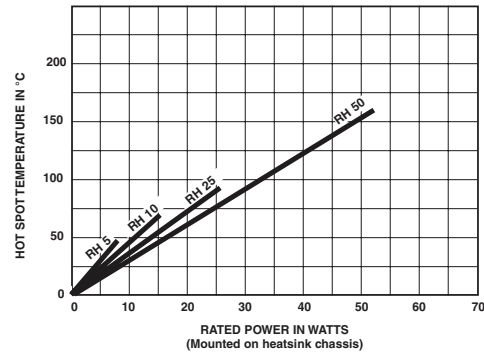

MARKING

VISHAY SFERNICE trademark, model, style, CECC style (if applicable) nominal resistance (in Ω), tolerance (in %), manufacturing date.

PACKAGING

Bag of 10 units

ORDERING INFORMATION							
RH	5	NI		18U	± 5 %	BA10	e1
MODEL	STYLE	NON INDUCTIVE WINDING Optional	SPECIAL DESIGN Method N° Optional	OHMIC VALUE Custom items are subject to extra-charge and min. order. Please see price list.	TOLERANCE	PACKAGING	LEAD (Pb)-FREE

SAP PART NUMBERING GUIDELINES					
RH	05	N	18R00	J	S03
MODEL	STYLE	NON INDUCTIVE WINDING Optional	OHMIC VALUE	TOLERANCE	PACKAGING



Disclaimer

All product specifications and data are subject to change without notice.

Vishay Intertechnology, Inc., its affiliates, agents, and employees, and all persons acting on its or their behalf (collectively, "Vishay"), disclaim any and all liability for any errors, inaccuracies or incompleteness contained herein or in any other disclosure relating to any product.

Vishay disclaims any and all liability arising out of the use or application of any product described herein or of any information provided herein to the maximum extent permitted by law. The product specifications do not expand or otherwise modify Vishay's terms and conditions of purchase, including but not limited to the warranty expressed therein, which apply to these products.

No license, express or implied, by estoppel or otherwise, to any intellectual property rights is granted by this document or by any conduct of Vishay.

The products shown herein are not designed for use in medical, life-saving, or life-sustaining applications unless otherwise expressly indicated. Customers using or selling Vishay products not expressly indicated for use in such applications do so entirely at their own risk and agree to fully indemnify Vishay for any damages arising or resulting from such use or sale. Please contact authorized Vishay personnel to obtain written terms and conditions regarding products designed for such applications.

Product names and markings noted herein may be trademarks of their respective owners.