

HIGH EFFICIENCY RED MAN3900A SERIES

PACKAGE DIMENSIONS

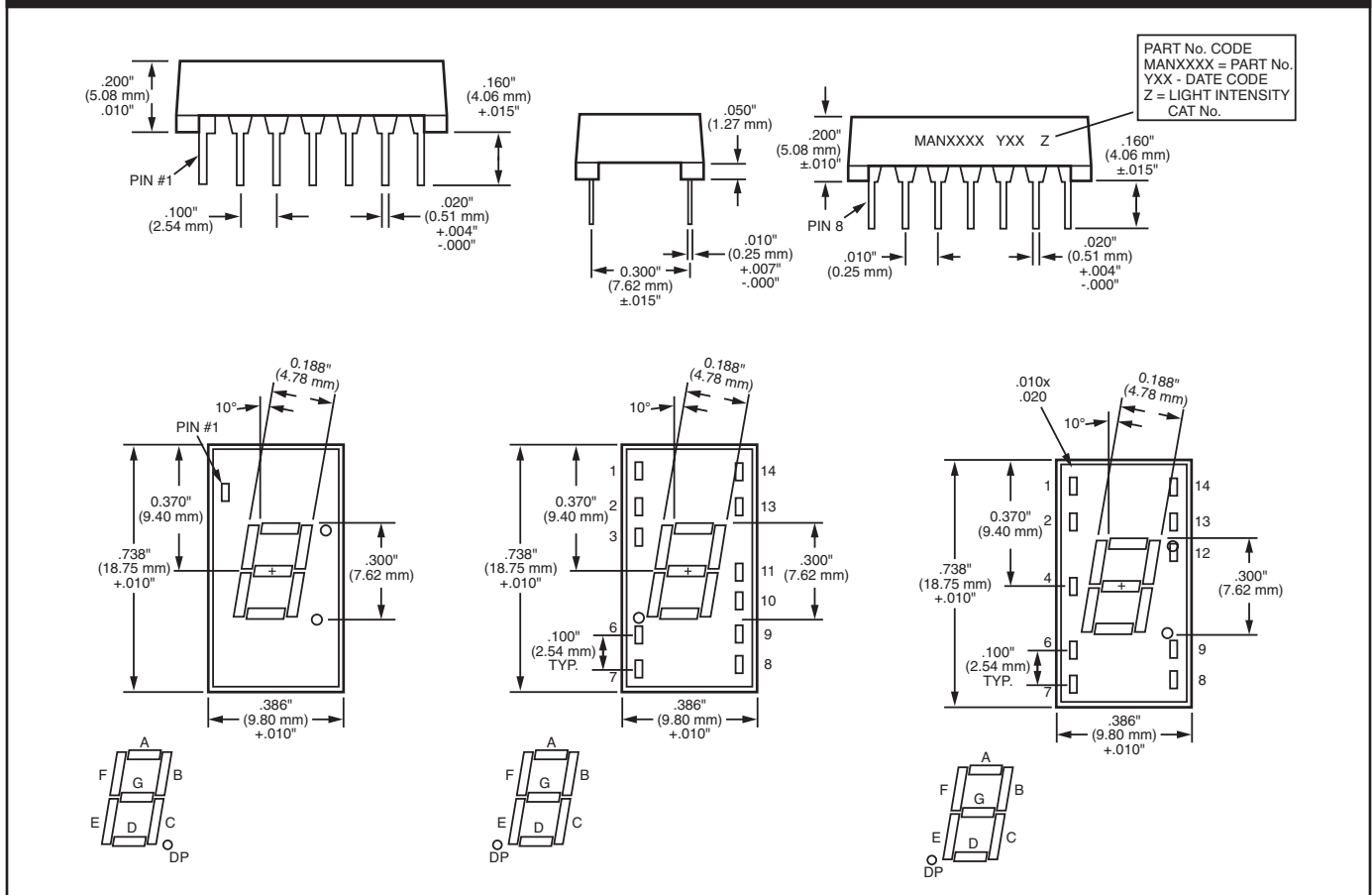

Description

The MAN3900A Series is a High Efficiency Red LED display. Standard units are also available in Red, Green, Orange and Yellow, with common anode right hand decimal, common anode left hand decimal and common cathode right hand decimal. They can be mounted in arrays with 0.400-inch (10.16 mm) center-to-center spacing. Units are constructed with Red face and segment color.

Features

- Common anode or common cathode models
- High Efficiency Red
- Fast switching — excellent for multiplexing
- Low power consumption
- Bold solid segments that are highly legible
- Solid state reliability — long operation life
- Impact resistant plastic construction
- Directly compatible with integrated circuits
- High brightness with high contrast
- Categorized for Luminous Intensity (See Note 6)

- Standard dual-in-line package configuration
- Wide angle viewing... 150°
- These devices have a Red face and Red segments

Applications

For industrial and consumer applications such as:

- Digital readout displays
- Instrument panels
- Point of sale equipment
- Calculators
- Digital clocks

HIGH EFFICIENCY RED MAN3900A SERIES

MODEL NUMBERS

Part Number	Color	Package	Description	Pin Out Specification
MAN3910A	High Efficiency Red	A	Common Anode; Right Hand Decimal	A
MAN3920A	High Efficiency Red	B	Common Anode; Left Hand Decimal	B
MAN3940A	High Efficiency Red	C	Common Cathode; Right Hand Decimal	C
MAN3980A	High Efficiency Red	D	Common Cathode; Left Hand Decimal	D

RECOMMENDED OPTICAL FILTERS

For optimum ON and OFF contrast, one of the following filters or equivalents should be used over the display:

Device Type	Filter
MAN3910A	Panelgraphic Scarlet 65 Homalite 100-1670
MAN3920A	
MAN3940A	
MAN3980A	

ELECTRO-OPTICAL CHARACTERISTICS (25°C Free Air Temperature Unless Otherwise Specified)

MAN3910A, MAN3920A, MAN3940A, MAN3980A	Min.	Typ.	Max.	Units	Test Conditions
Luminous Intensity, digit average (See Note 1 and 3)	450	1900		μcd	I _F = 10 mA
Peak emission wavelength		635		nm	
Spectral line half width		40		nm	
Forward voltage					
Segment			2.5	V	I _F = 20 mA
Decimal point			2.5	V	I _F = 20 mA
Dynamic resistance					
Segment		26		Ω	I _F = 20 mA
Decimal point		26		Ω	I _F = 20 mA
Capacitance					
Segment		35		pF	V = 0
Decimal point		35		pF	V = 0
Reverse current					
Segment			100	μA	V _R = 5.0V
Decimal point			100	μA	V _R = 5.0V

HIGH EFFICIENCY RED MAN3900A SERIES

ABSOLUTE MAXIMUM RATINGS	
MAN3910A, MAN3920A, MAN3940A, MAN3980A	
Power dissipation at 25°C ambient	600mW
Derate linearly from 50°C	-8.6mW/°C
Storage and operating temperature	-40°C to +85°C
Continuous forward current	
Total	240 mA
Per segment	30 mA
Decimal point	30 mA
Reverse voltage	
Per segment	6.0 V
Decimal point	6.0 V
Soldering time at 260°C (See Notes 4 and 5)	5 sec.

TYPICAL THERMAL CHARACTERISTICS	
HIGH EFFICIENCY RED	
Thermal resistance junction to free air ϕ_{JA}	160°C/W
Wavelength temperature coefficient (case temperature)	1.0Å/°C
Forward voltage temperature coefficient	-2.0 mV/°C

Notes:

1. The digit average Luminous Intensity is obtained by summing the Luminous Intensity of each segment and dividing by the total number of segments. Intensity will not vary more than $\pm 33.3\%$ between all segments within a digit.
2. The curve in Figure 3 is normalized to the brightness at 25°C to indicate the relative Luminous Intensity over the operating temperature range.
3. The decimal point is designed to have the same surface brightness as the segments, therefore, the Luminous Intensity of the decimal point is .3 times the Luminous Intensity of the segments, since the area of the decimal point is .3 times the area of the average segment.
4. Leads of the device immersed to 1/16 inch from the body. Maximum device surface temperature is 140°C.
5. For flux removal, Freon TF, Freon TE, Isoproponal or water may be used to their boiling points.
6. All displays are categorized for Luminous Intensity. The Intensity category is marked on each part as a suffix letter to the part number.

HIGH EFFICIENCY RED MAN3900A SERIES

ELECTRICAL CONNECTIONS				
Pin No.	ELECTRICAL CONNECTIONS			
	A MAN3910A	B MAN3920A	C MAN3940A	D MAN3980A
1	Cathode A	Cathode A	Anode F	Common Cathode
2	Cathode F	Cathode F	Anode G	Anode F
3	Common Anode	Common Anode	No Pin	Anode G
4	No Pin	No Pin	Common Cathode	Anode E
5	No Pin	No Pin	No Pin	Anode D
6	No Connection	Cathode D. P.	Anode E	Common Cathode
7	Cathode E	Cathode E	Anode D	Anode D.P.
8	Cathode D	Cathode D	Anode C	Anode C
9	Cathode D.P.	No Connection	Anode D.P.	Anode B
10	Cathode C	Cathode C	No Pin	Anode A
11	Cathode G	Cathode G	No Pin	
12	No Pin	No Pin	Common Cathode	
13	Cathode B	Cathode B	Anode B	
14	Common Anode	Common Anode	Anode A	

HIGH EFFICIENCY RED MAN3900A SERIES

TYPICAL CHARACTERISTIC CURVES

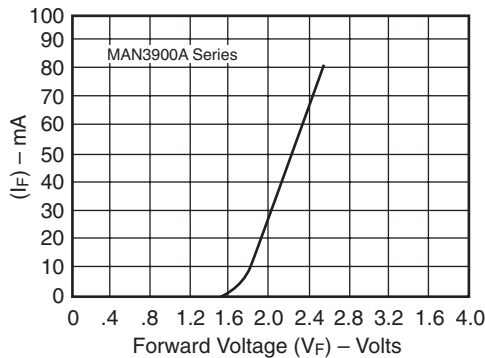

Fig. 1 Forward Current vs. Forward Voltage

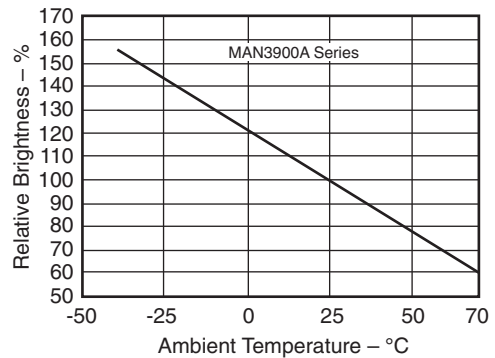

Fig. 2 Relative Luminous Intensity vs. Temperature

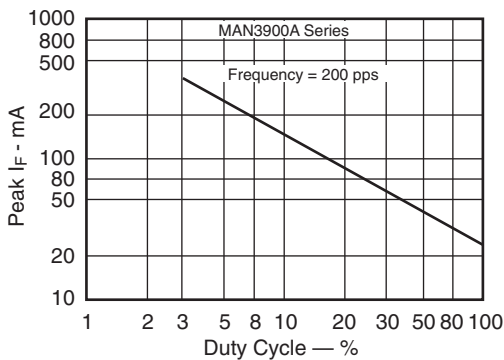

Fig. 3 Max Peak Current vs. Duty Cycle

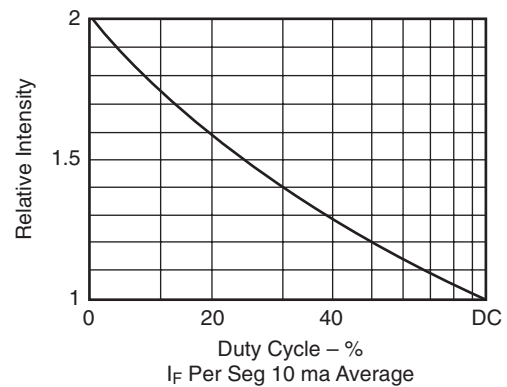

Fig. 4 Luminous Intensity vs. Duty Cycle

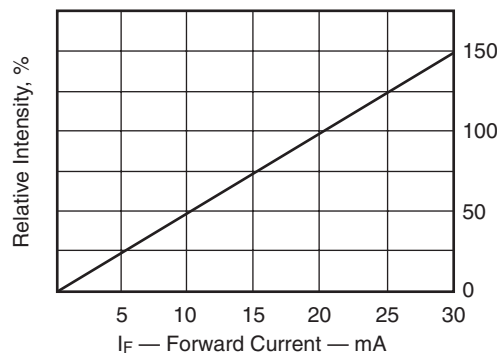

Fig. 5. Relative Luminous Intensity vs. Forward Current

HIGH EFFICIENCY RED MAN3900A SERIES

DISCLAIMER

FAIRCHILD SEMICONDUCTOR RESERVES THE RIGHT TO MAKE CHANGES WITHOUT FURTHER NOTICE TO ANY PRODUCTS HEREIN TO IMPROVE RELIABILITY, FUNCTION OR DESIGN. FAIRCHILD DOES NOT ASSUME ANY LIABILITY ARISING OUT OF THE APPLICATION OR USE OF ANY PRODUCT OR CIRCUIT DESCRIBED HEREIN; NEITHER DOES IT CONVEY ANY LICENSE UNDER ITS PATENT RIGHTS, NOR THE RIGHTS OF OTHERS.

LIFE SUPPORT POLICY

FAIRCHILD'S PRODUCTS ARE NOT AUTHORIZED FOR USE AS CRITICAL COMPONENTS IN LIFE SUPPORT DEVICES OR SYSTEMS WITHOUT THE EXPRESS WRITTEN APPROVAL OF THE PRESIDENT OF FAIRCHILD SEMICONDUCTOR CORPORATION. As used herein:

1. Life support devices or systems are devices or systems which, (a) are intended for surgical implant into the body, or (b) support or sustain life, and (c) whose failure to perform when properly used in accordance with instructions for use provided in the labeling, can be reasonably expected to result in a significant injury of the user.
2. A critical component in any component of a life support device or system whose failure to perform can be reasonably expected to cause the failure of the life support device or system, or to affect its safety or effectiveness.