

GBPC 15, 25, 35 SERIES

High Current 15, 25, 35 AMPS. Single Phase Glass Passivated Bridge Rectifiers



Features

- ✧ UL Recognized file # E-96005
- ✧ The plastic material used carries Underwriters Laboratory Flammability Recognition 94V-0
- ✧ Integrally molded heatsink provide very low thermal resistance for maximum heat dissipation
- ✧ Surge overload ratings from 300 amperes to 400 amperes
- ✧ Terminals solderable per MIL-STD-202, Method 208 (For wire type)
- ✧ Typical I_R less than 0.2 μ A
- ✧ High temperature soldering guaranteed: 260 °C / 10 seconds / .375", (9.5mm) lead lengths(For wire type)
- ✧ Isolated voltage from case to lead over 2500 volts

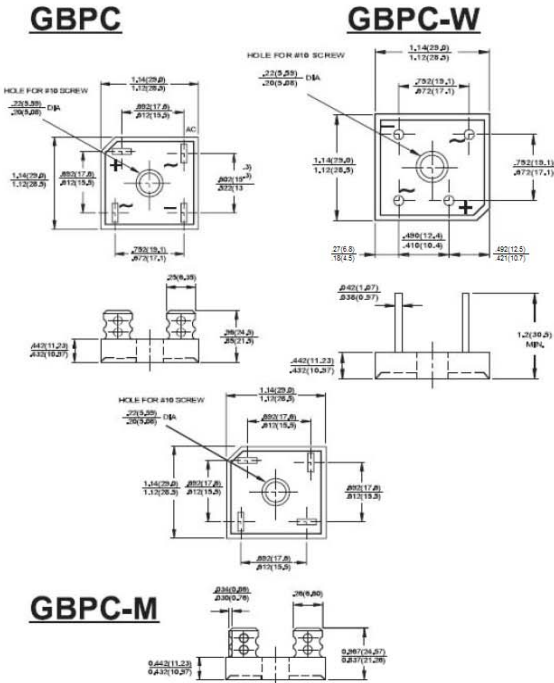

Dimensions in inches and (millimeters)

Maximum Ratings and Electrical Characteristics

Rating at 25 °C ambient temperature unless otherwise specified.
 Single phase, half wave, 60 Hz, resistive or inductive load.
 For capacitive load, derate current by 20%

Type Number	Symbol	-005	-01	-02	-04	-06	-08	-10	Units
Maximum Recurrent Peak Reverse Voltage	V_{RRM}	50	100	200	400	600	800	1000	V
Maximum RMS Voltage	V_{RMS}	35	70	140	280	420	560	700	V
Maximum DC Blocking Voltage	V_{DC}	50	100	200	400	600	800	1000	V
Maximum Average Forward Rectified Current @ $T_C = 55^\circ C$	$I_{(AV)}$				15.0	25.0	35.0		A
Peak Forward Surge Current, Single Sine-wave Superimposed on Rated Load (JEDEC method)	I_{FSM}				300	300	400		A
Maximum Instantaneous Forward Voltage Drop Per Element at Specified Current	V_F				1.1				V
Maximum DC Reverse Current at Rated DC Blocking Voltage Per Element	I_R				5				μ A
Typical Thermal Resistance (Note 1)	$R_{\theta JC}$				1.5				$^\circ C/W$
Operating and Storage Temperature Range	T_J, T_{STG}				-50 to +150				$^\circ C$

Notes: 1. Thermal Resistance from Junction to Case.
 2. Suffix "W" - Wire Lead Structure/"M" - Terminal Location Face to Face.

Version: D09

RATINGS AND CHARACTERISTIC CURVES
 GBPC15005 GBPC1510
 (GBPC25005 THRU GBPC2510)
 GBPC35005 GBPC3510

FIG.1- MAXIMUM FORWARD CURRENT DERATING CURVE

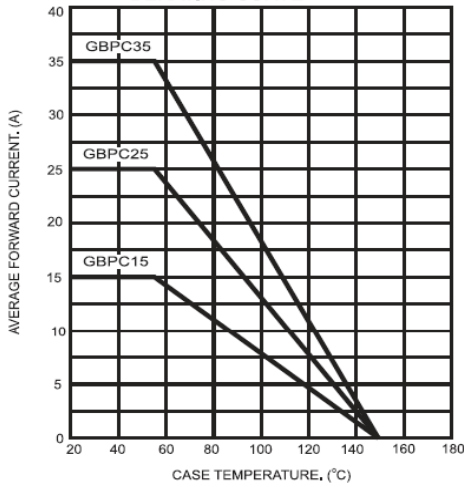

FIG.2- TYPICAL REVERSE CHARACTERISTICS PER BRIDGE ELEMENT

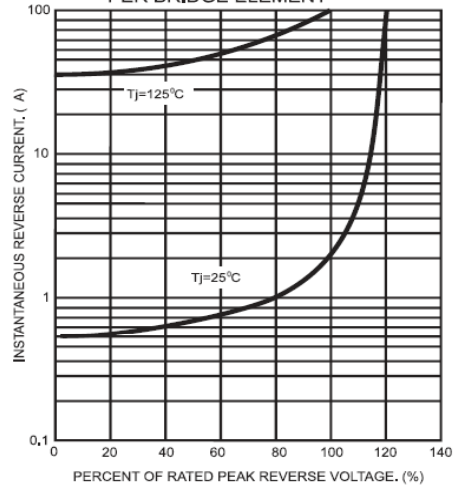

FIG.3- MAXIMUM NON-REPETITIVE FORWARD SURGE CURRENT PER BRIDGE ELEMENT

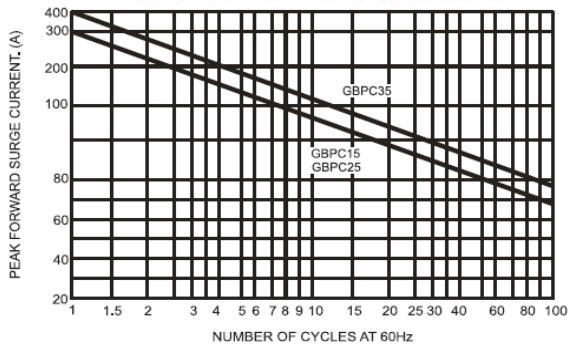

FIG.4- TYPICAL FORWARD CHARACTERISTICS PER BRIDGE ELEMENT

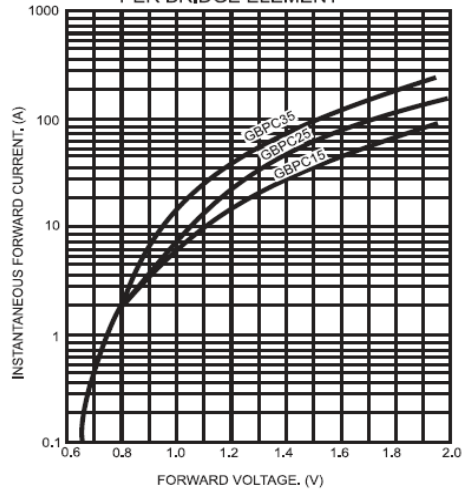

FIG.5- TYPICAL JUNCTION CAPACITANCE

