

LM63

$\pm 1^{\circ}\text{C}/\pm 3^{\circ}\text{C}$ Accurate Remote Diode Digital Temperature Sensor with Integrated Fan Control

General Description

The LM63 is a remote diode temperature sensor with integrated fan control. The LM63 accurately measures: (1) its own temperature and (2) the temperature of a diode-connected transistor, such as a 2N3904, or a thermal diode commonly found on Computer Processors, Graphics Processor Units (GPU) and other ASIC's. The LM63 remote temperature sensor's accuracy is factory trimmed for the series resistance and 1.0021 non-ideality of the Intel[®] 0.13 μm Pentium[®] 4 and Mobile Pentium 4 Processor-M thermal diode. The LM63 has an offset register to correct for errors caused by different non-ideality factors of other thermal diodes. For the latest information contact hardware.monitor.team@nsc.com.

The LM63 also features an integrated, pulse-width-modulated (PWM), open-drain fan control output. Fan speed is a combination of the remote temperature reading, the lookup table and the register settings. The 8-step Lookup Table enables the user to program a non-linear fan speed vs. temperature transfer function often used to quiet acoustic fan noise.

Features

- Accurately senses diode-connected 2N3904 transistors or thermal diodes on-board large processors or ASIC's
- Accurately senses its own temperature
- Factory trimmed for Intel Pentium 4 and Mobile Pentium 4 Processor-M thermal diodes
- Integrated PWM fan speed control output
- Acoustic fan noise reduction with User-programmable 8-step Lookup Table
- Multi-function, user-selectable pin for either $\overline{\text{ALERT}}$ output, or Tachometer input, functions
- Tachometer input for measuring fan RPM
- Offset register can adjust for a variety of thermal diodes

- 10 bit plus sign remote diode temperature data format, with 0.125°C resolution
- SMBus 2.0 compatible interface, supports TIMEOUT
- LM86-compatible pinout
- LM86-compatible register set
- 8-pin SOIC package

Key Specifications

- Remote Diode Temp Accuracy (with quantization error)

Ambient Temp	Diode Temp	$I_{\text{PWML Max}}$	Version	Max Error
30 to 50°C	60 to 100°C	5 mA	LM63C	$\pm 1.0^{\circ}\text{C}$
30 to 50°C	60 to 100°C	5 mA	LM63D	$\pm 3.0^{\circ}\text{C}$
0 to 85°C	25 to 125°C	8 mA	All	$\pm 3.0^{\circ}\text{C}$
- Local Temp Accuracy (includes quantization error)

Ambient Temp	Max Error
25°C to 125°C	$\pm 3.0^{\circ}\text{C}$
- Supply Voltage 3.0 V to 3.6 V
- Supply Current 1.3 mA (typ)

Applications

- Computer Processor Thermal Management (Laptop, Desktop, Workstations, Servers)
- Graphics Processor Thermal Management
- Electronic Test Equipment
- Projectors
- Office Equipment
- Industrial Controls

Connection Diagram

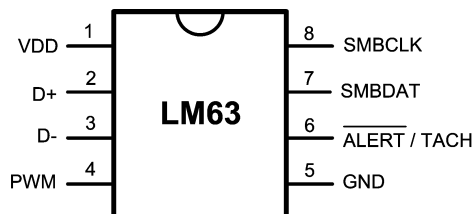

20057001

 Intel[®] and Pentium[®] are registered trademarks of Intel Corporation.

Pin Descriptions

Pin	Name	Input/Output	Function and Connection
1	V _{DD}	Power Supply Input	Connect to a low-noise +3.3 ± 0.3 VDC power supply, and bypass to GND with a 0.1 μF ceramic capacitor in parallel with a 100 pF ceramic capacitor. A bulk capacitance of 10 μF needs to be in the vicinity of the LM63's V _{DD} pin.
2	D+	Analog Input	Connect to the anode (positive side) of the remote diode. A 2.2 nF ceramic capacitor must be connected between pins 2 and 3.
3	D-	Analog Input	Connect to the cathode (negative side) of the remote diode. A 2.2 nF ceramic capacitor must be connected between pins 2 and 3.
4	PWM	Open-Drain Digital Output	Open-Drain Digital Output. Connect to fan drive circuitry. The power-on default for this pin is low (pin 4 pulled to ground).
5	GND	Ground	This is the analog and digital ground return.
6	$\overline{\text{ALERT}}/\text{TACH}$	Digital I/O	Depending on how the LM63 is programmed, this pin is either an open-drain $\overline{\text{ALERT}}$ output or a tachometer input for measuring fan speed. The power-on default for this pin is the ALERT function.
7	SMBDAT	Digital Input/ Open-Drain Output	This is the bi-directional SMBus data line.
8	SMBCLK	Digital Input	Digital Input. This is the SMBus clock input.

Simplified Block Diagram

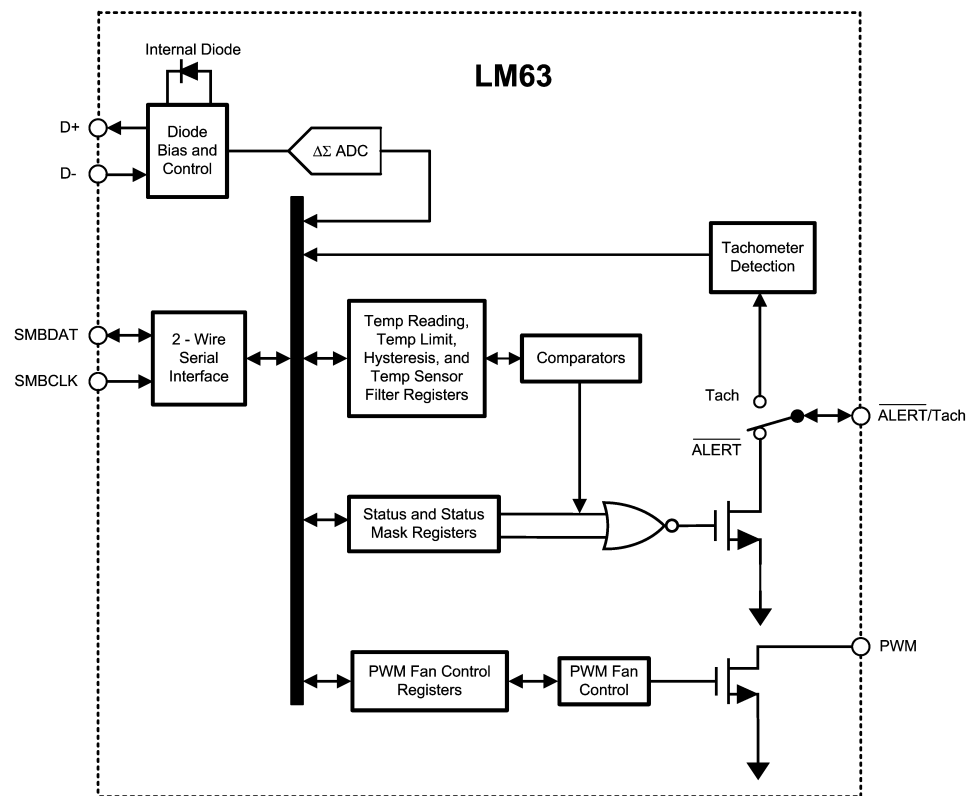

Typical Application

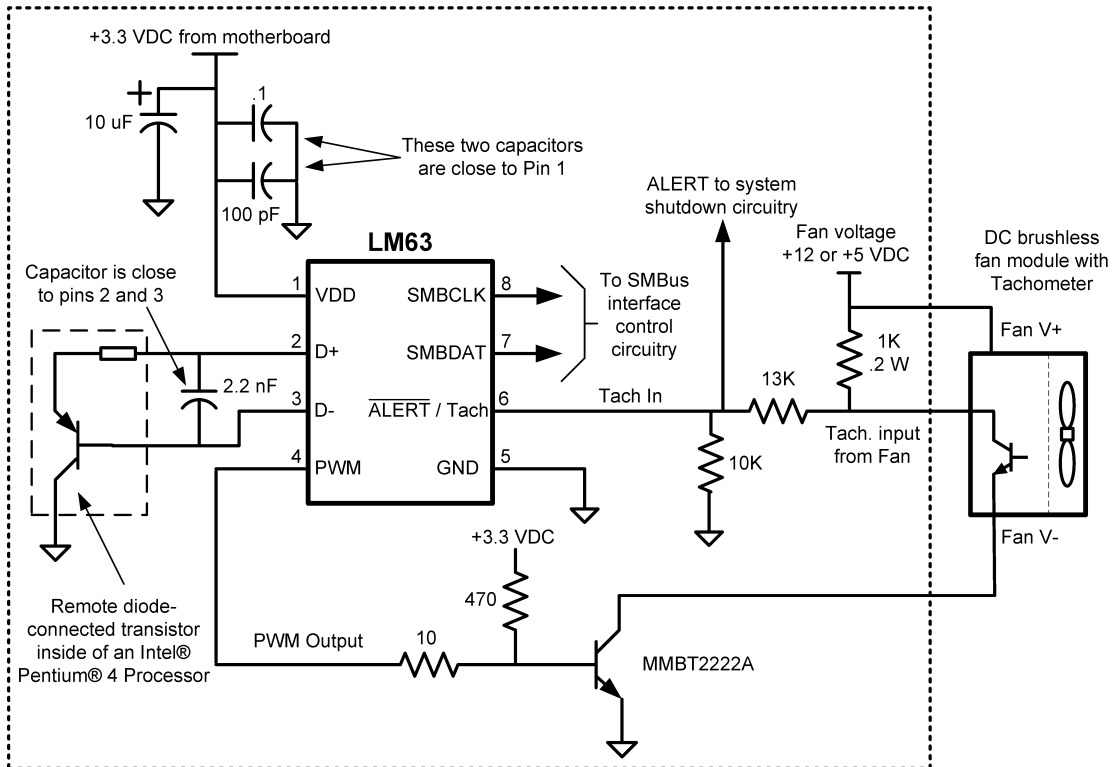

20057003

Ordering Information

Part Description	Top Mark	Order Number	Transport Media
LM63C ($\pm 1^\circ\text{C}$) 8-pin SOIC	LM63CIMA	LM63CIMAX	2500 Units in Tape and Reel
LM63C ($\pm 1^\circ\text{C}$) 8-pin SOIC	LM63CIMA	LM63CIMA	95 Units in Rail
LM63D ($\pm 3^\circ\text{C}$) 8-pin SOIC	LM63DIMA	LM63DIMAX	2500 Units in Tape and Reel
LM63D ($\pm 3^\circ\text{C}$) 8-pin SOIC	LM63DIMA	LM63DIMA	95 Units in Rail
LM63 Evaluation Board With Software and User's Guide	N/A	LM63EVAL	Packaged

Absolute Maximum Ratings (Notes 1,

2)

Supply Voltage, V_{DD}	-0.3 V to 6.0 V
Voltage on SMBDAT, SMBCLK, $\overline{\text{ALERT}}$ /Tach, PWM Pins	-0.5 V to 6.0 V
Voltage on Other Pins	-0.3 V to ($V_{DD} + 0.3$ V)
Input Current, D- Pin	± 1 mA
Input Current at All Other Pins (Note 3)	5 mA
Package Input Current (Note 3)	30 mA
Package Power Dissipation SMBDAT, $\overline{\text{ALERT}}$, PWM pins	(Note 5)
Output Sink Current	10 mA
Storage Temperature	-65°C to +150°C

ESD Susceptibility (Note 4)

Human Body Model	2000 V
Machine Model	200 V

Soldering Information, Lead Temperature

SOIC-8 Package (Note 6)	
Vapor Phase (60 seconds)	215°C
Infrared (15 seconds)	220°C

Operating Ratings (Notes 1, 2)

Specified Temperature Range	$T_{MIN} \leq T_A \leq T_{MAX}$
LM63CIM, LM63DIM	$0^\circ\text{C} \leq T_A \leq +85^\circ\text{C}$
Remote Diode Temperature Range	$0^\circ\text{C} \leq T_A \leq +125^\circ\text{C}$
Supply Voltage Range (V_{DD})	+3.0 V to +3.6 V

DC Electrical Characteristics

TEMPERATURE-TO-DIGITAL CONVERTER CHARACTERISTICS The following specifications apply for $V_{DD} = 3.0$ VDC to 3.6 VDC, and all analog source impedance $R_S = 50\Omega$ unless otherwise specified in the conditions. **Boldface limits apply for $T_A = T_{MIN}$ to T_{MAX}** ; all other limits $T_A = +25^\circ\text{C}$.

Parameter	Conditions		Version	Typical (Note 7)	Limits (Note 8)	Units (Limits)
Temperature Error Using the Remote Thermal Diode of an Intel Pentium 4 or Mobile Pentium 4 Processor-M with typical non-ideality of 1.0021. For other processors e-mail hardware.monitor.team@nsc.com to obtain the latest data.	$T_A = +30$ to $+50^\circ\text{C}$ $I_{PWML} \leq 5$ mA	$T_D = +60$ to $+100^\circ\text{C}$ $T_D =$ Remote Diode Junction Temperature	LM63C		± 1	$^\circ\text{C}$ (max)
			LM63D		± 3	$^\circ\text{C}$ (max)
	$T_A = +0$ to $+85^\circ\text{C}$ $I_{PWML} \leq 8$ mA	$T_D = +25$ to $+125^\circ\text{C}$	All		± 3	$^\circ\text{C}$ (max)
Temperature Error Using the Local Diode	$T_A = +25$ to $+125^\circ\text{C}$ (Note 10)		All	± 1	± 3	$^\circ\text{C}$ (max)
Remote Diode Resolution			All	11		Bits
				0.125		$^\circ\text{C}$
Local Diode Resolution			All	8		Bits
				1		$^\circ\text{C}$
Conversion Time, All Temperatures	Fastest Setting		All	31.25	34.4	ms (max)
D- Source Voltage			All	0.7		V
Diode Source Current	$(V_{D+} - V_{D-}) = +0.65$ V; High Current		All	160	315	μA (max)
					110	μA (min)
	Low Current	All	13	20	μA (max)	
					7	μA (min)

Operating Electrical Characteristics

Parameter	Conditions			Typ (Note 7)	Limits (Note 8)	Units
$\overline{\text{ALERT}}$ and PWM Output Saturation Voltage	$\overline{\text{ALERT}}$		PWM			
	I_{OUT}	4 mA	5 mA		0.4	V (max)
	I_{OUT}	6 mA			0.55	
Power-On-Reset Threshold Voltage					2.4	V (max)
					1.8	V (min)
Supply Current (Note 9)	SMBus Inactive, 16 Hz Conversion Rate			1.1	2.0	mA (max)
	STANDBY Mode			300		μA

AC Electrical Characteristics

The following specifications apply for $V_{DD} = 3.0$ VDC to 3.6 VDC, and all analog source impedance $R_S = 50\Omega$ unless otherwise specified in the conditions. **Boldface limits apply for $T_A = T_{MIN}$ to T_{MAX}** ; all other limits $T_A = +25^\circ\text{C}$.

Symbol	Parameter	Conditions	Typical (Note 7)	Limits (Note 8)	Units (Limit)
TACHOMETER ACCURACY					
	Fan Control Accuracy			± 10	% (max)
	Fan Full-Scale Count			65535	(max)
	Fan Counter Clock Frequency		90		kHz
	Fan Count Update Frequency		1.0		Hz
FAN PWM OUTPUT					
	Frequency Accuracy			± 10	% (max)

Digital Electrical Characteristics

Symbol	Parameter	Conditions	Typical (Note 7)	Limits (Note 8)	Units (Limit)
V_{IH}	Logical High Input Voltage			2.1	V (min)
V_{IL}	Logical Low Input Voltage			0.8	V (max)
I_{IH}	Logical High Input Current	$V_{IN} = V_{DD}$	0.005	+10	μA (max)
I_{IL}	Logical Low Input Current	$V_{IN} = \text{GND}$	-0.005	-10	μA (max)
C_{IN}	Digital Input Capacitance		20		pF

SMBus Logical Electrical Characteristics

The following specifications apply for $V_{DD} = 3.0$ VDC to 3.6 VDC, and all analog source impedance $R_S = 50\Omega$ unless otherwise specified in the conditions. **Boldface limits apply for $T_A = T_{MIN}$ to T_{MAX}** ; all other limits $T_A = +25^\circ\text{C}$.

Symbol	Parameter	Conditions	Typical (Note 7)	Limits (Note 8)	Units (Limit)
SMBDAT OPEN-DRAIN OUTPUT					
V_{OL}	Logic Low Level Output Voltage	$I_{OL} = 4$ mA		0.4	V (max)
I_{OH}	High Level Output Current	$V_{OUT} = V_{DD}$	0.03	10	μA (max)
SMBDAT, SMBCLK INPUTS					
V_{IH}	Logical High Input Voltage			2.1	V (min)
V_{IL}	Logical Low Input Voltage			0.8	V (max)
V_{HYST}	Logic Input Hysteresis Voltage		320		mV

SMBus Digital Switching Characteristics

Unless otherwise noted, these specifications apply for $V_{DD} = +3.0 \text{ VDC}$ to $+3.6 \text{ VDC}$, C_L (load capacitance) on output lines = 80 pF. **Boldface limits apply for $T_A = T_J$; $T_{MIN} \leq T_A \leq T_{MAX}$** ; all other limits $T_A = T_J = +25^\circ\text{C}$, unless otherwise noted. The switching characteristics of the LM63 fully meet or exceed the published specifications of the SMBus version 2.0. The following parameters are the timing relationships between SMBCLK and SMBDAT signals related to the LM63. They adhere to but are not necessarily the same as the SMBus bus specifications.

Symbol	Parameter	Conditions	Limits (Note 8)	Units (Limit)
f_{SMB}	SMBus Clock Frequency		10 100	kHz (min) kHz (max)
t_{LOW}	SMBus Clock Low Time	From $V_{IN(0) \text{ max}}$ to $V_{IN(0) \text{ max}}$	4.7	μs (min)
t_{HIGH}	SMBus Clock High Time	From $V_{IN(1) \text{ min}}$ to $V_{IN(1) \text{ min}}$	4.0 50	μs (min) μs (max)
t_R	SMBus Rise Time	(Note 11)	1	μs (max)
t_F	SMBus Fall Time	(Note 12)	0.3	μs (max)
t_{OF}	Output Fall Time	$C_L = 400 \text{ pF}$, $I_O = 3 \text{ mA}$	250	ns (max)
$t_{TIMEOUT}$	SMBData and SMBCLK Time Low for Reset of Serial Interface See (Note 13)		25 35	ms (min) ms (max)
$t_{SU:DAT}$	Data In Setup Time to SMBCLK High		250	ns (min)
$t_{HD:DAT}$	Data Out Hold Time after SMBCLK Low		300 930	ns (min) ns (max)
$t_{HD:STA}$	Hold Time after (Repeated) Start Condition. After this period the first clock is generated.		4.0	μs (min)
$t_{SU:STO}$	Stop Condition SMBCLK High to SMBDAT Low (Stop Condition Setup)		100	ns (min)
$t_{SU:STA}$	SMBus Repeated Start-Condition Setup Time, SMBCLK High to SMBDAT Low		4.7	μs (min)
t_{BUF}	SMBus Free Time between Stop and Start Conditions		4.7	μs (min)

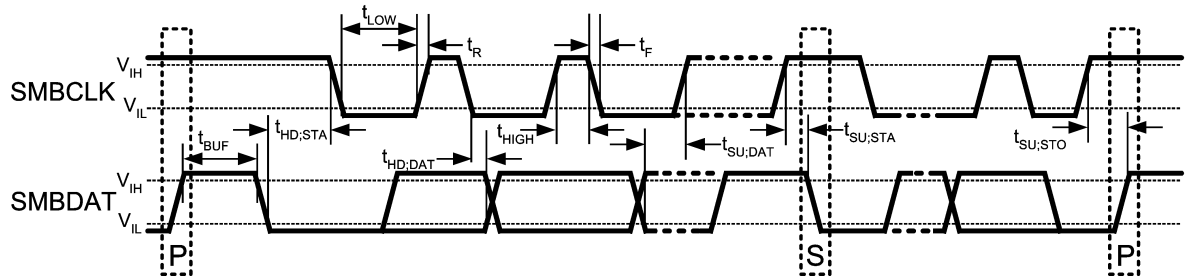

SMBus Timing Diagram for SMBCLK and SMBDAT Signals

20057004

Note 1: Absolute Maximum Ratings indicate limits beyond which damage to the device may occur. Operating Ratings indicate conditions for which the device is functional, but do not guarantee performance limits. For guaranteed specifications and test conditions, see the Electrical Characteristics. The guaranteed specifications apply only for the test conditions listed. Some performance characteristics may degrade when the device is not operated under the listed test conditions.

Note 2: All voltages are measured with respect to GND, unless otherwise noted.

Note 3: When the input voltage (V_{IN}) at any pin exceeds the power supplies ($V_{IN} < GND$ or $V_{IN} > V+$), the current at that pin should be limited to 5 mA. Parasitic components and/or ESD protection circuitry are shown below for the LM63's pins. The nominal breakdown voltage of D3 is 6.5 V. Care should be taken not to forward bias the parasitic diode, D1, present on pins D+ and D-. Doing so by more than 50 mV may corrupt temperature measurements. An "X" means it exists in the circuit.

Pin Name	PIN #	D1	D2	D3	D4	D5	D6	R1	SNP	ESD CLAMP
V_{DD}	1			X						X
D+	2	X	X			X	X	X		X
D-	3	X	X		X	X	X			X
PWM	4		X				X	X	X	
ALERT/Tach	6		X				X	X	X	
SMBDAT	7		X				X	X	X	
SMBCLK	8		X						X	

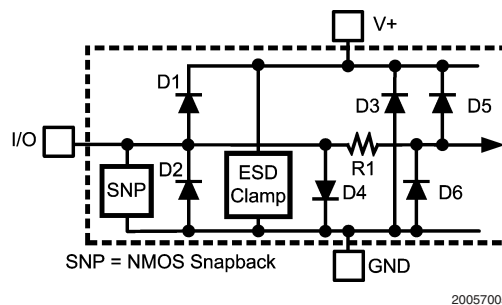

FIGURE 1. ESD Protection Input Structure

Note 4: Human body model, 100 pF discharged through a 1.5 k Ω resistor. Machine model, 200 pF discharged directly into each pin. See Figure 1 above for the ESD Protection Input Structure.

Note 5: Thermal resistance junction-to-ambient when attached to a printed circuit board with 2 oz. foil is 168°C/W.

Note 6: See the URL "http://www.national.com/packaging/" for other recommendations and methods of soldering surface mount devices.

Note 7: "Typicals" are at $T_A = 25^\circ\text{C}$ and represent most likely parametric norm. They are to be used as general reference values not for critical design calculations.

Note 8: Limits are guaranteed to National's AOQL (Average Outgoing Quality Level).

Note 9: The supply current will not increase substantially with an SMBus transaction.

Note 10: Local temperature accuracy does not include the effects of self-heating. The rise in temperature due to self-heating is the product of the internal power dissipation of the LM63 and the thermal resistance. See (Note 5) for the thermal resistance to be used in the self-heating calculation.

Note 11: The output rise time is measured from ($V_{IL\ max} - 0.15\ \text{V}$) to ($V_{IH\ min} + 0.15\ \text{V}$).

Note 12: The output fall time is measured from ($V_{IH\ min} + 0.15\ \text{V}$) to ($V_{IL\ min} - 0.15\ \text{V}$).

Note 13: Holding the SMBData and/or SMBCLK lines Low for a time interval greater than $t_{TIMEOUT}$ will reset the LM63's SMBus state machine, therefore setting SMBDAT and SMBCLK pins to a high impedance state.

1.0 Functional Description

The LM63 Remote Diode Temperature Sensor with Integrated Fan Control incorporates a ΔV_{BE} -based temperature sensor using a Local or Remote diode and a 10-bit plus sign $\Delta\Sigma$ ADC (Delta-Sigma Analog-to-Digital Converter). The pulse-width modulated (PWM) open-drain output, with a pull-up resistor, can drive a switching transistor to modulate the fan. When the ALERT/Tach is programmed to the Tach mode the LM63 can measure the fan speed on the pulses from the fan's tachometer output. When the ALERT/Tach pin is programmed to the ALERT mode the ALERT open-drain output will be pulled low when the measured temperature exceeds certain programmed limits when enabled. Details are contained in the sections below.

The LM63's two-wire interface is compatible with the SMBus Specification 2.0. For more information the reader is directed to www.smbus.org.

In the LM63 digital comparators are used to compare the measured Local Temperature (LT) to the Local High Setpoint user-programmable temperature limit register. The measured Remote Temperature (RT) is digitally compared to the Remote High Setpoint (RHS), the Remote Low Setpoint (RLS), and the Remote T_{CRIT} Setpoint (RCS) user-programmable temperature limits. An ALERT output will occur when the measured temperature is: (1) higher than either the High Setpoint or the T_{CRIT} Setpoint, or (2) lower than the Low Setpoint. The ALERT Mask register allows the user to prevent the generation of these ALERT outputs.

The temperature hysteresis is set by the value placed in the Hysteresis Register (TH).

The LM63 may be placed in a low power Standby mode by setting the Standby bit found in the Configuration Register. In the Standby mode continuous conversions are stopped. In

1.0 Functional Description (Continued)

Standby mode the user may choose to allow the PWM output signal to continue, or not, by programming the PWM Disable in Standby bit in the Configuration Register.

The Local Temperature reading and setpoint data registers are 8-bits wide. The format of the 11-bit remote temperature data is a 16-bit left justified word. Two 8-bit registers, high and low bytes, are provided for each setpoint as well as the temperature reading. Two Remote Temperature Offset (RTO) Registers: High Byte and Low Byte (RTOHB and RTOLB) may be used to correct the temperature readings by adding or subtracting a fixed value based on a different non-ideality factor of the thermal diode if different from the 0.13 micron Intel Pentium 4 or Mobile Pentium 4 Processor-M processor's thermal diode. See Section 4.1 Thermal Diode Non-Ideality.

1.1 CONVERSION SEQUENCE

The LM63 takes approximately 31.25 ms to convert the Local Temperature (LT), Remote Temperature (RT), and to update all of its registers. The Conversion Rate may be modified using the Conversion Rate Register. When the conversion rate is modified a delay is inserted between conversions, the actual conversion time remains at 31.25 ms. Different Conversion Rates will cause the LM63 to draw different amounts of supply current as shown in Figure 2.

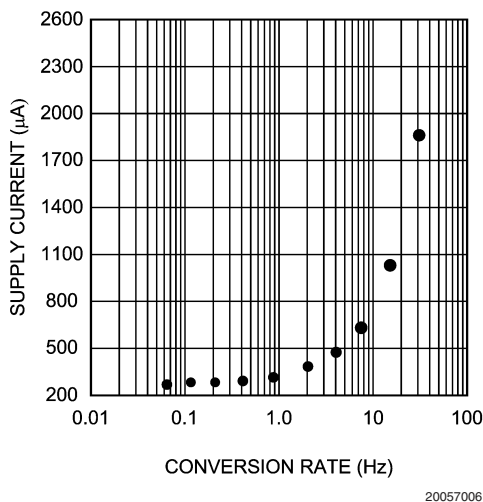

FIGURE 2. Supply Current vs Conversion Rate

1.2 THE $\overline{\text{ALERT}}$ /TACH PIN AS $\overline{\text{ALERT}}$ OUTPUT

The $\overline{\text{ALERT}}$ /Tach pin is a multi-use pin. In this section we will address the $\overline{\text{ALERT}}$ active-low open-drain output function. When the $\overline{\text{ALERT}}$ /Tach Select bit is written as a zero in the Configuration Register the $\overline{\text{ALERT}}$ output is selected. Also, when the $\overline{\text{ALERT}}$ Mask bit in the Configuration register is written as zero the $\overline{\text{ALERT}}$ interrupts are enabled.

The LM63's $\overline{\text{ALERT}}$ pin is versatile and can produce three different methods of use to best serve the system designer: (1) as a temperature comparator (2) as a temperature-based interrupt flag, and (3) as part of an SMBus $\overline{\text{ALERT}}$ System. The three methods of use are further described below. The $\overline{\text{ALERT}}$ and interrupt methods are different only in how the user interacts with the LM63.

The remote temperature (RT) reading is associated with a T_CRIT Setpoint Register, and both local and remote temperature (LT and RT) readings are associated with a HIGH setpoint register (LHS and RHS). The RT is also associated with a LOW setpoint register (RLS). At the end of every temperature reading a digital comparison determines whether that reading is above its HIGH or T_CRIT setpoint or below its LOW setpoint. If so, the corresponding bit in the $\overline{\text{ALERT}}$ Status Register is set. If the $\overline{\text{ALERT}}$ mask bit is low, any bit set in the $\overline{\text{ALERT}}$ Status Register, with the exception of Busy or Open, will cause the $\overline{\text{ALERT}}$ output to be pulled low. Any temperature conversion that is out of the limits defined in the temperature setpoint registers will trigger an $\overline{\text{ALERT}}$. Additionally, the $\overline{\text{ALERT}}$ Mask Bit must be cleared to trigger an $\overline{\text{ALERT}}$ in all modes.

The three different $\overline{\text{ALERT}}$ modes will be discussed in the following sections.

1.2.1 $\overline{\text{ALERT}}$ Output as a Temperature Comparator

When the LM63 is used in a system in which does not require temperature-based interrupts, the $\overline{\text{ALERT}}$ output could be used as a temperature comparator. In this mode, once the condition that triggered the $\overline{\text{ALERT}}$ to go low is no longer present, the $\overline{\text{ALERT}}$ is negated (Figure 3). For example, if the $\overline{\text{ALERT}}$ output was activated by the comparison of $\text{LT} > \text{LHS}$, when this condition is no longer true, the $\overline{\text{ALERT}}$ will return HIGH. This mode allows operation without software intervention, once all registers are configured during set-up. In order for the $\overline{\text{ALERT}}$ to be used as a temperature comparator, the Comparator Mode bit in the Remote Diode Temperature Filter and Comparator Mode Register must be asserted. This is not the power-on default state.

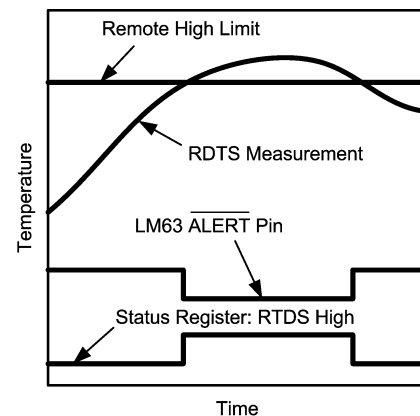

FIGURE 3. $\overline{\text{ALERT}}$ Output as Temperature Comparator Response Diagram

1.2.2 $\overline{\text{ALERT}}$ Output as an Interrupt

The LM63's $\overline{\text{ALERT}}$ output can be implemented as a simple interrupt signal when it is used to trigger an interrupt service routine. In such systems it is desirable for the interrupt flag to repeatedly trigger during or before the interrupt service routine has been completed. Under this method of operation, during the read of the $\overline{\text{ALERT}}$ Status Register the LM63 will set the $\overline{\text{ALERT}}$ Mask bit in the Configuration Register if any bit in the $\overline{\text{ALERT}}$ Status Register is set, with the exception of Busy and Open. This prevents further $\overline{\text{ALERT}}$ triggering until the master has reset the $\overline{\text{ALERT}}$ Mask bit, at the end of the interrupt service routine. The $\overline{\text{ALERT}}$ Status Register bits are

1.0 Functional Description (Continued)

cleared only upon a read command from the master (see *Figure 4*) and will be re-asserted at the end of the next conversion if the triggering condition(s) persist(s). In order for the $\overline{\text{ALERT}}$ to be used as a dedicated interrupt signal, the Comparator Mode bit in the Remote Diode Temperature Filter and Comparator Mode Register must be set low. This is the power-on default state. The following sequence describes the response of a system that uses the $\overline{\text{ALERT}}$ output pin as an interrupt flag:

1. Master senses $\overline{\text{ALERT}}$ low.
2. Master reads the LM63 ALERT Status Register to determine what caused the ALERT.
3. LM63 clears ALERT Status Register, resets the $\overline{\text{ALERT}}$ HIGH and sets the ALERT Mask bit in the Configuration Register.
4. Master attends to conditions that caused the $\overline{\text{ALERT}}$ to be triggered. The fan is started, setpoint limits are adjusted, etc.
5. Master resets the ALERT Mask bit in the Configuration Register.

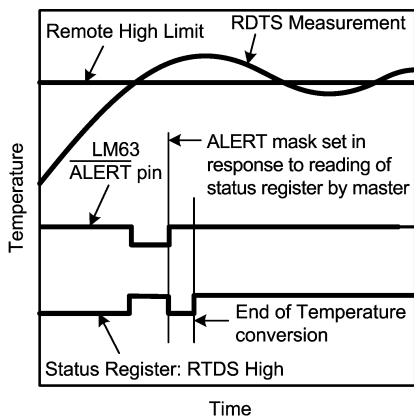

20057008

FIGURE 4. $\overline{\text{ALERT}}$ Output as an Interrupt Temperature Response Diagram

1.2.3 $\overline{\text{ALERT}}$ Output as an SMBus ALERT

An SMBus alert line is created when the $\overline{\text{ALERT}}$ output is connected to: (1) one or more $\overline{\text{ALERT}}$ outputs of other SMBus compatible devices, and (2) to a master. Under this implementation, the LM63's $\overline{\text{ALERT}}$ should be operated using the ARA (Alert Response Address) protocol. The SMBus 2.0 ARA protocol, defined in the SMBus specification 2.0, is a procedure designed to assist the master in determining which part generated an interrupt and to service that interrupt.

The SMBus alert line is connected to the open-drain ports of all devices on the bus, thereby AND'ing them together. The ARA method allows the SMBus master, with one command, to identify which part is pulling the SMBus alert line LOW. It also prevents the part from pulling the line LOW again for the same triggering condition. When an ARA command is received by all devices on the bus, the devices pulling the SMBus alert line LOW: (1) send their address to the master and (2) release the SMBus alert line after acknowledgement of their address.

The SMBus Specifications 1.1 and 2.0 state that in response to an ARA (Alert Response Address) "after acknowledging the slave address the device must disengage its ALERT pulldown". Furthermore, "if the host still sees ALERT low when the message transfer is complete, it knows to read the ARA again." This SMBus "disengaging ALERT requirement prevents locking up the SMBus alert line. Competitive parts may address the "disengaging of ALERT" differently than the LM63 or not at all. SMBus systems that implement the ARA protocol as suggested for the LM63 will be fully compatible with all competitive parts.

The LM63 fulfills "disengaging of ALERT" by setting the ALERT Mask Bit in the Configuration Register after sending out its address in response to an ARA and releasing the $\overline{\text{ALERT}}$ output pin. Once the ALERT Mask bit is activated, the $\overline{\text{ALERT}}$ output pin will be disabled until enabled by software. In order to enable the ALERT the master must read the ALERT Status Register, during the interrupt service routine and then reset the ALERT Mask bit in the Configuration Register to 0 at the end of the interrupt service routine.

The following sequence describes the ARA response protocol.

1. Master senses SMBus alert line low
2. Master sends a START followed by the Alert Response Address (ARA) with a Read Command.
3. Alerting Device(s) send ACK.
4. Alerting Device(s) send their address. While transmitting their address, alerting devices sense whether their address has been transmitted correctly. (The LM63 will reset its ALERT output and set the ALERT Mask bit once its complete address has been transmitted successfully.)
5. Master/slave NoACK
6. Master sends STOP
7. Master attends to conditions that caused the ALERT to be triggered. The ALERT Status Register is read and fan started, setpoints adjusted, etc.
8. Master resets the ALERT Mask bit in the Configuration Register.

The ARA, 000 1100, is a general call address. No device should ever be assigned to this address.

The ALERT Configuration bit in the Remote Diode Temperature Filter and Comparator Mode Register must be set low in order for the LM63 to respond to the ARA command.

The $\overline{\text{ALERT}}$ output can be disabled by setting the ALERT Mask bit in the Configuration Register. The power-on default is to have the ALERT Mask bit and the ALERT Configuration bit low.

1.0 Functional Description (Continued)

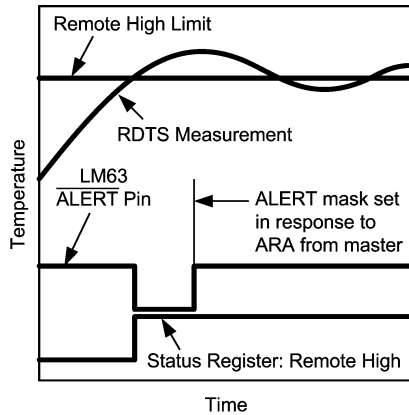

20057009

FIGURE 5. $\overline{\text{ALERT}}$ Output as an SMBus ALERT Temperature Response Diagram

1.3 SMBus INTERFACE

Since the LM63 operates as a slave on the SMBus the SMBCLK line is an input and the SMBDAT line is bi-directional. The LM63 never drives the SMBCLK line and it does not support clock stretching. According to SMBus specifications, the LM63 has a 7-bit slave address. All bits, A6 through A0, are internally programmed and cannot be changed by software or hardware.

The complete slave address is:

A6	A5	A4	A3	A2	A1	A0
1	0	0	1	1	0	0

1.4 POWER-ON RESET (POR) DEFAULT STATES

For information on the POR default states see Section 2.2 LM63 Register Map in Functional Order.

1.5 TEMPERATURE DATA FORMAT

Temperature data can only be read from the Local and Remote Temperature registers. The High, Low and T_CRIT setpoint registers are Read/Write.

Remote temperature data is represented by an 11-bit, two's complement word with a Least Significant Bit (LSB) equal to 0.125°C. The data format is a left justified 16-bit word available in two 8-bit registers:

Temperature	Digital Output	
	Binary	Hex
+125°C	0111 1101 0000 0000	7D00
+25°C	0001 1001 0000 0000	1900
+1°C	0000 0001 0000 0000	0100
+0.125°C	0000 0000 0010 0000	0020
0°C	0000 0000 0000 0000	0000
-0.125°C	1111 1111 1110 0000	FFE0
-1°C	1111 1111 0000 0000	FF00
-25°C	1110 0111 0000 0000	E700
-55°C	1100 1001 0000 0000	C900

Local Temperature data is represented by an 8-bit, two's complement byte with an LSB equal to 1°C:

Temperature	Digital Output	
	Binary	Hex
+125°C	0111 1101	7D
+25°C	0001 1001	19
+1°C	0000 0001	01
0°C	0000 0000	00
-1°C	1111 1111	FF
-25°C	1110 0111	E7
-55°C	1100 1001	C9

1.6 OPEN-DRAIN OUTPUTS

The SMBDAT, $\overline{\text{ALERT}}$, and PWM outputs are open-drain outputs and do not have internal pull-ups. A "High" level will not be observed on these pins until pull-up current is provided by an internal source, typically through a pull-up resistor. Choice of resistor value depends on several factors but, in general, the value should be as high as possible consistent with reliable operation. This will lower the power dissipation of the LM63 and avoid temperature errors caused by self-heating of the device. The maximum value of the pull-up resistor to provide the 2.1 V high level is 88.7 k Ω .

1.7 DIODE FAULT DETECTION

The LM63 can detect fault conditions caused by the remote diode. If the D+ pin is detected to be shorted to V_{DD} , or open: (1) the Remote Temperature High Byte (RTHB) register is loaded with 127°C, (2) the Remote Temperature Low Byte (RTLb) register is loaded with 0, and (3) the OPEN bit (D2) in the status register is set. Therefore, if the Remote T_CRIT setpoint register (RCS): (1) is set to a value less than +127°C and (2) the ALERT Mask is disabled, then the $\overline{\text{ALERT}}$ output pin will be pulled low. If the Remote High Setpoint High Byte (RHSHB) is set to a value less than +127°C and (2) the ALERT Mask is disabled, then the $\overline{\text{ALERT}}$ will be pulled low. The OPEN bit by itself will not trigger an ALERT.

If the D+ pin is shorted to either ground or D-, then the Remote Temperature High Byte (RTHB) register is loaded with -128°C (1000 0000) and the OPEN bit in the ALERT Status Register will not be set. A temperature reading of -128°C indicates that D+ is shorted to either ground or D-. If the value in the Remote Low Setpoint High Byte (RLSHB) Register is more than -128°C and the ALERT Mask is Disabled, $\overline{\text{ALERT}}$ will be pulled low.

1.8 COMMUNICATING WITH THE LM63

Each data register in the LM63 falls into one of four types of user accessibility:

1. Read Only
2. Write Only
3. Read/Write same address
4. Read/Write different address

A Write to the LM63 is comprised of an address byte and a command byte. A write to any register requires one data byte.

Reading the LM63 Registers can take place after the requisite register setup sequence takes place. See Section 2.1.1 LM63 Required Initial Fan Control Register Sequence.

The data byte has the Most Significant Bit (MSB) first. At the end of a read, the LM63 can accept either Acknowledge or

1.0 Functional Description (Continued)

No-Acknowledge from the Master. Note that the No-Acknowledge is typically used as a signal for the slave indicating that the Master has read its last byte.

1.9 DIGITAL FILTER

The LM63 incorporates a user-configured digital filter to suppress erroneous Remote Temperature readings due to noise. The filter is accessed in the Remote Diode Temperature Filter and Comparator Mode Register. The filter can be set according to the following table.

Level 2 is maximum filtering.

Digital Filter Selection Table

D2	D1	Filter
0	0	No Filter
0	1	Level 1
1	0	Level 1
1	1	Level 2

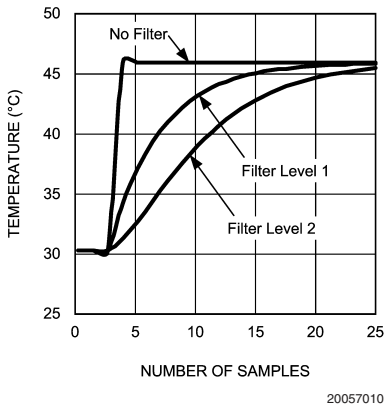

FIGURE 6. Step Response of the Digital Filter

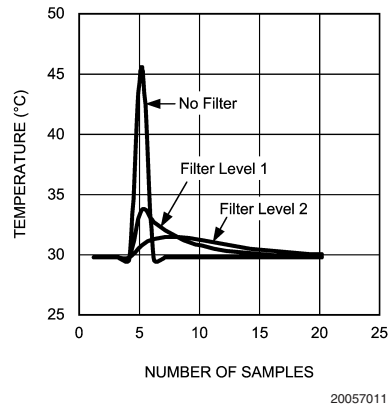

FIGURE 7. Impulse Response of the Digital Filter

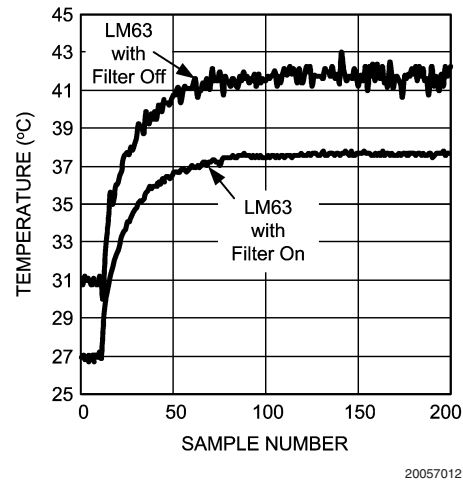
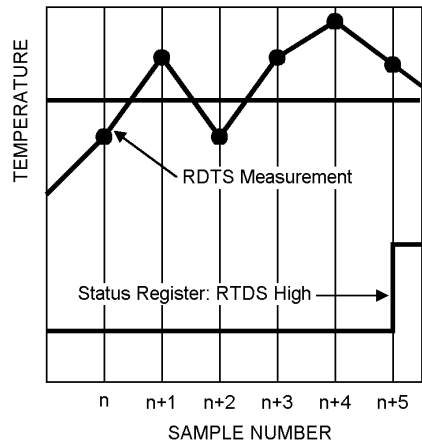

FIGURE 8. Digital Filter Response in an Intel Pentium 4 processor System. The Filter on and off curves were purposely offset to better show noise performance.

1.0 Functional Description (Continued)

1.10 FAULT QUEUE

The LM63 incorporates a Fault Queue to suppress erroneous ALERT triggering. The Fault Queue prevents false triggering by requiring three consecutive out-of-limit HIGH, LOW, or T_CRIT temperature readings. See *Figure 9*. The Fault Queue defaults to OFF upon power-up and may be activated by setting the RDTS Fault Queue bit in the Configuration Register to a 1.



20057013

FIGURE 9. Fault Queue Temperature Response Diagram

1.11 ONE-SHOT REGISTER

The One-Shot Register is used to initiate a single conversion and comparison cycle when the device is in standby mode, after which the data returns to standby. This is not a data register. A write operation causes the one-shot conversion. The data written to this address is irrelevant and is not stored. A zero will always be read from this register.

1.12 SERIAL INTERFACE RESET

In the event that the SMBus Master is reset while the LM63 is transmitting on the SMBDAT line, the LM63 must be returned to a known state in the communication protocol. This may be done in one of two ways:

1. When SMBDAT is Low, the LM63 SMBus state machine resets to the SMBus idle state if either SMBData or SMBCLK are held Low for more than 35 ms (t_{TIMEOUT}). All devices are to timeout when either the SMBCLK or SMBDAT lines are held Low for 25 ms – 35 ms. Therefore, to insure a timeout of all devices on the bus, either the SMBCLK or the SMBData line must be held Low for at least 35 ms.
2. With both SMBDAT and SMBCLK High, the master can initiate an SMBus start condition with a High to Low transition on the SMBDAT line. The LM63 will respond properly to an SMBus start condition at any point during the communication. After the start the LM63 will expect an SMBus Address address byte.

2.0 LM63 Registers

The following pages include: Section 2.1, a Register Map in Hexadecimal Order, which shows a summary of all registers and their bit assignments, Section 2.2, a Register Map in Functional Order, and Section 2.3, a detailed explanation of each register. Do not address the unused or manufacturer's test registers.

2.1 LM63 REGISTER MAP IN HEXADECIMAL ORDER

The following is a Register Map grouped in hexadecimal address order. Some address locations have been left blank to maintain compatibility with LM86. Addresses in parenthesis are mirrors of "Same As" address for backwards compatibility with some older software. Reading or writing either address will access the same 8-bit register.

Register 0x[HEX]	Register Name	DATA BITS							
		D7	D6	D5	D4	D3	D2	D1	D0
00	Local Temperature	LT7	LT6	LT5	LT4	LT3	LT2	LT1	LT0
01	Rmt Temp MSB	RTHB±	RTHB14	RTHB13	RTHB12	RTHB11	RTHB10	RTHB9	RTHB8
02	ALERT Status	BUSY	LHIGH	0	RHIGH	RLOW	RDF A	RCRIT	TACH
03	Configuration	ALTMSK	STBY	PWMDIS	0	0	ALT/TCH	TCRITOV	FLTQUE
04	Conversion Rate	0	0	0	0	CONV3	CONV2	CONV1	CONV0
05	Local High Setpoint	LHS7	LHS6	LHS5	LHS4	LHS3	LHS2	LHS1	LHS0
06	[Reserved]	Not Used							
07	Rmt High Setpoint MSB	RHSHB15	RHSHB14	RHHBS13	RHSHB12	RHSHB11	RHSHB10	RHSHB9	RHSHB8
08	Rmt Low Setpoint MSB	RLSHB15	RLSHB14	RLSHB13	RLSHB12	RLHBS11	RLSHB10	RLSHB9	RLSHB8
(09)	Same as 03								
(0A)	Same as 04								
(0B)	Same as 05								
0C	[Reserved]	Not Used							
(0D)	Same as 07								
(0E)	Same as 08								
0F	One Shot	Write Only. Write command triggers one temperature conversion cycle.							
10	Rmt Temp LSB	RTL B7	RTL B6	RTL B5	0	0	0	0	0
11	Rmt Temp Offset MSB	RTOHB15	RTOHB14	RTOHB13	RTOHB12	RTOHB11	RTOHB10	RTOHB9	RTOHB8
12	Rmt Temp Offset LSB	RTOLB7	RTOLB6	RTOLB5	0	0	0	0	0
13	Rmt High Setpoint LSB	RHSLB7	RHSLB6	RHSLB5	0	0	0	0	0
14	Rmt Low Setpoint LSB	RLSLB7	RLSLB6	RLSLB5	0	0	0	0	0
15	[Reserved]	Not Used							
16	ALERT Mask	1	ALTMSK6	1	ALTMSK4	ALTMSK3	1	ALTMSK1	ALTMSK0
17	[Reserved]	Not Used							
18	[Reserved]	Not Used							
19	Rmt TCRIT Setpoint	RCS7	RCS6	RCS5	RCS4	RCS3	RCS2	RCS1	RCS0
1A–1F	[Reserved]	Not Used							
20	[Reserved]	Not Used							
21	Rmt TCRIT Hysteresis	RTH7	RTH6	RTH5	RTH4	RTH3	RTH2	RTH1	RTH0
22–2F	[Reserved]	Not Used							
30–3F	[Reserved]	Not Used							
40–45	[Reserved]	Not Used							
46	Tach Count LSB	TCLB5	TCLB4	TCLB3	TCLB2	TCLB1	TCLB0	TEDGE1	TEDGE0
47	Tach Count MSB	TCHB13	TCHB12	TCHB11	TCHB10	TCHB9	TCHB8	TCHB7	TCHB6
48	Tach Limit LSB	TLLB7	TLLB6	TLLB5	TLLB4	TLLB3	TLLB2	Not Used	Not Used
49	Tach Limit MSB	TLHB15	TLHB14	TLHB13	TLHB12	TLHB11	TLHB10	TLHB9	TLHB8
4A	PWM and RPM	0	0	PWPGM	PWOUT±	PWCKSL	0	TACH1	TACH0
4B	Fan Spin-Up Config	0	0	SPINUP	SPNDTY1	SPNDTY0	SPNUPT2	SPNUPT1	SPNUPT0
4C	PWM Value	0	0	PWVAL5	PWVAL4	PWVAL3	PWVAL2	PWVAL1	PWVAL0
4D	PWM Frequency	0	0	0	PWFM4	PWFM3	PWFM2	PWFM1	PWFM0
4E	[Reserved]	Not Used							

2.0 LM63 Registers (Continued)

Register 0x[HEX]	Register Name	DATA BITS							
		D7	D6	D5	D4	D3	D2	D1	D0
4F	Lookup Table Hysteresis	0	0	0	LOOKH4	LOOKH3	LOOKH2	LOOKH1	LOOKH0
50–5F	Lookup Table	Lookup Table of up to 8 PWM and Temp Pairs in 8-bit Registers							
60–BE	[Reserved]	Not Used							
BF	Rmt Diode Temp Filter	0	0	0	0	0	RDTF1	RDTF0	ALTCOMP
C0–FD	[Reserved]	Not Used							
FE	Manufacturer's ID	0	0	0	0	0	0	0	1
FF	Stepping/Die Rev. ID	0	1	0	0	0	0	0	1

2.2 LM63 REGISTER MAP IN FUNCTIONAL ORDER

The following is a Register Map grouped in Functional Order. Some address locations have been left blank to maintain compatibility with LM86. Addresses in parenthesis are mirrors of named address. Reading or writing either address will access the same 8-bit register. The Fan Control and Configuration Registers are listed first, as there is a required order to setup these registers first and then setup the others. The detailed explanations of each register will follow the order shown below. POR = Power-On-Reset.

Register [HEX]	Register Name	Read/Write	POR Default [HEX]
FAN CONTROL REGISTERS			
4A	PWM and RPM	R/W	20
4B	Fan Spin-Up Configuration	R/W	3F
4D	PWM Frequency	R/W	17
4C	PWM Value	Read Only (R/W if Override Bit is Set)	00
50–5F	Lookup Table	R/W	See Table
4F	Lookup Table Hysteresis	R/W	04
CONFIGURATION REGISTER			
03 (09)	Configuration	R/W	00
TACHOMETER COUNT AND LIMIT REGISTERS			
46	Tach Count LSB	Read Only	N/A
47	Tach Count MSB	Read Only	N/A
48	Tach Limit LSB	R/W	FF
49	Tach Limit MSB	R/W	FF
LOCAL TEMPERATURE AND LOCAL SETPOINT REGISTERS			
00	Local Temperature	Read Only	N/A
05 (0B)	Local High Setpoint	R/W	46 (70°)
REMOTE DIODE TEMPERATURE AND SETPOINT REGISTERS			
01	Remote Temperature MSB	Read Only	N/A
10	Remote Temperature LSB	Read Only	N/A
11	Remote Temperature Offset MSB	R/W	00
12	Remote Temperature Offset LSB	R/W	00
07 (0D)	Remote High Setpoint MSB	R/W	46 (70°C)
13	Remote High Setpoint LSB	R/W	00
08 (0E)	Remote Low Setpoint MSB	R/W	00 (0°C)
14	Remote Low Setpoint LSB	R/W	00
19	Remote TCRIT Setpoint	R/W	55 (85°C)
21	Remote TCRIT Hys	R/W	0A (10°C)
BF	Remote Diode Temperature Filter	R/W	00
CONVERSION AND ONE-SHOT REGISTERS			
04 (0A)	Conversion Rate	R/W	08
0F	One-Shot	Write Only	N/A

2.0 LM63 Registers (Continued)

Register [HEX]	Register Name	Read/Write	POR Default [HEX]
ALERT STATUS AND MASK REGISTERS			
02	ALERT Status	Read Only	N/A
16	ALERT Mask	R/W	A4
ID AND TEST REGISTERS			
FF	Stepping/Die Rev. ID	Read Only	41
[RESERVED] REGISTERS—NOT USED			
06	Not Used	N/A	N/A
0C	Not Used	N/A	N/A
15	Not Used	N/A	N/A
17	Not Used	N/A	N/A
18	Not Used	N/A	N/A
1A–1F	Not Used	N/A	N/A
20	Not Used	N/A	N/A
22–2F	Not Used	N/A	N/A
30–3F	Not Used	N/A	N/A
40–45	Not Used	N/A	N/A
4E	Not Used	N/A	N/A
60–BE	Not Used	N/A	N/A
C0–FD	Not Used	N/A	N/A

2.3 LM63 INITIAL REGISTER SEQUENCE AND REGISTER DESCRIPTIONS IN FUNCTIONAL ORDER

The following is a Register Map grouped in functional and sequence order. Some address locations have been left blank to maintain compatibility with LM86. Addresses in parenthesis are mirrors of named address for backwards compatibility with some older software. Reading or writing either address will access the same 8-bit register.

2.3.1 LM63 Required Initial Fan Control Register Sequence

Important! The BIOS must follow the sequence below to configure the following Fan Registers for the LM63 before using any of the Fan or Tachometer or PWM registers:

Step	[Register] _{HEX} and Setup Instructions
1	[4A] Write bits 0 and 1; 3 and 4. This includes tach settings if used, PWM internal clock select (1.4 kHz or 360 kHz) and PWM Output Polarity.
2	[4B] Write bits 0 through 5 to program the spin-up settings.
3	[4D] Write bits 0 through 4 to set the frequency settings. This works with the PWM internal clock select.
4	Choose, then write, only one of the following: A. [4F–5F] the Lookup Table, or B. [4C] the PWM value bits 0 through 5.
5	If Step 4A, Lookup Table, was chosen and written then write [4A] bit 5 = 0.

All other registers can be written at any time after the above sequence.

2.0 LM63 Registers (Continued)

LM63 Register Descriptions In Functional Order

Fan Control Registers

Address Hex	Read/Write	Bits	POR Value	Name	Description
4A_{HEX} FAN PWM AND TACHOMETER CONFIGURATION REGISTER					
4A	R/W	7:6	00	PWM Program	These bits are unused and always set to 0.
		5	1		0: the PWM Value (register 4C) and the Lookup Table (50–5F) are read-only. The PWM value (0 to 100%) is determined by the current remote diode temperature and the Lookup Table, and can be read from the PWM value register. 1: the PWM value (register 4C) and the Lookup Table (Register 50–5F) are read/write enabled. Writing the PWM Value register will set the PWM output. This is also the state during which the Lookup Table can be written.
		4	0	PWM Output Polarity	0: the PWM output pin will be 0 V for fan OFF and open for fan ON. 1: the PWM output pin will be open for fan OFF and 0 V for fan ON.
		3	0	PWM Clock Select	if 0, the master PWM clock is 360 kHz if 1, the master PWM clock is 1.4 kHz.
		2	0	[Reserved]	Always write 0 to this bit.
		1:0	00	Tachometer Mode	00: Traditional tach input monitor, false readings when under minimum detectable RPM. 01: Traditional tach input monitor, FFFF reading when under minimum detectable RPM. 10: Most accurate readings, FFFF reading when under minimum detectable RPM. 11: Least effort on programmed PWM of fan, FFFF reading when under minimum detectable RPM. Note: If the PWM Clock is 360 kHz, mode 00 is used regardless of the setting of these two bits.

2.0 LM63 Registers (Continued)

Fan Control Registers (Continued)

Address Hex	Read/Write	Bits	POR Value	Name	Description
4B_{HEX} FAN PWM AND TACHOMETER CONFIGURATION REGISTER					
4B	R/W	7:6	0	Fast Tachometer Spin-Up	These bits are unused and always set to 0
		5	1		If 0, the fan spin-up uses the duty cycle and spin-up time, bits 0–4. If 1, the LM63 sets the PWM output to 100% until the spin-up times out (per bits 0–2) or the minimum desired RPM has been reached (per the Tachometer Setpoint setting) using the tachometer input, whichever happens first. This bit overrides the PWM Spin-Up Duty Cycle register (bits 4:3)—PWM output is always 100%. Register x03, bit 2 = 1 for Tachometer mode. If PWM Spin-Up Time (bits 2:0) = 000, the Spin-Up cycle is bypassed, regardless of the state of this bit.
		4:3	11	PWM Spin-Up Duty Cycle	00: Spin-Up cycle bypassed (no Spin-Up), unless Fast Tachometer Terminated Spin-Up (bit 5) is set. 01: 50% 10: 75%–81% Depends on PWM Frequency. See Applications Notes. 11: 100%
		2:0	111	PWM Spin-Up Time	000: Spin-Up cycle bypassed (No Spin-Up) 001: 0.05 seconds 010: 0.1 s 011: 0.2 s 100: 0.4 s 101: 0.8 s 110: 1.6 s 111: 3.2 s
4D_{HEX} FAN PWM FREQUENCY REGISTER					
4D	R/W	7:5	000	PWM Frequency	These bits are unused and always set to 0
		4:0	10111		The PWM Frequency = PWM_Clock / 2n, where PWM_Clock = 360 kHz or 1.4 kHz (per the PWM Clock Select bit in Register 4A), and n = value of the register. Note: n = 0 is mapped to n = 1. See the Application Note at the end of this datasheet.
4C_{HEX} PWM VALUE REGISTER					
4C	Read (Write only if reg 4A bit 5 = 1.)	7:6	00	PWM Value	These bits are unused and always set to 0
		5:0	000000		If PWM Program (register 4A, bit 5) = 0 this register is read only and reflects the LM63's current PWM value from the Lookup Table. If PWM Program (register 4A, bit 5) = 1, this register is read/write and the desired PWM value is written directly to this register, instead of from the Lookup Table, for direct fan speed control. This register will read 0 during the Spin-Up cycle. See Application Notes section at the end of this datasheet for more information regarding the PWM Value and Duty Cycle in %.

2.0 LM63 Registers (Continued)

Fan Control Registers (Continued)

Address Hex	Read/Write	Bits	POR Value	Name	Description
50_{HEX} to 5F_{HEX} LOOKUP TABLE (7 Bits for Temperature and 6 Bits for PWM for each Temperature/PWM Pair)					
50	Read. (Write only if reg 4A bit 5 = 1.)	7	0	Lookup Table Temperature Entry 1	This bit is unused and always set to 0.
		6:0	0x7F		If the remote diode temperature exceeds this value, the PWM output will be the value in Register 51.
51		7:6	00	Lookup Table PWM Entry 1	These bits are unused and always set to 0.
		5:0	0x3F		The PWM value corresponding to the temperature limit in register 50.
52		7	0	Lookup Table Temperature Entry 2	This bit is unused and always set to 0.
		6:0	0x7F		If the remote diode temperature exceeds this value, the PWM output will be the value in Register 53.
53		7:6	00	Lookup Table PWM Entry 2	These bits are unused and always set to 0.
		5:0	0x3F		The PWM value corresponding to the temperature limit in register 52.
54		7	0	Lookup Table Temperature Entry 3	This bit is unused and always set to 0.
		6:0	0x7F		If the remote diode temperature exceeds this value, the PWM output will be the value in Register 55.
55		7:6	00	Lookup Table PWM Entry 3	These bits are unused and always set to 0.
		5:0	0x3F		The PWM value corresponding to the temperature limit in register 54.
56		7	0	Lookup Table Temperature Entry 4	This bit is unused and always set to 0.
		6:0	0x7F		If the remote diode temperature exceeds this value, the PWM output will be the value in Register 57.
57		7:6	00	Lookup Table PWM Entry 4	These bits are unused and always set to 0.
		5:0	0x3F		The PWM value corresponding to the temperature limit in register 56.
58	7	0	Lookup Table Temperature Entry 5	This bit is unused and always set to 0.	
	6:0	0x7F		If the remote diode temperature exceeds this value, the PWM output will be the value in Register 59.	
59	7:6	00	Lookup Table PWM Entry 5	These bits are unused and always set to 0.	
	5:0	0x3F		The PWM value corresponding to the temperature limit in register 58.	
5A	7	0	Lookup Table Temperature Entry 6	This bit is unused and always set to 0.	
	6:0	0x7F		If the remote diode temperature exceeds this value, the PWM output will be the value in Register 5B.	
5B	7:6	00	Lookup Table PWM Entry 6	These bits are unused and always set to 0.	
	5:0	0x3F		The PWM value corresponding to the temperature limit in register 5A.	
5C	7	0	Lookup Table Temperature Entry 7	This bit is unused and always set to 0.	
	6:0	0x7F		If the remote diode temperature exceeds this value, the PWM output will be the value in Register 5D.	
5D	7:6	00	Lookup Table PWM Entry 7	These bits are unused and always set to 0.	
	5:0	0x3F		The PWM value corresponding to the temperature limit in register 5C.	
5E	7	0	Lookup Table Temperature Entry 8	This bit is unused and always set to 0.	
	6:0	0x7F		If the remote diode temperature exceeds this value, the PWM output will be the value in Register 5F.	
5F	7:6	00	Lookup Table PWM Entry 8	These bits are unused and always set to 0.	
	5:0	0x3F		The PWM value corresponding to the temperature limit in register 5E.	
4F_{HEX} LOOKUP TABLE HYSTERESIS					
4F	R/W	7:5	000	Lookup Table Hysteresis	These bits are unused and always set to 0
		4:0	00100		The amount of hysteresis applied to the Lookup Table. (1 LSB = 1°C).

2.0 LM63 Registers (Continued)

Configuration Register

ADDRESS Hex	Read/ Write	Bits	POR Value	Name	Description
03 (09)_{HEX} CONFIGURATION REGISTER					
03 (09)	R/W	7	0	ALERT Mask	When this bit is a 0, ALERT interrupts are enabled. When this bit is set to a 1, ALERT interrupts are masked, and the $\overline{\text{ALERT}}$ pin is always in a high impedance (open) state.
		6	0	STANDBY	When this bit is a 0, the LM63 is in operational mode, converting, comparing, and updating the PWM output continuously. When this bit is a 1, the LM63 enters a low power standby mode. In STANDBY, continuous conversions are stopped, but a conversion/comparison cycle may be initiated by writing any value to register 0x0F. Operation of the PWM output in STANDBY depends on the setting of bit 5 in this register.
		5	0	PWM Disable in STANDBY	When this bit is a 0, the LM63's PWM output continues to output the current fan control signal while in STANDBY. When this bit is a 1, the PWM output is disabled (as defined by the PWM polarity bit) while in STANDBY.
		4:3	00		These bits are unused and always set to 0.
		2	0	$\overline{\text{ALERT}}$ /Tach Select	When this bit is a 0, the $\overline{\text{ALERT}}$ /Tach pin is an open drain $\overline{\text{ALERT}}$ output. When this bit is a 1, the $\overline{\text{ALERT}}$ /Tach pin is a high impedance Tachometer input. Note that if this bit is set, the function of the $\overline{\text{ALERT}}$ /Tach pin must be Tach input, so an <i>external</i> ALERT condition will not occur.
		1	0	T_CRIT Limit Override	The T_CRIT limit for the remote diode is nominally 85°C. This value can be changed once after power-up by first setting this bit to a 1, then programming a new T_CRIT value into the Remote Diode T_CRIT Limit (register 0x19). The T_CRIT value can not be changed again except by cycling power to the LM63.
		0	0	RDTS Fault Queue	0: an ALERT will be generated if any Remote Diode conversion result is above the Remote High Set Point or below the Remote Low Setpoint . 1: an ALERT will be generated only if three consecutive Remote Diode conversions are above the Remote High Set Point or below the Remote Low Setpoint .

2.0 LM63 Registers (Continued)

Tachometer Count And Limit Registers

ADDRESS Hex	Read/Write	Bits	POR Value	Name	Description															
47_{HEX} TACHOMETER COUNT (MSB) and 46_{HEX} TACHOMETER COUNT (LSB) REGISTERS (16 bits: Read LSB first to lock MSB and ensure MSB and LSB are from the same reading)																				
47	Read Only	7:0	N/A	Tachometer Count (MSB)	These registers contain the current 16-bit Tachometer Count, representing the period of time between tach pulses. Note that the 16-bit tachometer MSB and LSB are reversed from the 16-bit temperature readings.															
	Read Only	7:2	N/A	Tachometer Count (LSB)																
46	Read Only	1:0	00	Tachometer Edge Count	<table border="1"> <thead> <tr> <th>Bits</th> <th>Edges Used</th> <th>Tach_Count_Multiple</th> </tr> </thead> <tbody> <tr> <td>00:</td> <td></td> <td>Reserved - do not use</td> </tr> <tr> <td>01:</td> <td>2</td> <td>4</td> </tr> <tr> <td>10:</td> <td>3</td> <td>2</td> </tr> <tr> <td>11:</td> <td>5</td> <td>1</td> </tr> </tbody> </table>	Bits	Edges Used	Tach_Count_Multiple	00:		Reserved - do not use	01:	2	4	10:	3	2	11:	5	1
					Bits	Edges Used	Tach_Count_Multiple													
					00:		Reserved - do not use													
					01:	2	4													
					10:	3	2													
11:	5	1																		
Note: If PWM_Clock_Select = 360 kHz, then Tach_Count_Multiple = 1 regardless of the setting of these bits.																				
49_{HEX} TACHOMETER LIMIT (MSB) and 48_{HEX} TACHOMETER LIMIT (LSB) REGISTERS																				
49	R/W	7:0	0xFF	Tachometer Limit (MSB)	These registers contain the current 16-bit Tachometer Count, representing the period of time between tach pulses. Fan RPM = (f * 5,400,000) / (Tachometer Count), where f = 1 for 2 pulses/rev fan; f = 2 for 1 pulse/rev fan; and f = 2/3 for 3 pulses/rev fan. See the Applications Notes section for more tachometer information. Note that the 16-bit tachometer MSB and LSB are reversed from the 16 bit temperature readings.															
48	R/W	7:2	0xFF	Tachometer Limit (LSB)																
	R/W	1:0		[Reserved]		Not Used.														

Local Temperature And Local High Setpoint Registers

ADDRESS Hex	Read/Write	Bits	POR Value	Name	Description
00_{HEX} LOCAL TEMPERATURE REGISTER (8-bits)					
00	Read Only	7:0	N/A	Local Temperature Reading (8-bit)	8-bit integer representing the temperature of the LM63 die.
05 (0B)_{HEX} LOCAL HIGH SETPOINT REGISTER (8-bits)					
05	R/W	7:0	0x46 (70°)	Local HIGH Setpoint	High Setpoint for the internal diode.

2.0 LM63 Registers (Continued)

Remote Diode Temperature, Offset And Setpoint Registers

ADDRESS Hex	Read/Write	Bits	POR Value	Name	Description
01	Read Only	7:0	N/A	Remote Diode Temperature Reading (MSB)	This is the MSB of the 2's complement value, representing the temperature of the remote diode connected to the LM63. Bit 7 is the sign bit, bit 6 has a weight of 0x40 (64°), and bit 0 has a weight of 1°C. This byte to be read first.
10	Read Only	7:5	N/A	Remote Diode Temperature Reading (MSB)	This is the LSB of the 2's complement value, representing the temperature of the remote diode connected to the LM63. Bit 7 has a weight 0.5°C, bit 6 has a weight of 0.25°C, and bit 5 has a weight of 0.125°C.
		4:0	00		Always 00.
11	R/W	7:5	00	Remote Temperature OFFSET (MSB)	These registers contain the value added to or subtracted from the remote diode's reading to compensate for the different non-ideality factors of different processors, diodes, etc. The 2's complement value, in these registers is added to the output of the LM63's ADC to form the temperature reading contained in registers 01 and 10.
12	R/W	7:5	00	Remote Temperature OFFSET (LSB)	
07 (0D)	R/W	7:0	0x46 (70°C)	Remote HIGH Setpoint (MSB)	High setpoint temperature for remote diode. Same format as Remote Temperature Reading (registers 01 and 10).
		4:0	00	Remote HIGH Setpoint (LSB)	
13	R/W	7:5	00	Remote HIGH Setpoint (MSB)	Always 00.
		4:0	00	Remote HIGH Setpoint (LSB)	
08 (0E)	R/W	7:0	00 (0°C)	Remote LOW Setpoint (MSB)	Low setpoint temperature for remote diode. Same format as Remote Temperature Reading (registers 01 and 10).
		4:0	00	Remote LOW Setpoint (LSB)	
14	R/W	7:5	00	Remote LOW Setpoint (MSB)	Always 00.
		4:0	00	Remote LOW Setpoint (LSB)	
19	R/W	7:0	0x55 (85°C)	Remote Diode T_CRIT Limit	This 8-bit integer storing the T_CRIT limit is nominally 85°C. This value can be changed once after power-up by setting T_CRIT Limit Override (bit 1) in the Configuration register to a 1, then programming a new T_CRIT value into this register. The T_CRIT Limit can not be changed again except by cycling power to the LM63.
21	R/W	7:0	0x0A (10°C)	Remote Diode T_CRIT Hysteresis	8-bit integer storing T_CRIT hysteresis. T_CRIT stays activated until the remote diode temperature goes below [(T_CRIT Limit)—(T_CRIT Hysteresis)].
BF	R/W	7:3	00000		These bits are unused and should always set to 0.
		2:1	00	Remote Diode Temperature Filter	00: Filter Disabled 01: Filter Level 1 (minimal filtering, same as 10) 10: Filter Level 1 (minimal filtering, same as 01) 11: Filter Level 2 (maximum filtering)
		0	0	Comparator Mode	0: the $\overline{\text{ALERT}}$ /Tach pin functions normally. 1: the $\overline{\text{ALERT}}$ Tach pin behaves as a comparator, asserting itself when an ALERT condition exists, de-asserting itself when the ALERT condition goes away.

2.0 LM63 Registers (Continued)

ALERT Status And Mask Registers

ADDRESS Hex	Read/ Write	Bits	POR Value	Name	Description
02_{HEX} ALERT STATUS REGISTER (8-bits) (All Alarms are latched until read, then cleared if alarm condition was removed at the time of the read.)					
0x02	Read Only	7	0	Busy	When this bit is a 0, the ADC is not converting. When this bit is set to a 1, the ADC is performing a conversion. This bit does not affect ALERT status.
		6	0	Local High Alarm	When this bit is a 0, the internal temperature of the LM63 is at or below the Local High Setpoint. When this bit is a 1, the internal temperature of the LM63 is above the Local High Setpoint, and an ALERT is triggered.
		5	0		This bit is unused and always read as 0.
		4	0	Remote High Alarm	When this bit is a 0, the temperature of the Remote Diode is at or below the Remote High Setpoint. When this bit is a 1, the temperature of the Remote Diode is above the Remote High Setpoint, and an ALERT is triggered.
		3	0	Remote Low Alarm	When this bit is a 0, the temperature of the Remote Diode is at or above the Remote Low Setpoint. When this bit is a 1, the temperature of the Remote Diode is below the Remote Low Setpoint, and an ALERT is triggered.
		2	0	Remote Diode Fault Alarm	When this bit is a 0, the Remote Diode appears to be correctly connected. When this bit is a 1, the Remote Diode may be disconnected or shorted. This Alarm does not trigger an ALERT.
		1	0	Remote T_CRIT Alarm	When this bit is a 0, the temperature of the Remote Diode is at or below the T_CRIT Limit. When this bit is a 1, the temperature of the Remote Diode is above the T_CRIT Limit, and an ALERT is triggered..
		0	0	Tach Alarm	When this bit is a 0, the Tachometer count is lower than or equal to the Tachometer Limit (the RPM of the fan is greater than or equal to the minimum desired RPM). When this bit is a 1, the Tachometer count is higher than the Tachometer Limit (the RPM of the fan is less than the minimum desired RPM), and an ALERT is triggered. Note that if this bit is set, the function of the $\overline{\text{ALERT}}$ /Tach pin must be Tach input, so an <i>external</i> ALERT condition will not be generated. The user may read the status register periodically to find out if and ALERT condition has occurred.

2.0 LM63 Registers (Continued)

ALERT Status And Mask Registers (Continued)

ADDRESS Hex	Read/Write	Bits	POR Value	Name	Description
16_{HEX} ALERT MASK REGISTER (8-bits)					
16	R/W	7	1		This bit is unused and always read as 1.
		6	0	Local High Alarm Mask	When this bit is a 0, a Local High Alarm event will generate an ALERT. When this bit is a 1, a Local High Alarm will not generate an ALERT
		5	1		This bit is unused and always read as 1.
		4	0	Remote High Alarm Mask	When this bit is a 0, Remote High Alarm event will generate an ALERT. When this bit is a 1, a Remote High Alarm event will not generate an ALERT.
		3	0	Remote Low Alarm Mask	When this bit is a 0, a Remote Low Alarm event will generate an ALERT. When this bit is a 1, a Remote Low Alarm event will not generate an ALERT.
		2	1		This bit is unused and always read as 1.
		1	0	Remote T_CRIT Alarm Mask	When this bit is a 0, a Remote T_CRIT event will generate an ALERT. When this bit is a 1, a Remote T_CRIT event will not generate an ALERT.
		0	0	Tach Alarm Mask	When this bit is a 0, a Tach Alarm event will generate an ALERT. When this bit is a 1, a Tach Alarm event will not generate an ALERT.

Conversion Rate And One-Shot Registers

ADDRESS Hex	Read/Write	Bits	POR Value	Name	Description
04 (0A)_{HEX} CONVERSION RATE REGISTER (8-bits)					
04 (0A)	R/W	7:0	0x08	Conversion Rate	Sets the conversion rate of the LM63. 00000000 = 0.0625 Hz 00000001 = 0.125 Hz 00000010 = 0.25 Hz 00000011 = 0.5 Hz 00000100 = 1 Hz 00000101 = 2 Hz 00000110 = 4 Hz 00000111 = 8 Hz 00001000 = 16 Hz 00001001 = 32 Hz All other values = 32 Hz
04 (0A)_{HEX} ONE-SHOT REGISTER (8-bits)					
0F	Write Only	7:0	N/A	One Shot Trigger	With the LM63 in the STANDBY mode a single write to this register will initiate one complete temperature conversion cycle.

ID Registers

ADDRESS Hex	Read/Write	Bits	POR Value	Name	Description
FF_{HEX} STEPPING / DIE REVISION ID REGISTER (8-bits)					
FF	Read Only	7:0	0x41	Stepping/Die Revision ID	Version of LM63
FE_{HEX} MANUFACTURER'S ID REGISTER (8-bits)					
FE	Read Only	7:0	0x01	Manufacturer's ID	0x01 = National Semiconductor

3.0 Application Notes

3.1 FAN CONTROL DUTY CYCLE VS. REGISTER SETTINGS AND FREQUENCY

PWM Freq 4D [4:0]	Step Resolution, %	PWM Value 4D [5:0] for 100%	PWM Value 4C [5:0] for about 75%	PWM Value 4C [5:0] for 50%	PWM Freq at 360 kHz Internal Clock, kHz	PWM Freq at 1.4 kHz Internal Clock, Hz	Actual Duty Cycle, % When 75% is Selected
0	Address 0 is mapped to Address 1						
1	50	2	1	1	180.0	703.1	50.0
2	25	4	3	2	90.00	351.6	75.0
3	16.7	6	5	3	60.00	234.4	83.3
4	12.5	8	6	4	45.00	175.8	75.0
5	10.0	10	8	5	36.00	140.6	80.0
6	8.33	12	9	6	30.00	117.2	75.0
7	7.14	14	11	7	25.71	100.4	78.6
8	6.25	16	12	8	22.50	87.9	75.0
9	5.56	18	14	9	20.00	78.1	77.8
10	5.00	20	15	10	18.00	70.3	75.0
11	4.54	22	17	11	16.36	63.9	77.27
12	4.16	24	18	12	15.00	58.6	75.00
13	3.85	26	20	13	13.85	54.1	76.92
14	3.57	28	21	14	12.86	50.2	75.00
15	3.33	30	23	15	12.00	46.9	76.67
16	3.13	32	24	16	11.25	43.9	75.00
17	2.94	34	26	17	10.59	41.4	76.47
18	2.78	36	27	18	10.00	39.1	75.00
19	2.63	38	29	19	9.47	37.0	76.32
20	2.50	40	30	20	9.00	35.2	75.00
21	2.38	42	32	21	8.57	33.5	76.19
22	2.27	44	33	22	8.18	32.0	75.00
23	2.17	46	35	23	7.82	30.6	76.09
24	2.08	48	36	24	7.50	29.3	75.00
25	2.00	50	38	25	7.20	28.1	76.00
26	1.92	52	39	26	6.92	27.0	75.00
27	1.85	54	41	27	6.67	26.0	75.93
28	1.79	56	42	28	6.42	25.1	75.00
29	1.72	58	44	29	6.21	24.2	75.86
30	1.67	60	45	30	6.00	23.4	75.00
31	1.61	62	47	31	5.81	22.7	75.81

3.1.1 Computing Duty Cycles for a Given Frequency

Select a PWM Frequency from the first column corresponding to the desired actual frequency in columns 6 or 7. Note the PWM Value for 100% Duty Cycle.

Find the Duty Cycle by taking the PWM Value of Register 4C and computing:

$$\text{DutyCycle } _(\%) = \frac{\text{PWM } _ \text{Value}}{\text{PWM } _ \text{Value } _ \text{ for } _ 100\%} \times 100\%$$

Example: For a PWM Frequency of 24, a PWM Value at 100% = 48 and PWM Value actual = 28, then the Duty Cycle is $(28/48) \times 100\% = 58.3\%$.

3.0 Application Notes (Continued)

3.2 USE OF THE LOOKUP TABLE FOR NON-LINEAR PWM VALUES VS TEMPERATURE

The Lookup Table, Registers 50 through 5F, can be used to create a non-linear PWM vs Temperature curve that could be used to reduce the acoustic noise from processor fan due to linear or step transfer functions. An example is given below:

EXAMPLE:

In a particular system it was found that the best acoustic fan noise performance was found to occur when the PWM vs Temperature transfer function curve was parabolic in shape. From 25°C to 105°C the fan is to go from 20% to 100%. Since there are 8 steps to the Lookup Table we will break up the Temperature range into 8 separate temperatures. For the 80°C over 8-steps = 10°C per step. This takes care of the x-axis.

For the PWM Value, we first select the PWM Frequency. In this example we will make the PWM Frequency (Register 4C) 20.

For 100% Duty Cycle then, the PWM value is 40. For 20% the minimum is 40 x (0.2) = 8.

We can then arrange the PWM, Temperature pairs in a parabolic fashion in the form of $y = 0.005 \cdot (x - 25)^2 + 8$

Temperature	PWM Value Calculated	Closest PWM Value
25	8.0	8
35	8.5	9
45	10.0	10
55	12.5	13
65	16.0	16
75	20.5	21
85	26.0	26
95	32.5	33
105	40.0	40

We can then program the Lookup Table with the temperature and Closest PWM Values required for the curve required in our example.

3.3 NON-IDEALITY FACTOR AND TEMPERATURE ACCURACY

The LM63 can be applied to remote diode sensing in the same way as other integrated-circuit temperature sensors. It can be soldered to a printed-circuit board, and because the path of best thermal conductivity is between the die and the pins, its temperature will effectively be that of the printed-circuit board lands and traces soldered to its pins. This presumes that the ambient air temperature is nearly the same as the surface temperature of the printed-circuit board. If the air temperature is much higher or lower than the surface temperature, the actual temperature of the LM63 die will be an intermediate temperature between the surface and air temperatures. Again, the primary thermal conduction path is through the leads, so the circuit board surface temperature will contribute to the die temperature much more than the air temperature.

To measure the temperature external to the die use a remote diode. This diode can be located on the die of the target IC, such as a CPU processor chip, allowing measurement of the IC's temperature, independent of the LM63's temperature.

The LM63 has been optimized for use with the thermal diode on the die of an Intel Pentium 4 or a Mobile Pentium 4 Processor-M processor.

A discrete diode can also be used to sense the temperature of external objects or ambient air. Remember that a discrete diode's temperature will be affected, and often dominated by, the temperature of its leads.

Most silicon diodes do not lend themselves well to this application. It is recommended that a diode-connected 2N3904 transistor be used. The base of the transistor is connected to the collector and becomes the anode. The emitter is the cathode.

A LM63 with a diode-connected 2N3904 transistor approximates the temperature reading of the LM63 with the Pentium 4 processor by 1°C.

$$T_{2N3904} = T_{PENTIUM\ 4} - 1^{\circ}C$$

3.3.1 Diode Non_Ideality

When a transistor is connected to a diode the following relationship holds for V_{be} , T , and I_F :

$$I_F = I_S \cdot \left[e^{\left(\frac{V_{be}}{\eta \cdot V_T} \right)} - 1 \right]$$

where

$$V_T = \frac{kT}{q}$$

- $q = 1.6 \times 10^{-19}$ Coulombs (the electron charge)
- T = Absolute Temperature in Kelvin
- $k = 1.38 \times 10^{-23}$ joules/K (Boltzmann's constant)
- η is the non-ideality factor of the manufacturing process used to make the thermal diode
- I_S = Saturation Current and is process dependent
- I_F = Forward Current through the base emitter junction
- V_{be} = Base Emitter Voltage Drop

In the active region, the -1 term is negligible and may be eliminated, yielding the following equation

$$I_F = I_S \cdot \left[e^{\left(\frac{V_{be}}{\eta \cdot V_T} \right)} \right]$$

In the above equation, η and I_S are dependent upon the process that was used in the fabrication of the particular diode. By forcing two currents with a very controlled ratio (N) and measuring the resulting voltage difference, it is possible to eliminate the I_S term. Solving for the forward voltage difference yields the relationship:

$$\Delta V_{be} = \eta \left(\frac{kT}{q} \right) \cdot \ln(N)$$

The voltage seen by the LM63 also includes the $I_F \times R_S$ voltage drop across the internal series resistance of the

3.0 Application Notes (Continued)

Pentium 4 processor's thermal diode. The non-ideality factor, η , is the only other parameter not accounted for and depends on the diode that is used for measurement. Since ΔV_{be} is proportional to both η and T , the variations in η cannot be distinguished from variations in temperature. Since the temperature sensor does not control the non-ideality factor, it will directly add to the inaccuracy of the sensor.

For the Intel Pentium 4 and Mobile Pentium 4 Processor-M processors Intel specifies a $\pm 0.1\%$ variation in η from part to part. As an example, assume that a temperature sensor has an accuracy specification of $\pm 1\%^\circ\text{C}$ at room temperature of 25°C and process used to manufacture the diode has a non-ideality variation of $\pm 0.1\%$. The resulting accuracy will be:

$$T_{ACC} = \pm 1^\circ\text{C} + (\pm 0.1\% \text{ of } 298^\circ\text{K}) = \pm 1.3^\circ\text{C}$$

The additional inaccuracy in the temperature measurement caused by η , can be eliminated if each temperature sensor is calibrated with the remote diode that it will be paired with. Refer to the processor datasheet for the non-ideality factor.

3.3.2 Compensating for Diode Non-Ideality

In order to compensate for the errors introduced by non-ideality, the temperature sensor is calibrated for a particular processor. National Semiconductor temperature sensors are always calibrated to the typical non-ideality of a particular processor type.

The LM63 is calibrated for the non-ideality of the 0.13 micron Intel Pentium 4 and Mobile Pentium 4 Processor-M processors.

When a temperature sensor, calibrated for a specific type of processor is used with a different processor type or a given processor type has a non-ideality that strays from the typical value, errors are introduced.

Temperature errors associated with non-ideality may be introduced in a specific temperature range of concern through the use of the Temperature Offset Registers 11_{HEX} and 12_{HEX}.

The user is encouraged to send an e-mail to hardware.monitor.team@nsc.com to further request information on our recommended setting of the offset register for different processor types.

3.4 COMPUTING RPM OF THE FAN FROM THE TACH COUNT

The Tach Count Registers 46_{HEX} and 47_{HEX} count the number of periods of the 90 kHz tachometer clock in the LM63 for the tachometer input from the fan assuming a 2 pulse per revolution fan tachometer, such as the fans supplied with the Pentium 4 boxed processors. The RPM of the fan can be computed from the Tach Count Registers 46_{HEX} and 47_{HEX}. This can best be shown through an example.

Example:

Given: the fan used has a tachometer output with 2 per revolution.

Let:

Register 46 (LSB) is BF_{HEX} = Decimal (11 x 16) + 15 = 191 and

Register 47 (MSB) is 7_{HEX} = Decimal (7 x 256) = 1792.

The total Tach Count, in decimal, is 191 + 1792 = **1983**.

The RPM is computed using the formula

$$\text{Fan _ RPM} = \frac{f \times 5,400,000}{\text{Total _ Tach _ Count _ (Decimal)}}$$

where

f = 1 for 2 pulses/rev fan tachometer output;

f = 2 for 1 pulse/rev fan tachometer output, and

f = 2 / 3 for 3 pulses/rev fan tachometer output

For our example

$$\text{Fan _ RPM} = \frac{1 \times 5,400,000}{1983} = 2723 _ \text{RPM}$$

3.0 Application Notes (Continued)

3.5 PCB LAYOUT FOR MINIMIZING NOISE



FIGURE 10. Ideal Diode Trace Layout

In a noisy environment, such as a processor mother board, layout considerations are very critical. Noise induced on traces running between the remote temperature diode sensor and the LM63 can cause temperature conversion errors. Keep in mind that the signal level the LM63 is trying to measure is in microvolts. The following guidelines should be followed:

1. Place a 0.1 μF power supply bypass capacitor as close as possible to the V_{DD} pin and the recommended 2.2 nF capacitor as close as possible to the LM63's D+ and D- pins. Make sure the traces to the 2.2 nF capacitor are matched.
2. Ideally, the LM63 should be placed within 10 cm of the Processor diode pins with the traces being as straight, short and identical as possible. Trace resistance of 1 Ω can cause as much as 1°C of error. This error can be compensated by using the Remote Temperature Offset Registers, since the value placed in these registers will automatically be subtracted from or added to the remote temperature reading.
3. Diode traces should be surrounded by a GND guard ring to either side, above and below if possible. This GND

guard should not be between the D+ and D- lines. In the event that noise does couple to the diode lines it would be ideal if it is coupled common mode. That is equally to the D+ and D- lines.

4. Avoid routing diode traces in close proximity to power supply switching or filtering inductors.
5. Avoid running diode traces close to or parallel to high speed digital and bus lines. Diode traces should be kept at least 2 cm apart from the high speed digital traces.
6. If it is necessary to cross high speed digital traces, the diode traces and the high speed digital traces should cross at a 90 degree angle.
7. The ideal place to connect the LM63's GND pin is as close as possible to the Processor's GND associated with the sense diode.
8. Leakage current between D+ and GND should be kept to a minimum. One nano-ampere of leakage can cause as much as 1°C of error in the diode temperature reading. Keeping the printed circuit board as clean as possible will minimize leakage current.

Noise coupling into the digital lines greater than 400 mVp-p (typical hysteresis) and undershoot less than 500 mV below GND, may prevent successful SMBus communication with the LM63. SMBus no acknowledge is the most common symptom, causing unnecessary traffic on the bus. Although the SMBus maximum frequency of communication is rather low (100 kHz max), care still needs to be taken to ensure proper termination within a system with multiple parts on the bus and long printed circuit board traces. An RC lowpass filter with a 3 dB corner frequency of about 40 MHz is included on the LM63's SMBCLK input. Additional resistance can be added in series with the SMBData and SMBCLK lines to further help filter noise and ringing. Minimize noise coupling by keeping digital traces out of switching power supply areas as well as ensuring that digital lines containing high speed data communications cross at right angles to the SMBData and SMBCLK lines.

Physical Dimensions inches (millimeters) unless otherwise noted

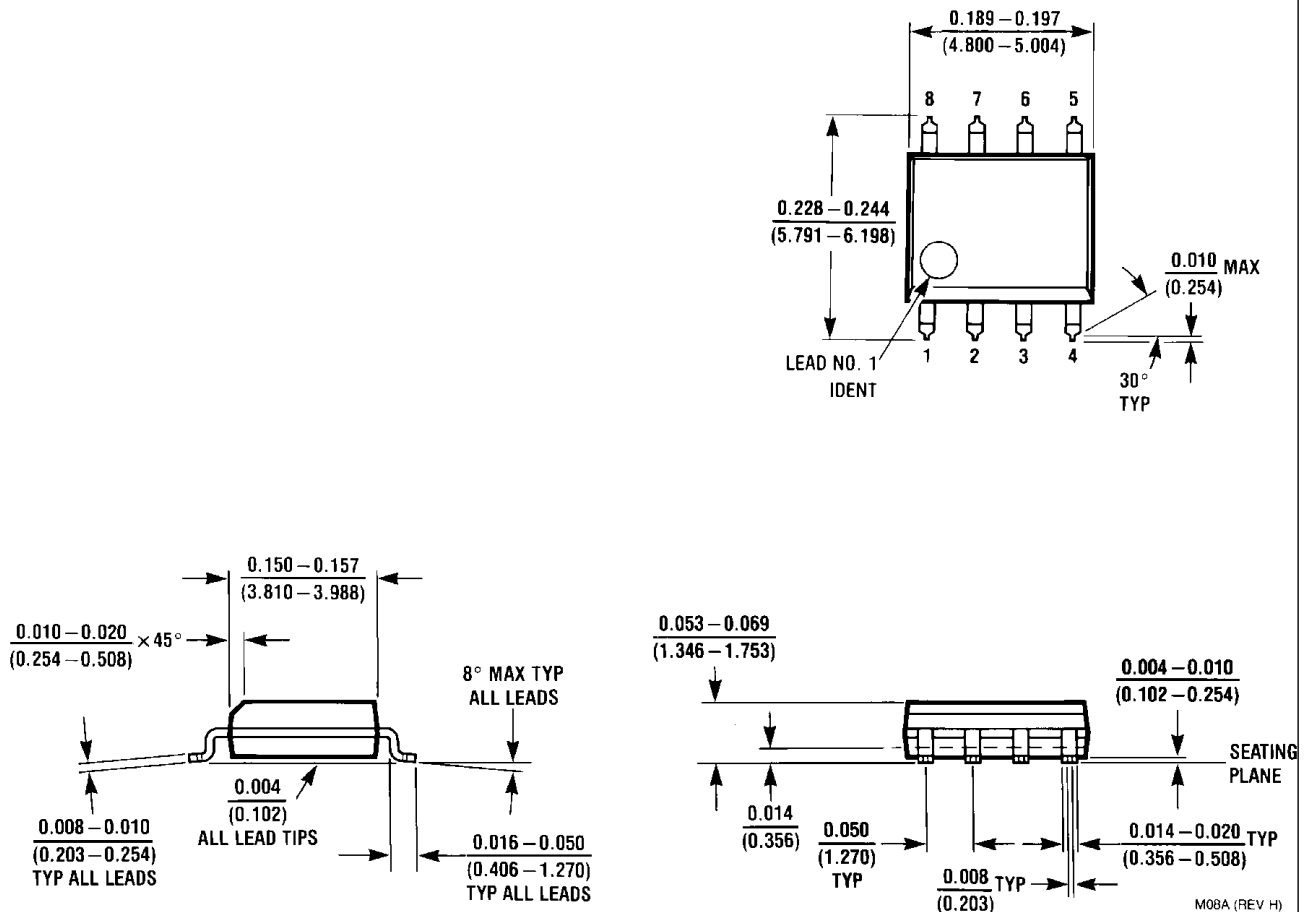

8-Lead (0.154-Inch Wide) Molded Narrow Small-Outline Package (SOIC)
 JEDEC Registration Number MS-012
 Order Number LM63CIM
 NS Package Number M008A

LIFE SUPPORT POLICY

NATIONAL'S PRODUCTS ARE NOT AUTHORIZED FOR USE AS CRITICAL COMPONENTS IN LIFE SUPPORT DEVICES OR SYSTEMS WITHOUT THE EXPRESS WRITTEN APPROVAL OF THE PRESIDENT AND GENERAL COUNSEL OF NATIONAL SEMICONDUCTOR CORPORATION. As used herein:

1. Life support devices or systems are devices or systems which, (a) are intended for surgical implant into the body, or (b) support or sustain life, and whose failure to perform when properly used in accordance with instructions for use provided in the labeling, can be reasonably expected to result in a significant injury to the user.
2. A critical component is any component of a life support device or system whose failure to perform can be reasonably expected to cause the failure of the life support device or system, or to affect its safety or effectiveness.

 **National Semiconductor**
 Americas Customer Support Center
 Email: new.feedback@nsc.com
 Tel: 1-800-272-9959

National Semiconductor
 Europe Customer Support Center
 Fax: +49 (0) 180-530 85 86
 Email: europe.support@nsc.com
 Deutsch Tel: +49 (0) 69 9508 6208
 English Tel: +44 (0) 870 24 0 2171
 Français Tel: +33 (0) 1 41 91 8790

National Semiconductor
 Asia Pacific Customer Support Center
 Email: ap.support@nsc.com

National Semiconductor
 Japan Customer Support Center
 Fax: 81-3-5639-7507
 Email: jpn.feedback@nsc.com
 Tel: 81-3-5639-7560

www.national.com

National does not assume any responsibility for use of any circuitry described, no circuit patent licenses are implied and National reserves the right at any time without notice to change said circuitry and specifications.