

Visible Red Class II Laser Width/Profile Measurement Sensor Providing High-Speed Precision Measurement with Flexible Operation

- FDA Class II IEC Class 2 visible red laser ensures ease of optical axis adjustment
- 5 micron resolution maximum
- 1 to 5 VDC analog output with a light-on dark-operate switch
- 2 programmable discrimination outputs with indicator
- 30 mm and 10 mm beam widths
- 40 mm fixed distance or 0 to 300 mm sensing distance
- 5 input functions
- Digital display in millimeters or analog voltage output



Ordering Information

■ SENSORS/AMPLIFIERS

Sensors on Standard Models

Emitters and receivers are not available separately.

Sensing distance	Measurement width	Part number
	10 mm (0.39 in)	Z4LB-S10V2
	30 mm (1.18 in)	Z4LB-S30V2

Amplifiers on Standard Models

Amplifiers	Type	Part number
	NPN model	Z4LB-CV2
	PNP model	Z4LB-CPV2

One-Side Interruption High-Precision Models (Set Includes Sensor and Amplifier)

Emitters and receivers are not available separately.

Sensing distance	Measurement width	Part number	
		NPN models	PNP models
	10 mm (0.39 in)	Z4LB-A1040V2	Z4LB-A1040PV2
	30 mm (1.18 in)	Z4LB-A3040V2	Z4LB-A3040PV2

Note: Connecting bracket is not available separately.

■ ACCESSORIES (ORDER SEPARATELY)

Extension Cable

Application	Length	Part number
Connection between sensor and amplifier	3 m (9.84 ft)	Z49-C13 3m
	8 m (26.25 ft)	Z49-C13 8m

Note: The Extension Cable comes in a set for receiver and emitter. When ordering, specify the length required as well as the model number (i.e., Z49-C13 3 m).

Side-view Attachment for the 10-mm Beam Width Sensors Only

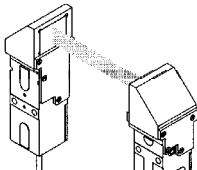
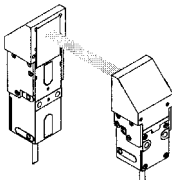
Application	For use with	Part number
Vertical beam 	10 mm Emitter	Z49-F2L
	10 mm Receiver	Z49-F2D
Horizontal beam 	10 mm Emitter	Z49-F3L
	10 mm Receiver	Z49-F3D

Specifications

Item		Standard models (separate type)		One-side Interruption high-precision models (integrated type)	
Sensors		Z4LB-S10V2	Z4LB-S30V2	---	---
Amplifiers/one-side interruption high-precision models	NPN models	Z4LB-CV2		Z4LB-A1040V2	Z4LB-A3040V2
	PNP models	Z4LB-CPV2		Z4LB-A1040PV2	Z4LB-A3040PV2
Light source (emission wavelength)		Visible-light semiconductor laser (Wavelength: 650 nm, IEC Class 1, FDA Class II)			
Measurement width		10 mm (0.39 in)	30 mm (1.18 in)	10 mm (0.39 in)	30 mm (1.18 in)
Sensing distance		0 to 300 mm (0 to 11.81 in)		40 mm fixed (1.57 in)	
Minimum sensing object		0.1 mm dia.	0.2 mm dia.	0.1 mm dia.	0.2 mm dia.
Response time (See Note 1.)		0.3 or 5 ms (switch-selectable)			
Linear output	Output voltage	1 to 5 V (output impedance: 100 Ω, allowable load resistance: 10 kΩ min.)			
	Resolution (See Note 2.)	5 μm (5 ms), 10 μm (0.3 ms)	15 μm (5 ms), 30 μm (0.3 ms)	5 μm (5 ms), 10 μm (0.3 ms)	15 μm (5 ms), 30 μm (0.3 ms)
	Linearity	---		±0.5% F.S. (See Notes 3, 5.)	
Temperature characteristic	Sensor	0.1% F.S./°C (See Notes 4, 5.)			
	Amplifier	0.02% F.S./°C (See Notes 4, 5.)			
Control outputs	Discrimination outputs HIGH, LOW (PASS, NG)	NPN models	NPN open-collector outputs: 100 mA max. at 30 VDC Residual voltage: 1.2 V max.		
		PNP models	PNP open-collector outputs: 100 mA max. at 30 VDC Residual voltage: 2.0 V max.		
Control inputs	LD OFF input Timing input Forced-zero input Bank selection input Hold reset input	NPN models	ON: 0 V short-circuited or 1.5 V max. OFF: Open (leakage current: 0.1 mA max.)		
		PNP models	ON: Power supply voltage short-circuited or power supply voltage -1.5 V max. OFF: Open (leakage current: 0.1 mA max.)		
Main functions		Measured value display, hold, bank selection, discrimination outputs, scaling			
Power supply voltage		12 to 24 VDC ±10% ripple (p-p): 10% max.			
Current consumption		200 mA max.			
Ambient illumination		3,000 lux max. (incandescent lamp)			

(Table continues on the following page. Also refer to the Table Notes found there.)

Specifications Table - continued from previous page

Item		Standard models (separate type)		One-side interruption high-precision models (integrated type)	
Sensors		Z4LB-S10V2	Z4LB-S30V2	---	---
Amplifiers/one-side interruption High-precision models	NPN models	Z4LB-CV2		Z4LB-A1040V2	Z4LB-A3040V2
	PNP models	Z4LB-CPV2		Z4LB-A1040PV2	Z4LB-A3040PV2
Ambient temperature		Operating: 0 to 50°C (32 to 122°F) Storage: -15 to 60°C (5 to 140°F) with no icing			
Ambient humidity		Operating: 35% to 85% (with no condensation) Storage: 35% to 85% (with no condensation)			
Vibration resistance	Sensor	10 to 150 Hz, half-amplitude of 0.75 mm, acceleration of 100 m/s ² max.			
	Amplifier	10 to 150 Hz, half-amplitude of 0.15 mm, acceleration of 20 m/s ² max.			
Dielectric strength	Sensor	1,000 VAC, 50/60 Hz, 1 min			
	Amplifier	300 VAC, 50/60 Hz, 1 min			
Degree of protection		IEC60529 IP40			
Connection method		Cable with connector (standard length of cable for Sensor: 2 m; standard length of cable for Amplifier: 2 m)			
Material		Sensor: Diecast zinc, Amplifier: ABS			
Weight (including package) (See Note 6.)	Sensor/ one-side interruption high- precision model	Approx. 310 g (emitter: approx. 110 g; receiver: approx. 105 g; includes 2-m cable)	Approx. 790 g (emitter: approx. 230 g; receiver: approx. 195 g; includes 2-m cable)	Approx. 610 g (Sensor: approx. 280 g; Amplifier: approx. 210 g; includes 2-m cable)	Approx. 900 g (Sensor: approx. 510 g; Amplifier: approx. 210 g; includes 2-m cable)
	Amplifier	Approx. 450 g (Amplifier: approx. 210 g; includes 2-m cable)		---	
Accessories (included)		Mounting brackets, instruction manual, laser regulation labels		Instruction manual, laser regulation labels	

Note: 1. The response time is the rising time (i.e., the time required to go from 10% to 90% of the maximum output) or falling time (i.e., the time required to go from 90% to 10% of the maximum output) for linear output when the light interruption period is rectangular in shape as shown here:

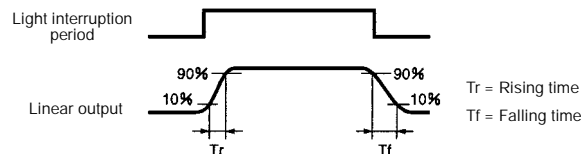

- The resolution values are conversion values for peak-to-peak linear outputs.
- Linearity: The value deviated from the ideal straight line measured at the center point between the emitter and the receiver with 5% to 95% F.S. one-side light interruption. For the Z4LB-A1040V2, the range is from 0.5 to 9.5 mm (0.019 to 0.37 in).
- The values given for temperature characteristics are typical values for the Sensor or the Amplifier alone. A typical value for the temperature characteristic when the Z49-F□□ Side-view Attachment is mounted is 0.3% F.S./°C (at sensing distance = 300 mm).
- "F.S." stands for full scale. In the case of the Z4LB-S10V2, for example, the F.S. value is 10 mm.
- The weight of the Z49-F□□ Side-view Attachment is approx. 50 g.

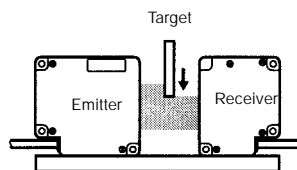

Nomenclature

■ SENSOR (10 MM BEAM WIDTH)

Z4LB-S10V2
Z4LB-A1040□V2

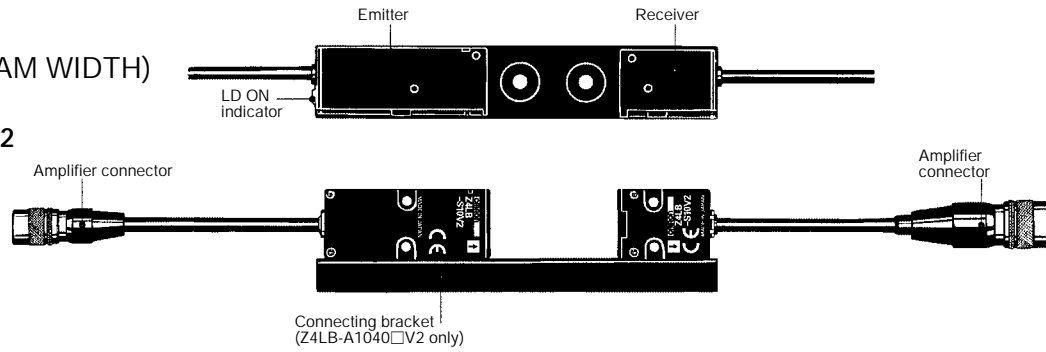

■ SENSOR (30 MM BEAM WIDTH)

Z4LB-S30V2
Z4LB-A3040□V2

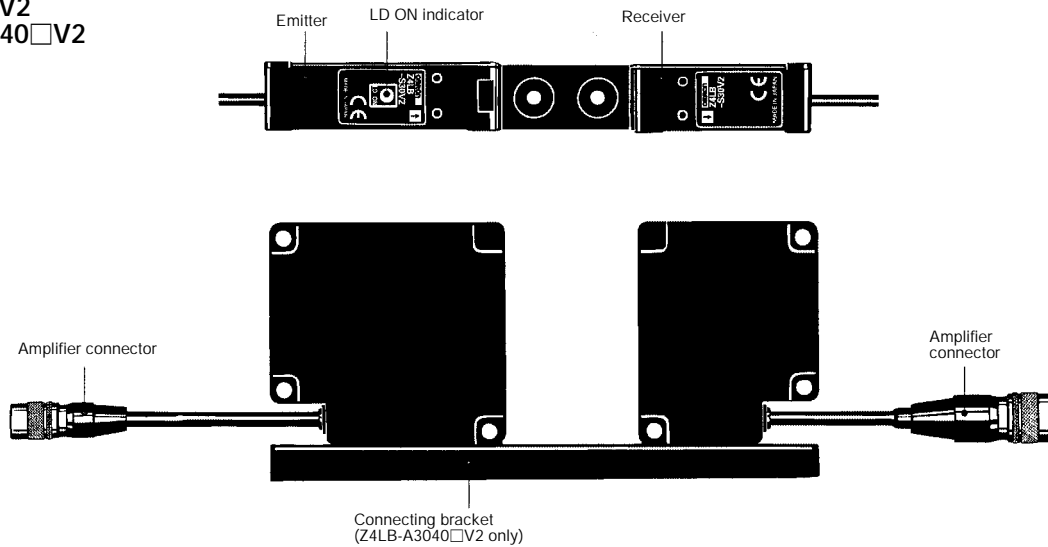

■ AMPLIFIER

Z4LB-C□V2
Z4LB-A1040□V2
Z4LB-A3040□V2

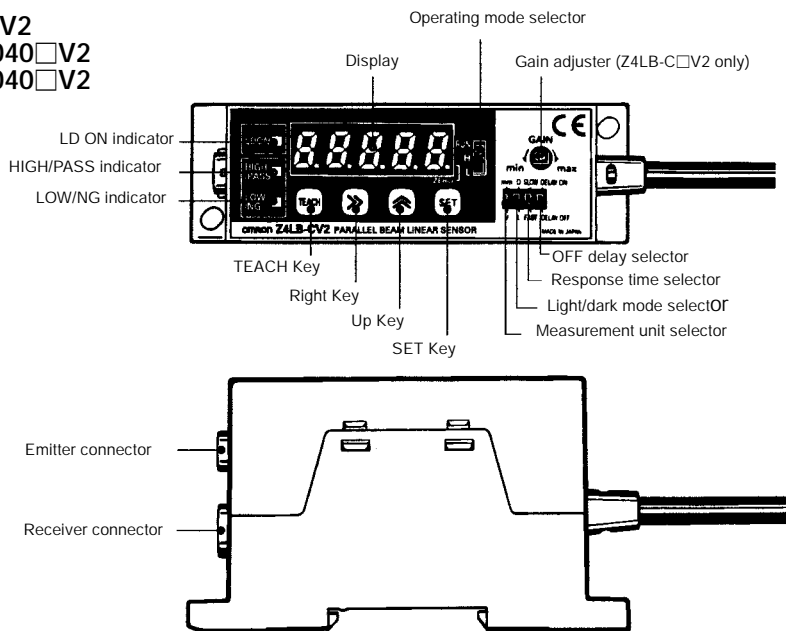

Operation

FUNCTIONS

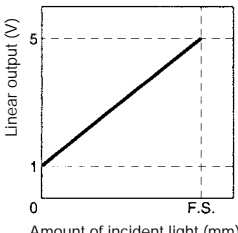
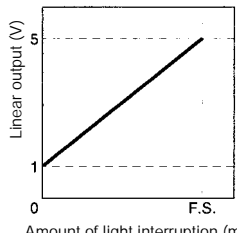
Function	Description									
Output Functions	Linear output (with light/dark mode selection function) <div style="display: flex; justify-content: space-around; margin-top: 10px;"> <div style="text-align: center;"> <p>Light mode</p>  </div> <div style="text-align: center;"> <p>Dark mode</p>  </div> </div>									
	HIGH/PASS output (with discrimination output setting and short-circuit protection functions) <p>One of the following discrimination output modes can be selected according to the application.</p> <p>HIGH/LOW Output Mode: Turns ON when measured value \leq HIGH threshold PASS/NG Output Mode: Turns ON when LOW threshold < measured value < HIGH threshold HIGH/LOW Inverted Output Mode: Turns ON when measured value \geq HIGH threshold</p> <p>The default setting is HIGH/LOW Output Mode.</p>									
	LOW/NG output (with discrimination output setting and short-circuit protection functions) <p>One of the following discrimination output modes can be selected according to the application.</p> <p>HIGH/LOW Output Mode: Turns ON when measured value \geq LOW threshold PASS/NG Output Mode: Turns ON when measured value \leq LOW threshold or measured value \geq HIGH threshold HIGH/LOW Inverted Output Mode: Turns ON when measured value \leq LOW threshold</p> <p>The default setting is HIGH/LOW Output Mode.</p>									
Input Functions	LD (laser diode) OFF input <p>Laser beams will be stopped when this input turns ON. "I doff" appears on the display, and linear output, HIGH/LOW discrimination indicator and output remain in the previous state.</p> <p>All displays except the LD ON indicator and all outputs retain the previous values.</p>									
	Forced-zero input <p>Displays the measured value as zero when the unit is set to length (mm). The value is set if forced-zero input is ON for 0.2 to 0.8 s and cleared if it is ON for 1 s or more.</p> <p>To set forced-zero or clear forced-zero, press and hold down the SET Key for 3 s while in RUN mode.</p>									
	Timing input <p>Forcibly turns OFF HIGH/PASS or LOW/NG discrimination output if this input turns ON during <i>normal</i> measurement.</p> <p>Controls sampling timing if this input turns ON during <i>hold</i> measurement.</p> <p>The default setting is <i>normal</i>.</p>									
	Bank selection input <p>The Z4LB V2 has two banks in which thresholds can be set independently.</p> <p>If the bank selection input is enabled, the thresholds to be used for judgment can be switched.</p> <p>The default setting is <i>disabled</i>.</p> <table border="1" style="margin: 10px auto; border-collapse: collapse;"> <thead> <tr> <th>Bank</th> <th>NPN type</th> <th>PNP type</th> </tr> </thead> <tbody> <tr> <td>Bank 1</td> <td>Open or connected to 12 to 24 VDC</td> <td>Open or connected to 0 V</td> </tr> <tr> <td>Bank 2</td> <td>Connected to 0 V</td> <td>Connected to 12 to 24 VDC</td> </tr> </tbody> </table>	Bank	NPN type	PNP type	Bank 1	Open or connected to 12 to 24 VDC	Open or connected to 0 V	Bank 2	Connected to 0 V	Connected to 12 to 24 VDC
	Bank	NPN type	PNP type							
Bank 1	Open or connected to 12 to 24 VDC	Open or connected to 0 V								
Bank 2	Connected to 0 V	Connected to 12 to 24 VDC								
Hold reset input <p>Resets the held value if this input turns ON during <i>hold</i> measurement.</p>										

(This table continues on the next page.)

Table continued from previous page

Function	Description						
Display Functions	LD (laser diode) ON indicator	Lights when laser beams are emitted. The Sensor and Amplifier indicators light at the same time.					
	Display (with measurement unit selection and light/dark mode selection functions)	Displays either linear output voltage (V) or length (mm) according to the measurement unit selector switch setting. If the measurement unit is set to length (mm), set the measurement width to be used. The default setting is 10 mm. The amount of incident light or light interruption can be selected using the light/dark mode selector switch.					
	HIGH/PASS indicator	Lights when HIGH/PASS discrimination output turns ON.					
	LOW/NG indicator	Lights when LOW/NG discrimination output turns ON.					
	Forced-zero indicator	Lights when the forced-zero settings are enabled in RUN mode. (displayed as the lowest decimal place)					
Adjustments	Threshold setting function						
	Direct setting	The thresholds are set to desired values by using the Right Key, Up Key, and SET Key.					
	Teaching setting	The thresholds are set to desired values by teaching. The HIGH threshold output turns ON when the HIGH threshold is equal to or below a measured value. The LOW threshold output turns ON when the LOW threshold is equal to or above a measured value.					
	Hold (refer to the following page)	Holds the display and output values. One of the following six hold methods can be selected according to the application: Peak hold, bottom hold, sample hold, peak-to-peak hold, self-peak hold, self-bottom hold. The default setting is <i>normal</i> .					
	Backup	Specifies whether to back up the forced-zero set value. If the value is to be retained after the Sensor is turned OFF, always enable the backup. The default setting is <i>enabled</i> .					
	Response time selection	The resolution changes with the response time. Select the required response time, taking the resolution into consideration.					
		<table border="1"> <thead> <tr> <th>Switch</th> <th>Response time</th> </tr> </thead> <tbody> <tr> <td>FAST</td> <td>0.3 ms</td> </tr> <tr> <td>SLOW</td> <td>5 ms</td> </tr> </tbody> </table>	Switch	Response time	FAST	0.3 ms	SLOW
Switch	Response time						
FAST	0.3 ms						
SLOW	5 ms						
Gain adjustment (for standard model only)	Adjusts the full scale of linear output and display.						
Logic	OFF delay	The HIGH/LOW discrimination outputs will have a 40-ms OFF delay if the OFF delay selector is set to ON.					

■ HOLD FUNCTIONS

Normal

Measurement is performed continuously and measurement results are displayed and output.

Peak Hold and Bottom Hold

The maximum or the minimum value while the timing input is ON is displayed, output, and held. The discrimination outputs are controlled according to the displayed value and output value.

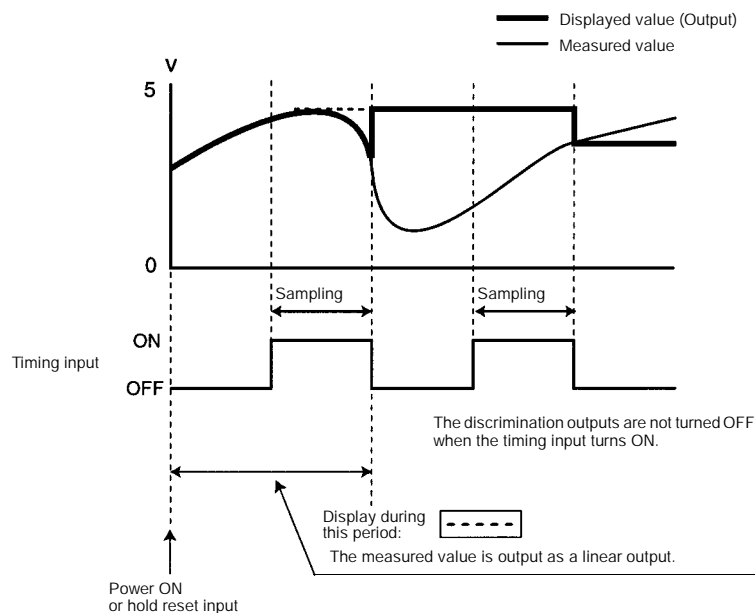

Sample Hold

The current value when the timing input turns ON is displayed, output, and held. The discrimination outputs are controlled according to the displayed value and output value.

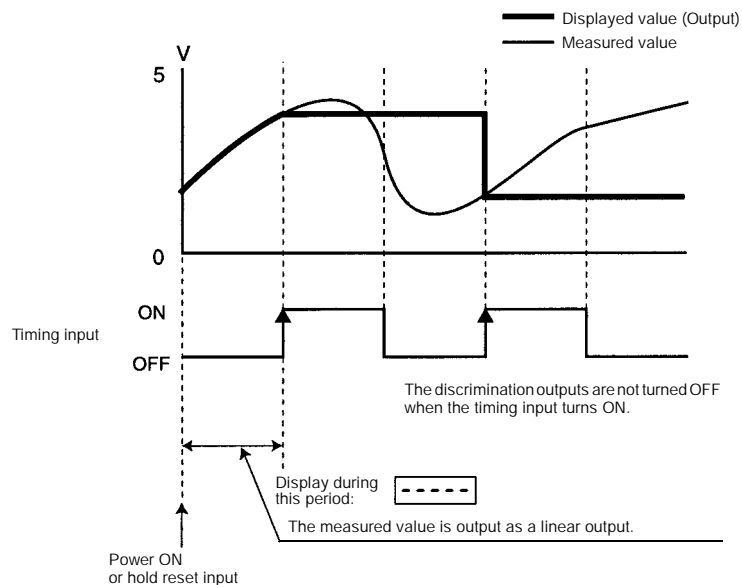

Peak-to-peak Hold

The difference between the maximum and minimum values while timing input is ON is displayed, output, and held. The discrimination outputs are controlled according to the displayed value and output value.

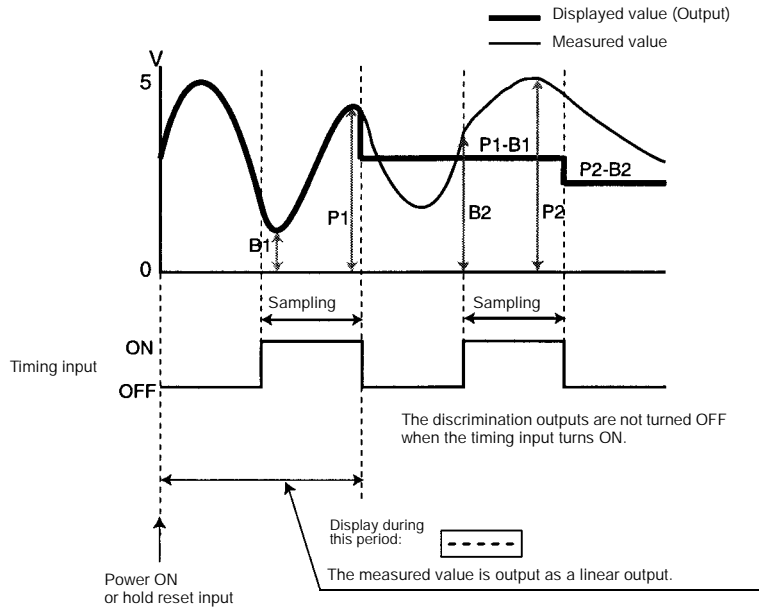

Self-peak Hold and Self-bottom Hold

The maximum value (self-peak hold) or the minimum value (self-bottom hold) while the measured value is equal to or greater than the trigger level (self-peak hold), or is equal to or smaller than the trigger level (self-bottom hold), is displayed, output, and held. The discrimination outputs are controlled according to the displayed value and output value.

Note: No sampling is performed when the timing input is ON.

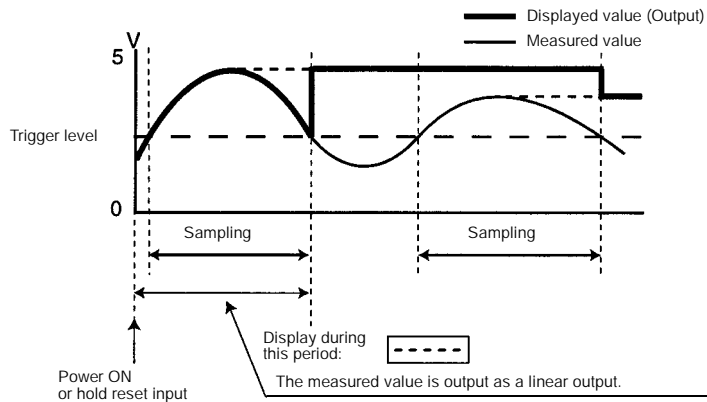

I/O STAGE CIRCUIT DIAGRAMS

NPN Models

Standard Model: Z4LB-CV2

High-precision Models: Z4LB-A□□V2

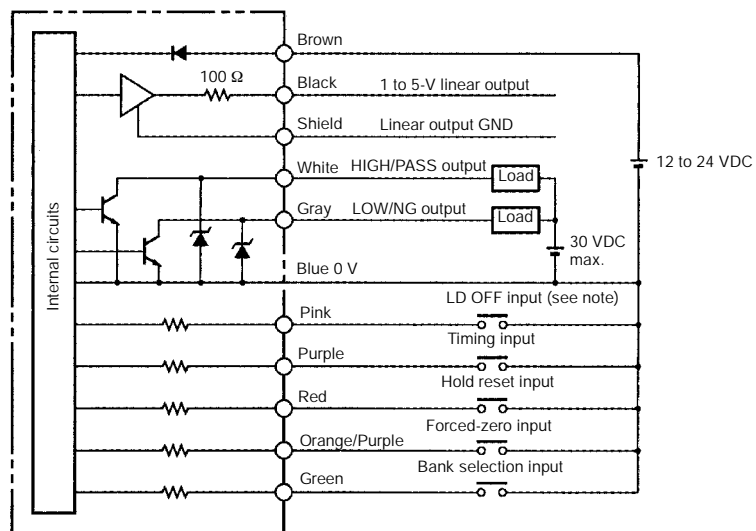

Note: LD OFF = Laser Diode off.

PNP Models

Standard Model: Z4LB-CPV2

High-precision Models: Z4LB-A□□PV2

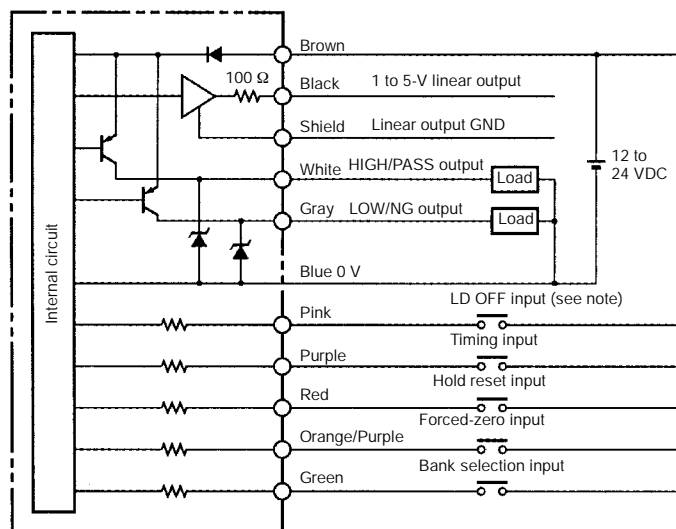

Note: LD OFF = Laser Diode off.

■ SENSOR

Z4LB-S30V2

30 mm Beam Width and
0 to 300 mm Sensing
Distance

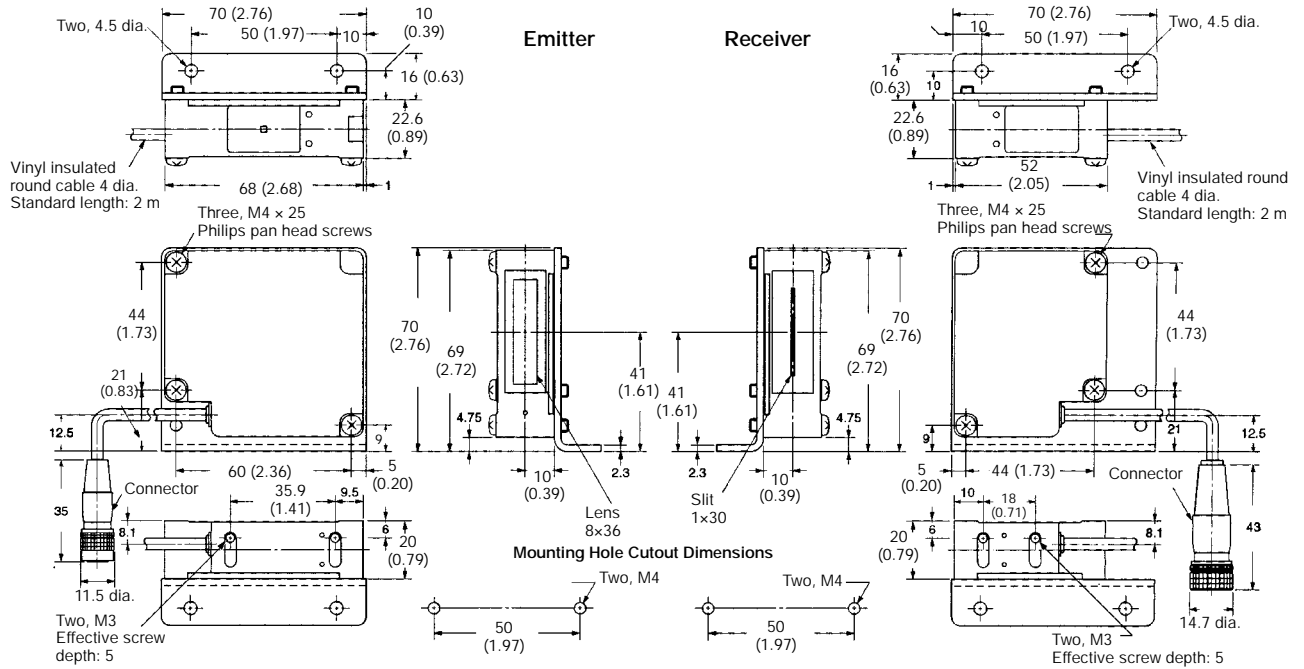
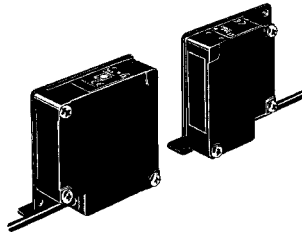

■ SENSOR

Z4LB-A3040□V2

30 mm Beam Width and
40 mm Fixed Sensing
Distance

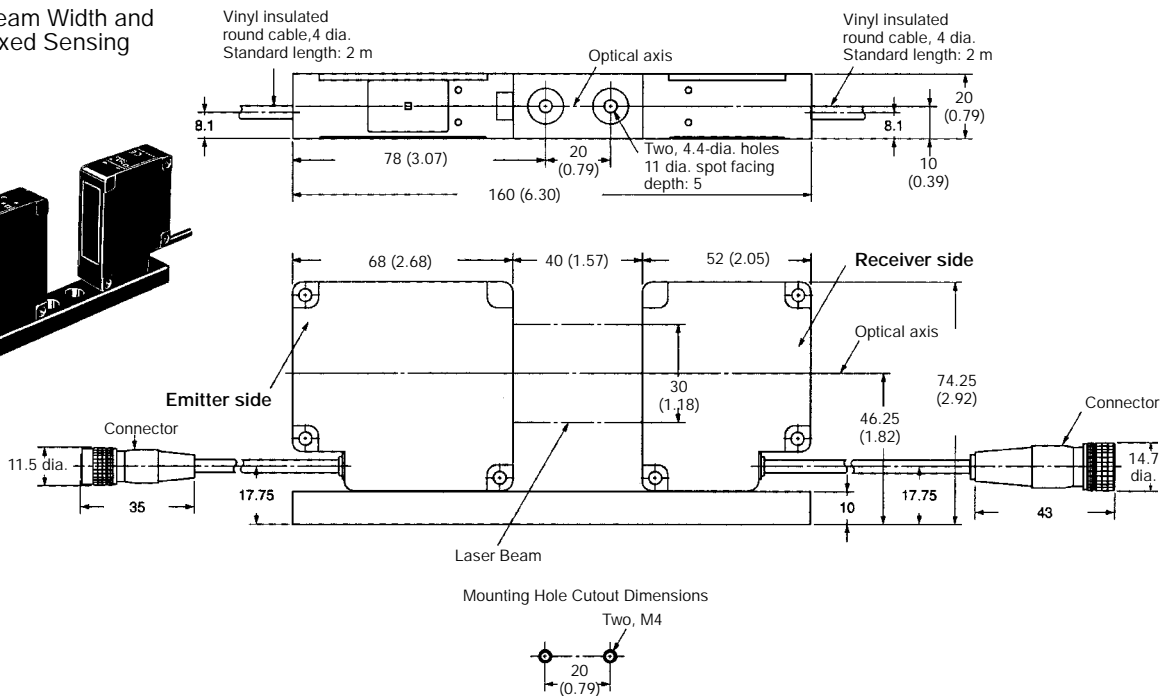
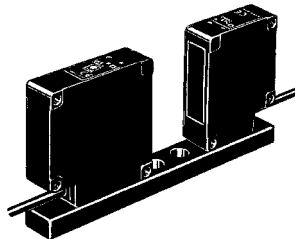

Unit: mm (inch)

AMPLIFIER

Z4LB-C□V2
Z4LB-A1040□V2
Z4LB-A3040□V2

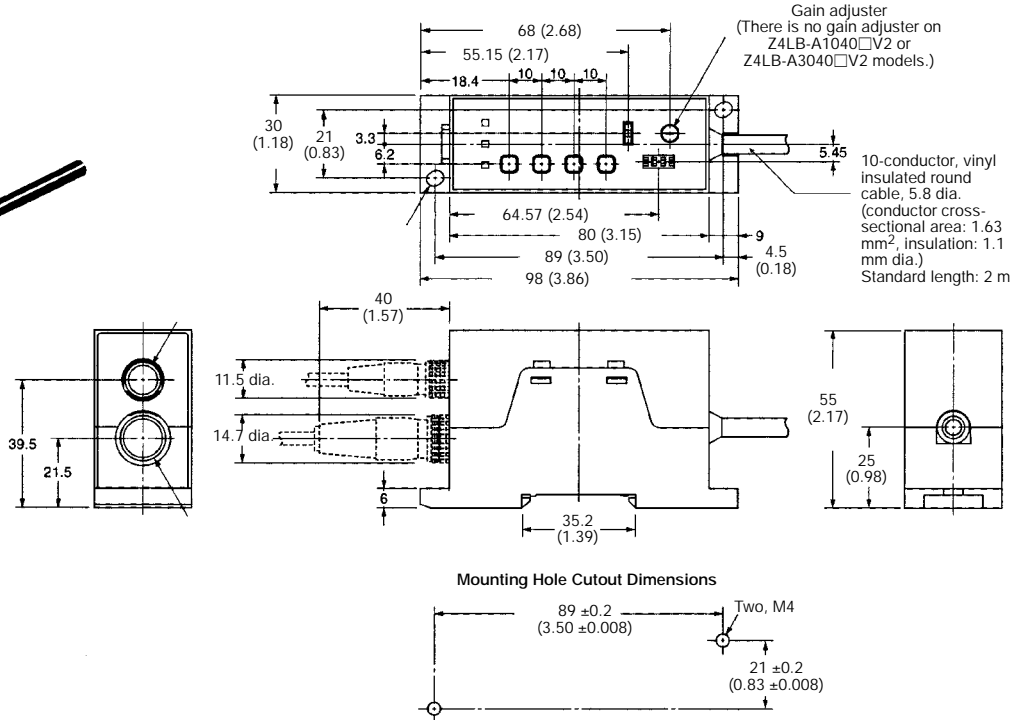
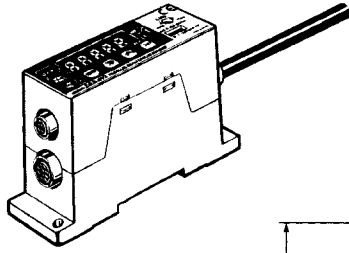

SIDE-VIEW ATTACHMENT VERTICAL BEAM

Z49-F2L
(For 10 mm Beam-Width Emitter Only)

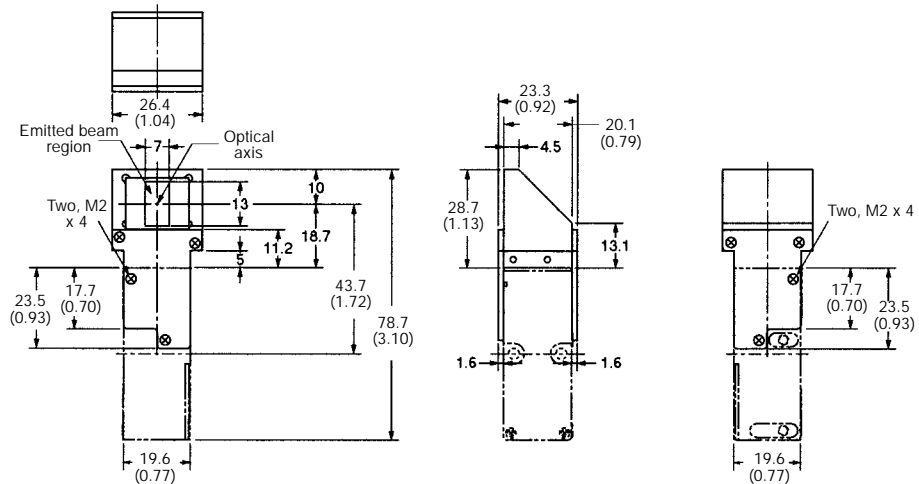

SIDE-VIEW ATTACHMENT VERTICAL BEAM

Z49-F2D
(For 10 mm Beam-Width Receiver Only)

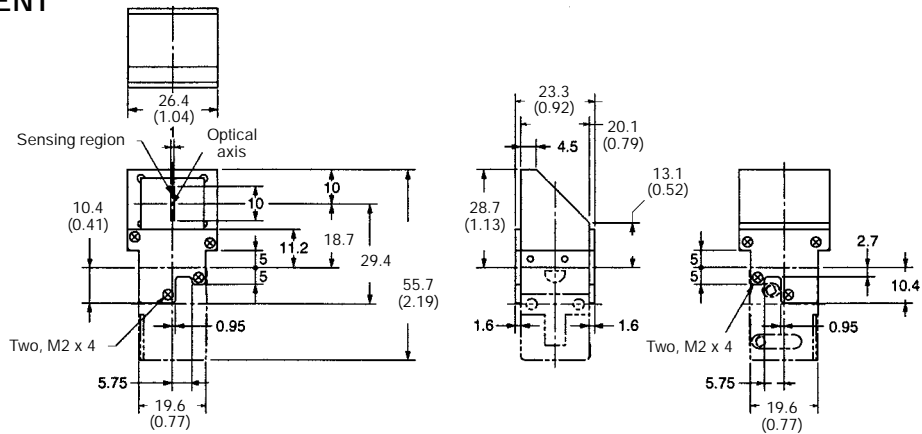

■ SIDE-VIEW ATTACHMENT HORIZONTAL BEAM

Z49-F3L

(For 10 mm Beam-Width Emitter Only)

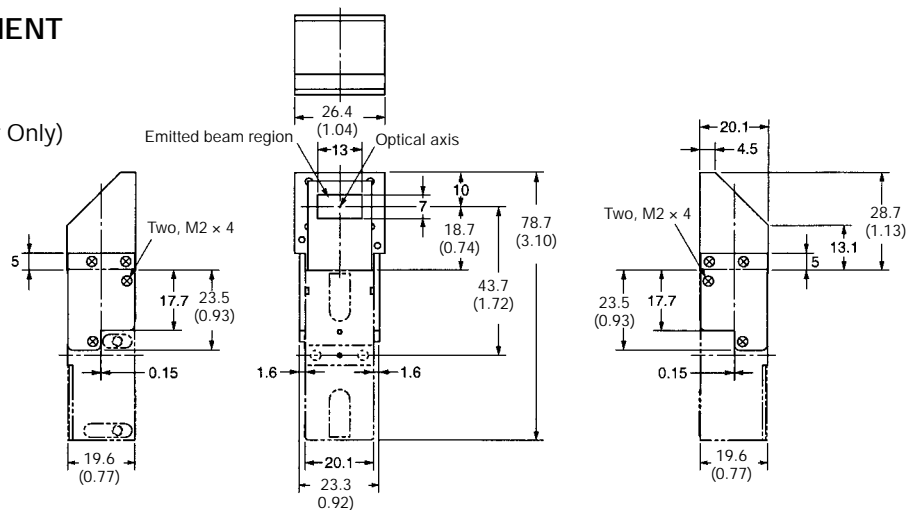

■ SIDE-VIEW ATTACHMENT HORIZONTAL BEAM

Z49-F3D

(For 10 mm Beam-Width Receiver Only)

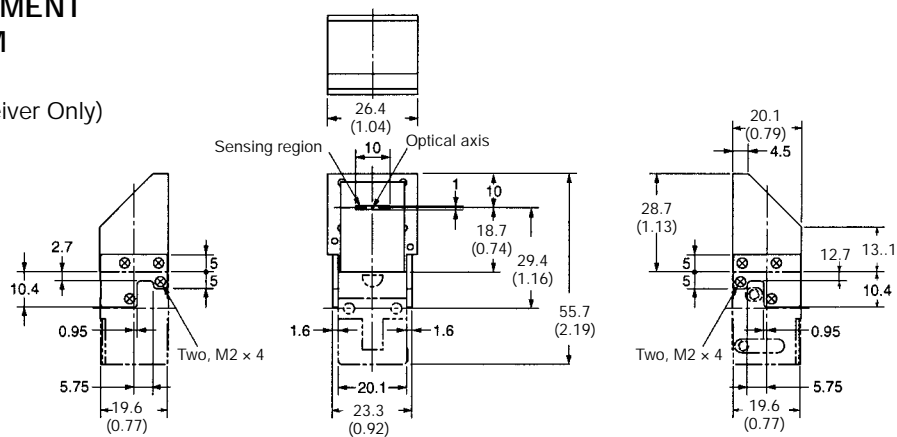

Engineering Data

LINEARITY

(WD: Distance Between Receiver and Workpiece)

Z4LB-S10V2

(Sensing Distance: 300 mm)

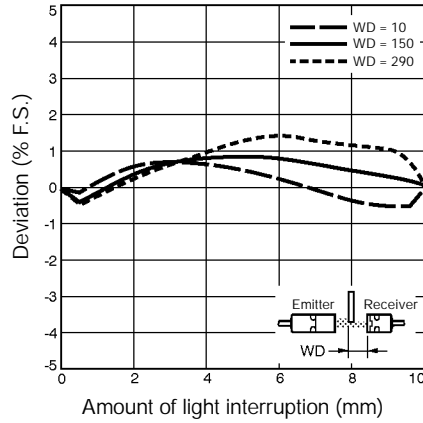

Z4LB-S30V2

(Sensing Distance: 300 mm)

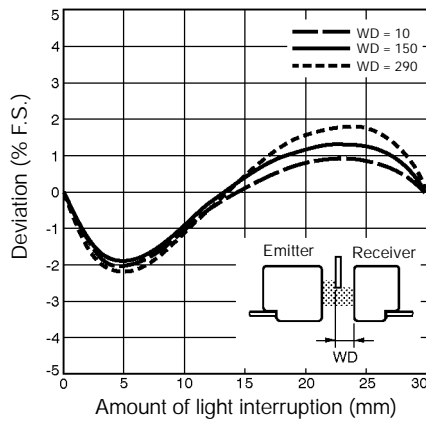

Z4LB-A1040V2

(Sensing Distance: 40 mm)

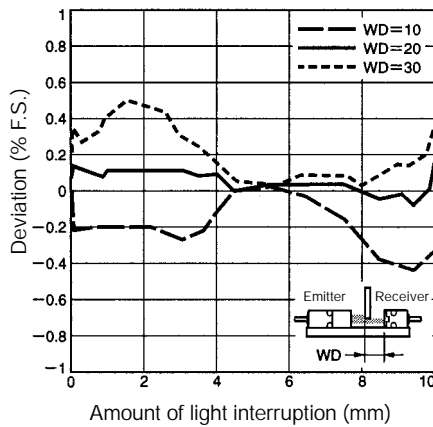

Z4LB-A3040V2

(Sensing Distance: 40 mm)

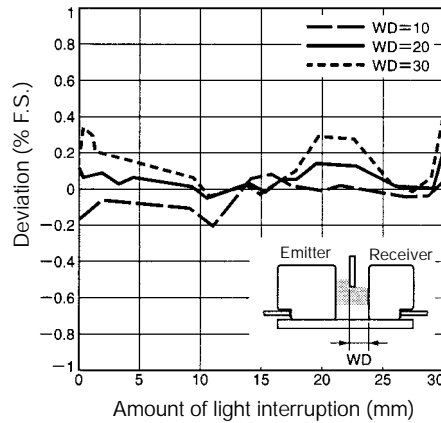

■ DEVIATION ACCORDING TO POSITION OF A ROUND ROD

(Sensing Distance: 300 mm; WD: Distance Between Receiver and Workpiece)

Z4LB-S10V2

(Diameter of Rod = 1 dia.)

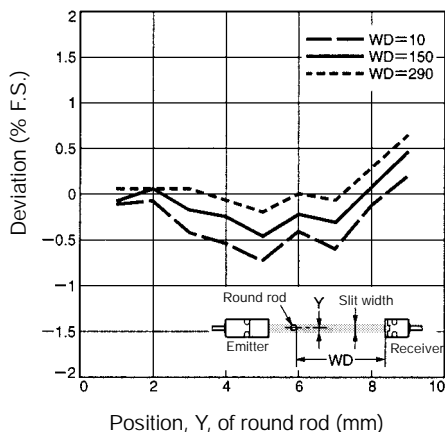

Z4LB-S30V2

(Diameter of Rod = 1 dia.)

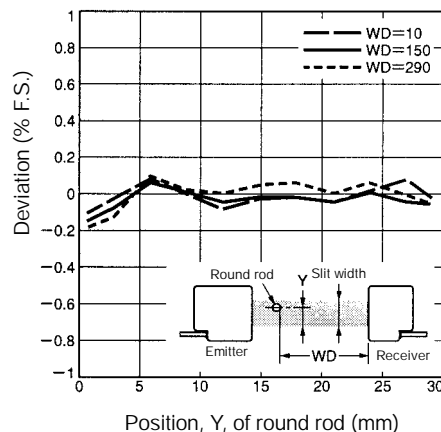

Z4LB-S10V2

(Diameter of Rod = 5 dia.)

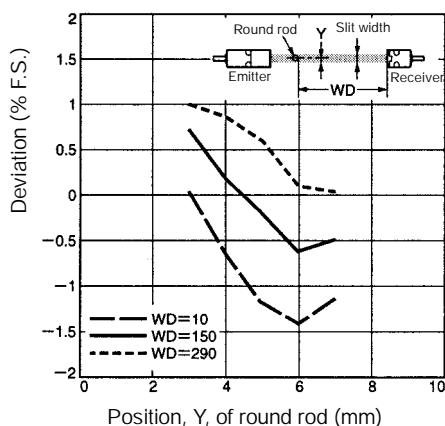

Z4LB-S30V2

(Diameter of Rod = 10 dia.)

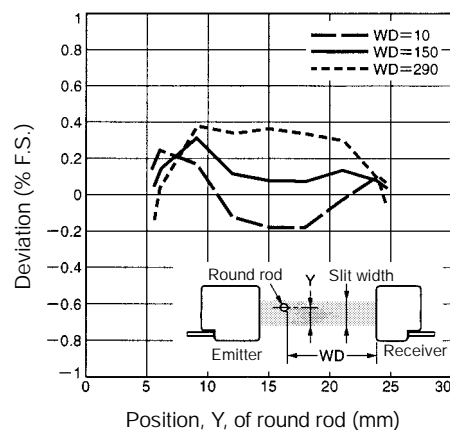

Installation

■ WIRING

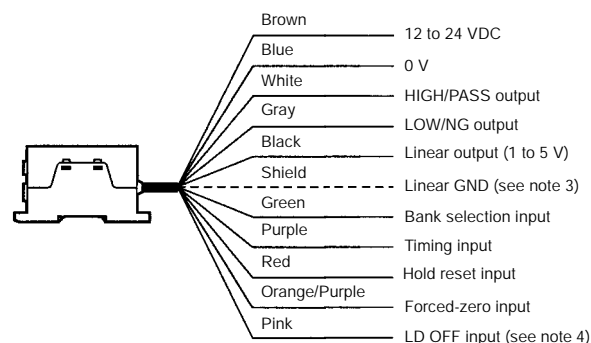

- Note:**
1. When particularly high resolutions are required, use a separate, stable power supply.
 2. Perform wiring correctly. Failure to do so may result in damage to the Sensor. In particular, ensure that the black wire for linear output does not come into contact with other wires.
 3. 0 V (blue) and linear GND (shield) are connected internally passing through a resistor. Use the blue wire (0 V) to supply power, and use the shielded wire (linear GND) together with the black wire (linear output) for linear output.

Precautions

DESIGNING THE SETUP

Compatibility

There is general compatibility between Sensors and Amplifiers for standard models. The emitters and the receivers are inspected as sets before delivery. Operation is possible using the emitters or the receivers from other sets, but in order to satisfy specifications, the serial number of the emitter and the receiver must be the same.

With high-precision models, the Sensor and the Amplifier are adjusted as a set. Use only combinations with the same serial number.

Mutual Interference

Operation is possible with two or more Sensors mounted together, but operation is not possible with two or more beams in close proximity. If the Sensor is used in this way, it may cause malfunction.

WIRING PRECAUTIONS

Wiring and Power Supply

Do not impose voltage exceeding the rated voltage, or the Sensor may be damaged.

When supplying power to the Sensor, make sure that the polarity of the power is correct, or the Sensor may be damaged.

Do not short-circuit the load supplied with open collector output, or the Sensor may be damaged.

Do not lay a power supply cable for the Z4LB V2 together with high-voltage lines or power lines to prevent interference, damage, and malfunction.

The Z49-C13 Extension cable (3 or 8 m in length) can be connected to the Sensor cable or Amplifier cable. The total length of the Sensor cable or Amplifier cable, however, must be 10 m or less. To extend the Amplifier cable, a shielded cable that is the same as that of the Amplifier cable must be used.

Use an isolation transformer for the power supply of the Z4LB V2 as shown below. Do not use an autotransformer (single-winding transformer).

Incorrect

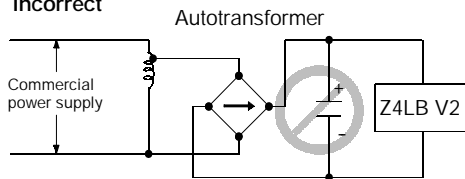

Correct

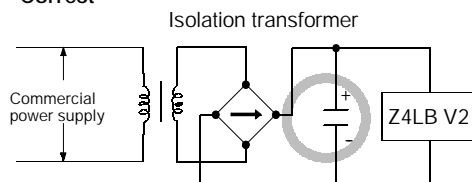

MAINTENANCE

Install the Sensor in a clean environment and keep the filter on the front panel of the Sensor free from oil and dust. If affected by oil or dust, clean the filter as follows:

1. Use a blower brush (used to clean camera lenses) to blow large dust particles from the surface. Do not blow the dust away with your mouth.
2. Use a soft cloth (for lenses) with a small amount of alcohol to remove the remaining dust.

Note: Do not use a scrubbing action when cleaning because scratches on the filter could result in the Sensor malfunctioning.

ENVIRONMENT

Do not use the Sensor in strong electromagnetic fields or in an environment where the operation of the Sensor is subject to the reflection of intense light (such as other laser beams or electric arc-welding machines.)

The Sensor may not be able to accurately detect objects of certain materials or shapes.

MOUNTING THE SIDE-VIEW ATTACHMENT

Handling Precautions

Do not apply excessive shock to the Attachment. Doing so may result in damage.

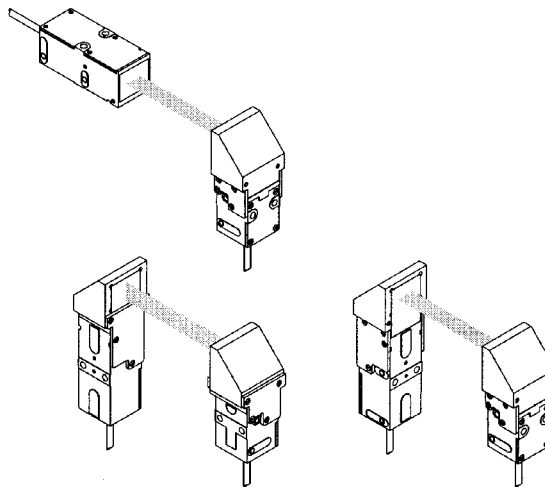

Mounting Precautions

- Do not touch any internal parts when mounting. Dirt inside the Attachment may affect the high-performance reflective mirror inside and cause malfunction.
- When mounting the Attachment, tighten the mounting screws to a torque not exceeding $0.2 \text{ N} \cdot \text{m}$.

Laser Safety

The Z4LB V2 Parallel Beam Linear Sensor, is a Class 1 Laser Product according to EN60825-1 (IEC825-1) and a Class II Laser Product according to FDA (21 CFR1040.10) (See Note).

The Z4LB V2 is meant to be built into final system equipment. Pay special attention to the following list of precautions for the safe use of the product.

Note: Europe: Class 1 of EN60825-1: 1994 = IEC825-1: 1993
U.S.A.: Class II of FDA (21 CFR1040.10)

■ USER PRECAUTIONS

1. Use this product as specified in this data sheet, or you may be exposed to hazardous laser radiation.
2. Be careful not to expose your eyes directly to the laser radiation or indirectly to laser radiation reflected from mirror or shiny surfaces.
3. To avoid exposure to hazardous laser radiation, do not displace nor remove the protective housing during operation, maintenance or during any other servicing.
4. Return the product to OMRON for all repair and servicing.
5. Observe the regulations and standards specified by the country you are in.

CLASS 1 LASER PRODUCT

■ LABEL INDICATIONS

Please attach labels, based upon your required safety regulations, as shown in the diagram below.

EN

CLASS 1 LASER PRODUCT

Note: Use of controls, adjustments, or procedures other than those specified herein may result in hazardous radiation exposure.

FDA

Z4LB-S10V2
Z4LB-A1040□V2

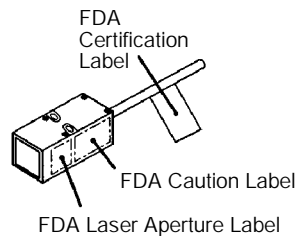

Z4LB-S30V2
Z4LB-A3040□V2

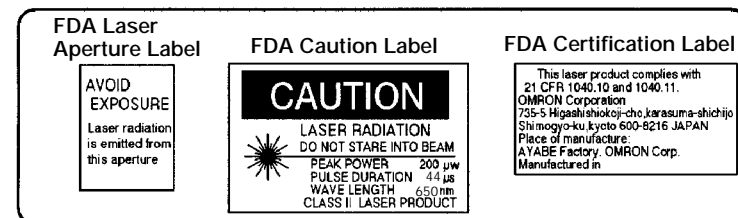
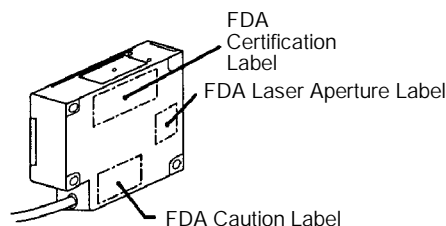

The product has been produced at OMRON Ayabe which obtained ISO9001-approval for its quality system and ISO14001-approval for its environmental management system from international certification bodies.

NOTE: DIMENSIONS SHOWN ARE IN MILLIMETERS. To convert millimeters to inches divide by 25.4.

OMRON[®]

OMRON ELECTRONICS LLC

One East Commerce Drive
Schaumburg, IL 60173

1-800-55-OMRON

OMRON ON-LINE

Global - <http://www.omron.com>
USA - <http://www.omron.com/oei>
Canada - <http://www.omron.com/oci>

OMRON CANADA, INC.

885 Milner Avenue
Scarborough, Ontario M1B 5V8

416-286-6465