

Compliance with RoHS Directive

### FEATURES

#### 1. Now even more miniature.

The new thin type cuts 35% from the thickness of the previous short type. Device installing is now easier than ever.

#### 2. Certain detection unaffected by the reflectance of the object

The sensor can provide stable detection that is not affected by the condition (color or material of the clothing) or parts (skin, hair, etc.) of the object being monitored. (Reflectance 18% to 90%). Excellent performance even when the detection surface is dirty.

#### 3. Only connecting DC power supply for operating

Built-in oscillation circuit type obviates the hitherto existing need for start signal input.

#### 4. Use in adjacent positions is possible

These sensors can be located in adjacent positions, because the timing of the external trigger signals can be adjusted so that the beam frequency of each adjacent sensor will not interfere with the other.

### APPLICATIONS

#### 1. Water-based product market

- Automatic lighting of wash basin units
- Toilets

#### 2. Stores and financial instructions

- Automatic doors
- Automatic lighting
- Cash dispensing machines
- Automatic teller machines
- Visitor detecting sensors

#### 3. Amusement market

- Automatic lighting for game display

#### 4. Medical field

- Non-contact switch

## ORDERING INFORMATION

AM

A: Thin short type MA Motion sensor

B: MA Motion sensor

Detection distance type (shape)

- 1: Short type
- 2: Middle type
- 3: Long type

Triggering function

- 1: External triggering type
- 4: Built-in oscillation circuit type (Internal trigger)

Classification by output method & mounting direction

- 0: NPN open collector/H type
- 5: NPN open collector/V type
- 6: PNP open collector/V type

Operating voltage

- 2: Free-ranging power type (6.5 to 27V DC)
- 9: 5V DC type (4.5 to 6.5V DC)

Rated detection distance

Part No.	cm inch																		
	02	03	04	05	06	07	08 (Middle type does not need 08)	09	10 (Short type does not need 10)	11	12	13	14	15	16	17	18	19	20 (Long type does not need 20)
Thin short type	—	—	—	5 1.969	—	—	—	—	10 3.937	—	—	—	—	15 5.906	—	—	—	—	—
Short type	—	—	—	5 1.969	6 2.362	7 2.756	8 3.150	9 3.543	10 3.937	—	—	—	—	—	—	—	—	—	—
Middle type	20 7.874	30 11.811	40 15.748	50 19.685	60 23.622	70 27.559	80 31.496	—	—	—	—	—	—	—	—	—	—	—	—
Long type	—	30 11.811	40 15.748	50 19.685	60 23.622	70 27.559	80 31.496	90 35.433	100 39.37	110 43.307	120 47.244	130 51.181	140 55.118	150 59.055	160 62.992	170 66.929	180 70.866	190 74.803	200 78.74

# MA Motion Sensor (AMA1, AMB1, 2, 3)

## PRODUCT TYPES

### 1. Detection distance type (distance limited)

#### 1) Thin short type (V type)

Operating voltage	Output method	Rated detection distance	Built-in oscillation circuit type		External triggering type	
			Part No.		Part No.	
4.5 to 6.5 V DC	NPN open collector output	5 cm 1.969 inch	AMA145905		AMA115905	
		10 cm 3.937 inch	AMA1459		AMA1159	
		15 cm 5.906 inch	AMA145915		AMA115915	
	PNP open collector output	5 cm 1.969 inch	AMA146905		AMA116905	
		10 cm 3.937 inch	AMA1469		AMA1169	
		15 cm 5.906 inch	AMA146915		AMA116915	

Standard packing: Carton: 20 pcs.; Case: 200 pcs.

Note: If you plan to use multiple sensors side-by-side, or you wish to keep the current consumption small, inquire for details about external trigger type, which is suitable for such applications.

#### 2) Short type (H type)

Rated operating voltage	Rated detection distance	Mounting direction: H type	
		Short type	
		Built-in oscillation circuit type	External triggering type
		Part No.	
4.5 to 6.5 V DC	5 cm 1.969 inch	AMB140905	
	6 cm 2.362 inch	AMB140906	
	7 cm 2.756 inch	AMB140907	
	8 cm 3.150 inch	AMB140908	
	9 cm 3.543 inch	AMB140909	
	10 cm 3.937 inch	AMB1409	
6.5 to 27 V DC	5 cm 1.969 inch	AMB140205	
	6 cm 2.362 inch	AMB140206	
	7 cm 2.756 inch	AMB140207	
	8 cm 3.150 inch	AMB140208	
	9 cm 3.543 inch	AMB140209	
	10 cm 3.937 inch	AMB1402	

Standard packing: Carton: 20 pcs.; Case: 200 pcs.

Note: If you plan to use multiple sensors side-by-side, or you wish to keep the current consumption small, inquire for details about external trigger type, which is suitable for such applications.

#### 3) Middle type (H type)

Rated operating voltage	Rated detection distance	Mounting direction: H type	
		Middle type	
		Built-in oscillation circuit type	External triggering type
		Part No.	
4.5 to 6.5 V DC	20 cm 7.874 inch	AMB240902	
	30 cm 11.811 inch	AMB240903	
	40 cm 15.748 inch	AMB240904	
	50 cm 19.685 inch	AMB240905	
	60 cm 23.622 inch	AMB240906	
	70 cm 27.559 inch	AMB240907	
	80 cm 31.496 inch	AMB2409	
6.5 to 27 V DC	20 cm 7.874 inch	AMB240202	
	30 cm 11.811 inch	AMB240203	
	40 cm 15.748 inch	AMB240204	
	50 cm 19.685 inch	AMB240205	
	60 cm 23.622 inch	AMB240206	
	70 cm 27.559 inch	AMB240207	
	80 cm 31.496 inch	AMB2402	

Standard packing: Carton: 20 pcs.; Case: 200 pcs.

Note: If you plan to use multiple sensors side-by-side, or you wish to keep the current consumption small, inquire for details about external trigger type, which is suitable for such applications.

# MA Motion Sensor (AMA1, AMB1, 2, 3)

## 4) Long type

Rated operating voltage	Rated detection distance	Mounting direction: H type		Mounting direction: V type	
		Long type			
		Built-in oscillation circuit type	External triggering type	Built-in oscillation circuit type	External triggering type
		Part No.	Part No.	Part No.	Part No.
4.5 to 6.5 V DC	30 cm 11.811 inch	AMB340903	AMB310903	AMB345903	AMB315903
	40 cm 15.748 inch	AMB340904	AMB310904	AMB345904	AMB315904
	50 cm 19.685 inch	AMB340905	AMB310905	AMB345905	AMB315905
	60 cm 23.622 inch	AMB340906	AMB310906	AMB345906	AMB315906
	70 cm 27.559 inch	AMB340907	AMB310907	AMB345907	AMB315907
	80 cm 31.496 inch	AMB340908	AMB310908	AMB345908	AMB315908
	90 cm 35.433 inch	AMB340909	AMB310909	AMB345909	AMB315909
	100 cm 39.370 inch	AMB340910	AMB310910	AMB345910	AMB315910
	110 cm 43.307 inch	AMB340911	AMB310911	AMB345911	AMB315911
	120 cm 47.244 inch	AMB340912	AMB310912	AMB345912	AMB315912
	130 cm 51.181 inch	AMB340913	AMB310913	AMB345913	AMB315913
	140 cm 55.118 inch	AMB340914	AMB310914	AMB345914	AMB315914
	150 cm 59.055 inch	AMB340915	AMB310915	AMB345915	AMB315915
	160 cm 62.992 inch	AMB340916	AMB310916	AMB345916	AMB315916
	170 cm 66.929 inch	AMB340917	AMB310917	AMB345917	AMB315917
	180 cm 70.866 inch	AMB340918	AMB310918	AMB345918	AMB315918
	190 cm 74.803 inch	AMB340919	AMB310919	AMB345919	AMB315919
200 cm 78.740 inch	AMB3409	AMB3109	AMB3459	AMB3159	
6.5 to 27 V DC	30 cm 11.811 inch	AMB340203	AMB310203	AMB345203	AMB315203
	40 cm 15.748 inch	AMB340204	AMB310204	AMB345204	AMB315204
	50 cm 19.685 inch	AMB340205	AMB310205	AMB345205	AMB315205
	60 cm 23.622 inch	AMB340206	AMB310206	AMB345206	AMB315206
	70 cm 27.559 inch	AMB340207	AMB310207	AMB345207	AMB315207
	80 cm 31.496 inch	AMB340208	AMB310208	AMB345208	AMB315208
	90 cm 35.433 inch	AMB340209	AMB310209	AMB345209	AMB315209
	100 cm 39.370 inch	AMB340210	AMB310210	AMB345210	AMB315210
	110 cm 43.307 inch	AMB340211	AMB310211	AMB345211	AMB315211
	120 cm 47.244 inch	AMB340212	AMB310212	AMB345212	AMB315212
	130 cm 51.181 inch	AMB340213	AMB310213	AMB345213	AMB315213
	140 cm 55.118 inch	AMB340214	AMB310214	AMB345214	AMB315214
	150 cm 59.055 inch	AMB340215	AMB310215	AMB345215	AMB315215
	160 cm 62.992 inch	AMB340216	AMB310216	AMB345216	AMB315216
	170 cm 66.929 inch	AMB340217	AMB310217	AMB345217	AMB315217
	180 cm 70.866 inch	AMB340218	AMB310218	AMB345218	AMB315218
	190 cm 74.803 inch	AMB340219	AMB310219	AMB345219	AMB315219
200 cm 78.740 inch	AMB3402	AMB3102	AMB3452	AMB3152	

Standard packing: Carton: 20 pcs.; Case: 200 pcs.

Note: If you plan to use multiple sensors side-by-side, or you wish to keep the current consumption small, inquire for details about external trigger type, which is suitable for such applications.

## RATING

### 1. Detection performance

1) Thin short type (Measuring conditions: ambient temp.: 25°C 77°F; operating voltage: 5 V DC)

Items		Thin short type			Measured conditions
		5 cm 1.969 inch	10 cm 3.937 inch	15 cm 3.937 inch	
Rated detection distance	Minimum	45 mm	90 mm	135 mm	with a standard reflection board*1
	Typical	1.772 inch 50 mm	3.543 inch 100 mm	5.315 inch 150 mm	
	Maximum	1.969 inch 55 mm 2.165 inch	3.937 inch 110 mm 4.331 inch	5.906 inch 165 mm 6.496 inch	
Measuring tolerance	Typical	10%	25%	35%	Reflection rate: 90 to 18%
Usable ambient brightness (Resistance to ambient light)*2	Brightness of sensor surface	30,000 lx			See the drawing (Fig. 1) on the next page.
	Brightness of reflection surface	30,000 lx			

Notes: \*1. Ambient brightness: 500 lx

\*2. Install so that light from direct light sources does not enter the sensor (within 30° of the sensor light beam).  
Indicates brightness detectable enough for sensor operation.

# MA Motion Sensor (AMA1, AMB1, 2, 3)

2) Short type (Measuring conditions: ambient temp.: 25°C 77°F; operating voltage: 5 V DC type 5V, Free-ranging power type 24V DC)

Items		Short type*1						Measured conditions
		5 cm 1.969 inch	6 cm 2.362 inch	7 cm 2.756 inch	8 cm 3.150 inch	9 cm 3.543 inch	10 cm 3.937 inch	
Rated detection distance	Minimum	45 mm 1.772 inch	54 mm 2.126 inch	63 mm 2.480 inch	72 mm 2.835 inch	81 mm 3.189 inch	90 mm 3.543 inch	with a standard reflection board
	Typical	50 mm 1.969 inch	60 mm 3.362 inch	70 mm 2.756 inch	80 mm 3.150 inch	90 mm 3.543 inch	100 mm 3.937 inch	
	Maximum	55 mm 2.165 inch	66 mm 2.598 inch	77 mm 3.031 inch	88 mm 3.465 inch	99 mm 3.898 inch	110 mm 4.331 inch	
Measuring tolerance	Typical	10%		15%	20%		25%	Reflection rate: 90 to 18%
Usable ambient brightness (Resistance to ambient light)*2	Brightness of sensor surface	Maximum 30,000 lx						See the drawing (Fig. 1) on the next page.
	Brightness of reflection surface	Maximum 30,000 lx						

Notes: \*1. After receipt of order, average rated detection distance to 15 cm 5.906 inch is possible. Please inquire.

\*2. Install so that light from direct light sources does not enter the sensor (within 30° of the sensor light beam).

3) Middle type (Measuring conditions: ambient temp.: 25°C 77°F; operating voltage: 5 V DC type 5V, Free-ranging power type 24V DC)

Items		Middle type*1						Measured conditions	
		20 cm 7.874 inch	30 cm 11.811 inch	40 cm 15.748 inch	50 cm 19.685 inch	60 cm 23.622 inch	70 cm 27.559 inch		80 cm 31.496 inch
Rated detection distance	Minimum	190 mm 7.480 inch	285 mm 11.220 inch	380 mm 14.961 inch	475 mm 18.701 inch	570 mm 22.441 inch	665 mm 26.181 inch	760 mm 29.921 inch	with a standard reflection board
	Typical	200 mm 7.874 inch	300 mm 11.811 inch	400 mm 15.748 inch	500 mm 19.685 inch	600 mm 23.622 inch	700 mm 27.559 inch	800 mm 31.496 inch	
	Maximum	210 mm 8.268 inch	315 mm 12.402 inch	420 mm 16.535 inch	525 mm 20.669 inch	630 mm 24.803 inch	735 mm 28.937 inch	840 mm 33.071 inch	
Measuring tolerance	Typical	3%			5%		10%		Reflection rate: 90 to 18%
Usable ambient brightness (Resistance to ambient light)*2	Brightness of sensor surface	Maximum 30,000 lx						See the drawing (Fig. 1) on the next page.	
	Brightness of reflection surface	Maximum 30,000 lx							

Notes: \*1. After receipt of order, average rated detection distance to 110 cm 43.307 inch is possible. Please inquire.

\*2. Install so that light from direct light sources does not enter the sensor (within 30° of the sensor light beam).

4) Long type (Measuring conditions: ambient temp.: 25°C 77°F; operating voltage: 5 V DC type 5V, Free-ranging power type 24V DC)

Items		Long type									Measured conditions
		30 cm 11.811 inch	40 cm 15.748 inch	50 cm 19.685 inch	60 cm 23.622 inch	70 cm 27.559 inch	80 cm 31.496 inch	90 cm 35.433 inch	100 cm 39.37 inch	110 cm 43.307 inch	
Rated detection distance	Minimum	285 mm 11.220 inch	380 mm 14.961 inch	475 mm 18.701 inch	570 mm 22.441 inch	665 mm 26.181 inch	760 mm 29.921 inch	855 mm 33.661 inch	950 mm 37.402 inch	1045 mm 41.142 inch	with a standard reflection board
	Typical	300 mm 11.811 inch	400 mm 15.748 inch	500 mm 19.685 inch	600 mm 23.622 inch	700 mm 27.559 inch	800 mm 31.496 inch	900 mm 34.433 inch	1000 mm 39.37 inch	1100 mm 43.307 inch	
	Maximum	315 mm 12.402 inch	420 mm 16.535 inch	525 mm 20.669 inch	630 mm 24.803 inch	735 mm 28.937 inch	840 mm 33.071 inch	945 mm 37.205 inch	1050 mm 41.339 inch	1155 mm 45.472 inch	
Measuring tolerance	Typical	3%					5%				Reflection rate: 90 to 18%
Usable ambient brightness (Resistance to ambient light)*	Brightness of sensor surface	Maximum 30,000 lx									See the drawing (Fig. 1) on the next page.
	Brightness of reflection surface	Maximum 30,000 lx									

Items		Long type								Measured conditions	
		120 cm 47.244 inch	130 cm 51.181 inch	140 cm 55.118 inch	150 cm 59.055 inch	160 cm 62.992 inch	170 cm 66.929 inch	180 cm 70.866 inch	190 cm 74.803 inch		200 cm 78.74 inch
Rated detection distance	Minimum	1140 mm 44.882 inch	1235 mm 48.622 inch	1330 mm 52.362 inch	1425 mm 56.102 inch	1520 mm 59.842 inch	1615 mm 63.583 inch	1710 mm 67.323 inch	1805 mm 71.063 inch	1900 mm 74.803 inch	with a standard reflection board
	Typical	1200 mm 47.244 inch	1300 mm 51.181 inch	1400 mm 55.118 inch	1500 mm 59.055 inch	1600 mm 62.992 inch	1700 mm 66.929 inch	1800 mm 70.866 inch	1900 mm 74.803 inch	2000 mm 78.74 inch	
	Maximum	1260 mm 49.606 inch	1365 mm 53.740 inch	1470 mm 57.874 inch	1575 mm 62.008 inch	1680 mm 66.142 inch	1785 mm 70.275 inch	1890 mm 74.409 inch	1995 mm 78.543 inch	2100 mm 82.677 inch	
Measuring tolerance	Typical	5%	10%				15%				Reflection rate: 90 to 18%
Usable ambient brightness (Resistance to ambient light)*	Brightness of sensor surface	Maximum 30,000 lx								See the drawing (Fig. 1) on the next page.	
	Brightness of reflection surface	Maximum 30,000 lx									

Note: \* Install so that light from direct light sources does not enter the sensor (within 30° of the sensor light beam).

# MA Motion Sensor (AMA1, AMB1, 2, 3)

- For thin short type:  
Standard reflection board: 150 mm 5.906 inch square area,  
90% reflection rate.
- For short type:  
Standard reflection board: 100 mm 3.937 inch square area,  
90% reflection rate.
- For middle type:  
Standard reflection board: 200 mm 7.874 inch square area,  
90% reflection rate.
- For long type:  
Standard reflection board: 500 mm 19.685 inch square area,  
90% reflection rate.

Notes: 1. Detecting an object within the maximum preset detection distance.

$$2. \text{Distance deviation} = \frac{a-b}{a} \times 100 (\%)$$

(a: detection distance of detection target with reflectance of 90%.  
b: detection distance of standard detection target with reflectance of 18%.)

<Fig. 1>

[Brightness of sensor surface]

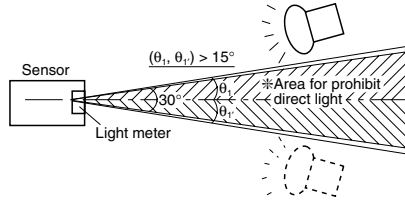

Note: Light from direct light sources (sunlight, strobe light, inverter illumination, reflected light from glass or mirrors etc.) that enters the sensor from within the prohibited range can cause the sensor to operate erroneously.

[Brightness of reflection surface]

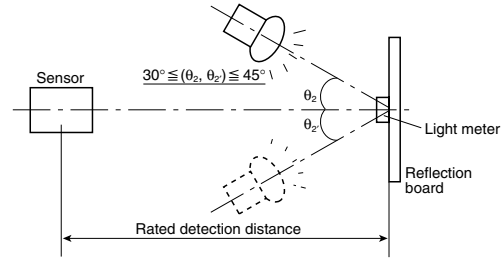

## 2. Absolute maximum rating (Measuring condition: ambient temp.: 25°C 77°F)

Items	Type	Absolute maximum rating			
		Built-in oscillation circuit type		External triggering type	
		5 V DC type	Free-ranging power type	5 V DC type	Free-ranging power type
Power supply voltage		-0.3 to 8 V DC	-0.3 to 30 V DC	-0.3 to 8 V DC	-0.3 to 30 V DC
Output dielectric strength		30 V		30 V	
Output flow current		100 mA		10 mA*	
Usable ambient temperature		-25 to +75°C +5 to +131°F (No freezing)		-25 to +75°C +5 to +131°F (No freezing)	
Storage temperature		-30 to +85°C -4 to +176°F		-30 to +85°C -4 to +176°F	

Note: \* Thin short type is only: 100 mA

## 3. Electrical characteristics

(Measuring conditions: ambient temp.: 25°C 77°F; operating voltage: 5 V DC type =5V DC, free-ranging power type =24V DC)

### 1) Built-in oscillation circuit type

Items	Symbol	Thin short type*		Short type	Middle type	Long type	Measured conditions
		NPN output type	PNP output type				
Rated operating voltage	Minimum	5V DC type: 4.5V/Free-ranging power type: 6.5V					
	Typical	—					
	Maximum	5V DC type: 6.5V/Free-ranging power type: 27V					
Average current consumption (I <sub>out</sub> = 0 mA)	No detection	Minimum	—				
		Typical	4.5mA	5V DC type: 4.5mA/Free-ranging power type: 5.6mA			
		Maximum	6.2mA	5V DC type: 6.2mA/Free-ranging power type: 7.8mA			
	Detection	Minimum	—				
		Typical	7.0mA	11.0mA	5V DC type: 7.0mA/Free-ranging power type: 9.1mA		
		Maximum	11.2mA	15.2mA	5V DC type: 11.2mA/Free-ranging power type: 14.2mA		
Measuring cycle	Minimum	T	8ms/cycle				
Output characteristics	Remain voltage	Maximum	V <sub>r</sub>	1 V DC	1.2 V DC	1 V DC	I <sub>t</sub> = 100 mA
	Leakage current	Maximum	I <sub>l</sub>	5μA		3μA	V = 30V

Note: \* The thin short type is only available for 5V DC.

# MA Motion Sensor (AMA1, AMB1, 2, 3)

2) External triggering type (trigger conditions: trigger pulse width = 20μs and trigger synchronization = 5ms)

Items		Symbol	Thin short type Note 1		Short type	Middle type	Long type	Measured conditions			
			NPN output type	PNP output type							
Rated operating voltage		Minimum	5V DC type: 4.5V/Free-ranging type: 6.5V								
		Typical	—								
		Maximum	5V DC type: 6.5V/Free-ranging type: 27V								
Average current consumption		Output OFF		Minimum	—			Note 2: *b			
				Typical	0.1m	5V DC type: 0.1mA/Free-ranging type: 1.0mA					
				Maximum	0.3m	5V DC type: 0.3mA/Free-ranging type: 1.8mA					
		Output ON		Minimum	—			Note 2: *d			
				Typical	2.6mA	6.7mA	5V DC type: 0.5mA/Free-ranging type: 1.4mA				
				Maximum	6.6mA	9.6mA	5V DC type: 3.4mA/Free-ranging type: 4.5mA				
		With trigger input		Output OFF		Minimum	—			Note 2: *a	
						Typical	2.2mA	5V DC type: 2.2mA/Free-ranging type: 3.1mA			
						Maximum	6.2mA	5V DC type: 6.2mA/Free-ranging type: 7.2mA			
				Output ON		Minimum	—			Note 2: *c	
						Typical	4.2mA	6.2mA	5V DC type: 2.4mA/Free-ranging type: 3.3mA		
						Maximum	8.2mA	12.5mA	5V DC type: 8.2mA/Free-ranging type: 9.3mA		
Measuring cycle (Trigger interval)		Minimum	Tt	5ms/cycle							
External trigger		Pulse width		Minimum	20μs			Half off the distance period			
				Maximum	1/2Tt						
		Level		Maximum	V <sub>TL</sub>	0.8V					
				Minimum	V <sub>TH</sub>	3V					
Response performance: time from trigger pulse fall to detection output		Maximum	Tr	5ms							
Output characteristics		Remain voltage	Maximum	Vr	1 V DC	1.2 V DC	1 V	I = 10 mA			
		Leakage current	Maximum	II	5μA		3μA		V = 30 mA		

Notes: 1. The thin short type is only available for 5V DC.

2. The ratio between the 4 operating modes (\*a to \*d) depends on the external trigger period and detector time, and the current consumption corresponds with this varying ratio.

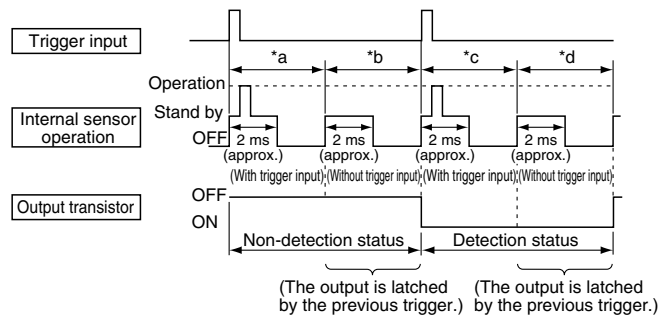

3. A high level is established in the open state due to pull-up by the internal circuit. (Refer to the connector wiring diagram.)

4. The output transistor is open collector.

The output transistor is turned ON by the sensor detection status and turned OFF by its non-detection status.

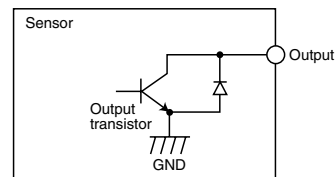

Detection status: output transistor ON  
Non-detection status: output transistor OFF

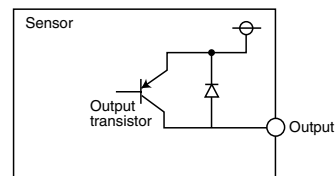

Detection status: output transistor ON  
Non-detection status: output transistor OFF

## TIMING CHART

### 1. Built-in oscillation circuit type

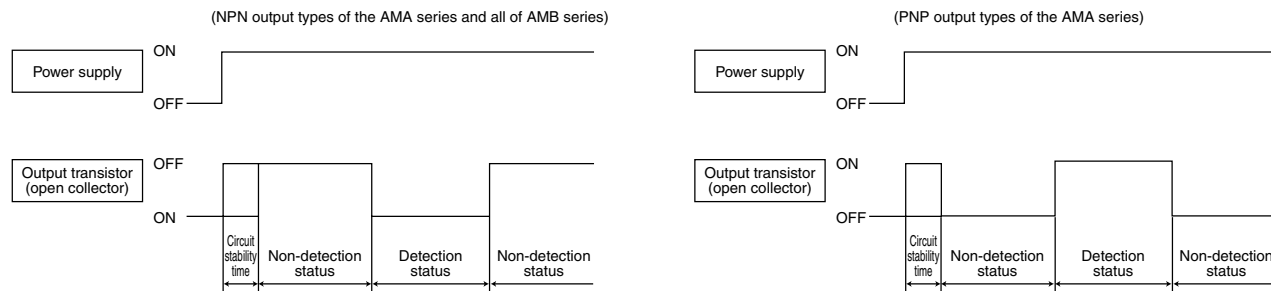

Notes: 1. Circuit stability time : Max. 12 ms

2. During the time taken for the circuit to stabilize after the power is turned on, the ON/OFF status of the output transistor is not determined by whether the sensor is in the detection status or non-detection status.

# MA Motion Sensor (AMA1, AMB1, 2, 3)

## 2. External triggering type

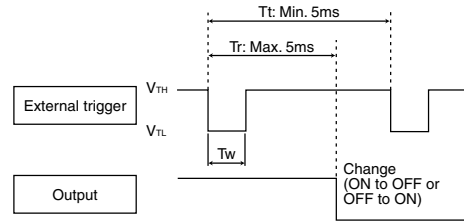
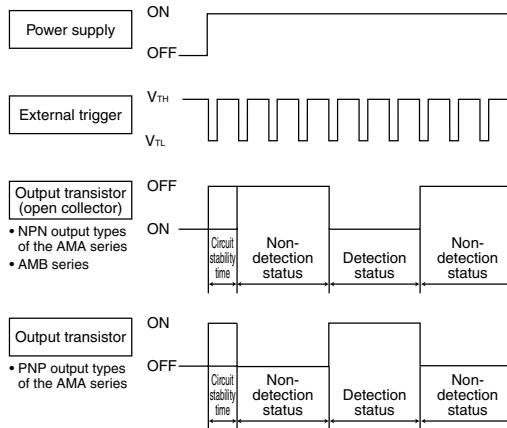

Note: The sensor recognizes at the  $V_{TH} \rightarrow V_{TL}$  edge of an external trigger that the external trigger has been input.

- Notes: 1. Circuit stability time: Max. 12 ms  
 2. During the time taken for the circuit to stabilize after the power is turned on, the ON/OFF status of the output transistor is not determined by whether the sensor is in the detection status or non-detection status.

## HOW TO USE

### 1. Wiring diagram of connector

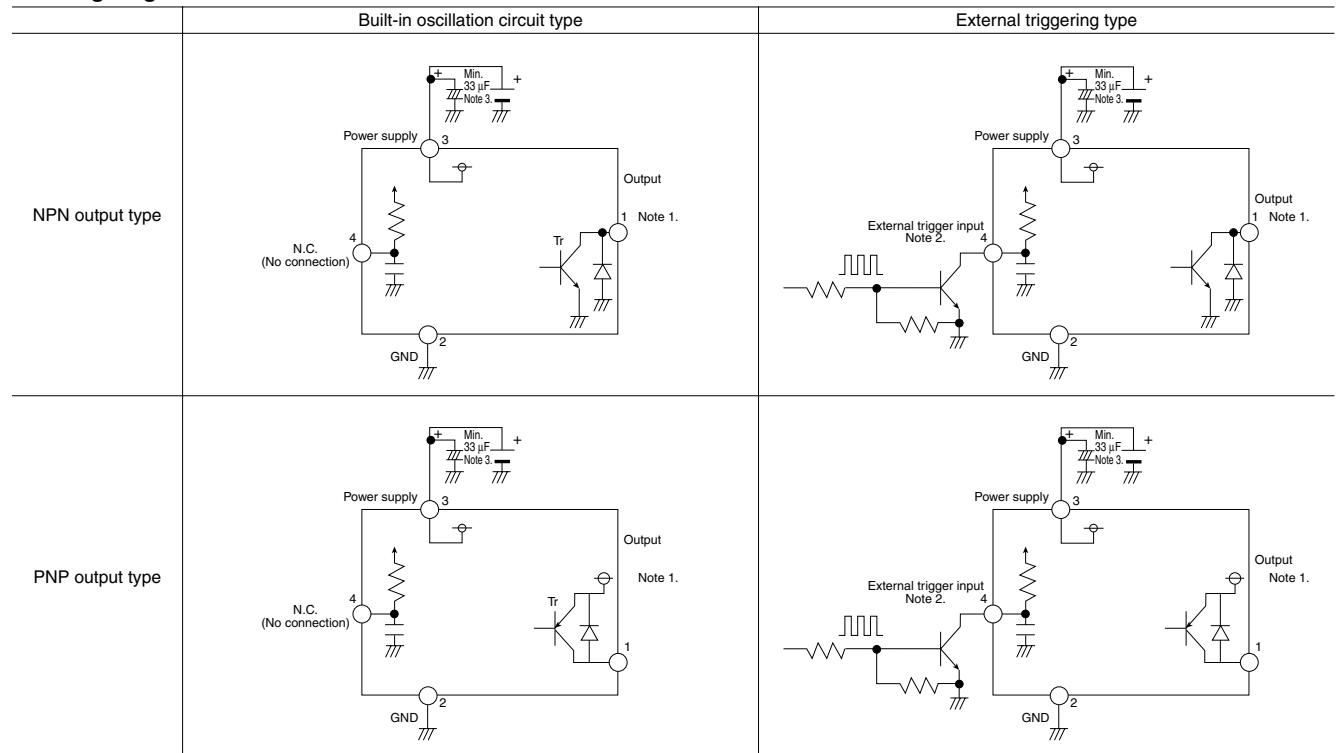

- Notes: 1. The output transistor has an open collector structure.
- Detection status: Output transistor ON (connected to GND)
  - Non-detection status: Output transistor OFF (open state)
2. The status of the external trigger input is as follows:
- Open at the high level
  - GND (less than 0.8V) at the low level
- Under no circumstances must a high-level voltage be applied.
3. To maintain the power supply superimposed noise performance, be certain to connect a capacitor (33µF or more) to the sensor power supply input terminal in order to stabilize the power supply voltage.

# MA Motion Sensor (AMA1, AMB1, 2, 3)

## REFERENCE DATA

### Operating region characteristics

• How to interpret the graph

Example: Operating area of the Short Type with rated detection distance of 8 cm 3.150 inch.

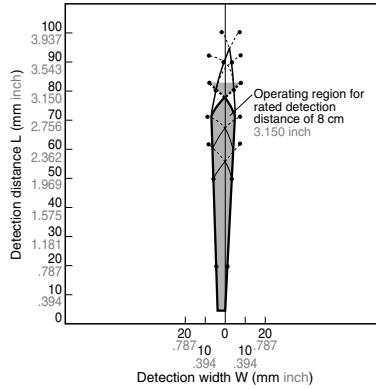

Operating area within the dotted lines

Objects that enter the entire area are detected.

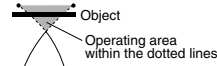

Note: If only part of the object is in the detection area, it is not detected.

Operating area within the solid lines

Objects that even partially enter the area are detected.

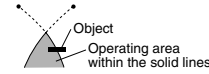

1.-(1) Thin short type (AMA14□□□□□) Short type (AMB14□□□□□)

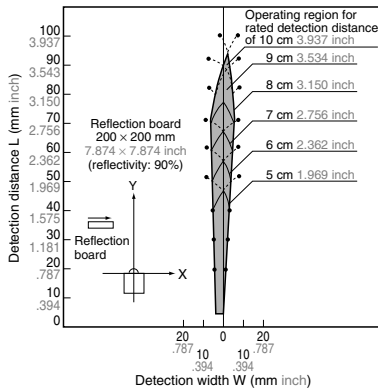

1.-(2) Middle type (AMB24□□□□□)

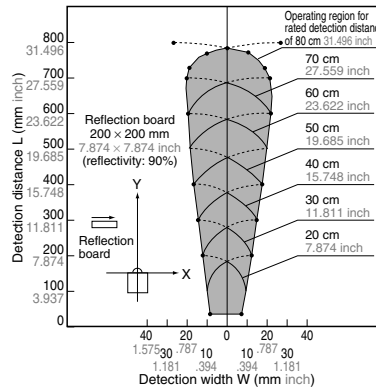

1.-(3) Long type (AMB34□□□□□)

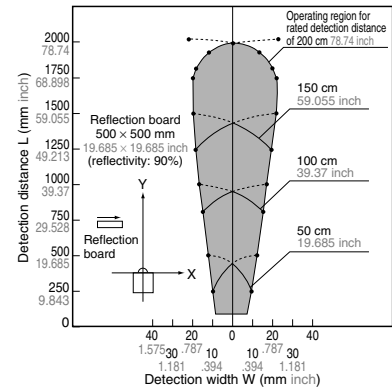

## DIMENSIONS (mm inch)

The CAD data of the products with a **CAD Data** mark can be downloaded from: <http://panasonic-electric-works.net/ac>

(Common to the Built-in oscillation circuit type and External triggering type)

### 1. Thin short type (V type)

**CAD Data**

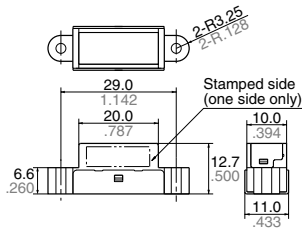

\*Rear side connector protrusion: Max. 0.4mm

### 2. Short type (H type)

**CAD Data**

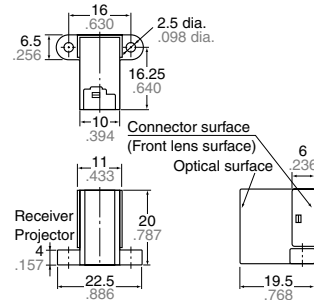

### 3. Middle type (H type)

**CAD Data**

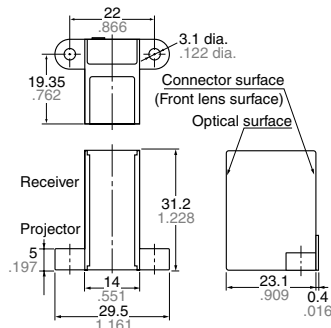



# MA Motion Sensor (AMA1, AMB1, 2, 3)

## 4. Long type (H type)

### CAD Data

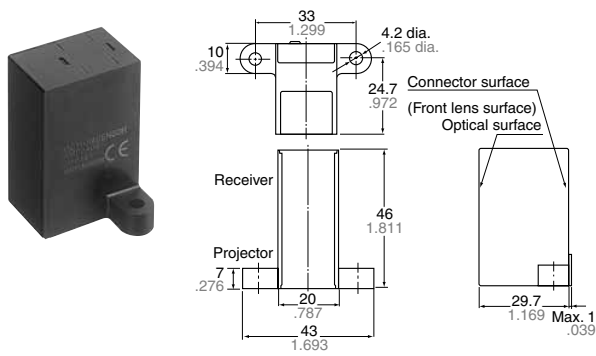

## 5. Long type (V type)

### CAD Data

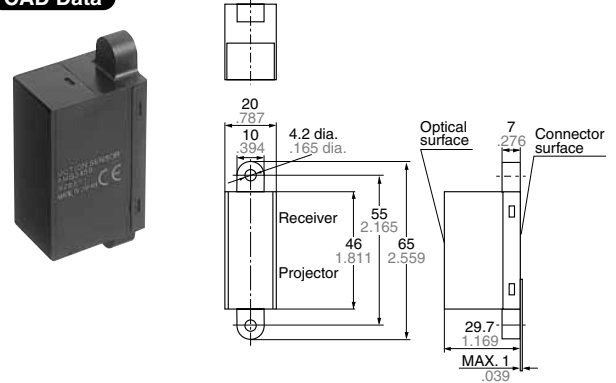

## WIRING DIAGRAM (Connector surface view)

### 1. Thin short type (V type)

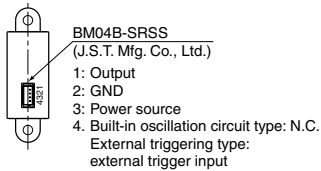

### 2. Short type (H type)

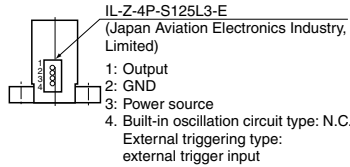

### 3. Middle type (H type)

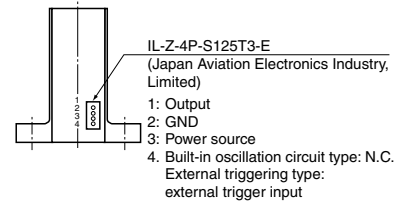

## 4. Long type (H type)

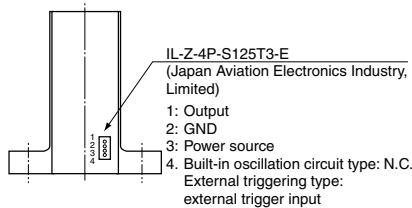

## 5. Long type (V type)

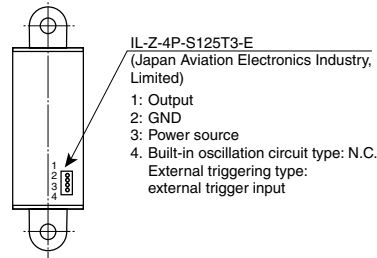

## OPTIONS (mm inch)

### 1. Connector with cable (for Short, Middle and Long type)

AMV9001

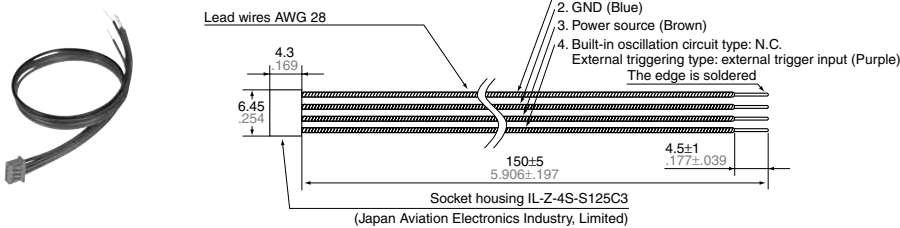

Note: Mistaken cable assembly can cause damage to the internal circuits, so please check the power cord before switching ON. (Particular care must be taken as to avoid reverse connection of the power.)

### 2. Connector with cable (for Thin short type)

AMV9002

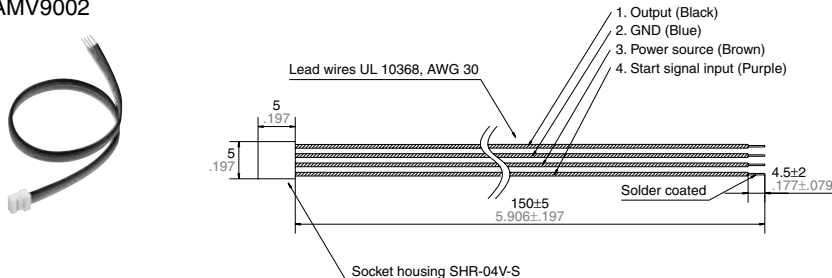

# MA Motion Sensor (AMA1, AMB1, 2, 3)

## NOTES

### 1. Environment

- 1) Avoid using the sensor in environments containing excessive amounts of steam, dust, corrosive gas, or where organic solvents are present.
- 2) When the sensor is used in noisy environments, connect a capacitor (minimum 33  $\mu$ F) across its power input terminals.

### 2. Wiring

- 1) Check all wiring before applying power. Incorrect wiring may damage the internal circuit (in particular, check that the connection to the power supply is not reversed.)
- 2) Avoid excessive removing and replacing of the connector.

### 3. Detector surface (Optical surface)

- 1) Keep the detector surface clean. Excessive dust or dirt on the detector surface will deteriorate the sensing performance.
- 2) Do not allow condensation or freezing to occur on the surface of the sensor. If condensation or freezing does occur at low temperatures, the sensor may not detect objects correctly.

3) This product is designed to detect the existence of human body. The sensor will not detect objects consisting of a low reflective material (e.g., an object coated with black rubber, etc.) or of a highly reflective material (e.g., mirror, glass, coated paper, etc.)

4) The front surface of the lens and case are made of polycarbonate resin and can withstand water, alcohol, oils, salts and weak acids. Other fluids such as alkalines, aromatic hydrocarbons and halogenated hydrocarbons may melt or swell the lens and case, please do not have such fluids touch the lens and case.

5) If you use the sensor with a cover or filter connected to the front of the sensor, the sensor may detect the cover itself, the detection distance can change, and unstable operation can result.

6) When multiple sensors are to be used side by side, please verify that there will be no mutual interference by installing them with the proper spacing, depending on the type as shown below.

Model number	Sensor spacing
AMB1 series	5 cm 1.969 inch
AMA1 series	8 cm 3.150 inch
AMB2 series	10 cm 3.937 inch
AMB3 series	20 cm 7.874 inch

7) To protect the inner circuit, wiring should be max. 3 m 9.843 ft..

### 4. Recommended installation procedure

Install the sensor so that it is orientated correctly in relation to the pass directions of the target objects as shown in the figure below.

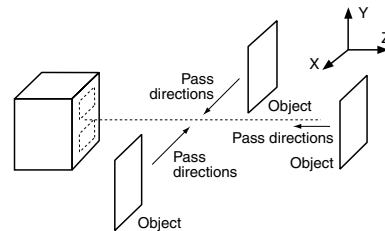

\* → stands for pass direction of the target object.

For the general precautions, refer to "NOTES FOR USING MOTION SENSOR (Common)" on next page.

# NOTES FOR USING MOTION SENSOR (Common)

## SAFETY PRECAUTIONS

Head the following precautions to prevent injury or accidents.

- Do not use these sensors under any circumstances in which the range of their ratings, environment conditions or other specifications are exceeded. Using the sensors in any way which causes their specifications to be exceeded may generate abnormally high levels of heat, emit smoke, etc., resulting in damage to the circuitry and possibly causing an accident.

- Before connecting a connector, check the pin layout by referring to the connector wiring diagram, specifications diagram, etc., and make sure that the connector is connected properly. Take note that mistakes made in connection may cause unforeseen problems in operation, generate abnormally high levels of heat, emit smoke, etc., resulting in damage to the circuitry.

- Do not use any motion sensor which has been disassembled or remodeled.
- Protection circuit recommended

The possible failure mode is either open or short of the output transistor. An excess heat is the cause for short mode failure. For any important and serious application in terms of safety, add protection circuit or any other protection method.

## NOTES FOR MOTION SENSOR

### 1. Ambient operating conditions

- Temperature: Refer to the absolute maximum ratings for the temperature of each individual sensor.
- Humidity: 15% to 85% RH (No freezing nor condensation at low temperature)
- Atmospheric pressure: 86 to 106 kPa
- Because the humidity range differs depending on the ambient temperature, the humidity range indicated below should be used. Continuous operation of the switch is possible within this range, but continuous use near the limit of the range should be avoided. This humidity range does not guarantee permanent performance.

<MP Motion Sensor>

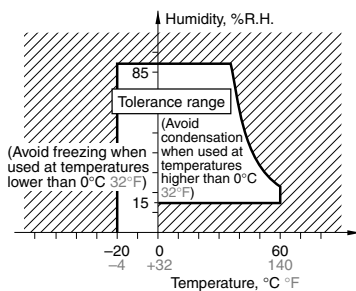

<MA Motion Sensor>

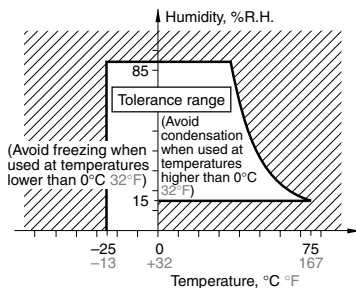

In general, degradation of electronic devices accelerates when they are operated under conditions of high temperature or high humidity. Before use, confirm the reliability of the sensors under the expected operating conditions.

- The sensors do not have a water-proof or dust-proof construction. Depending on the ambient operating conditions, some means of providing protection from water and dust and preventing the formation of ice and condensation must be provided prior to using the sensors. If a sensor is used with a cover installed, the initial detection performance specifications may not be able to be met. Confirm the operation under the actual operating conditions.

- Take care to avoid exposing the sensors to heat, vibration or impact since malfunctioning may result.

### 2. Concerning external surge voltages

Since the internal circuitry may be destroyed if an external surge voltages is supplied, provide an element which will absorb the surges. The levels of the voltage surges which the sensor can withstand is given below.

MA motion sensors: 500 V ( $\pm 1.2 \times 50\mu\text{s}$  unipolar full-wave voltage)

MP motion sensors: Within the supply voltage given in the absolute maximum ratings.

### 3. Concerning power supply-superimposed noise

- Use a regulated power supply as the power supply. Otherwise, power supply-superimposed noise may cause the sensors to malfunction. The levels of noise which the sensor can withstand is given below.

MA motion sensors:  $\pm 200$  V (50ns, 1 $\mu\text{s}$  wide square waves)

MP motion sensors:  $\pm 20$  V (50ns, 1 $\mu\text{s}$  wide square waves)

- To maintain the power supply noise performance, be certain to connect a capacitor (33 $\mu\text{F}$  or more) to the sensor power supply input terminal in order to stabilize the power supply voltage.

### 4. Drop damage

If the sensor is dropped, damage can occur resulting in incorrect operation. If dropped, be sure to do a visual check of the exterior for noticeable damage and check the operation characteristics for faulty operation.

### 5. Concerning the circuit sides

Since the circuit sides given in this catalog are not protected in terms of circuit design, check out the performance and reliability of the circuits prior to using the sensors.