

SCAN92LV090

9 Channel Bus LVDS Transceiver w/ Boundary SCAN

General Description

The SCAN92LV090A is one in a series of Bus LVDS transceivers designed specifically for the high speed, low power proprietary backplane or cable interfaces. The device operates from a single 3.3V power supply and includes nine differential line drivers and nine receivers. To minimize bus loading, the driver outputs and receiver inputs are internally connected. The separate I/O of the logic side allows for loop back support. The device also features a flow through pin out which allows easy PCB routing for short stubs between its pins and the connector.

The driver translates 3V TTL levels (single-ended) to differential Bus LVDS (BLVDS) output levels. This allows for high speed operation, while consuming minimal power with reduced EMI. In addition, the differential signaling provides common mode noise rejection of $\pm 1V$.

The receiver threshold is less than ± 100 mV over a $\pm 1V$ common mode range and translates the differential Bus LVDS to standard (TTL/CMOS) levels.

This device is compliant with IEEE 1149.1 Standard Test Access Port and Boundary Scan Architecture with the incorporation of the defined boundary-scan test logic and test access

port consisting of Test Data Input (TDI), Test Data Out (TDO), Test Mode Select (TMS), Test Clock (TCK), and the optional Test Reset (TRST).

Features

- IEEE 1149.1 (JTAG) Compliant
- Bus LVDS Signaling
- Low power CMOS design
- High Signaling Rate Capability (above 100 Mbps)
- 0.1V to 2.3V Common Mode Range for $V_{ID} = 200mV$
- ± 100 mV Receiver Sensitivity
- Supports open and terminated failsafe on port pins
- 3.3V operation
- Glitch free power up/down (Driver & Receiver disabled)
- Light Bus Loading (5 pF typical) per Bus LVDS load
- Designed for Double Termination Applications
- Balanced Output Impedance
- Product offered in 64 pin LQFP package and BGA package
- High impedance Bus pins on power off ($V_{CC} = 0V$)

Simplified Functional Diagram

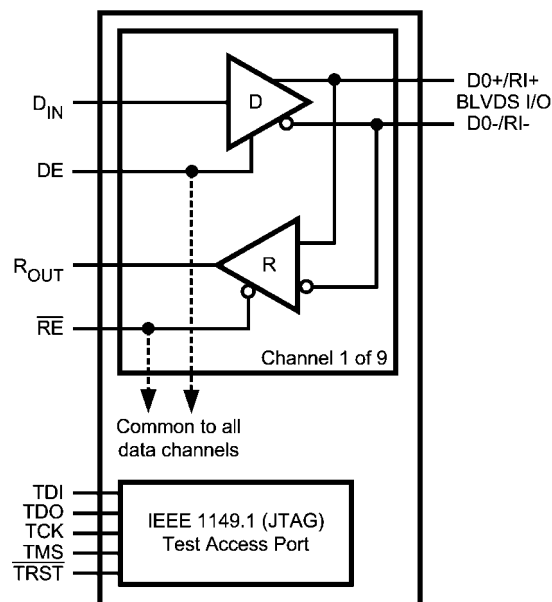

10124201

Connection Diagrams

TRI-STATE® is a registered trademark of National Semiconductor Corporation.

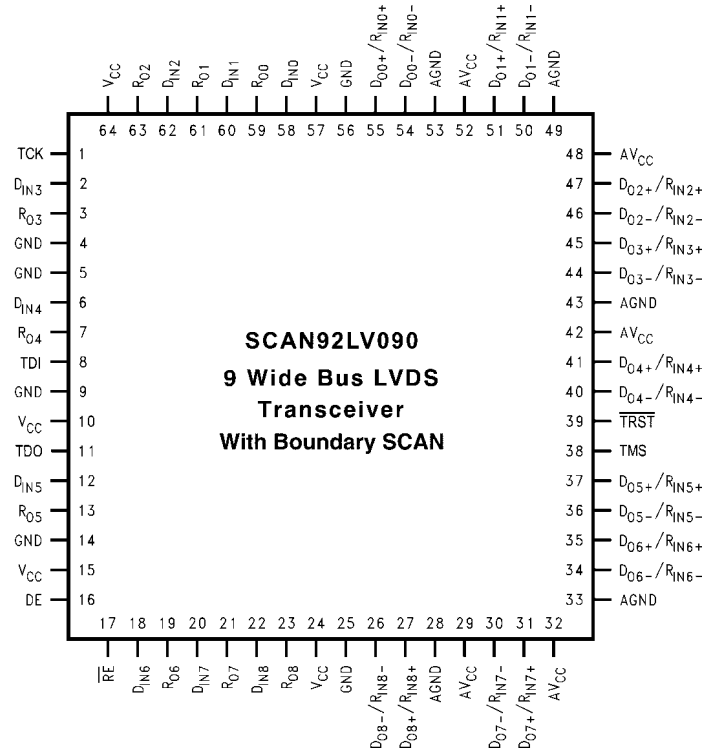

10124202

Top View
Order Number SCAN92LV090VEH
See NS Package Number VEH064DB

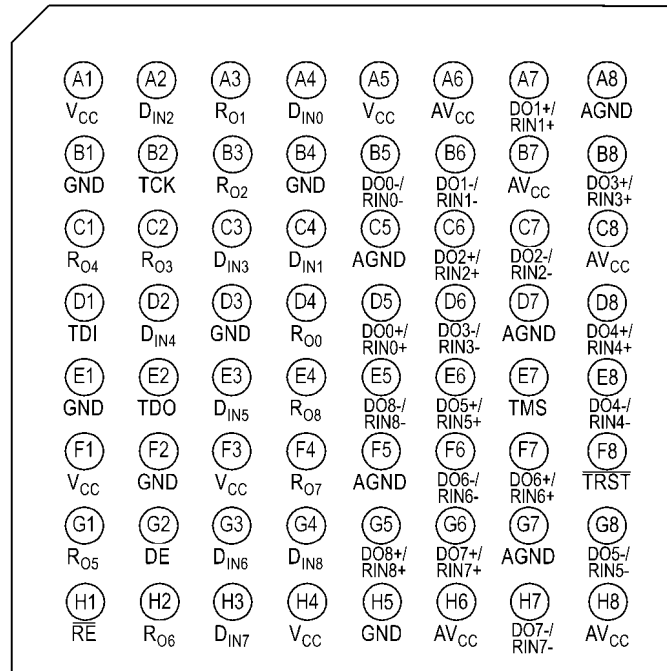

10124216

Top View
Order Number SCAN92LV090SLC
See NS Package Number SLC64A

Pinout Description

Pin Name	TQFP Pin #	BGA Pin #	Input/Output	Descriptions
DO+/RI+	27, 31, 35, 37, 41, 45, 47, 51, 55	A7, B8, C6, D5, D8, E6, F7, G5, G6	I/O	True Bus LVDS Driver Outputs and Receiver Inputs.
DO-/RI-	26, 30, 34, 36, 40, 44, 46, 50, 54	B5, B6, C7, D6, E5, E8, F6, G8, H7	I/O	Complimentary Bus LVDS Driver Outputs and Receiver Inputs.
D _{IN}	2, 6, 12, 18, 20, 22, 58, 60, 62	A2, A4, C3, C4, D2, E3, G3, G4, H3	I	TTL Driver Input.
RO	3, 7, 13, 19, 21, 23, 59, 61, 63	A3, B3, C1, C2, D4, E4, F4, G1, H2	O	TTL Receiver Output.
$\overline{\text{RE}}$	17	H1	I	Receiver Enable TTL Input (Active Low).
DE	16	G2	I	Driver Enable TTL Input (Active High).
GND	4, 5, 9, 14, 25, 56	B1, B4, D3, E1, F2, H5	Power	Ground for digital circuitry (must connect to GND on PC board). These pins connected internally.
V _{CC}	10, 15, 24, 57, 64	A1, A5, F1, F3, H4	Power	V _{CC} for digital circuitry (must connect to V _{CC} on PC board). These pins connected internally.
AGND	28, 33, 43, 49, 53	A8, C5, D7, F5, G7	Power	Ground for analog circuitry (must connect to GND on PC board). These pins connected internally.
AV _{CC}	29, 32, 42, 48, 52	A6, B7, C8, H6, H8	Power	Analog V _{CC} (must connect to V _{CC} on PC board). These pins connected internally.
$\overline{\text{TRST}}$	39	F8	I	Test Reset Input to support IEEE 1149.1 (Active Low)
TMS	38	E7	I	Test Mode Select Input to support IEEE 1149.1
TCK	1	B2	I	Test Clock Input to support IEEE 1149.1
TDI	8	D1	I	Test Data Input to support IEEE 1149.1
TDO	11	E2	O	Test Data Output to support IEEE 1149.1

Absolute Maximum Ratings (Notes 2, 1)

If Military/Aerospace specified devices are required, please contact the National Semiconductor Sales Office/ Distributors for availability and specifications.

Supply Voltage (V_{CC})	4.0V
Enable Input Voltage (DE, \overline{RE})	-0.3V to ($V_{CC} + 0.3V$)
Driver Input Voltage (D_{IN})	-0.3V to ($V_{CC} + 0.3V$)
Receiver Output Voltage (R_{OUT})	-0.3V to ($V_{CC} + 0.3V$)
Bus Pin Voltage ($DO/RI\pm$)	-0.3V to +3.9V
ESD (HBM 1.5 k Ω , 100 pF)	>4.5 kV
Driver Short Circuit Duration	momentary
Receiver Short Circuit Duration	momentary
Maximum Package Power Dissipation at 25°C	
LQFP	1.74 W
Derate LQFP Package	13.9 mW/°C
θ_{ja}	71.7°C/W

θ_{jc}	10.9°C/W
Junction Temperature	+150°C
Storage Temperature Range	-65°C to +150°C
Lead Temperature (Soldering, 4 sec.)	260°C

Recommended Operating Conditions

	Min	Max	Units
Supply Voltage (V_{CC})	3.0	3.6	V
Receiver Input Voltage	0.0	2.4	V
Operating Free Air Temperature	-40	+85	°C
Maximum Input Edge Rate (Note 6)(20% to 80%)			$\Delta t/\Delta V$
Data		1.0	ns/V
Control		3.0	ns/V

DC Electrical Characteristics

Over recommended operating supply voltage and temperature ranges unless otherwise specified (Notes 2, 3)

Symbol	Parameter	Conditions	Pin	Min	Typ	Max	Units		
V_{OD}	Output Differential Voltage	$R_L = 27\Omega$, Figure 1	DO+/RI+, DO-/RI-	240	300	460	mV		
ΔV_{OD}	V_{OD} Magnitude Change					27	mV		
V_{OS}	Offset Voltage			1.1	1.3	1.5	V		
ΔV_{OS}	Offset Magnitude Change				5	10	mV		
V_{OH}	Driver Output High Voltage	$R_L = 27\Omega$			1.4	1.65	V		
V_{OL}	Driver Output Low Voltage	$R_L = 27\Omega$		0.95	1.1		V		
I_{OSD}	Output Short Circuit Current (Note 10)	$V_{OD} = 0V$, DE = V_{CC} , Driver outputs shorted together			36	65	mA		
V_{OH}	Voltage Output High (Note 11)	$V_{ID} = +300$ mV	R_{OUT}	$V_{CC}-0.2$			V		
		Inputs Open					$V_{CC}-0.2$		V
		Inputs Terminated, $R_L = 27\Omega$					$V_{CC}-0.2$		V
V_{OL}	Voltage Output Low	$I_{OL} = 2.0$ mA, $V_{ID} = -300$ mV			0.05	0.075	V		
I_{OD}	Receiver Output Dynamic Current (Note 10)	$V_{ID} = 300$ mV, $V_{OUT} = V_{CC}-1.0V$		-110	75		mA		
		$V_{ID} = -300$ mV, $V_{OUT} = 1.0V$			75	110	mA		
V_{TH}	Input Threshold High	DE = 0V, $V_{CM} = 1.5V$	DO+/RI+, DO-/RI-			+100	mV		
V_{TL}	Input Threshold Low			-100			mV		
V_{CMR}	Receiver Common Mode Range			$ V_{ID} /2$		2.4 - $V_{ID} /2$	V		
I_{IN}	Input Current	DE = 0V, $\overline{RE} = 2.4V$, $V_{IN} = +2.4V$ or 0V		-25	± 1	+25	μA		
		$V_{CC} = 0V$, $V_{IN} = +2.4V$ or 0V		-20	± 1	+20	μA		
V_{IH}	Minimum Input High Voltage		D_{IN} , DE, \overline{RE} , TCK,	2.0		V_{CC}	V		
V_{IL}	Maximum Input Low Voltage		\overline{TRST} , TMS, TDI	GND		0.8	V		
I_{IH}	Input High Current	$V_{IN} = V_{CC}$ or 2.4V	D_{IN} , DE, \overline{RE}	-20	± 10	+20	μA		
I_{IL}	Input Low Current	$V_{IN} = GND$ or 0.4V		-20	± 10	+20	μA		
V_{CL}	Input Diode Clamp Voltage	$I_{CLAMP} = -18$ mA		-1.5	-0.8		V		

Symbol	Parameter	Conditions	Pin	Min	Typ	Max	Units
I_{IH}	Input High Current	$V_{IN} = V_{CC}$	TDI, TMS, TCK, \overline{TRST}	-20		+20	μA
I_{ILR}	Input Low Current	$V_{IN} = GND, V_{CC} = 3.6V$	TDI, TMS, \overline{TRST}	-25		-115	μA
I_{IL}	Input Low Current	$V_{IN} = GND$	TCK	-20		+20	μA
I_{CCD}	Power Supply Current Drivers Enabled, Receivers Disabled	No Load, $DE = \overline{RE} = V_{CC}$, $DIN = V_{CC}$ or GND	V_{CC}		50	80	mA
I_{CCR}	Power Supply Current Drivers Disabled, Receivers Enabled	$DE = \overline{RE} = 0V, V_{ID} = \pm 300mV$			50	80	mA
I_{CCZ}	Power Supply Current, Drivers and Receivers TRI-STATE®	$DE = 0V; \overline{RE} = V_{CC}$, $DIN = V_{CC}$ or GND			50	80	mA
I_{CC}	Power Supply Current, Drivers and Receivers Enabled	$DE = V_{CC}; \overline{RE} = 0V$, $DIN = V_{CC}$ or GND, $R_L = 27\Omega$			160	210	mA
I_{CCS}	Power Supply Current (SCAN Test Mode), Drivers and Receivers Enabled	$DE = V_{CC}; \overline{RE} = 0V$, $DIN = V_{CC}$ or GND, $R_L = 27\Omega$, TAP in any state other than Test-Logic-Reset			180	230	mA
I_{OFF}	Power Off Leakage Current	$V_{CC} = 0V$ or OPEN, $D_{IN}, DE, \overline{RE} = 0V$ or OPEN, $V_{APPLIED} = 3.6V$ (Port Pins)	DO+/RI+, DO-/RI-	-20		+20	μA
C_{OUTPUT}	Capacitance @ Bus Pins		DO+/RI+, DO-/RI-		5		pF
C_{OUTPUT}	Capacitance @ R_{OUT}		R_{OUT}		7		pF

AC Electrical Characteristics

Over recommended operating supply voltage and temperature ranges unless otherwise specified (Note 6)

Symbol	Parameter	Conditions	Min	Typ	Max	Units	
DIFFERENTIAL DRIVER TIMING REQUIREMENTS							
t_{PHLD}	Differential Prop. Delay High to Low (Note 8)	$R_L = 27\Omega$, <i>Figure 2, Figure 3</i> $C_L = 10\text{ pF}$	1.0	1.8	2.6	ns	
t_{PLHD}	Differential Prop. Delay Low to High (Note 8)		1.0	1.8	2.6	ns	
t_{SKD1}	Differential Skew $ t_{PHLD} - t_{PLHD} $ (Note 9)				120	ps	
t_{SKD2}	Chip to Chip Skew (Note 12)				1.6	ns	
t_{SKD3}	Channel to Channel Skew (Note 13)			0.25	0.55	ns	
t_{TLH}	Transition Time Low to High				0.5	1.2	ns
t_{THL}	Transition Time High to Low				0.5	1.2	ns
t_{PHZ}	Disable Time High to Z	$R_L = 27\Omega$, <i>Figure 4, Figure 5</i> $C_L = 10\text{ pF}$		3	8	ns	
t_{PLZ}	Disable Time Low to Z			3	8	ns	
t_{PZH}	Enable Time Z to High			3	8	ns	
t_{PZL}	Enable Time Z to Low			3	8	ns	
DIFFERENTIAL RECEIVER TIMING REQUIREMENTS							

Symbol	Parameter	Conditions	Min	Typ	Max	Units	
t_{PHLD}	Differential Prop. Delay High to Low (Note 8)	<i>Figure 6, Figure 7</i> $C_L = 35 \text{ pF}$	2.0	2.4	3.9	ns	
t_{PLHD}	Differential Prop Delay Low to High (Note 8)		2.0	2.4	3.9	ns	
t_{SDK1}	Differential Skew $ t_{PHLD} - t_{PLHD} $ (Note 9)			210		ps	
t_{SDK2}	Chip to Chip Skew (Note 12)				1.9	ns	
t_{SDK3}	Channel to Channel skew (Note 13)			0.35	0.7	ns	
t_{TLH}	Transition Time Low to High				1.5	2.5	ns
t_{THL}	Transition Time High to Low				1.5	2.5	ns
t_{PHZ}	Disable Time High to Z	$R_L = 500\Omega$, <i>Figure 8, Figure 9</i> $C_L = 35 \text{ pF}$		4.5	10	ns	
t_{PLZ}	Disable Time Low to Z			3.5	8	ns	
t_{PZH}	Enable Time Z to High			3.5	8	ns	
t_{PZL}	Enable Time Z to Low			3.5	8	ns	

SCAN CIRCUITRY TIMING REQUIREMENTS

f_{MAX}	Maximum TCK Clock Frequency	$R_L = 500\Omega$, $C_L = 35 \text{ pF}$	25.0	75.0		MHz
t_S	TDI to TCK, H or L		1.5			ns
t_H	TDI to TCK, H or L		1.5			ns
t_S	TMS to TCK, H or L		2.5			ns
t_H	TMS to TCK, H or L		1.5			ns
t_W	TCK Pulse Width, H or L		10.0			ns
t_W	$\overline{\text{TRST}}$ Pulse Width, L		2.5			ns
t_{REC}	Recovery Time, $\overline{\text{TRST}}$ to TCK		2.0			ns

Note 1: "Absolute Maximum Ratings" are those values beyond which the safety of the device cannot be guaranteed. They are not meant to imply that the devices should be operated at these limits. The table of "Electrical Characteristics" provides conditions for actual device operation.

Note 2: All currents into device pins are positive; all currents out of device pins are negative. All voltages are referenced to ground unless otherwise specified except V_{OD} , ΔV_{OD} and V_{ID} .

Note 3: All typicals are given for $V_{CC} = +3.3V$ and $T_A = +25^\circ C$, unless otherwise stated.

Note 4: ESD Rating: HBM (1.5 k Ω , 100 pF) > 4.5 kV EIAJ (0 Ω , 200 pF) > 300V.

Note 5: C_L includes probe and fixture capacitance.

Note 6: Generator waveforms for all tests unless otherwise specified: $f = 25 \text{ MHz}$, $Z_O = 50\Omega$, t_r , $t_f = < 1.0 \text{ ns}$ (0%–100%). To ensure fastest propagation delay and minimum skew, data input edge rates should be equal to or faster than 1ns/V; control signals equal to or faster than 3ns/V. In general, the faster the input edge rate, the better the AC performance.

Note 7: The DS92LV090A functions within datasheet specification when a resistive load is applied to the driver outputs.

Note 8: Propagation delays are guaranteed by design and characterization.

Note 9: $t_{SKD1} |t_{PHLD} - t_{PLHD}|$ is the worse case skew between any channel and any device over recommended operation conditions.

Note 10: Only one output at a time should be shorted, do not exceed maximum package power dissipation capacity.

Note 11: V_{OH} failsafe terminated test performed with 27 Ω connected between RI+ and RI- inputs. No external voltage is applied.

Note 12: Chip to Chip skew is the difference in differential propagation delay between any channels of any devices, either edge.

Note 13: Channel to Channel skew is the difference in driver output or receiver output propagation delay between any channels within a device, common edge.

Applications Information

General application guidelines and hints may be found in the following application notes: AN-808, AN-1108, AN-977, AN-971, and AN-903.

There are a few common practices which should be implied when designing PCB for Bus LVDS signaling. Recommended practices are:

- Use at least 4 PCB board layer (Bus LVDS signals, ground, power and TTL signals).
 - Keep drivers and receivers as close to the (Bus LVDS port side) connector as possible.
 - Bypass each Bus LVDS device and also use distributed bulk capacitance between power planes. Surface mount capacitors placed close to power and ground pins work best. Two or three high frequency, multi-layer ceramic (MLC) surface mount (0.1 μ F, 0.01 μ F, 0.001 μ F) in parallel should be used between each V_{CC} and ground. The capacitors should be as close as possible to the V_{CC} pin. Multiple vias should be used to connect V_{CC} and Ground planes to the pads of the by-pass capacitors. In addition, randomly distributed by-pass capacitors should be used.
 - Use the termination resistor which best matches the differential impedance of your transmission line.
 - Leave unused Bus LVDS receiver inputs open (floating). Limit traces on unused inputs to <0.5 inches.
 - Isolate TTL signals from Bus LVDS signals
- MEDIA (CONNECTOR or BACKPLANE) SELECTION:
- Use controlled impedance media. The backplane and connectors should have a matched differential impedance.

TABLE 1. Functional Table

MODE SELECTED	DE	\overline{RE}
DRIVER MODE	H	H
RECEIVER MODE	L	L
TRI-STATE MODE	L	H
LOOP BACK MODE	H	L

TABLE 2. Transmitter Mode

INPUTS		OUTPUTS	
DE	D_{IN}	DO+	DO-
H	L	L	H
H	H	H	L
H	$0.8V < D_{IN} < 2.0V$	X	X
L	X	Z	Z

TABLE 3. Receiver Mode

INPUTS		OUTPUT
RE	(RI+) - (RI-)	T
L	L (< -100 mV)	L
L	H (> +100 mV)	H
L	$-100 \text{ mV} < V_{ID} < +100 \text{ mV}$	X
H	X	Z

X = High or Low logic state
 L = Low state
 Z = High impedance state
 H = High state

Test Circuits and Timing Waveforms

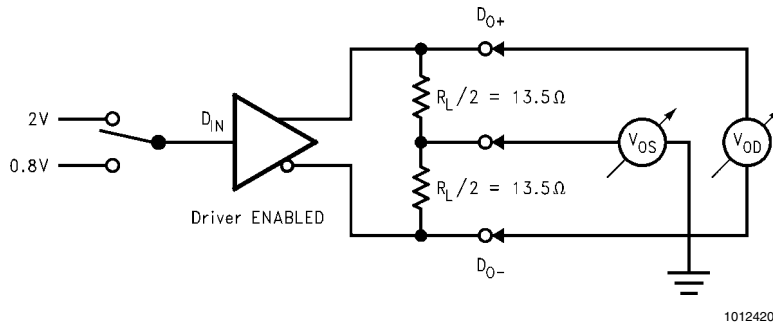

FIGURE 1. Differential Driver DC Test Circuit

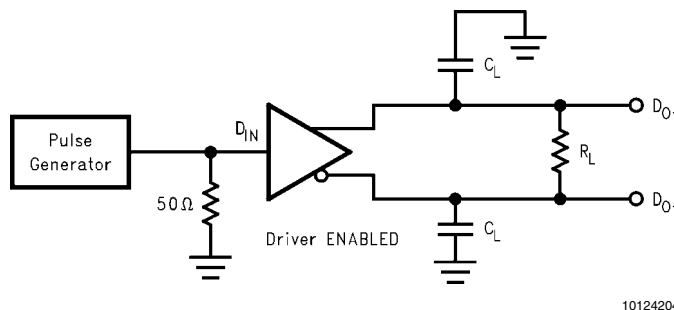
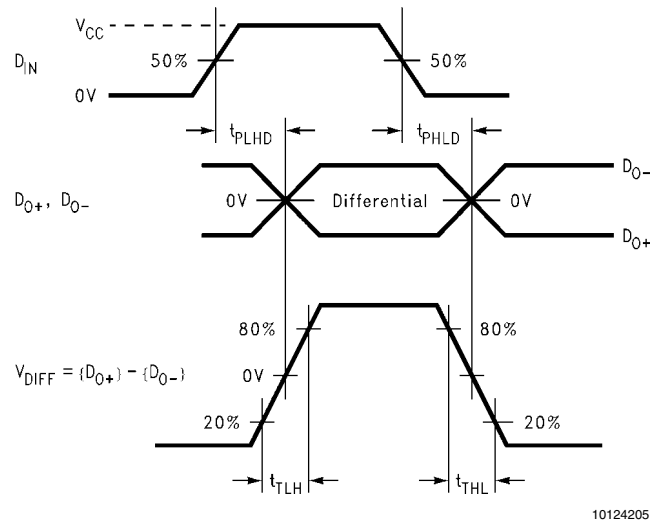
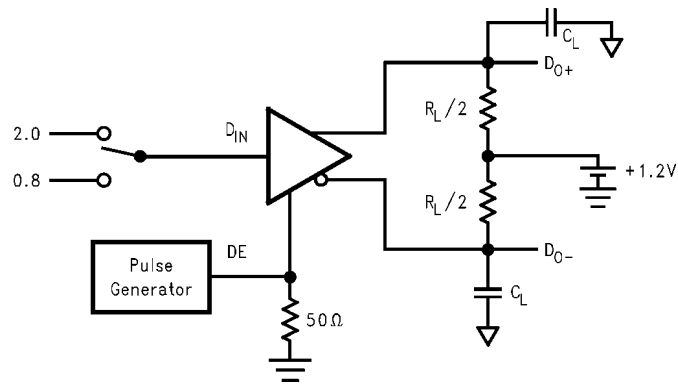

FIGURE 2. Differential Driver Propagation Delay and Transition Time Test Circuit



10124205

FIGURE 3. Differential Driver Propagation Delay and Transition Time Waveforms



10124206

FIGURE 4. Driver TRI-STATE Delay Test Circuit

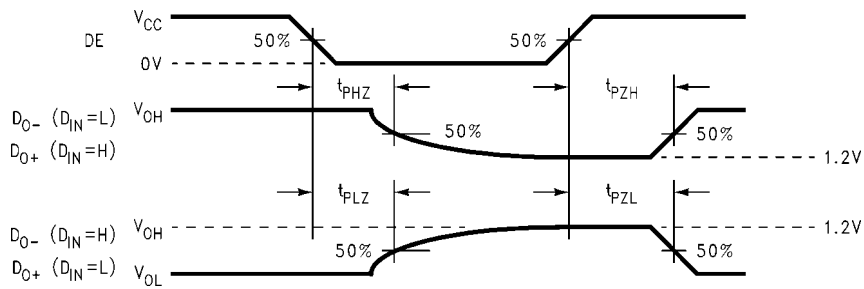

10124207

FIGURE 5. Driver TRI-STATE Delay Waveforms

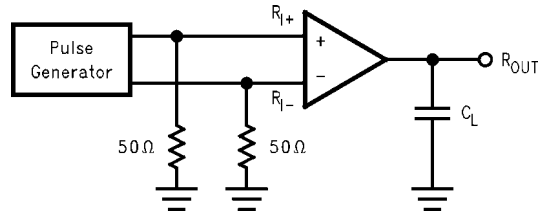

10124208

FIGURE 6. Receiver Propagation Delay and Transition Time Test Circuit

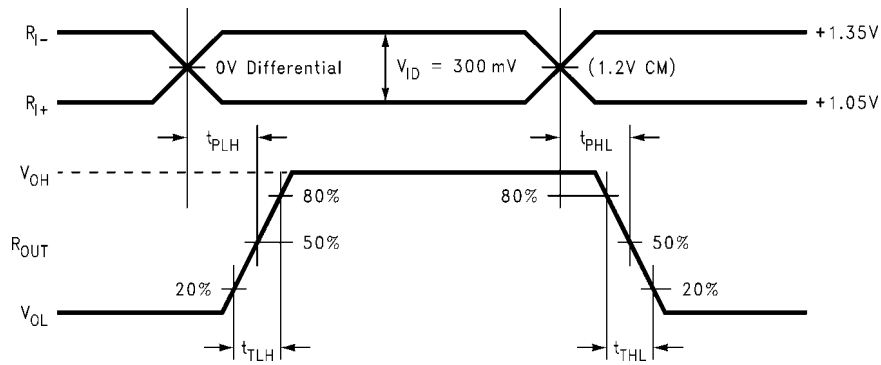

10124214

FIGURE 7. Receiver Propagation Delay and Transition Time Waveforms

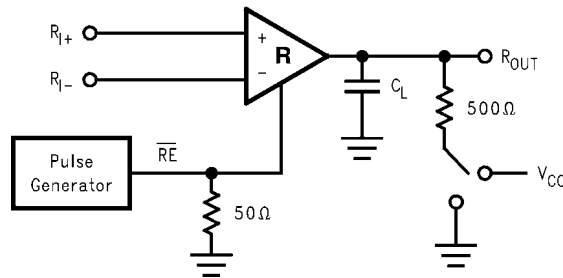

10124215

FIGURE 8. Receiver TRI-STATE Delay Test Circuit

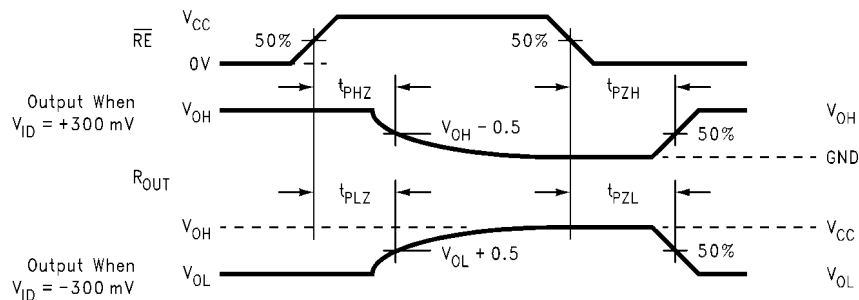

10124211

FIGURE 9. Receiver TRI-STATE Delay Waveforms

Typical Bus Application Configurations

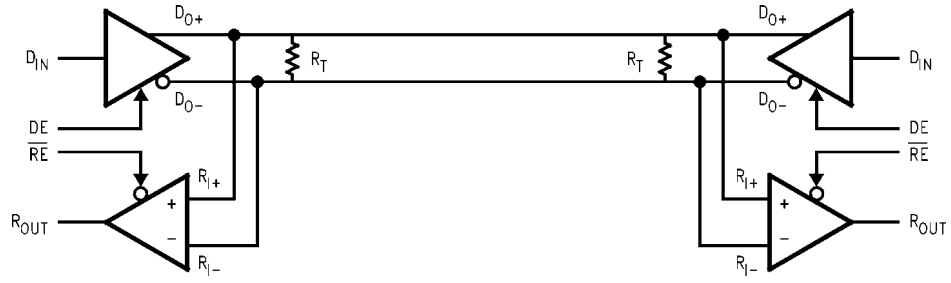

10124212

Bi-Directional Half-Duplex Point-to-Point Applications

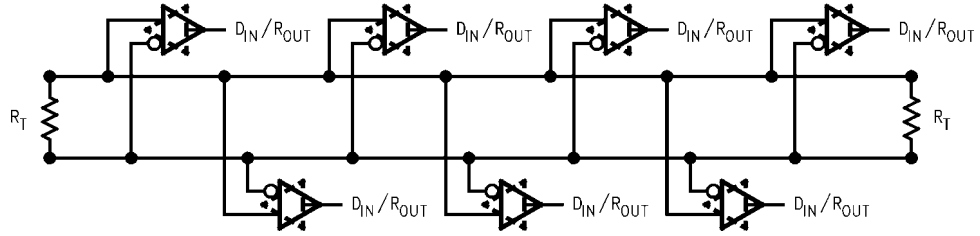

10124213

Multi-Point Bus Applications

Description of Boundary-Scan Circuitry

The SCAN92LV090 features two unique Scan test modes, each which requires a unique BSDL model depending on the level of test access and fault coverage goals. In the first mode (Mode0), only the TTL Inputs and Outputs of each transceiver are accessible via a 1149.1 compliant protocol. In the second mode (Mode1), both the TTL Inputs and Outputs and the differential LVDS I/Os are included in the Scan chain.

All test modes are handled by the ATPG software, and BSDL selection should be invisible to the user.

The BYPASS register is a single bit shift register stage identical to scan cell TYPE1. It captures a fixed logic low.

Bypass Register Scan Chain Definition Logic 0

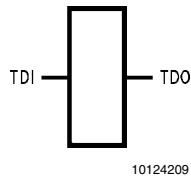

The INSTRUCTION register is an eight-bit register which captures the value 00111101.

Instruction Register Scan Chain Definition

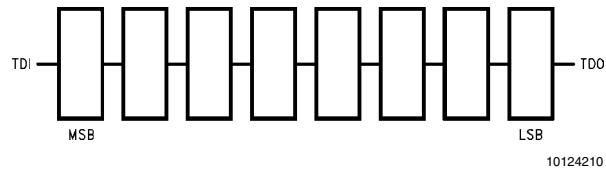

MSB → LSB (Mode0)

Instruction Code	Instruction
00000000	EXTEST
10000010	SAMPLE/PRELOAD
10000111	CLAMP
00000110	HIGHZ
All Others	BYPASS

MSB → LSB (Mode1)

Instruction Code	Instruction
10011001	EXTEST
10010010	SAMPLE/PRELOAD
10001111	CLAMP
00000110	HIGHZ
All Others	BYPASS

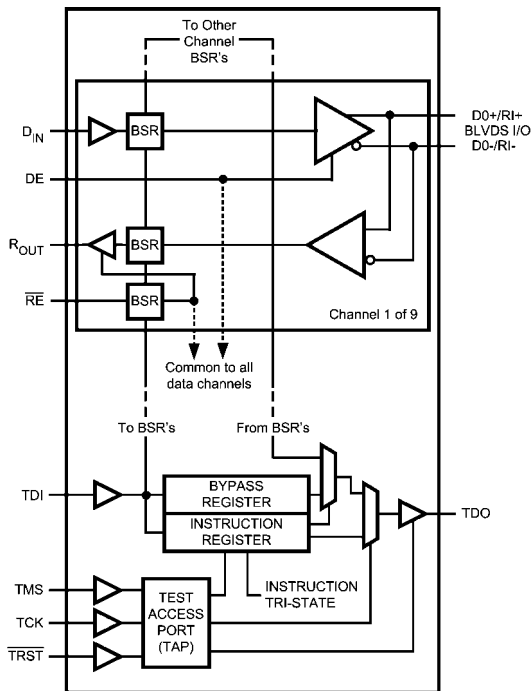

Mode 0 Boundary Scan Register Configuration (Refer to the BSDL for exact register order)

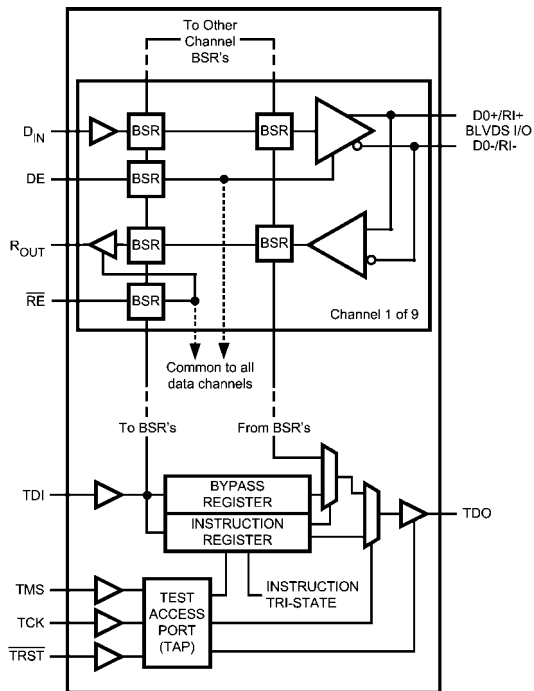

Mode 1 Boundary Scan Register Configuration (Refer to the BSDL for exact register order)

Notes

SCAN92LV090

Notes

THE CONTENTS OF THIS DOCUMENT ARE PROVIDED IN CONNECTION WITH NATIONAL SEMICONDUCTOR CORPORATION ("NATIONAL") PRODUCTS. NATIONAL MAKES NO REPRESENTATIONS OR WARRANTIES WITH RESPECT TO THE ACCURACY OR COMPLETENESS OF THE CONTENTS OF THIS PUBLICATION AND RESERVES THE RIGHT TO MAKE CHANGES TO SPECIFICATIONS AND PRODUCT DESCRIPTIONS AT ANY TIME WITHOUT NOTICE. NO LICENSE, WHETHER EXPRESS, IMPLIED, ARISING BY ESTOPPEL OR OTHERWISE, TO ANY INTELLECTUAL PROPERTY RIGHTS IS GRANTED BY THIS DOCUMENT.

TESTING AND OTHER QUALITY CONTROLS ARE USED TO THE EXTENT NATIONAL DEEMS NECESSARY TO SUPPORT NATIONAL'S PRODUCT WARRANTY. EXCEPT WHERE MANDATED BY GOVERNMENT REQUIREMENTS, TESTING OF ALL PARAMETERS OF EACH PRODUCT IS NOT NECESSARILY PERFORMED. NATIONAL ASSUMES NO LIABILITY FOR APPLICATIONS ASSISTANCE OR BUYER PRODUCT DESIGN. BUYERS ARE RESPONSIBLE FOR THEIR PRODUCTS AND APPLICATIONS USING NATIONAL COMPONENTS. PRIOR TO USING OR DISTRIBUTING ANY PRODUCTS THAT INCLUDE NATIONAL COMPONENTS, BUYERS SHOULD PROVIDE ADEQUATE DESIGN, TESTING AND OPERATING SAFEGUARDS.

EXCEPT AS PROVIDED IN NATIONAL'S TERMS AND CONDITIONS OF SALE FOR SUCH PRODUCTS, NATIONAL ASSUMES NO LIABILITY WHATSOEVER, AND NATIONAL DISCLAIMS ANY EXPRESS OR IMPLIED WARRANTY RELATING TO THE SALE AND/OR USE OF NATIONAL PRODUCTS INCLUDING LIABILITY OR WARRANTIES RELATING TO FITNESS FOR A PARTICULAR PURPOSE, MERCHANTABILITY, OR INFRINGEMENT OF ANY PATENT, COPYRIGHT OR OTHER INTELLECTUAL PROPERTY RIGHT.

LIFE SUPPORT POLICY

NATIONAL'S PRODUCTS ARE NOT AUTHORIZED FOR USE AS CRITICAL COMPONENTS IN LIFE SUPPORT DEVICES OR SYSTEMS WITHOUT THE EXPRESS PRIOR WRITTEN APPROVAL OF THE CHIEF EXECUTIVE OFFICER AND GENERAL COUNSEL OF NATIONAL SEMICONDUCTOR CORPORATION. As used herein:

Life support devices or systems are devices which (a) are intended for surgical implant into the body, or (b) support or sustain life and whose failure to perform when properly used in accordance with instructions for use provided in the labeling can be reasonably expected to result in a significant injury to the user. A critical component is any component in a life support device or system whose failure to perform can be reasonably expected to cause the failure of the life support device or system or to affect its safety or effectiveness.

National Semiconductor and the National Semiconductor logo are registered trademarks of National Semiconductor Corporation. All other brand or product names may be trademarks or registered trademarks of their respective holders.

Copyright© 2007 National Semiconductor Corporation

For the most current product information visit us at www.national.com



**National Semiconductor
Americas Customer
Support Center**
Email:
new.feedback@nsc.com
Tel: 1-800-272-9959

**National Semiconductor Europe
Customer Support Center**
Fax: +49 (0) 180-530-85-86
Email: europe.support@nsc.com
Deutsch Tel: +49 (0) 69 9508 6208
English Tel: +49 (0) 870 24 0 2171
Français Tel: +33 (0) 1 41 91 8790

**National Semiconductor Asia
Pacific Customer Support Center**
Email: ap.support@nsc.com

**National Semiconductor Japan
Customer Support Center**
Fax: 81-3-5639-7507
Email: jpn.feedback@nsc.com
Tel: 81-3-5639-7560