

P.T.C./CAD 10
 MAN 131 AUG 88
 REV 100
 ISSUE 00
 GK SERIES CHART 3
 PART 4 OF 8
 07 JAN 83
 RS
 21 SEP 82
 DM
 208976
 208982
 208983
 208984
 208985
 208986
 208987
 208988
 208989
 208990
 208991
 208992
 208993
 208994
 208995
 208996
 208997
 208998
 208999
 209000
 209001
 209002
 209003
 209004
 209005
 209006
 209007
 209008
 209009
 209010
 209011
 209012
 209013
 209014
 209015
 209016
 209017
 209018
 209019
 209020
 209021
 209022
 209023
 209024
 209025
 209026
 209027
 209028
 209029
 209030
 209031
 209032
 209033
 209034
 209035
 209036
 209037
 209038
 209039
 209040
 209041
 209042
 209043
 209044
 209045
 209046
 209047
 209048
 209049
 209050
 209051
 209052
 209053
 209054
 209055
 209056
 209057
 209058
 209059
 209060
 209061
 209062
 209063
 209064
 209065
 209066
 209067
 209068
 209069
 209070
 209071
 209072
 209073
 209074
 209075
 209076
 209077
 209078
 209079
 209080
 209081
 209082
 209083
 209084
 209085
 209086
 209087
 209088
 209089
 209090
 209091
 209092
 209093
 209094
 209095
 209096
 209097
 209098
 209099
 209100
 209101
 209102
 209103
 209104
 209105
 209106
 209107
 209108
 209109
 209110
 209111
 209112
 209113
 209114
 209115
 209116
 209117
 209118
 209119
 209120
 209121
 209122
 209123
 209124
 209125
 209126
 209127
 209128
 209129
 209130
 209131
 209132
 209133
 209134
 209135
 209136
 209137
 209138
 209139
 209140
 209141
 209142
 209143
 209144
 209145
 209146
 209147
 209148
 209149
 209150
 209151
 209152
 209153
 209154
 209155
 209156
 209157
 209158
 209159
 209160
 209161
 209162
 209163
 209164
 209165
 209166
 209167
 209168
 209169
 209170
 209171
 209172
 209173
 209174
 209175
 209176
 209177
 209178
 209179
 209180
 209181
 209182
 209183
 209184
 209185
 209186
 209187
 209188
 209189
 209190
 209191
 209192
 209193
 209194
 209195
 209196
 209197
 209198
 209199
 209200
 209201
 209202
 209203
 209204
 209205
 209206
 209207
 209208
 209209
 209210
 209211
 209212
 209213
 209214
 209215
 209216
 209217
 209218
 209219
 209220
 209221
 209222
 209223
 209224
 209225
 209226
 209227
 209228
 209229
 209230
 209231
 209232
 209233
 209234
 209235
 209236
 209237
 209238
 209239
 209240
 209241
 209242
 209243
 209244
 209245
 209246
 209247
 209248
 209249
 209250
 209251
 209252
 209253
 209254
 209255
 209256
 209257
 209258
 209259
 209260
 209261
 209262
 209263
 209264
 209265
 209266
 209267
 209268
 209269
 209270
 209271
 209272
 209273
 209274
 209275
 209276
 209277
 209278
 209279
 209280
 209281
 209282
 209283
 209284
 209285
 209286
 209287
 209288
 209289
 209290
 209291
 209292
 209293
 209294
 209295
 209296
 209297
 209298
 209299
 209300
 209301
 209302
 209303
 209304
 209305
 209306
 209307
 209308
 209309
 209310
 209311
 209312
 209313
 209314
 209315
 209316
 209317
 209318
 209319
 209320
 209321
 209322
 209323
 209324
 209325
 209326
 209327
 209328
 209329
 209330
 209331
 209332
 209333
 209334
 209335
 209336
 209337
 209338
 209339
 209340
 209341
 209342
 209343
 209344
 209345
 209346
 209347
 209348
 209349
 209350
 209351
 209352
 209353
 209354
 209355
 209356
 209357
 209358
 209359
 209360
 209361
 209362
 209363
 209364
 209365
 209366
 209367
 209368
 209369
 209370
 209371
 209372
 209373
 209374
 209375
 209376
 209377
 209378
 209379
 209380
 209381
 209382
 209383
 209384
 209385
 209386
 209387
 209388
 209389
 209390
 209391
 209392
 209393
 209394
 209395
 209396
 209397
 209398
 209399
 209400
 209401
 209402
 209403
 209404
 209405
 209406
 209407
 209408
 209409
 209410
 209411
 209412
 209413
 209414
 209415
 209416
 209417
 209418
 209419
 209420
 209421
 209422
 209423
 209424
 209425
 209426
 209427
 209428
 209429
 209430
 209431
 209432
 209433
 209434
 209435
 209436
 209437
 209438
 209439
 209440
 209441
 209442
 209443
 209444
 209445
 209446
 209447
 209448
 209449
 209450
 209451
 209452
 209453
 209454
 209455
 209456
 209457
 209458
 209459
 209460
 209461
 209462
 209463
 209464
 209465
 209466
 209467
 209468
 209469
 209470
 209471
 209472
 209473
 209474
 209475
 209476
 209477
 209478
 209479
 209480
 209481
 209482
 209483
 209484
 209485
 209486
 209487
 209488
 209489
 209490
 209491
 209492
 209493
 209494
 209495
 209496
 209497
 209498
 209499
 209500
 209501
 209502
 209503
 209504
 209505
 209506
 209507
 209508
 209509
 209510
 209511
 209512
 209513
 209514
 209515
 209516
 209517
 209518
 209519
 209520
 209521
 209522
 209523
 209524
 209525
 209526
 209527
 209528
 209529
 209530
 209531
 209532
 209533
 209534
 209535
 209536
 209537
 209538
 209539
 209540
 209541
 209542
 209543
 209544
 209545
 209546
 209547
 209548
 209549
 209550
 209551
 209552
 209553
 209554
 209555
 209556
 209557
 209558
 209559
 209560
 209561
 209562
 209563
 209564
 209565
 209566
 209567
 209568
 209569
 209570
 209571
 209572
 209573
 209574
 209575
 209576
 209577
 209578
 209579
 209580
 209581
 209582
 209583
 209584
 209585
 209586
 209587
 209588
 209589
 209590
 209591
 209592
 209593
 209594
 209595
 209596
 209597
 209598
 209599
 209600
 209601
 209602
 209603
 209604
 209605
 209606
 209607
 209608
 209609
 209610
 209611
 209612
 209613
 209614
 209615
 209616
 209617
 209618
 209619
 209620
 209621
 209622
 209623
 209624
 209625
 209626
 209627
 209628
 209629
 209630
 209631
 209632
 209633
 209634
 209635
 209636
 209637
 209638
 209639
 209640
 209641
 209642
 209643
 209644
 209645
 209646
 209647
 209648
 209649
 209650
 209651
 209652
 209653
 209654
 209655
 209656
 209657
 209658
 209659
 209660
 209661
 209662
 209663
 209664
 209665
 209666
 209667
 209668
 209669
 209670
 209671
 209672
 209673
 209674
 209675
 209676
 209677
 209678
 209679
 209680
 209681
 209682
 209683
 209684
 209685
 209686
 209687
 209688
 209689
 209690
 209691
 209692
 209693
 209694
 209695
 209696
 209697
 209698
 209699
 209700
 209701
 209702
 209703
 209704
 209705
 209706
 209707
 209708
 209709
 209710
 209711
 209712
 209713
 209714
 209715
 209716
 209717
 209718
 209719
 209720
 209721
 209722
 209723
 209724
 209725
 209726
 209727
 209728
 209729
 209730
 209731
 209732
 209733
 209734
 209735
 209736
 209737
 209738
 209739
 209740
 209741
 209742
 209743
 209744
 209745
 209746
 209747
 209748
 209749
 209750
 209751
 209752
 209753
 209754
 209755
 209756
 209757
 209758
 209759
 209760
 209761
 209762
 209763
 209764
 209765
 209766
 209767
 209768
 209769
 209770
 209771
 209772
 209773
 209774
 209775
 209776
 209777
 209778
 209779
 209780
 209781
 209782
 209783
 209784
 209785
 209786
 209787
 209788
 209789
 209790
 209791
 209792
 209793
 209794
 209795
 209796
 209797
 209798
 209799
 209800
 209801
 209802
 209803
 209804
 209805
 209806
 209807
 209808
 209809
 209810
 209811
 209812
 209813
 209814
 209815
 209816
 209817
 209818
 209819
 209820
 209821
 209822
 209823
 209824
 209825
 209826
 209827
 209828
 209829
 209830
 209831
 209832
 209833
 209834
 209835
 209836
 209837
 209838
 209839
 209840
 209841
 209842
 209843
 209844
 209845
 209846
 209847
 209848
 209849
 209850
 209851
 209852
 209853
 209854
 209855
 209856
 209857
 209858
 209859
 209860
 209861
 209862
 209863
 209864
 209865
 209866
 209867
 209868
 209869
 209870
 209871
 209872
 209873
 209874
 209875
 209876
 209877
 209878
 209879
 209880
 209881
 209882
 209883
 209884
 209885
 209886
 209887
 209888
 209889
 209890
 209891
 209892
 209893
 209894
 209895
 209896
 209897
 209898
 209899
 209900
 209901
 209902
 209903
 209904
 209905
 209906
 209907
 209908
 209909
 209910
 209911
 209912
 209913
 209914
 209915
 209916
 209917
 209918
 209919
 209920
 209921
 209922
 209923
 209924
 209925
 209926
 209927
 209928
 209929
 209930
 209931
 209932
 209933
 209934
 209935
 209936
 209937
 209938
 209939
 209940
 209941
 209942
 209943
 209944
 209945
 209946
 209947
 209948
 209949
 209950
 209951
 209952
 209953
 209954
 209955
 209956
 209957
 209958
 209959
 209960
 209961
 209962
 209963
 209964
 209965
 209966
 209967
 209968
 209969
 209970
 209971
 209972
 209973
 209974
 209975
 209976
 209977
 209978
 209979
 209980
 209981
 209982
 209983
 209984
 209985
 209986
 209987
 209988
 209989
 209990
 209991
 209992
 209993
 209994
 209995
 209996
 209997
 209998
 209999
 210000

M GK SERIES CHART 3

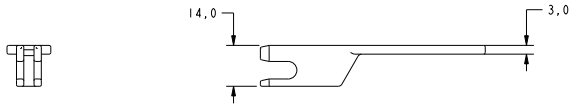

KEY CODE 6

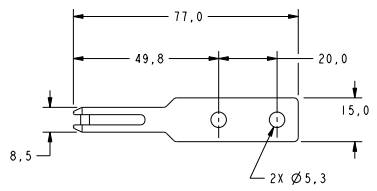
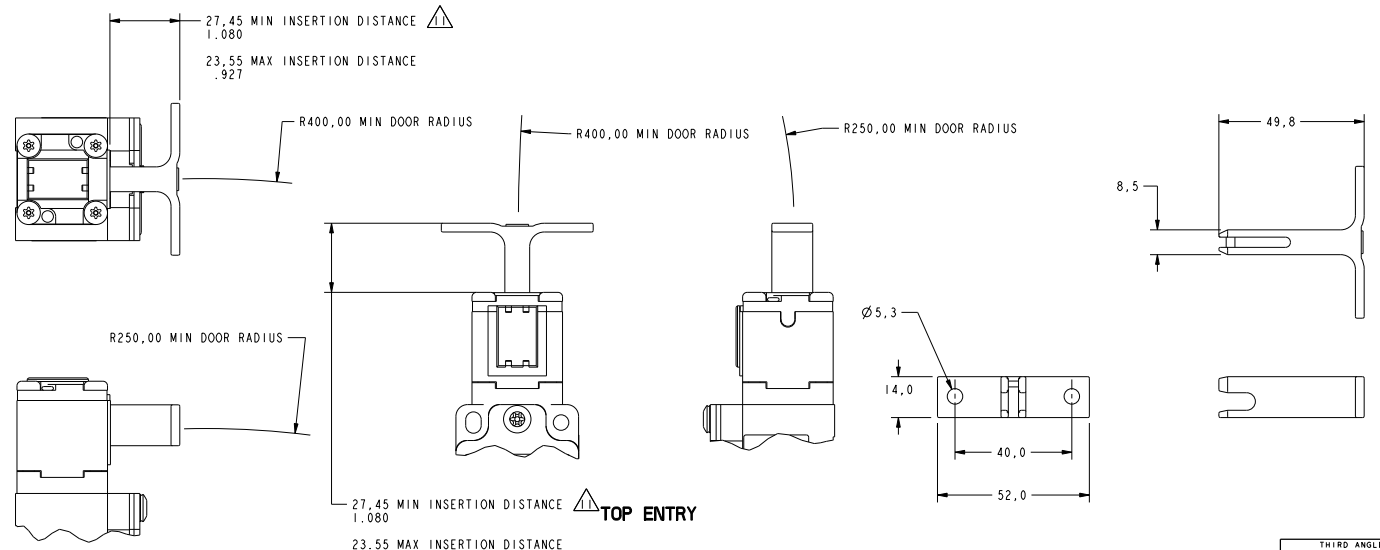

FRONT ENTRY

KEY CODE 7

THIS DRAWING COVERS A PROPRIETARY ITEM AND IS THE PROPERTY OF MICRO SWITCH, A DIVISION OF HONEYWELL. THIS DRAWING IS NOT TO BE COPIED OR USED WITHOUT THE APPROVAL OF MICRO SWITCH.

MICROSWITCH
a Honeywell Division

SWITCH - LIMIT

CATALOG LISTING
GK SERIES CHART 3

THIRD ANGLE PROJECTION		
SCALE FULL		
DO NOT SCALE PRINT		
UNLESS OTHERWISE SPECIFIED TOLERANCES ARE		
ONE PLACE	(.01)	±.030
TWO PLACES	(.00)	±.015
THREE PLACES	(.000)	±.005
ANGLES		±
WEIGHT APPROX .5 KG / 1 LB		

ANSI Y14.5M-1982 APPLIES

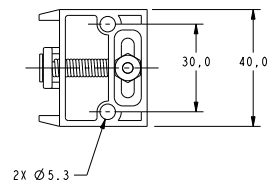
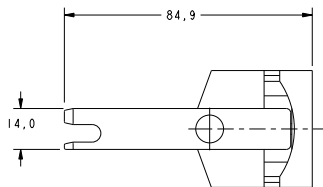
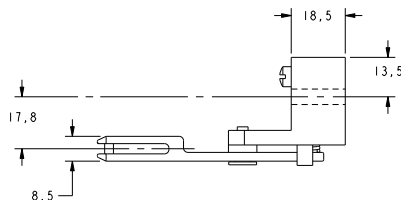
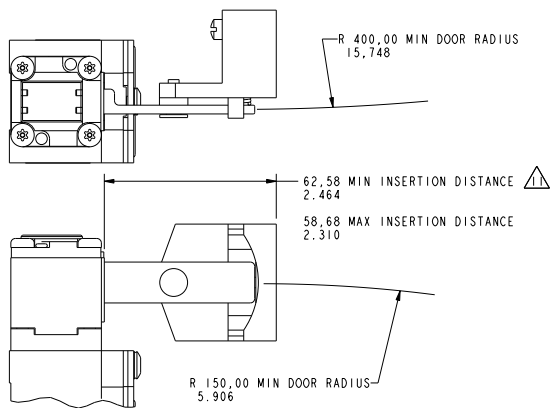

FRONT ENTRY

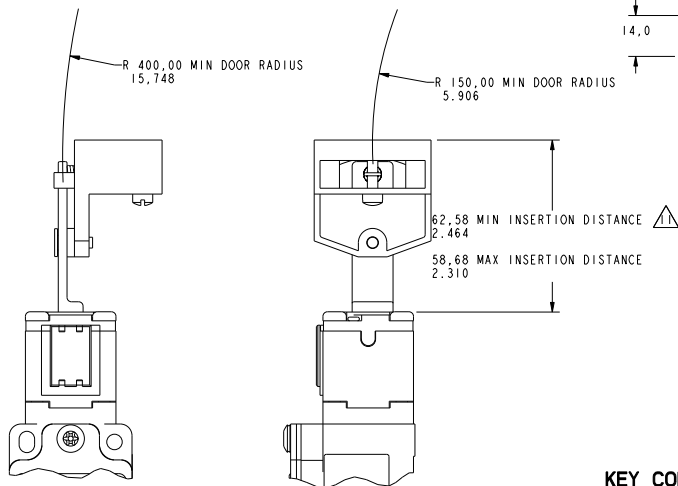

TOP ENTRY

KEY CODE 8

THIS DRAWING COVERS A PROPRIETARY ITEM AND IS THE PROPERTY OF MICRO SWITCH, A DIVISION OF HONEYWELL. THIS DRAWING IS NOT TO BE COPIED OR USED WITHOUT THE APPROVAL OF MICRO SWITCH.

MICROSWITCH a Honeywell Division <small>FED. MFG. CODE 91329</small>	SWITCH - LIMIT	CATALOG LISTING GK SERIES CHART 3
		WEIGHT APPROX. .5 KG / 1 LB

THIRD ANGLE PROJECTION		
SCALE	FULL	
DO NOT SCALE PRINT		
UNLESS OTHERWISE SPECIFIED TOLERANCES ARE		
ONE PLACE	(.01)	±.030
TWO PLACES	(.001)	±.015
THREE PLACES	(.0001)	±.005
ANGLES		±

P.T.C./CAD 130
 MAN T SEP 88
 REV 15 0885
 A 208724
 B 208725
 C 208726
 D 208727
 E 208728
 F 208729
 G 208730
 H 208731
 I 208732
 J 208733
 K 208734
 L 208735
 M 208736
 N 208737
 O 208738
 P 208739
 Q 208740
 R 208741
 S 208742
 T 208743
 U 208744
 V 208745
 W 208746
 X 208747
 Y 208748
 Z 208749
 AA 208750
 AB 208751
 AC 208752
 AD 208753
 AE 208754
 AF 208755
 AG 208756
 AH 208757
 AI 208758
 AJ 208759
 AK 208760
 AL 208761
 AM 208762
 AN 208763
 AO 208764
 AP 208765
 AQ 208766
 AR 208767
 AS 208768
 AT 208769
 AU 208770
 AV 208771
 AW 208772
 AX 208773
 AY 208774
 AZ 208775
 BA 208776
 BB 208777
 BC 208778
 BD 208779
 BE 208780
 BF 208781
 BG 208782
 BH 208783
 BI 208784
 BJ 208785
 BK 208786
 BL 208787
 BM 208788
 BN 208789
 BO 208790
 BP 208791
 BQ 208792
 BR 208793
 BS 208794
 BT 208795
 BU 208796
 BV 208797
 BW 208798
 BX 208799
 BY 208800
 BZ 208801
 CA 208802
 CB 208803
 CC 208804
 CD 208805
 CE 208806
 CF 208807
 CG 208808
 CH 208809
 CI 208810
 CJ 208811
 CK 208812
 CL 208813
 CM 208814
 CN 208815
 CO 208816
 CP 208817
 CQ 208818
 CR 208819
 CS 208820
 CT 208821
 CU 208822
 CV 208823
 CW 208824
 CX 208825
 CY 208826
 CZ 208827
 DA 208828
 DB 208829
 DC 208830
 DD 208831
 DE 208832
 DF 208833
 DG 208834
 DH 208835
 DI 208836
 DJ 208837
 DK 208838
 DL 208839
 DM 208840
 DN 208841
 DO 208842
 DP 208843
 DQ 208844
 DR 208845
 DS 208846
 DT 208847
 DU 208848
 DV 208849
 DW 208850
 DX 208851
 DY 208852
 DZ 208853
 EA 208854
 EB 208855
 EC 208856
 ED 208857
 EE 208858
 EF 208859
 EG 208860
 EH 208861
 EI 208862
 EJ 208863
 EK 208864
 EL 208865
 EM 208866
 EN 208867
 EO 208868
 EP 208869
 EQ 208870
 ER 208871
 ES 208872
 ET 208873
 EU 208874
 EV 208875
 EW 208876
 EX 208877
 EY 208878
 EZ 208879
 FA 208880
 FB 208881
 FC 208882
 FD 208883
 FE 208884
 FF 208885
 FG 208886
 FH 208887
 FI 208888
 FJ 208889
 FK 208890
 FL 208891
 FM 208892
 FN 208893
 FO 208894
 FP 208895
 FQ 208896
 FR 208897
 FS 208898
 FT 208899
 FU 208900
 FV 208901
 FW 208902
 FX 208903
 FY 208904
 FZ 208905
 GA 208906
 GB 208907
 GC 208908
 GD 208909
 GE 208910
 GF 208911
 GH 208912
 GI 208913
 GJ 208914
 GK 208915
 GL 208916
 GM 208917
 GN 208918
 GO 208919
 GP 208920
 GQ 208921
 GR 208922
 GS 208923
 GT 208924
 GU 208925
 GV 208926
 GW 208927
 GX 208928
 GY 208929
 GZ 208930
 HA 208931
 HB 208932
 HC 208933
 HD 208934
 HE 208935
 HF 208936
 HG 208937
 HH 208938
 HI 208939
 HJ 208940
 HK 208941
 HL 208942
 HM 208943
 HN 208944
 HO 208945
 HP 208946
 HQ 208947
 HR 208948
 HS 208949
 HT 208950
 HU 208951
 HV 208952
 HW 208953
 HX 208954
 HY 208955
 HZ 208956
 IA 208957
 IB 208958
 IC 208959
 ID 208960
 IE 208961
 IF 208962
 IG 208963
 IH 208964
 II 208965
 IJ 208966
 IK 208967
 IL 208968
 IM 208969
 IN 208970
 IO 208971
 IP 208972
 IQ 208973
 IR 208974
 IS 208975
 IT 208976
 IU 208977
 IV 208978
 IW 208979
 IX 208980
 IY 208981
 IZ 208982
 JA 208983
 JB 208984
 JC 208985
 JD 208986
 JE 208987
 JF 208988
 JG 208989
 JH 208990
 JI 208991
 JJ 208992
 JK 208993
 JL 208994
 JM 208995
 JN 208996
 JO 208997
 JP 208998
 JQ 208999
 JR 209000
 JS 209001
 JT 209002
 JU 209003
 JV 209004
 JW 209005
 JX 209006
 JY 209007
 JZ 209008
 KA 209009
 KB 209010
 KC 209011
 KD 209012
 KE 209013
 KF 209014
 KG 209015
 KH 209016
 KI 209017
 KJ 209018
 KK 209019
 KL 209020
 KM 209021
 KN 209022
 KO 209023
 KP 209024
 KQ 209025
 KR 209026
 KS 209027
 KT 209028
 KU 209029
 KV 209030
 KW 209031
 KX 209032
 KY 209033
 KZ 209034
 LA 209035
 LB 209036
 LC 209037
 LD 209038
 LE 209039
 LF 209040
 LG 209041
 LH 209042
 LI 209043
 LJ 209044
 LK 209045
 LL 209046
 LM 209047
 LN 209048
 LO 209049
 LP 209050
 LQ 209051
 LR 209052
 LS 209053
 LT 209054
 LU 209055
 LV 209056
 LW 209057
 LX 209058
 LY 209059
 LZ 209060
 MA 209061
 MB 209062
 MC 209063
 MD 209064
 ME 209065
 MF 209066
 MG 209067
 MH 209068
 MI 209069
 MJ 209070
 MK 209071
 ML 209072
 MM 209073
 MN 209074
 MO 209075
 MP 209076
 MQ 209077
 MR 209078
 MS 209079
 MT 209080
 MU 209081
 MV 209082
 MW 209083
 MX 209084
 MY 209085
 MZ 209086
 NA 209087
 NB 209088
 NC 209089
 ND 209090
 NE 209091
 NF 209092
 NG 209093
 NH 209094
 NI 209095
 NJ 209096
 NK 209097
 NL 209098
 NM 209099
 NO 209100
 NP 209101
 NQ 209102
 NR 209103
 NS 209104
 NT 209105
 NU 209106
 NV 209107
 NW 209108
 NX 209109
 NY 209110
 NZ 209111
 OA 209112
 OB 209113
 OC 209114
 OD 209115
 OE 209116
 OF 209117
 OG 209118
 OH 209119
 OI 209120
 OJ 209121
 OK 209122
 OL 209123
 OM 209124
 ON 209125
 OO 209126
 OP 209127
 OQ 209128
 OR 209129
 OS 209130
 OT 209131
 OU 209132
 OV 209133
 OW 209134
 OX 209135
 OY 209136
 OZ 209137
 PA 209138
 PB 209139
 PC 209140
 PD 209141
 PE 209142
 PF 209143
 PG 209144
 PH 209145
 PI 209146
 PJ 209147
 PK 209148
 PL 209149
 PM 209150
 PN 209151
 PO 209152
 PP 209153
 PQ 209154
 PR 209155
 PS 209156
 PT 209157
 PU 209158
 PV 209159
 PW 209160
 PX 209161
 PY 209162
 PZ 209163
 QA 209164
 QB 209165
 QC 209166
 QD 209167
 QE 209168
 QF 209169
 QG 209170
 QH 209171
 QI 209172
 QJ 209173
 QK 209174
 QL 209175
 QM 209176
 QN 209177
 QO 209178
 QP 209179
 QQ 209180
 QR 209181
 QS 209182
 QT 209183
 QU 209184
 QV 209185
 QW 209186
 QX 209187
 QY 209188
 QZ 209189
 RA 209190
 RB 209191
 RC 209192
 RD 209193
 RE 209194
 RF 209195
 RG 209196
 RH 209197
 RI 209198
 RJ 209199
 RK 209200
 RL 209201
 RM 209202
 RN 209203
 RO 209204
 RP 209205
 RQ 209206
 RR 209207
 RS 209208
 RT 209209
 RU 209210
 RV 209211
 RW 209212
 RX 209213
 RY 209214
 RZ 209215
 SA 209216
 SB 209217
 SC 209218
 SD 209219
 SE 209220
 SF 209221
 SG 209222
 SH 209223
 SI 209224
 SJ 209225
 SK 209226
 SL 209227
 SM 209228
 SN 209229
 SO 209230
 SP 209231
 SQ 209232
 SR 209233
 SS 209234
 ST 209235
 SU 209236
 SV 209237
 SW 209238
 SX 209239
 SY 209240
 SZ 209241
 TA 209242
 TB 209243
 TC 209244
 TD 209245
 TE 209246
 TF 209247
 TG 209248
 TH 209249
 TI 209250
 TJ 209251
 TK 209252
 TL 209253
 TM 209254
 TN 209255
 TO 209256
 TP 209257
 TQ 209258
 TR 209259
 TS 209260
 TU 209261
 TV 209262
 TW 209263
 TX 209264
 TY 209265
 TZ 209266
 UA 209267
 UB 209268
 UC 209269
 UD 209270
 UE 209271
 UF 209272
 UG 209273
 UH 209274
 UI 209275
 UJ 209276
 UK 209277
 UL 209278
 UM 209279
 UN 209280
 UO 209281
 UP 209282
 UQ 209283
 UR 209284
 US 209285
 UT 209286
 UV 209287
 UW 209288
 UX 209289
 UY 209290
 UZ 209291
 VA 209292
 VB 209293
 VC 209294
 VD 209295
 VE 209296
 VF 209297
 VG 209298
 VH 209299
 VI 209300
 VJ 209301
 VK 209302
 VL 209303
 VM 209304
 VN 209305
 VO 209306
 VP 209307
 VQ 209308
 VR 209309
 VS 209310
 VT 209311
 VU 209312
 VV 209313
 VW 209314
 VX 209315
 VY 209316
 VZ 209317
 WA 209318
 WB 209319
 WC 209320
 WD 209321
 WE 209322
 WF 209323
 WG 209324
 WH 209325
 WI 209326
 WJ 209327
 WK 209328
 WL 209329
 WM 209330
 WN 209331
 WO 209332
 WP 209333
 WQ 209334
 WR 209335
 WS 209336
 WT 209337
 WU 209338
 WV 209339
 WX 209340
 WY 209341
 WZ 209342
 XA 209343
 XB 209344
 XC 209345
 XD 209346
 XE 209347
 XF 209348
 XG 209349
 XH 209350
 XI 209351
 XJ 209352
 XK 209353
 XL 209354
 XM 209355
 XN 209356
 XO 209357
 XP 209358
 XQ 209359
 XR 209360
 XS 209361
 XT 209362
 XU 209363
 XV 209364
 XW 209365
 XX 209366
 XY 209367
 XZ 209368
 YA 209369
 YB 209370
 YC 209371
 YD 209372
 YE 209373
 YF 209374
 YG 209375
 YH 209376
 YI 209377
 YJ 209378
 YK 209379
 YL 209380
 YM 209381
 YN 209382
 YO 209383
 YP 209384
 YQ 209385
 YR 209386
 YS 209387
 YT 209388
 YU 209389
 YV 209390
 YW 209391
 YX 209392
 YZ 209393
 ZA 209394
 ZB 209395
 ZC 209396
 ZD 209397
 ZE 209398
 ZF 209399
 ZG 209400
 ZH 209401
 ZI 209402
 ZJ 209403
 ZK 209404
 ZL 209405
 ZM 209406
 ZN 209407
 ZO 209408
 ZP 209409
 ZQ 209410
 ZR 209411
 ZS 209412
 ZT 209413
 ZU 209414
 ZV 209415
 ZW 209416
 ZX 209417
 ZY 209418
 ZZ 209419

ANSI Y14.5M-1982 APPLIES

MICRO SWITCH
a Honeywell Division
FED. MFG. CODE 91929

SWITCH - DOOR INTERLOCK

CATALOG LISTING
GK SERIES CHART 3

THIS DRAWING COVERS A PROPRIETARY ITEM AND IS THE PROPERTY OF MICRO SWITCH, A DIVISION OF HONEYWELL. THIS DRAWING IS NOT TO BE COPIED OR USED WITHOUT THE APPROVAL OF MICRO SWITCH

MODIFICATION CODE: FW

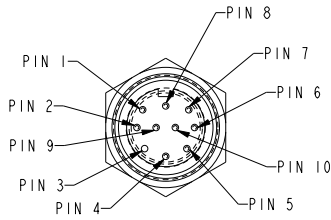

10-PIN CONNECTOR $\triangle 2$

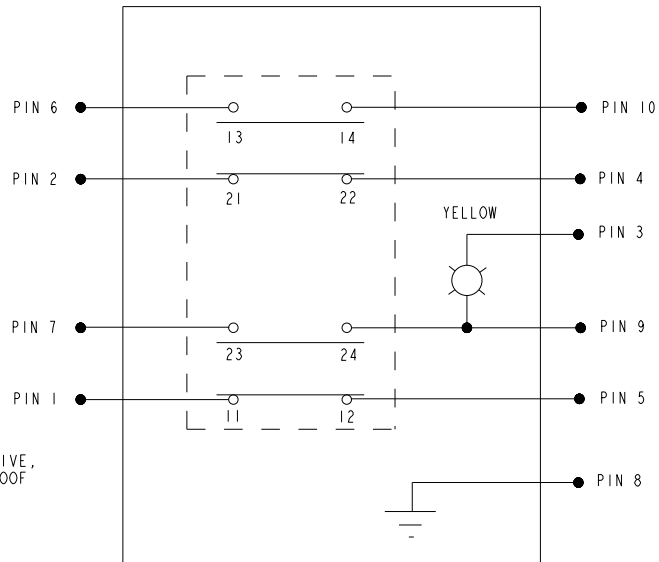

**BASIC SWITCH TO 10-PIN CONNECTOR
CIRCUIT DIAGRAM
DIAGRAM SHOWN WITH KEY INSERTED**

NOTES

- 1 - THE TWO COVER SCREWS ARE COMBINATION DRIVE, THE FOUR HEAD SCREWS ARE T-15 TAMPER PROOF TORX DRIVE (DRIVER BIT IS PROVIDED)



ISSUE	30	RS	07 JAN 09	RELEASE NO. PR-23758	REPLACES
	CATALOG LISTING GK SERIES CHART 3 PAGE 8 OF 8				
REVISIONS	A	206394	SM	21 SEP 06	CHECK
	B	204443	JLH	21 SEP 02	DVM
	C	206976	JLH	20 JUN 02	SAV
	D	207003	SM	18 JAN 00	CHECK
	E	207211	SM	18 JAN 00	CHECK
	F	207576	SM	18 JAN 00	CHECK
	G	0000385	SM	18 JAN 00	CHECK
	H	0025008	SM	18 JAN 00	CHECK
	J	0047425	SM	07 JAN 09	CHECK
PTC/CAD	3D				
DRAWN					

ANSI Y14.5M-1982 APPLIES

THIRD ANGLE PROJECTION			
SCALE	NONE		
DO NOT SCALE PRINT			
TOLERANCES			
APPLY TO DESIGN UNITS. CONVERSIONS ARE ONLY FOR REFERENCE, UNLESS NOTES. TOLERANCES ARE:			
	FR.	TOL.	FR.
	mm	mm ±	in
NO PLACES	±	1/.04	±1
ONE PLACE	±.1	0.0750	±.01
TWO PLACES	±.01	0.15700	±.001
THREE PLACES	±.001	0.0015	±.0001
ANGLES	°		
DESIGN UNITS	SI METRIC	US CUSTOMARY	
	<input checked="" type="checkbox"/>	<input type="checkbox"/>	
WEIGHT	0,4 KG / 1LB		