

# HFCT-5710L/LP

## Small Form Factor Pluggable LC Optical Transceivers



## Data Sheet



### Description

The HFCT-5710L/LP Small Form Factor Pluggable LC optical transceiver is compliant with both the IEEE 802.3Z (1000BASE-LX) and Small Form Factor Pluggable (SFP) Multi-Source Agreement (MSA) specifications. The transceiver is intended for premise, public and access networking equipment. The product transmits data over single mode cable for a link distance of 10 km, which is in excess of the standard.

Typical applications for this product are switch to switch, switch backbones, and high-speed interface for server farms. Emerging applications of this product include high-density metro access switch GbE connections.

### Related Products

- HFBR-5710L/LP: 850 nm 1.25 GBd 3.3 V multimode SFP Gigabit Ethernet transceiver
- HDMP-1687: Quad Channel SerDes IC 1.25 GBd Ethernet
- HDMP-1646A: Single Channel SerDes IC for 1.25 GBd Ethernet

### Features

- IEEE 802.3Z Gigabit Ethernet (1.25 GBd) 1000BASE-LX compliant
- Small Form Factor Pluggable (SFP) Multi-Source Agreement (MSA) compliant
- Manufactured in an ISO 9001 compliant facility
- Hot-pluggable
- HFCT-5710LP bail wire de-latch  
HFCT-5710L standard de-latch
- +3.3 V dc power supply
- 1310 nm longwave laser
- Eye safety certified:
  - US 21 CFR(J)
  - IEC 60825-1 (+All)
- LC-Duplex fiber connector compatible
- Fiber compatibility:
  - 2m to 10km with 9 $\mu$ m SM fiber
  - 2m to 550m with 50 $\mu$ m MM fiber
  - 2m to 550m with 62.5 $\mu$ m MM fiber

### Applications

- Switch to switch applications
- Switched backplane applications
- High Speed Interface for server farms
- Metro access switch GbE connections

## General Features

1000BASE-LX Compliance:

The HFCT-5710L/LP is compliant with the IEEE 802.3Z (2000 Edition) Physical Medium Dependent (PMD) sublayer and baseband medium, type 1000BASE-LX (Long Wavelength Laser) description. This includes specifications for the signal coding, optical fiber and connector types, optical and electrical transmitter characteristics, optical and electrical receiver characteristics, jitter characteristics, and compliance testing methodology for the aforementioned.

This transceiver is capable of implementing both Single Mode (SM) and Multimode (MM) optical fiber applications in that order of precedence in the event of conflicting specifications. In addition, the SM link type exceeds the 2 m to 5 km 1000BASE-LX specification by achieving compliance over 2 m to 10 km. The MM link type meets the 50  $\mu\text{m}$  and 62.5  $\mu\text{m}$  MMF specification when used with an "offset launch" fiber.

The optical connector is LC duplex.

There is no governing environmental specification in IEEE 802.3Z therefore the environmental specifications contained in this product definition take precedence. Compliance over all operating conditions defined in this document is implied except where specifically noted.

SFP MSA Compliance:

The product package is compliant with the SFP MSA with the LC connector option. The SFP MSA includes specifications for mechanical packaging and performance as well as dc, ac and control signal timing and performance.

The power supply is 3.3 V dc.

The High Speed I/O (HSIO) signal interface is a Low Voltage Differential type. It is ac coupled and terminated internally to the module. The internal termination is a 100 Ohm differential load.

## Operating Temperature

The HFCT-5710L/LP has an operating case temperature of -10 to +85°C.

## Serial Identification (EEPROM)

The HFCT-5710L/LP is compliant with the SFP MSA, which defines the serial identification protocol. This protocol uses the 2-wire serial CMOS E2PROM protocol of the ATMEL AT24C01A or similar. MSA compliant, example contents of the HFCT-5710L/LP serial ID memory are defined in Table 9.

## Eye Safety

For details of product compliance, see Table 1.

## De-latch Mechanism

The de-latching mechanism uses the same design as the MM HFBR-5710L. The HFCT-5710L/LP is designed with an MSA compliant standard de-latch and an optional de-latch for Belly-to-Belly operation. The optional de-latch has been slightly modified outside of MSA compliance to optimize the mechanical performance of the product. These modifications do not interfere with the overall form, fit and function as specified by the SFP MSA.

## Power Supply Noise

The HFCT-5710L/LP can withstand an injection of PSN on the  $V_{CC}$  lines of 100 mV ac without a degradation in eye mask margin to 10% on the transmitter and a 1 dB sensitivity penalty on the receiver. This occurs when the product is used in conjunction with the MSA recommended power supply filter shown in Figure 1.

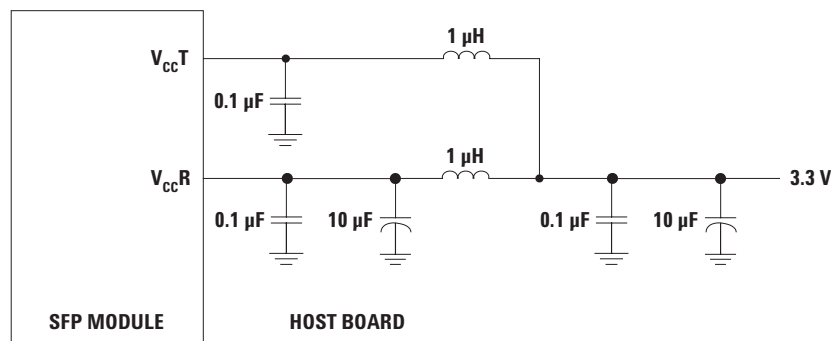

Figure 1 - MSA required power supply filter

## Regulatory Compliance

Feature	Test Method	Performance
Electrostatic Discharge (ESD) to the Electrical Pins	MIL-STD-883C Method 3015	Class 2 (2000 Volts)
Electrostatic Discharge (ESD) to the Duplex LC Receptacle	Bellcore GR1089-CORE	25 kV Air Discharge 10 Zaps at 8 kV (contact discharge) on the electrical face-plate on panel.
Electromagnetic Interference (EMI)	FCC Class B	Applications with high SFP port counts are expected to be compliant; however, margins are dependent on customer board and chassis design.
Immunity	Variation of IEC 61000-4-3	No measurable effect from a 10 V/m field swept from 80 to 1000 MHz applied to the transceiver without a chassis enclosure.
Eye Safety	US FDA CDRH AEL Class 1EN (IEC 60825-1, 2, EN60950 Class 1)	CDRH certification # 9521220-52 TUV file # 933/510206/02UL file # E173874
Component Recognition	Underwriter's Laboratories and Canadian Standards Association Joint Component Recognition for Information Technology Equipment Including Electrical Business Equipment	UL file # E173874

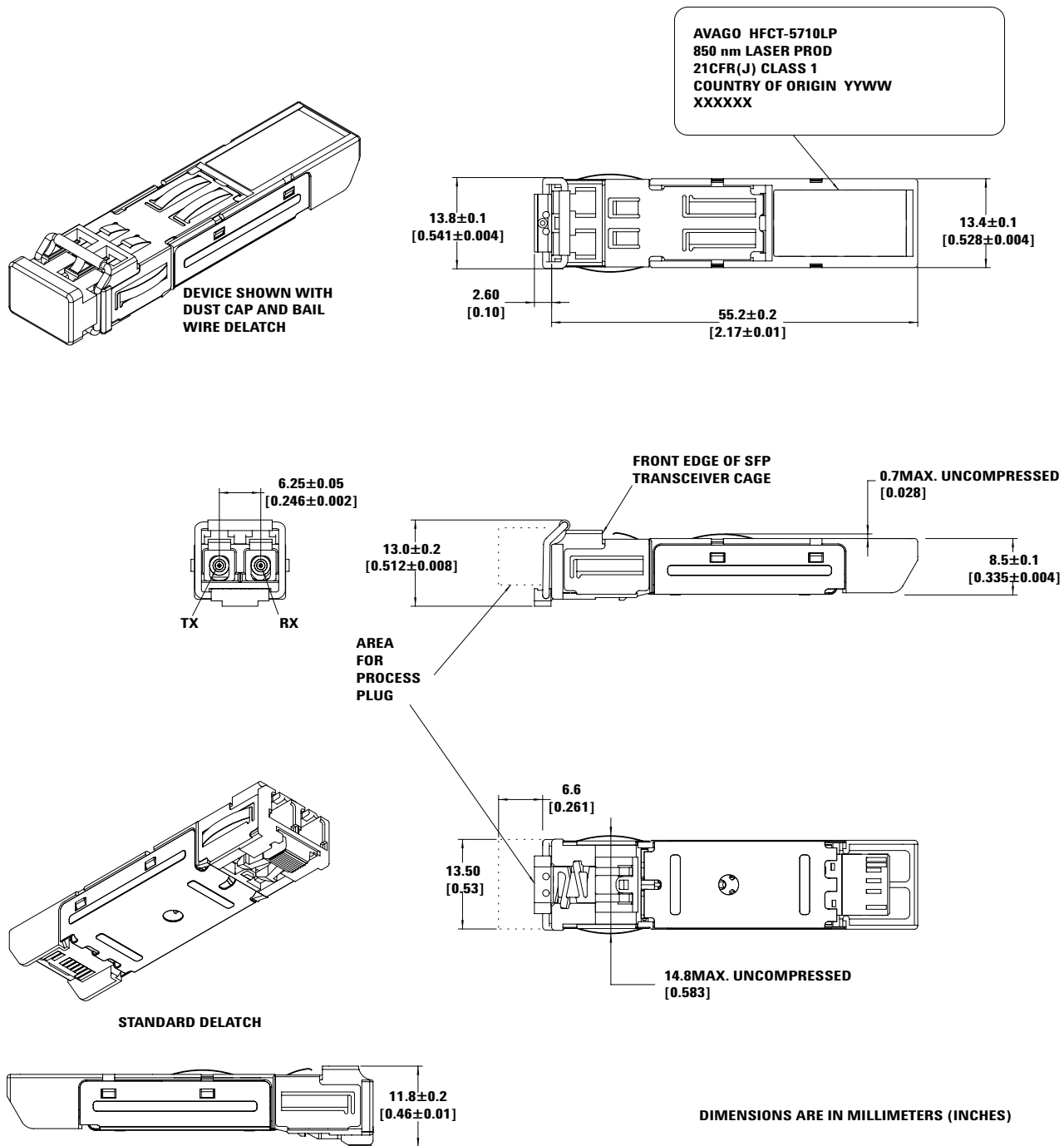

Figure 2a. Drawing of SFP Transceiver

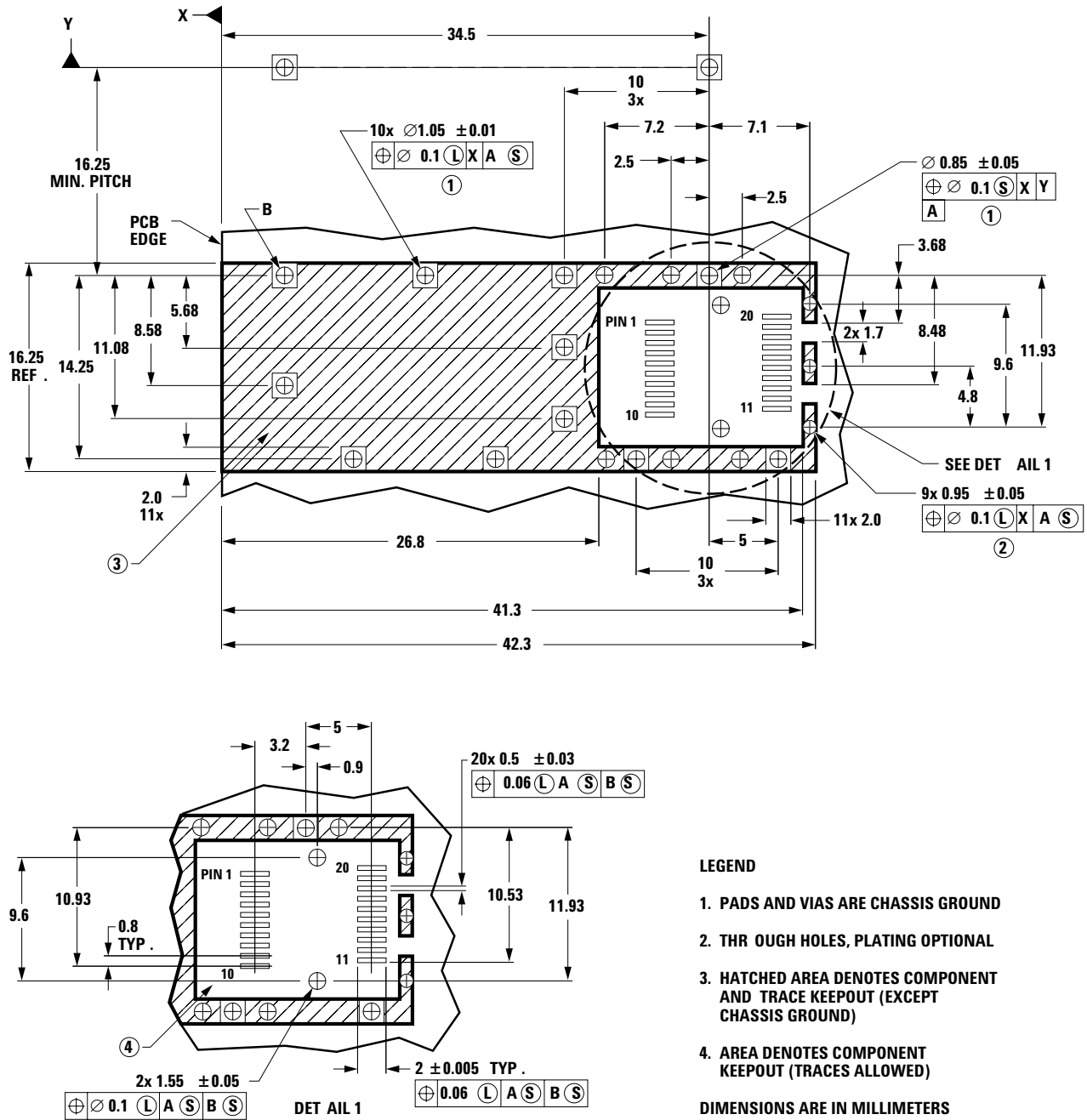
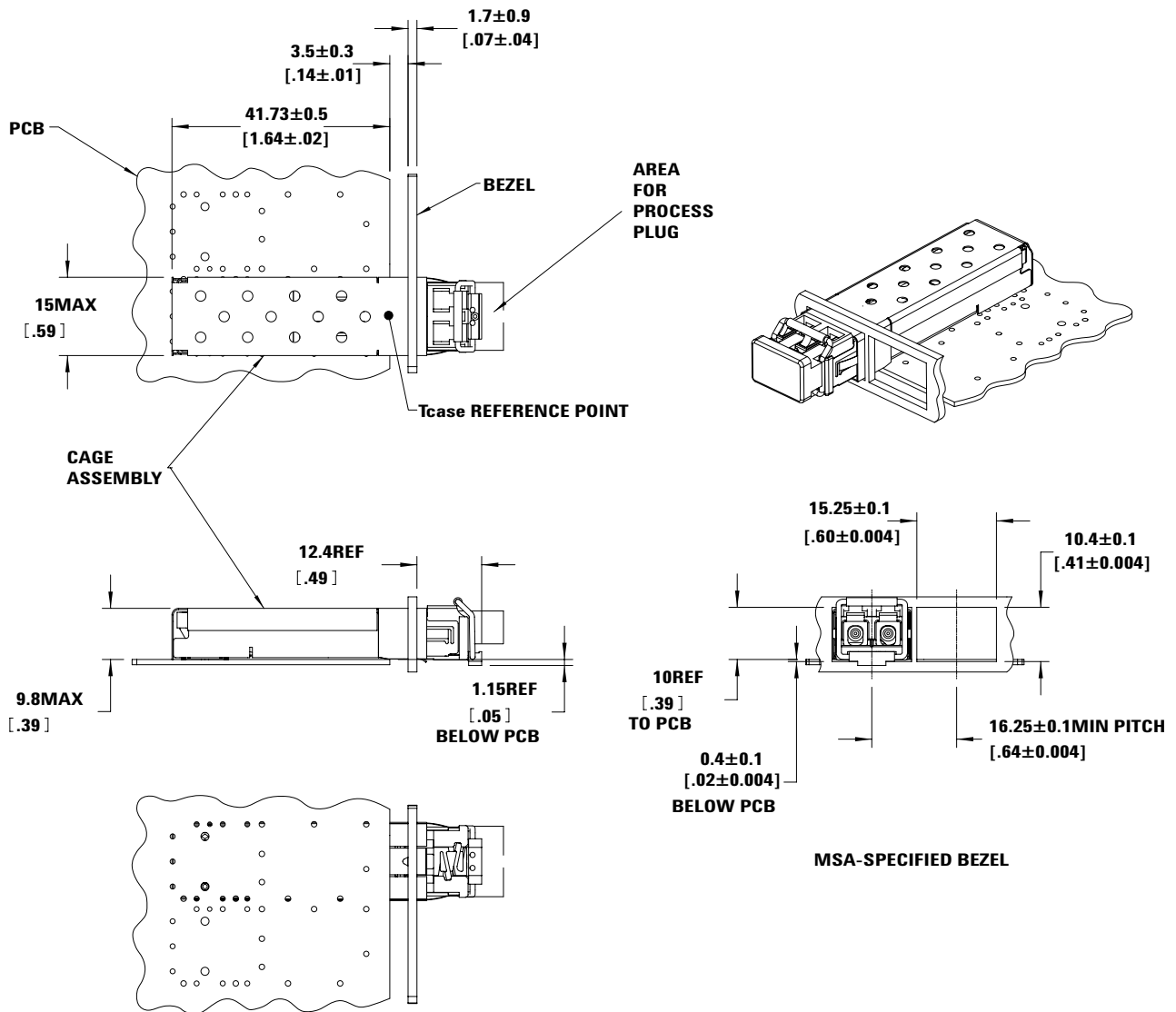

Figure 2b. SFP host board mechanical layout



**DIMENSIONS ARE IN MILLIMETERS [INCHES].**

Figure 2c.

## Pin-out Table

The pin arrangement and definition of this product meets SFP MSA. Table 2 lists the pin description.

Pin	Name	Function/Description	MSA Notes
1	VeeT	Transmitter Ground	
2	TX Fault	Transmitter Fault Indication	Note 1
3	TX Disable	Transmitter Disable - Module disables on high or open	Note 2
4	MOD-DEF2	Module Definition 2 - Two wire serial ID interface	Note 3
5	MOD-DEF1	Module Definition 1 - Two wire serial ID interface	Note 3
6	MOD-DEF0	Module Definition 0 - Grounded in module	Note 3
7	Rate Select	Not Connected	
8	LOS	Loss of Signal	Note 4
9	VeeR	Receiver Ground	
10	VeeR	Receiver Ground	
11	VeeR	Receiver Ground	
12	RD-	Inverse Received Data Out	Note 5
13	RD+	Received Data Out	Note 5
14	VeeR	Receiver Ground	
15	VccR	Receiver Power - 3.3 V $\pm$ 5%	Note 6
16	VccT	Transmitter Power - 3.3 V $\pm$ 5%	Note 6
17	VeeT	Transmitter Ground	
18	TD+	Transmitter Data In	Note 7
19	TD-	Inverse Transmitter Data In	Note 7
20	VeeT	Transmitter Ground	

### Notes:

- TX Fault is an open collector/drain output, which should be pulled up with a 4.7K – 10K resistor on the host board. Pull up voltage between 2.0V and VccT, R+0.3V. When high, output indicates a laser fault of some kind. Low indicates normal operation. In the low state, the output will be pulled to < 0.8V.
- TX Disable input is used to shut down the laser output per the state table below with an external 4.7 - 10 K $\Omega$  pull-up resistor.
 

Low (0 - 0.8 V):	Transmitter on
Between (0.8 V and 2.0 V):	Undefined
High (2.0 - 3.465 V):	Transmitter Disabled
Open:	Transmitter Disabled
- MOD-DEF 0,1,2. These are the module definition pins. They should be pulled up with a 4.7 - 10 K $\Omega$  resistor on the host board to a supply less than VccT +0.3 V or VccR+0.3 V.
  - MOD-DEF 0 is grounded by the module to indicate that the module is present
  - MOD-DEF 1 is clock line of two wire serial interface for optional serial ID
  - MOD-DEF 2 is data line of two wire serial interface for optional serial ID
- LOS (Loss of Signal) is an open collector/drain output which should be pulled up externally with a 4.7K - 10 K $\Omega$  resistor on the host board to a supply < VccT,R+0.3 V. When high, this output indicates the received optical power is below the worst case receiver sensitivity (as defined by the standard in use). Low indicates normal operation. In the low state, the output will be pulled to < 0.8 V.
- RD-/+ : These are the differential receiver outputs. They are ac coupled 100 $\Omega$  differential lines which should be terminated with 100 $\Omega$  differential at the user SERDES. The ac coupling is done inside the module and is thus not required on the host board. The voltage swing on these lines will be between 370 and 1600 mV differential (185 - 800 mV single ended) when properly terminated.
- VccR and VccT are the receiver and transmitter power supplies. They are defined as 3.135 - 3.465 V at the SFP connector pin. The maximum supply current is 300 mA and the associated inrush current will be no more than 30 mA above steady state after 500 nanoseconds.
- TD-/+ : These are the differential transmitter inputs. They are ac coupled differential lines with 100 $\Omega$  differential termination inside the module. The ac coupling is done inside the module and is thus not required on the host board. The inputs will accept differential swings of 500 - 2400 mV (250 - 1000 mV single ended), though it is recommended that values between 500 and 1200 mV differential (250 - 600 mV single ended) be used for best EMI performance.

**Table 3 - Absolute Maximum Ratings**

Absolute maximum ratings are those values beyond which functional performance is not intended, device reliability is not implied, and damage to the device may occur.

Parameter	Symbol	Minimum	Maximum	Unit	Notes
Storage Temperature (non-operating)	T <sub>S</sub>	-40	+85	°C	
Relative Humidity	RH	5	85	%	
Supply Voltage	V <sub>CC</sub>	-0.5	3.63	V	
Input Voltage on any Pin	V <sub>I</sub>	-0.5	V <sub>CC</sub>	V	

**Table 4 - Recommended Operating Conditions**

Typical operating conditions are those values for which functional performance and device reliability is implied.

Parameter	Symbol	Minimum	Typical	Maximum	Unit	Notes
Case Operating Temperature	T <sub>A</sub>	-10	+25	+85	°C	
Supply Voltage	V <sub>CC</sub>	3.14	3.3	3.47	V	

**Table 5 - Transceiver Electrical Characteristics**

Parameter	Symbol	Minimum	Typical	Maximum	Unit	Notes
Module supply current	I <sub>CC</sub>		200	240	mA	1
Power Dissipation	P <sub>DISS</sub>		660	762.3	mW	1
<b>AC Electrical Characteristics</b>						
Power Supply Noise Rejection (peak - peak)	PSNR	100			mV	2
Inrush Current				30	mA	3
<b>DC Electrical Characteristics</b>						
<b>Sense Outputs:</b>	V <sub>OH</sub>	2.0		V <sub>CC</sub> T, R+0.3	V	4
Transmit Fault (TX_FAULT)						
Loss of Signal (LOS) MOD-DEF2	V <sub>OL</sub>			0.8	V	
<b>Control Inputs:</b>	V <sub>IH</sub>	2.0		V <sub>CC</sub>	V	4, 5
Transmitter Disable (TX_DISABLE)						
MOD-DEF1, 2	V <sub>IL</sub>			0.8	V	
<b>Data Input:</b> Transmitter Differential Input Voltage (TD+/-)	V <sub>I</sub>	500		2000	mV	6
<b>Data Output:</b> Receiver Differential Output Voltage (RD+/-)	V <sub>O</sub>	370		1600	mV	7
Receiver Data Rise and Fall Times	T <sub>rf</sub>			400	ps	

**Notes:**

- Over temperature and Beginning of Life. For end of life, see the Avago document entitled "Strained Multi Quantum Well (SMQW) Laser Diode (1300nm 9 well), Publication Number: 5988-5952EN.
- MSA filter is required on host board 10 Hz to 1 MHz. See Figure 1 (Page 2)
- Satisfied after 500 nanoseconds. Within 500 nanoseconds, maximum of current of 2000 mA and energy of 700 nanojoules
- LVTTL, External 4.7 - 10 KΩ Pull-Up Resistor required for TX\_FAULT and MOD-DEF 1 and 2.
- LVTTL, Internal 4.7 - 10 KΩ Pull-Up Resistor included for TX\_Disable
- Internally ac coupled and terminated (100 Ohm differential)
- Internally ac coupled and load termination located at the user SERDES



**Table 6 - Transmitter Optical Characteristics**

Parameter	Symbol	Minimum	Typical	Maximum	Unit	Notes
Output Optical Power (Average)	P <sub>out</sub>	-9.5		-3	dBm	SMFNote 10.
	P <sub>out</sub>	-9.5		-3	dBm	62.5/125 μmNA = 0.2Note 10.
	P <sub>out</sub>	-9.5		-3	dBm	62.5/125 μmNA = 0.275
Optical Extinction Ratio	EXR	9			dB	IEEE 802.3Z
Center Wavelength	λ <sub>C</sub>	1270		1355	nm	
Spectral Width - RMS	σ				nm	Fig 3
Optical Rise/Fall Time	T <sub>rise/fall</sub>			260	ps	20% - 80%IEEE 802.3Z
RIN <sub>12</sub> (OMA), maximum	RIN			-120	dB/Hz	IEEE 802.3Z
				80	ps	IEEE 802.3Z
Contributed Total Jitter	TJ			0.28	UI	IEEE 802.3Z
				227	ps	IEEE 802.3Z
Eye mask margin		10			%	IEEE 802.3Z

**Table 7 - Receiver Optical Characteristics**

Parameter	Symbol	Minimum	Typical	Maximum	Unit	Notes
Optical Power	P <sub>IN</sub>			-3	dBm	IEEE 802.3Z
Receiver Sensitivity	P <sub>REC</sub>			-20	dBm	At BER of 10 <sup>-12</sup>
Stressed Receiver Sensitivity				-14.4	dBm	IEEE 802.3ZNotes 8 and 9.
Receiver Electrical 3 dBUpper Cutoff Frequency				1500	MHz	IEEE 802.3Z
Operating Center Wavelength	λ <sub>C</sub>	1270		1355	nm	
Contributed Total Jitter	TJ			0.332	UI	
Return Loss (minimum)		12			dB	IEEE 802.3Z
Loss of Signal - Deasserted (Average)	P <sub>D</sub>	-30			dB	
Loss of Signal - Asserted (Average)	P <sub>A</sub>			-20	dB	
Loss of Signal - Hysteresis	P <sub>D</sub> - P <sub>A</sub>	0.5			dB	

**Notes:**

8. Special pattern - simulates dispersion of fiber.

9. Compliant signal applied.

10. Optical power range based on discussions in Ethernet Committee to ensure required link budget for 10km link. When used with an offset launch patch cord.

**Table 8 - Transceiver Timing Characteristics**

Parameter	Symbol	Minimum	Typical	Maximum	Unit	Notes
Tx Disable Assert Time	t_off			10	μs	11 IEEE 802.3
Tx Disable Negate Time	t_on			1	mS	12IEEE 802.3
Time to initialize, including reset ofTx-Fault	t_init			300	mS	13
Tx Fault Assert Time	t_fault			100	μs	14
Tx Disable to Reset	t_reset	10			μs	15
LOS Assert Time	t_loss_on			100	μs	16
LOS Deassert Time	t_loss_off			100	μs	17
Serial ID Clock Rate	f_serial_ clock			100	KHz	

**Notes:**

- 11. Time from rising edge of Tx Disable to when the optical output falls below 10% of nominal.
- 12. Time from falling edge of Tx Disable to when the modulated optical output rises above 90% of nominal.
- 13. From power on or negation of Tx Fault using Tx Disable.
- 14. Time from fault to Tx fault on.
- 15. Time Tx Disable must be held high to reset Tx\_fault.
- 16. Time from LOS state to Rx LOS assert.
- 17. Time from non-LOS state to RX LOS deassert.

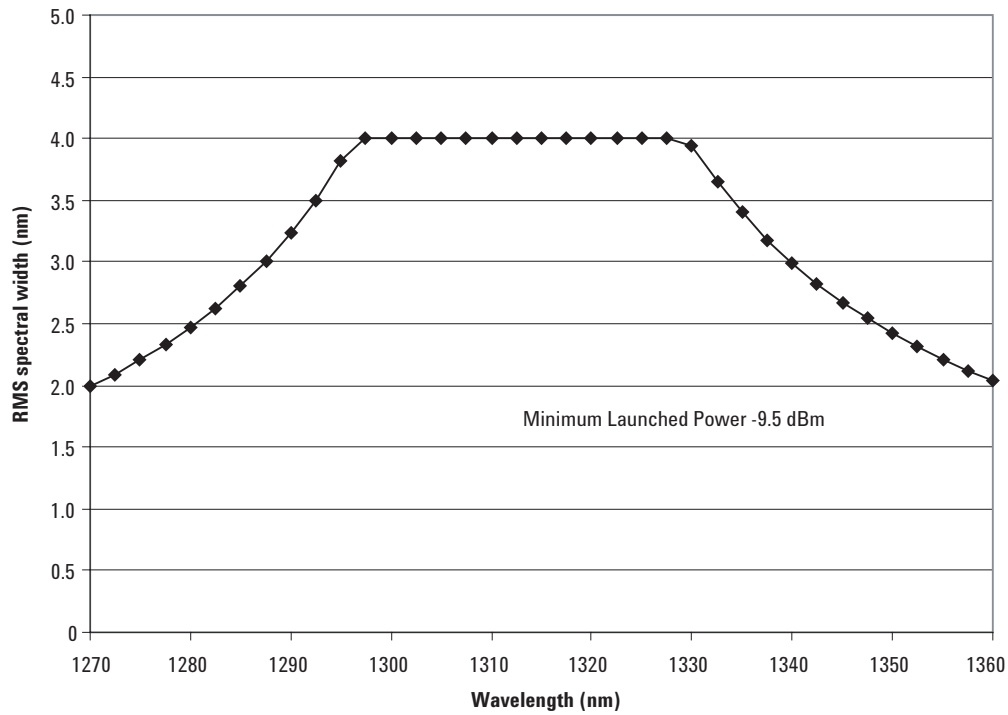

**Figure 3. Tradeoff curves from FC-PI Rev 13**

**Table 9 - EEPROM Serial ID Memory Contents**

Addr	Hex	ASCII	Addr	Hex	ASCII	Addr	Hex	ASCII	Addr	Hex	ASCII
0	03		40	48	H	68	Serial #		96	Note 1	20
1	04		41	46	F	69	Serial #		97	Note 1	20
2	07		42	43	C	70	Serial #		98	Note 1	20
3	00		43	54	T	71	Serial #		99	Note 1	20
4	00		44	2D	-	72	Serial #		100	Note 1	20
5	00		45	35	5	73	Serial #		101	Note 1	20
6	02		46	37	7	74	Serial #		102	Note 1	20
7	00		47	31	1	75	Serial #		103	Note 1	20
8	00		48	30	0	76	Serial #		104	Note 1	20
9	00		49	4C	L	77	20		105	Note 1	20
10	00		50	20		78	20		106	Note 1	20
11	01		51	20		79	20		107	Note 1	20
12	0C		52	20		80	20		108	Note 1	20
13	00		53	20		81	20		109	Note 1	20
14	0A		54	20		82	20		110	Note 1	20
15	64		55	20		83	20		111	Note 1	20
16	37		56	20		84	Datecode		112	Note 1	20
17	37		57	20		85	Datecode		113	Note 1	20
18	00		58	20		86	Datecode		114	Note 1	20
19	00		59	20		87	Datecode		115	Note 1	20
20	41	A	60	00		88	Datecode		116	Note 1	20
21	56	V	61	00		89	Datecode		117	Note 1	20
22	41	A	62	00		90	Datecode		118	Note 1	20
23	47	G	63	Checksum		91	Datecode		119	Note 1	20
24	4F	O	64	00		92	00		120	Note 1	20
25	20		65	1A		93	00		121	Note 1	20
26	20		66	00		94	00		122	Note 1	20
27	20		67	00		95	Checksum		123	Note 1	20
28	20								124	Note 1	20
29	20								125	Note 1	20
30	20								126	Note 1	20
31	20								127	Note 1	20
32	20										
33	20										
34	20										
35	20										
36	00										
37	00										
38	30										
39	D3										

**Note**

1. These fields are reserved for the future use of Avago Technologies.

For product information and a complete list of distributors, please go to our web site: [www.avagotech.com](http://www.avagotech.com)

Avago, Avago Technologies, and the A logo are trademarks of Avago Technologies, Limited in the United States and other countries.  
Data subject to change. Copyright © 2007 Avago Technologies Limited. All rights reserved. Obsoletes 5988-8141EN  
AV02-0631EN - July 27, 2007

