

LPC IO with 8042 KBC, Reset Generation, HWM and Multiple Serial Ports

PRODUCT FEATURES

Data Brief

- **General Features**
 - 3.3 Volt Operation (SIO Block is 5 Volt Tolerant)
 - Low Pin Count Bus (LPC) Interface
 - Programmable Wake-up Event (PME) Interface
 - PC99, PC2001 Compliant
 - ACPI 2.0 Compliant
 - Serial IRQ Interface Compatible with Serialized IRQ Support for PCI Systems
 - ISA Plug-and-Play Compatible Register Set
 - Four Address Options for Power On Configuration Port
 - System Management Interrupt (SMI)
 - 40 General Purpose I/O pins
 - 6 GPIO with VID compatible inputs
 - Support for power button on PS/2 Keyboard
 - Security Key Register (32 byte) for Device Authentication
- **Watchdog Timer**
- **Resume and Main Power Good Generator**
- **Programmable Clock Output to 16 HZ.**
- **2.88MB Super I/O Floppy Disk Controller**
 - Licensed CMOS 765B Floppy Disk Controller
 - Supports Two Floppy Drives
 - Configurable Open Drain/Push-Pull
 - Supports Vertical Recording Format
 - 16-Byte Data FIFO
 - 100% IBM® Compatibility
 - Detects All Overrun and Underrun Conditions
 - Sophisticated Power Control Circuitry (PCC) Including Multiple Powerdown Modes for Reduced Power Consumption
 - DMA Enable Logic
 - Data Rate and Drive Control Registers
 - 480 Address, Up to Eight IRQ and Four DMA Options
 - Support FDD Interface on Parallel Port Pins
- **Enhanced Digital Data Separator**
 - 2 Mbps, 1 Mbps, 500 Kbps, 300 Kbps, 250 Kbp Data Rates
 - Programmable Precompensation Modes
- **Keyboard Controller**
 - 8042 Software Compatible
 - 8 Bit Microcomputer
 - 2k Bytes of Program ROM
 - 256 Bytes of Data RAM
 - Four Open Drain Outputs Dedicated for Keyboard/Mouse Interface
 - Asynchronous Access to Two Data Registers and One Status Register
 - Supports Interrupt and Polling Access
 - 8 Bit Counter Timer
 - Port 92 Support
 - Fast Gate A20 and KRESET Outputs
 - Phoenix Keyboard BIOS ROM
- **Multiple Serial Ports**
 - SCH3112 - 2 Full Function Serial Ports
 - SCH3114 - 4 Full Function Serial Ports
 - SCH3116 - 4 Full Function and 2 Four-Pin Serial Ports
 - High Speed NS16C550A Compatible UARTs with Send/Receive 16-Byte FIFOs
 - Supports 230k, 460k, 921k and 1.5M Baud
 - Programmable Baud Rate Generator
 - Modem Control Circuitry
 - 480 Address and 15 IRQ Options
 - Support IRQ Sharing among serial ports
 - RS485 Auto Direction Control Mode
- **Infrared Port**
 - Multiprotocol Infrared Interface
 - IrDA 1.0 Compliant
 - SHARP ASK IR
 - 480 Addresses, Up to 15 IRQ
- **Multi-Mode™ Parallel Port with ChiProtect™**
 - Standard Mode IBM PC/XT®, PC/AT®, and PS/2™ Compatible Bi-directional Parallel Port
 - Enhanced Parallel Port (EPP) Compatible - EPP 1.7 and EPP 1.9 (IEEE 1284 Compliant)
 - IEEE 1284 Compliant Enhanced Capabilities Port (ECP)
 - ChiProtect Circuitry for Protection
 - 960 Address, Up to 15 IRQ and Four DMA Options
- **Hardware Monitor**
 - Monitor Power supplies (+2.5V, +5V, +12V, Vccp (processor voltage), VCC, Vbat and Vtr.
 - Remote Thermal Diode Sensing for Two External Temperature Measurements accurate to 1.5°C
 - Internal Ambient Temperature Measurement
 - Limit Comparison of all Monitored Values
 - Programmable Automatic FAN control based on temperature
 - nHWM_INT Pin for out-of-limit Temperature or Voltage Indication
 - Thermtrip signal for over temperature indication
- **IDE Reset Output and 3 PCI Reset Buffers with Software Control Capability (SCH3112 and SCH3114 Only)**
- **Power Button Control and AC Power Failure Recovery (SCH3112 and SCH3114 Only)**
- **Temperature Range Available**
 - Industrial (+85°C to -40°C)
 - Commercial (+70°C to 0°C)
- **128 Pin VTQFP Lead-free RoHS Compliant Package**

ORDER NUMBERS:

SCH3112i-NU FOR 128 PIN, VTQFP PACKAGE (LEAD-FREE, ROHS COMPLAINT - INDUSTRIAL TEMPERATURE RANGE)
SCH3114i-NU FOR 128 PIN, VTQFP PACKAGE (LEAD-FREE, ROHS COMPLAINT - INDUSTRIAL TEMPERATURE RANGE)
SCH3116i-NU FOR 128 PIN, VTQFP PACKAGE (LEAD-FREE, ROHS COMPLAINT - INDUSTRIAL TEMPERATURE RANGE)
SCH3112-NU FOR 128 PIN, VTQFP PACKAGE (LEAD-FREE, ROHS COMPLAINT - COMMERCIAL TEMPERATURE RANGE)
SCH3114-NU FOR 128 PIN, VTQFP PACKAGE (LEAD-FREE, ROHS COMPLAINT - COMMERCIAL TEMPERATURE RANGE)
SCH3116-NU FOR 128 PIN, VTQFP PACKAGE (LEAD-FREE, ROHS COMPLAINT - COMMERCIAL TEMPERATURE RANGE)



80 ARKAY DRIVE, HAUPPAUGE, NY 11788 (631) 435-6000, FAX (631) 273-3123

Copyright © 2007 SMSC or its subsidiaries. All rights reserved.

Circuit diagrams and other information relating to SMSC products are included as a means of illustrating typical applications. Consequently, complete information sufficient for construction purposes is not necessarily given. Although the information has been checked and is believed to be accurate, no responsibility is assumed for inaccuracies. SMSC reserves the right to make changes to specifications and product descriptions at any time without notice. Contact your local SMSC sales office to obtain the latest specifications before placing your product order. The provision of this information does not convey to the purchaser of the described semiconductor devices any licenses under any patent rights or other intellectual property rights of SMSC or others. All sales are expressly conditional on your agreement to the terms and conditions of the most recently dated version of SMSC's standard Terms of Sale Agreement dated before the date of your order (the "Terms of Sale Agreement"). The product may contain design defects or errors known as anomalies which may cause the product's functions to deviate from published specifications. Anomaly sheets are available upon request. SMSC products are not designed, intended, authorized or warranted for use in any life support or other application where product failure could cause or contribute to personal injury or severe property damage. Any and all such uses without prior written approval of an Officer of SMSC and further testing and/or modification will be fully at the risk of the customer. Copies of this document or other SMSC literature, as well as the Terms of Sale Agreement, may be obtained by visiting SMSC's website at <http://www.smisc.com>. SMSC is a registered trademark of Standard Microsystems Corporation ("SMSC"). Product names and company names are the trademarks of their respective holders.

SMSC DISCLAIMS AND EXCLUDES ANY AND ALL WARRANTIES, INCLUDING WITHOUT LIMITATION ANY AND ALL IMPLIED WARRANTIES OF MERCHANTABILITY, FITNESS FOR A PARTICULAR PURPOSE, TITLE, AND AGAINST INFRINGEMENT AND THE LIKE, AND ANY AND ALL WARRANTIES ARISING FROM ANY COURSE OF DEALING OR USAGE OF TRADE. IN NO EVENT SHALL SMSC BE LIABLE FOR ANY DIRECT, INCIDENTAL, INDIRECT, SPECIAL, PUNITIVE, OR CONSEQUENTIAL DAMAGES; OR FOR LOST DATA, PROFITS, SAVINGS OR REVENUES OF ANY KIND; REGARDLESS OF THE FORM OF ACTION, WHETHER BASED ON CONTRACT; TORT; NEGLIGENCE OF SMSC OR OTHERS; STRICT LIABILITY; BREACH OF WARRANTY; OR OTHERWISE; WHETHER OR NOT ANY REMEDY OF BUYER IS HELD TO HAVE FAILED OF ITS ESSENTIAL PURPOSE, AND WHETHER OR NOT SMSC HAS BEEN ADVISED OF THE POSSIBILITY OF SUCH DAMAGES.

General Description

The SCH3112/SCH3114/SCH3116 Product Family is a 3.3V (Super I/O Block is 5V tolerant) PC99/PC2001 compliant Super I/O controller with an LPC interface. The SCH3112/SCH3114/SCH3116 Product Family also includes Hardware Monitoring capabilities, enhanced Security features, Power Control logic and Motherboard Glue logic.

The SCH3112/SCH3114/SCH3116 Product Family's hardware monitoring capability includes temperature, voltage and fan speed monitoring. It has the ability to alert the system of out-of-limit conditions and automatically control the speeds of multiple fans. There are four analog inputs for monitoring external voltages of +5V, +2.5V, +12V and V_{ccp} (core processor voltage), as well as internal monitoring of the SIO's VCC, VTR, and V_{bat} power supplies. The SCH3112/SCH3114/SCH3116 Product Family includes support for monitoring two external temperatures via thermal diode inputs and an internal sensor for measuring ambient temperature. The nHWM_INT pin is implemented to indicate out-of-limit temperature, voltage, and FANTACH conditions. The hardware monitoring block of the SCH3112/SCH3114/SCH3116 Product Family is accessible via the LPC bus. The same interrupt event reported on the nHWM_INT pin also creates PME wakeup events. A separate THERMTRIP output is available, which generates a pulse output on a programmed over temperature condition. This can be used to generate an reset or shutdown indicator to the system.

The hardware monitoring capability also has programmable automatic FAN control. Three fan tachometer inputs and three pulse width modulator (PWM) outputs are available.

The Motherboard Glue logic includes various power management and system logic including generation of nRSMRST, a programmable Clock output, and reset generation. The reset generation includes a watchdog timer which can be used to generate a reset pulse. The width of this pulse is selectable via an external strapping option.

The SCH3112/SCH3114/SCH3116 Product Family incorporates complete legacy Super I/O functionality including an 8042 based keyboard and mouse controller, an IEEE 1284, EPP, and ECP compatible parallel port, multiple serial ports, one IrDA 1.0 infrared ports, and a floppy disk controller with SMSC's true CMOS 765B core and enhanced digital data separator, The true CMOS 765B core provides 100% compatibility with IBM PC/XT and PC/AT architectures and is software and register compatible with SMSC's proprietary 82077AA core. System related functionality, which offers flexibility to the system designer, General Purpose I/O control functions, and control of two LED's.

The serial ports are fully functional NS16550 compatible UARTs that support data rates up to 1.5 Mbps. There are four, 8 pin Serial Ports and two, 4pin Serial Ports. The reduced pin serial ports have selectable input and output controls. The Serial Ports contain programmable direction control, which will automatically Drive nRTS when the Output Buffer is loaded, then Drive nRTS when the Output Buffer is Empty.

The SCH3112/SCH3114/SCH3116 Product Family is ACPI 1.0/2.0 compatible and therefore supports multiple low power-down modes. It incorporates sophisticated power control circuitry (PCC), which includes support for keyboard.

The SCH3112/SCH3114/SCH3116 Product Family supports the ISA Plug-and-Play Standard register set (Version 1.0a). The I/O Address, DMA Channel and hardware IRQ of each logical device in the SCH3112/SCH3114/SCH3116 Product Family may be reprogrammed through the internal configuration registers. There are up to 480 (960 - Parallel Port) I/O address location options, a Serialized IRQ interface, and Three DMA channels.

Table 1 Device Specific Summary

FUNCTION	SCH3112	SCH3114	SCH3116
LPC Bus Interface	YES	YES	YES
Legacy functional Blocks (1.)	YES	YES	YES
Floppy on Parallel Port Option	YES	YES	YES
Reset Generator	YES	YES	YES
Serial Ports	2	4	6 (2.)
Programmable Clock Output	YES	YES	YES
IDE / PCI Reset Outputs	YES	YES	NO
Power Button / AC Fail Support	YES	YES	NO
GPIOs	40	40	40
GPIO with VID Compatible Inputs	6	6	6
Dedicated GPIOs	16	0	0
Hardware Monitor	YES	YES	YES

1. Legacy Blocks include floppy disk, parallel port, watchdog timer and keyboard controller

2. 2 of the 6 serial ports have 4 pin interfaces

Block Diagram

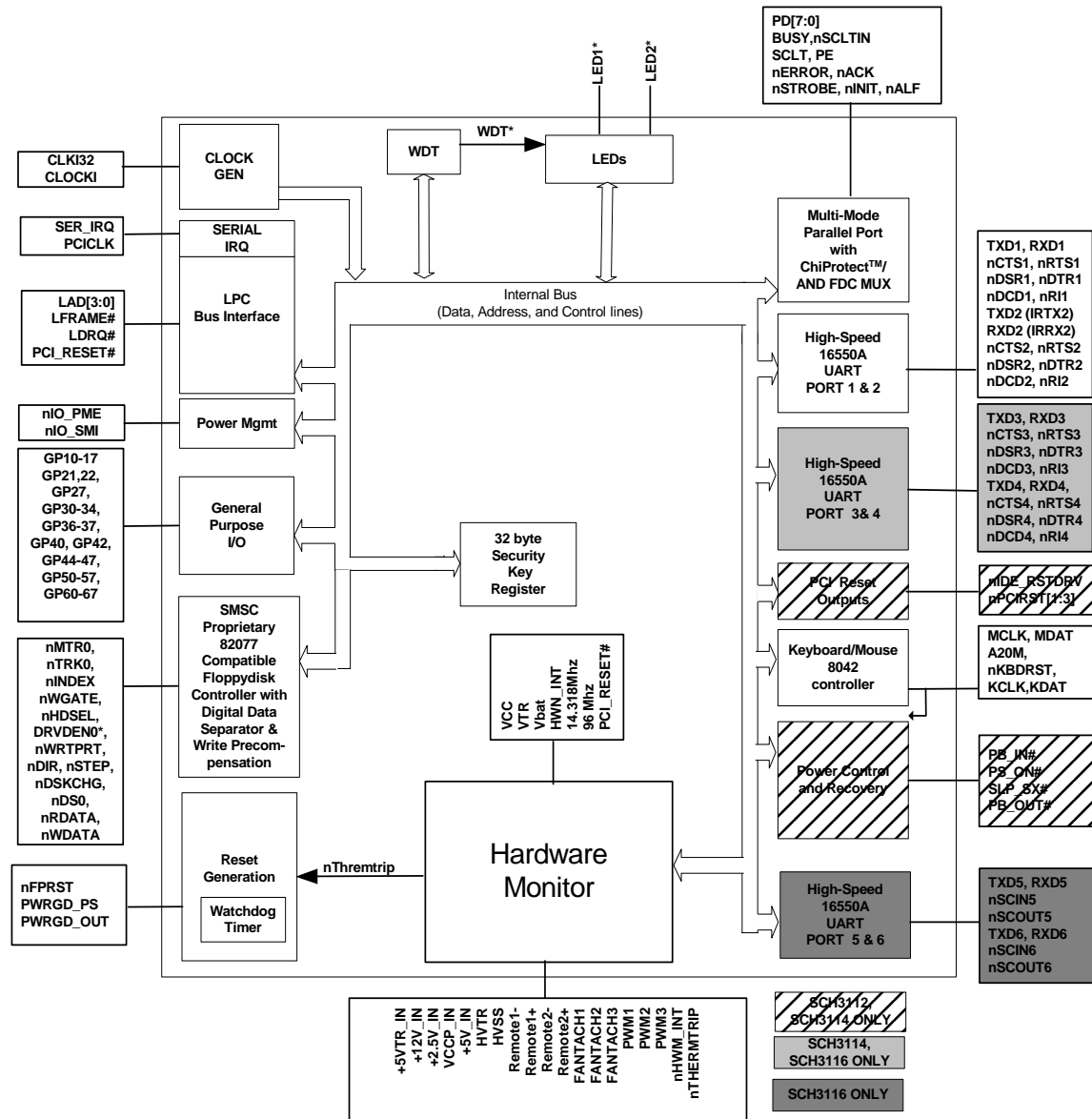

Figure 1 SCH311X Block Diagram

Package Outline

Revision 1.1 (06-05-07)

PRODUCT PREVIEW

SMSC SCH311X

LPC IO with 8042 KBC, Reset Generation, HWM and Multiple Serial Ports

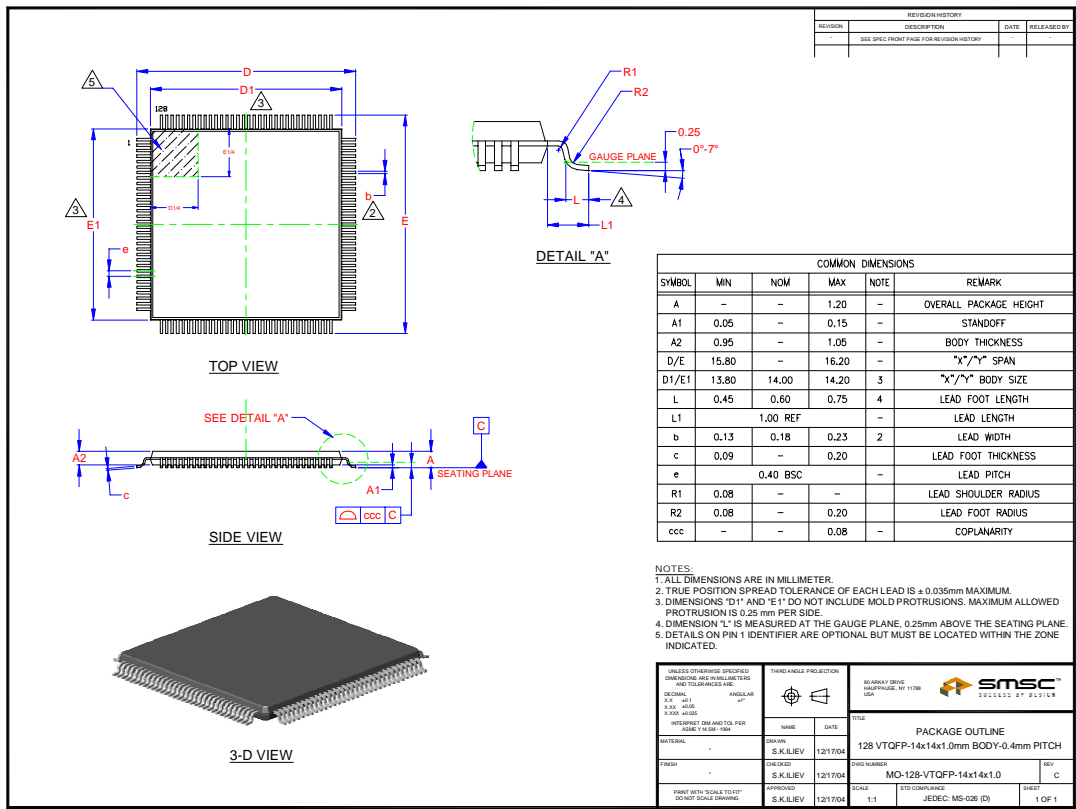

Figure 2 128 Pin VTQFP Package Outline; 14x14x1.0 Body, 2mm Footprint