

PRODUCT NO.
58554-050HA/050HALF

- NOTES:
- 8mm MIN. CARD EJECT.
 - EJECT TRAVEL: 9.5mm
 - MATERIAL
 - HEADER ASS'Y
PLASTIC : HOUSING ...LCP UL94V-O BLACK
PIN : COPPER ALLOY
PCB : FR4
 - EJECT MECHANISM ASS'Y
PLASTIC : GUIDE: POLYPHTHARAMID UL94V-O BLACK
: BUTTON: POLYPHTHARAMID UL94V-O BLACK
PLATE : STAINLESS
EMI CONTACT: PHOSPHOR BRONZE
 - RECEPTACLE
PLASTIC : LCP 94V-O, NATURAL.
PIN: BeCu
 - FINISH (PIN)
UNDER PLATING : 0.5 um MIN. Ni
CONTACT AREA : 0.1 um MIN. GOLD OVER 0.5 um MIN. Pd-Ni
SOLDER TAIL (TIN LEAD OPTION): 2.5 um MIN. Sn-Pb
SOLDER TAIL (LEAD FREE OPTION): 2.5 um MIN. PURE TIN
- ⑤ PUSH ROD LOCATION AND P.C.B. SIDE ARE AS APPEARS INSTALLED.
- | | | |
|----------|---------|------------------|
| 4.25±0.1 | 3.5±0.1 | 5.0±0.1 |
| OTHERS | 36,67 | 1,17,34,35,51,68 |
- RECOMMENDED M2 SCREW LENGTH (L) : 10.5mm
 - IF LEAD FREE P.N. THE HOUSING WILL WITHSTAND EXPOSURE TO 260°C PEAK TEMPERATURE FOR 10 SECONDS IN A WAVE SOLDER APPLICATION WITH A 1.00MM MINIMUM THICK CIRCUIT BOARD.
 - IF LEAD FREE P/N. THE PRODUCT MEETS EUROPEAN UNION DIRECTIVES AND OTHER COUNTRY REGULATIONS AS DESCRIBED IN GS-22-008
 - LEAD FREE P/N PACKAGING MEETS GS-14-920 SPECIFICATION

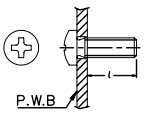
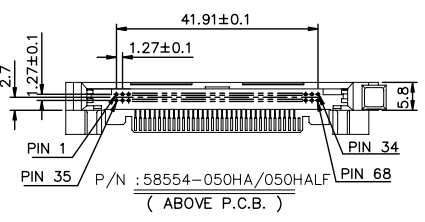
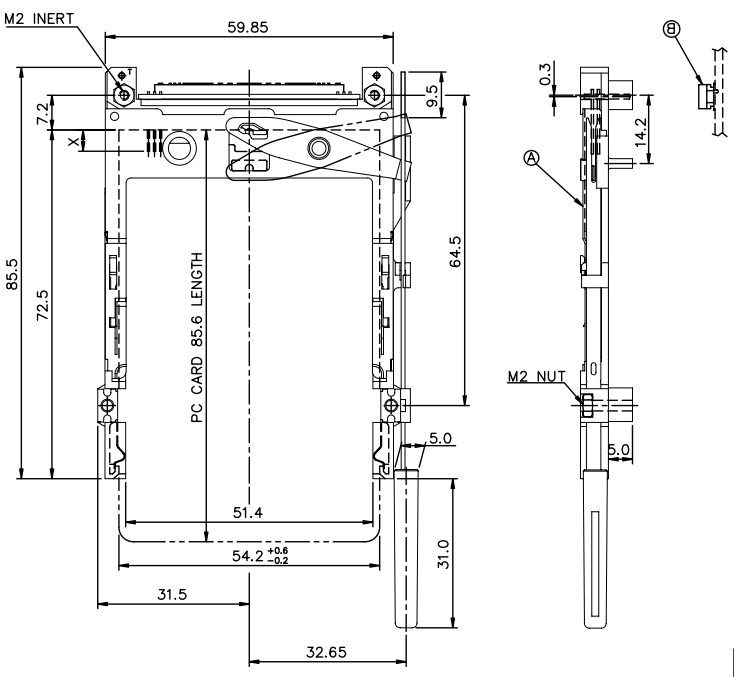

ORDERING INFORMATION

NAME	PART NO.		Q'TY
Ⓐ EJECT HEADER ASS'Y	58554-050HA	58554-050HALF	1
Ⓑ MATING RECEPTACLE	91931-31169	91931-31169LF	1

mat'l code		tolerance unless otherwise specified		CUSTOMER COPY		 www.fciconnect.com	
rev.	ecn no.	dr	date	linear	±0.30	projection	title
A	T03-0394	WL	09/17/03				PCMCIA TRANSITION BOARD
B	T04-0010	WL	01/06/04				3.3V EJECTOR TYPE 1/2/3
C	N05-0047	WB	02/21/08	angles	± 2°		
		dr	WENDY CHEN	01/17/02		unit	product family
		engr	MINERVA WANG	01/17/02		mm/inch	PCMCIA
		chr	MINERVA WANG	01/17/02		size	code
		appd	JENN TSAO	01/17/02		scale	58554
sheet	revision	C	A				
index	sheet	1	2				sheet 1 of 2

PDM: Rev:C STATUS Released Printed: Oct 12, 2010

All rights strictly reserved. Reproduction or issue to third parties in any form or by any means, electronic or mechanical, including photocopying, recording, or by any information storage and retrieval system, is prohibited without written authority from the proprietor. Copyright © BERG ELECTRONICS BV.

