

## LQ050W1LA0A LCD Module

### Product Specification

June 2008

WSVGA LCD Module featuring extremely high resolution, touch panel, LVDS interface, and a built-in, PWM-compatible driver for its LED backlight. Module has 350 nits brightness with 450:1 contrast.

**SHARP**<sup>®</sup>

APREPARED BY :     DATE	<b>SHARP</b>	SPEC No. LD-20132B
APPROVED BY :     DATE		FILE No.
		ISSUE : Mar. 06. 2008
	MOBILE LIQUID CRYSTAL DISPLAY GROUP SHARP CORPORATION	PAGE : 23 pages
	<b>SPECIFICATION</b>	APPLICABLE GROUP MOBILE LIQUID CRYSTAL DISPLAY GROUP

Revised : Jun. 19. 2008

DEVICE SPECIFICATION FOR  
**TFT-LCD Module**  
 MODEL No.  
**LQ050W1LA0A**

CUSTOMER'S APPROVAL

DATE \_\_\_\_\_

BY \_\_\_\_\_

PRESENTED

BY *K. Shiono*

K. SHIONO  
 Department General Manager  
 Engineering Dept.  
 MOBILE LCD DIVISION III  
 MOBILE LIQUID CRYSTAL DISPLAY GROUP  
 SHARP CORPORATION



These specification sheets are the proprietary product of SHARP CORPORATION("SHARP) and include materials protected under copyright of SHARP. Do not reproduce or cause any third party to reproduce them in any form or by any means, electronic or mechanical, for any purpose, in whole or in part, without the express written permission of SHARP.

In case of using the device for applications such as control and safety equipment for transportation(aircraft, trains, automobiles, etc. ), rescue and security equipment and various safety related equipment which require higher reliability and safety, take into consideration that appropriate measures such as fail-safe functions and redundant system design should be taken.

Do not use the device for equipment that requires an extreme level of reliability, such as aerospace applications, telecommunication equipment(trunk lines), nuclear power control equipment and medical or other equipment for life support.

SHARP assumes no responsibility for any damage resulting from the use of the device, which does not comply with the instructions, and the precautions specified in these specification sheets.

Confirm "13. Handling Precautions " item when you use the device.

Contact and consult with a SHARP sales representative for any questions about this device.

## Table of contents

1. Application .....	3
2. Overview.....	3
3. Mechanical Specifications .....	3
4. Input Terminals.....	4
4 - 1. Symbol .....	4
4 - 2. Function.....	4
4 - 3. LVDS interface block diagram.....	6
5. Absolute Maximum Ratings .....	7
6. Electrical Characteristics .....	7
6 - 1. TFT-LCD panel driving .....	7
6 - 2. Backlight driving.....	9
6 - 3. LVDS input specification.....	11
6 - 3 - 1. AC characteristics .....	11
6 - 3 - 2. LVDS data .....	12
7. Touch panel characteristics.....	12
8. Timing Characteristics of Input Signals.....	12
8 - 1. Timing characteristics .....	12
8 - 2. Input data signals and display position on the screen.....	13
9. Input Signals, Basic Display Colors and Gray Scale of Each Color .....	14
10. Optical Characteristics .....	15
11. Display Quality .....	16
12. Design guidance for touchpanel(T/P) .....	17
12 - 1. Example of housing design .....	17
12 - 2. Mounting on display and housing bezel.....	17
13. Handling Precautions .....	18
14. Packing Form.....	19
15. Storage condition .....	19
16. Reliability Test Items.....	20
17. Label .....	21
18. RoHS Regulations.....	21
Fig. 1 Packing form.....	22
Fig. 2 Outline Dimensions .....	23

### 1. Application

This specification applies to a color TFT-LCD module, LQ050W1LA0A.

### 2. Overview

This module is a color active matrix LCD module incorporating amorphous silicon TFT (Thin Film Transistor). It is composed of a color TFT-LCD panel, driver ICs, a control circuit and power supply circuit, a backlight unit, and a touch panel. Graphics and texts can be displayed on a 1024×3×600 dots panel with 262,144 colors by using LVDS (Low Voltage Differential Signaling) to interface and supplying +3.3V DC supply voltage for TFT-LCD panel driving and supply voltage for backlight.

In this TFT-LCD panel, low reflection / color filters of excellent color performance and backlights of high brightness are incorporated to realize brighter and clearer pictures, making this model optimum for use in multi-media applications.

Optimum viewing direction is 6 o'clock.

Backlight-driving LED controller is built in this module.

### 3. Mechanical Specifications

Parameter	Specifications	Unit
Display size	12.6 (5.0") Diagonal	cm
Active area	109.1 (H)×63.9 (V)	mm
Pixel format	1024 (H)×600 (V)	pixel
	(1 pixel = R+G+B dots)	
Pixel pitch	0.106 (H)×0.106 (V)	mm
Pixel configuration	R,G,B vertical stripe	
Display mode	Normally white	
Surface treatment	Glare and hard-coating (2H)	

Parameter		Min.	Typ.	Max.	Unit
Unit outline dimensions [Note 1]	Width	118.7	119.0	119.3	mm
	Height	76.0	76.3	76.6	mm
	Depth	—	5.4	5.6	mm
Mass		—	67	72	g

[Note 1] Outline dimensions is shown in Fig.2

Excluding Touch Panel FPC.

## 4. Input Terminals

## 4 - 1. Symbol

CN1 (LVDS signals,+3.3V DC power supply,B/L power supply,B/L control signal and TP signal)

Pin No.	Symbol	Pin No.	Symbol
2	TP_X2	1	TP_Y2
4	TP_X1	3	TP_Y1
6	GND	5	GND
8	SHTDB	7	BLVcc
10	BRT	9	BLVcc
12	GND	11	BLVcc
14	CKIN+	13	GND
16	CKIN-	15	GND
18	RxIN2+	17	GND
20	RxIN2-	19	GND
22	RxIN1+	21	GND
24	RxIN1-	23	GND
26	RxIN0+	25	Vcc
28	RxIN0-	27	Vcc
30	GND	29	Vcc

## 4 - 2. Function

Pin No.	Symbol	Function	Remark
Power Supply			
25	Vcc	+3.3V power supply	
27	Vcc	+3.3V power supply	
29	Vcc	+3.3V power supply	
7	BLVcc	+5.0~20V power supply (For Backlight driver)	
9	BLVcc	+5.0~20V power supply (For Backlight driver)	
11	BLVcc	+5.0~20V power supply (For Backlight driver)	
5	GND		
6	GND		
12	GND		
13	GND		
15	GND		
17	GND		
19	GND		
21	GND		
23	GND		
30	GND		

LVDS signal			
14	CK IN+	Receiver signal of LVDS CLK (+)	[Note 1]
16	CK IN-	Receiver signal of LVDS CLK (-)	[Note 1]
18	RxIN2+	Receiver signal of LVDS CH2 (+)	[Note 1]
20	RxIN2-	Receiver signal of LVDS CH2 (-)	[Note 1]
22	RxIN1+	Receiver signal of LVDS CH1 (+)	[Note 1]
24	RxIN1-	Receiver signal of LVDS CH1 (-)	[Note 1]
26	RxIN0+	Receiver signal of LVDS CH0 (+)	[Note 1]
28	RxIN0-	Receiver signal of LVDS CH0 (-)	[Note 1]
B/L control signal			
8	SHTDB	Backlight ON/OFF control signal	
10	BRT	Backlight dimming control signal	
Touch Panel signal			
1	TP_Y2	Touch panel Y Bottom terminal	
2	TP_X2	Touch panel X Left terminal	
3	TP_Y1	Touch panel Y Top terminal	
4	TP_X1	Touch panel X Right terminal	

[Note 1] Relation between RxIN<sub>i</sub>(i=0,1,2) and actual data is shown in following section (4-2)(7-2).

[Note 2] The shielding case is connected with signal GND.

Using connector : (DF30FB-30DS-0.4V (HIROSE))

Corresponding connector : (DF30FB-30DP-0.4V (HIROSE))

(Sharp is not responsible to its product quality, if the user applies a connector not corresponding to the above model.)



4 - 3. LVDS interface block diagram

Using receiver : Single LVDS interface contained in a control IC

Corresponding Transmitter : THC63LVDM63A (THINE) or equivalent

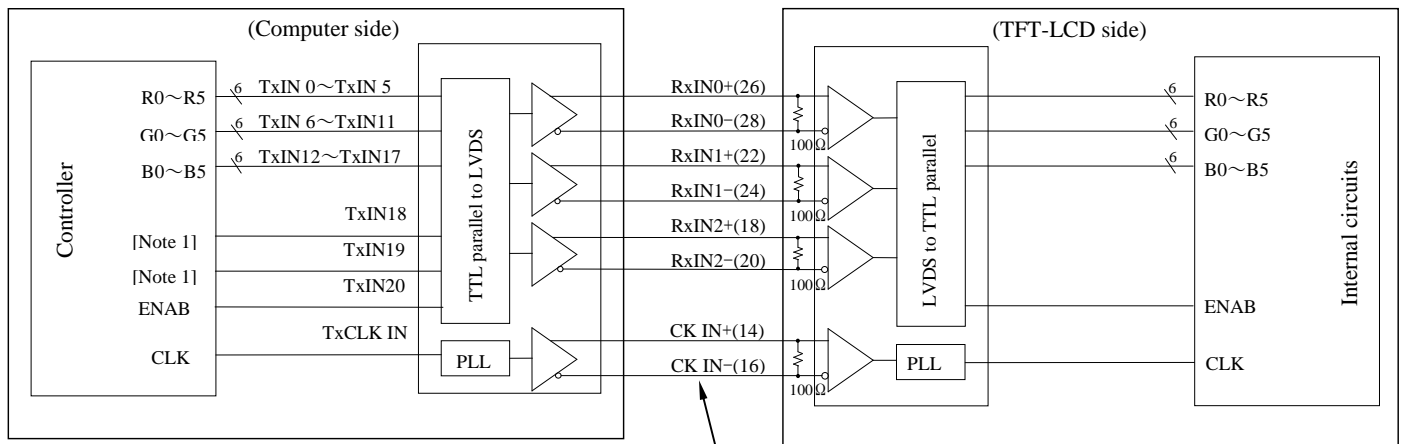

Symbol of CN1 (Pin No.)

[Note 1] Do not use at high-impedance TxIN 18 - 19.

## 5. Absolute Maximum Ratings

Parameter	Symbol	Condition	Ratings		Unit	Remark
			Min.	Max.		
Input voltage	$V_I$	Ta=25°C	-0.3	Vcc+0.3	V	[Note 1]
+3.3V supply voltage	Vcc	Ta=25°C	0	+4.0	V	
LED power supply voltage	BLVcc	Ta=25°C	0	+28.0	V	
LED bright control signal	BRT	Ta=25°C	0	+5.0	V	
LED ON/OFF signal	SHTDB	Ta=25°C	0	+5.0	V	
Storage temperature (ambient)	Tstg	—	-25	+70	°C	[Note 2]
Operating temperature (Panel surface)	Topa	—	0	+60	°C	
Touch panel input voltage	Vtp	Ta=25°C	0	7.0	V	[Note 3]

[Note 1] LVDS signals

[Note 2] Humidity : 95%RH Max. at Ta ≤ +40°C.

Maximum wet-bulb temperature at +39°C or less at Ta > +40°C.

No condensation.

[Note 3] TP\_X1,TP\_Y1,TP\_X2,TP\_Y2 : When touch panel controller is connected.



## 6. Electrical Characteristics

## 6 - 1. TFT-LCD panel driving

Ta = +25°C

Parameter	Symbol	Min.	Typ.	Max.	Unit	Remark	
Supply voltage	Vcc	+3.0	+3.3	+3.6	V	[Note 2]	
Current dissipation	Icc	—	120	160	mA	[Note 3]	
Permissive input ripple voltage	$V_{RP}$	—	—	100	mV <sub>P-P</sub>	Vcc = +3.3V	
Input voltage range	$V_I$	0		2.4	V	LVDS signals	
Differential input threshold voltage	High	$V_{TH}$	—	—	+100	mV	V <sub>CM</sub> = +1.2V [Note 1]
	Low	$V_{TL}$	-100	—	—	mV	
Input current (High)	$I_{OH}$	—	—	±10	μA	$V_I = +2.4V$ Vcc = +3.6V	
Input current (Low)	$I_{OL}$	—	—	±10	μA	$V_I = 0V$ Vcc = 3.6V	
Termination resistor	$R_T$	—	100	—	Ω	Differential input	

[Note 1] V<sub>CM</sub> : Common mode voltage of LVDS driver.

[Note 2] On-off conditions for supply voltage

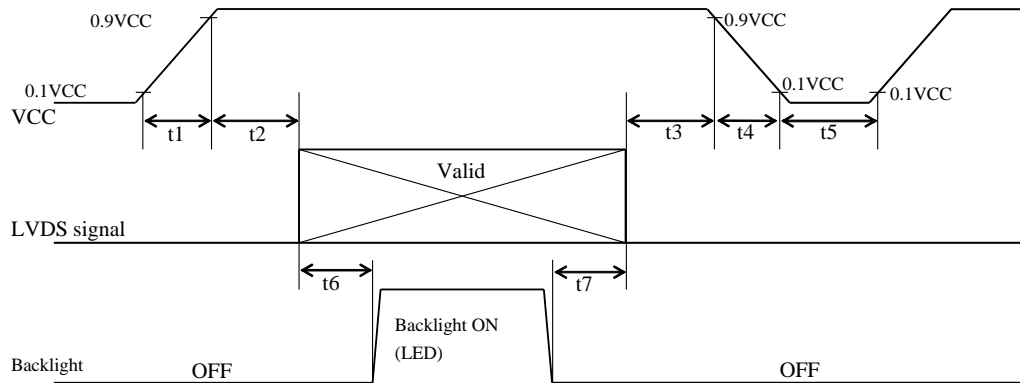

Symbol	Min.	Max.	Remark	
t1	0	10	ms	
t2	0	1	s	
t3	0	1	s	
t4	0	400	ms	
t5	200	—	ms	
t6	180	—	ms	*1
t7	5	—	ms	*1

\*1 : As for the power sequence for backlight, it is recommended to apply above mentioned input timing.

If the backlight is lit on and off at a timing other than shown above, displaying image may get disturbed.

This is due to variation of output signal from timing generator when LVDS signal is changed from on to off or vice versa, but has no harm to the module itself.

[Note] Do not keep the interface signal high-impedance or unusual signal when power is on.

Vcc-dip conditions

- 1)  $2.5\text{ V} \leq V_{cc} < 3.0\text{ V}$   
 $t_d \leq 10\text{ ms}$

Under above condition, the display image should return to an appropriate figure after Vcc voltage recovers.

- 2)  $V_{cc} < 2.5\text{ V}$

Vcc-dip conditions should also follow the On-off conditions for supply voltage

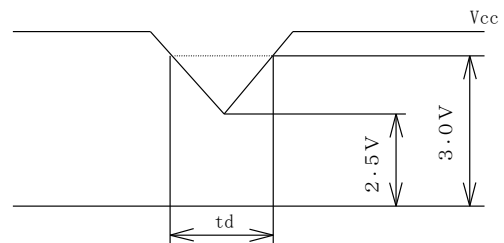

[Note 3] Typical current situation : 16-gray-bar pattern.

$V_{cc}=+3.3\text{V}$

Maximum current situation :  $V_{cc}=+3.6\text{V}$

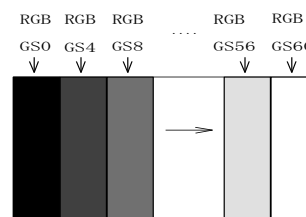

## 6 - 2. Backlight driving



The backlight system is edge-lighting type with LED.

Parameter	Symbol	Min.	Typ.	Max.	Unit	Remark
Supply voltage range	BLVcc	+5.0	+7.4	+20.0	V	[Note 1]
Current dissipation	—	—	125	240	mA	[Note 1,2]
	—	—	—	100	uA	[Note 3]
Permissive input ripple voltage	—	—	—	100	mV <sub>p-p</sub>	[Note 1]
Input signal voltage range	—	0	—	5.0	V	[Note 4]
Input signal High level threshold	—	2.7	—	—	V	[Note 4]
Input signal Low level threshold	—	—	—	0.2	V	[Note 4]
PWM frequency	f <sub>PWM</sub>	200	300	400	Hz	[Note 4,5]
PWM Duty ratio	D <sub>PWM</sub>	1	—	100	%	[Note 4,5]
LED life time	—	10000	15000	—	Hour	[Note 6]

[Note 1] BLVcc

[Note 2] Typ: BLVcc = 7.4V , Max: BLVcc = 5.0V ; D<sub>PWM</sub> =100%

[Note 3] BLVcc = 7.4V,SHTBD="Lo"

[Note 4] BRT,SHTDB

[Note 5] PWM dimming control signal (BRT)

$$f_{\text{PWM}} = 1 / (\text{Ton} + \text{Toff})$$

$$D_{\text{PWM}} = \text{Ton} / (\text{Ton} + \text{Toff})$$

Maximum Luminance: D<sub>PWM</sub> = 100%

In case of using the low frequency, the deterioration of display quality, flicker, etc, may occur.

[Note 6] D<sub>PWM</sub> = 100% Ta=25°C continuous operation

LED life time is defined as the time when Brightness becomes 50 % of the original value under standard condition.

[Note 7] Backlight ON/OFF function

SHTDB	BRT	Backlight
"Lo"	—	OFF
"Hi"	"Lo"	OFF
	"Hi"	ON

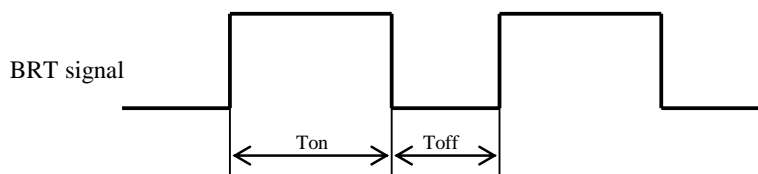

[Note 8] Power supply input sequence

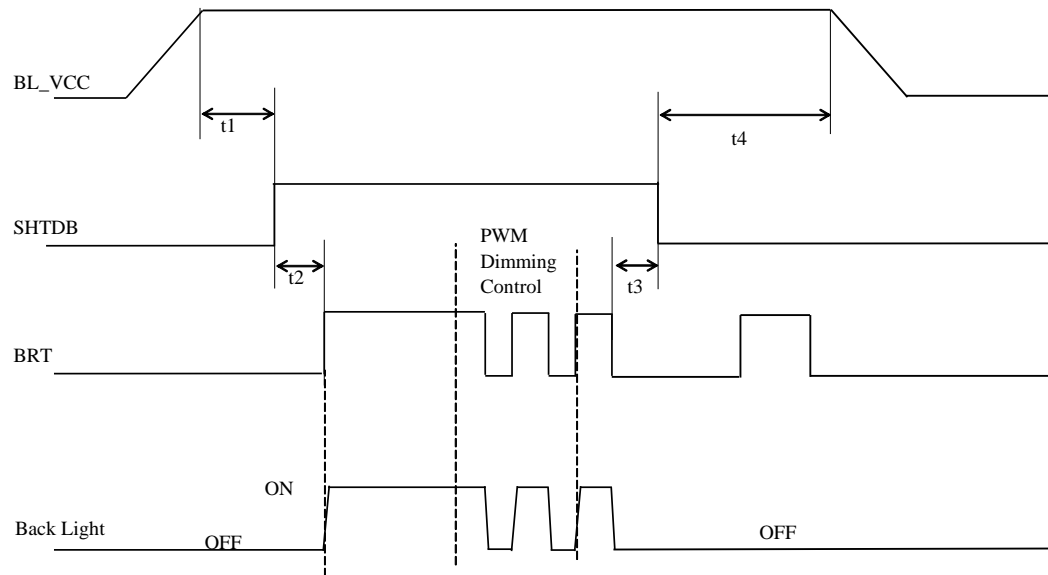

Symbol	Min.	Max.	Unit	Remark
t1	0	—	ms	
t2	0	—	ms	
t3	0	—	ms	
t4	0	—	ms	

## 6 - 3. LVDS input specification

## 6 - 3 - 1. AC characteristics

VCC=+3.0V~+3.6V, Ta=0°C~+60°C

Parameter	Symbol	Min	Typ.	Max.	Unit
Input Data Position 0 (t <sub>RCIP</sub> =20.48ns)	t <sub>RIP1</sub>	-0.25	0.0	+0.25	ns
Input Data Position 1 (t <sub>RCIP</sub> =20.48ns)	t <sub>RIP0</sub>	t <sub>RCIP</sub> /7-0.25	t <sub>RCIP</sub> /7	t <sub>RCIP</sub> /7+0.25	ns
Input Data Position 2 (t <sub>RCIP</sub> =20.48ns)	t <sub>RIP6</sub>	2 t <sub>RCIP</sub> /7-0.25	2 t <sub>RCIP</sub> /7	2 t <sub>RCIP</sub> /7+0.25	ns
Input Data Position 3 (t <sub>RCIP</sub> =20.48ns)	t <sub>RIP5</sub>	3 t <sub>RCIP</sub> /7-0.25	3 t <sub>RCIP</sub> /7	3 t <sub>RCIP</sub> /7+0.25	ns
Input Data Position 4 (t <sub>RCIP</sub> =20.48ns)	t <sub>RIP4</sub>	4 t <sub>RCIP</sub> /7-0.25	4 t <sub>RCIP</sub> /7	4 t <sub>RCIP</sub> /7+0.25	ns
Input Data Position 5 (t <sub>RCIP</sub> =20.48ns)	t <sub>RIP3</sub>	5 t <sub>RCIP</sub> /7-0.25	5 t <sub>RCIP</sub> /7	5 t <sub>RCIP</sub> /7+0.25	ns
Input Data Position 6 (t <sub>RCIP</sub> =20.48ns)	t <sub>RIP2</sub>	6 t <sub>RCIP</sub> /7-0.25	6 t <sub>RCIP</sub> /7	6 t <sub>RCIP</sub> /7+0.25	ns
Phase Lock Loop Set	t <sub>RPLL</sub>	—	—	10	ms
Input Clock Period	t <sub>RCIP</sub>	18.52	20.48	20.83	ns

## LVDS input timing

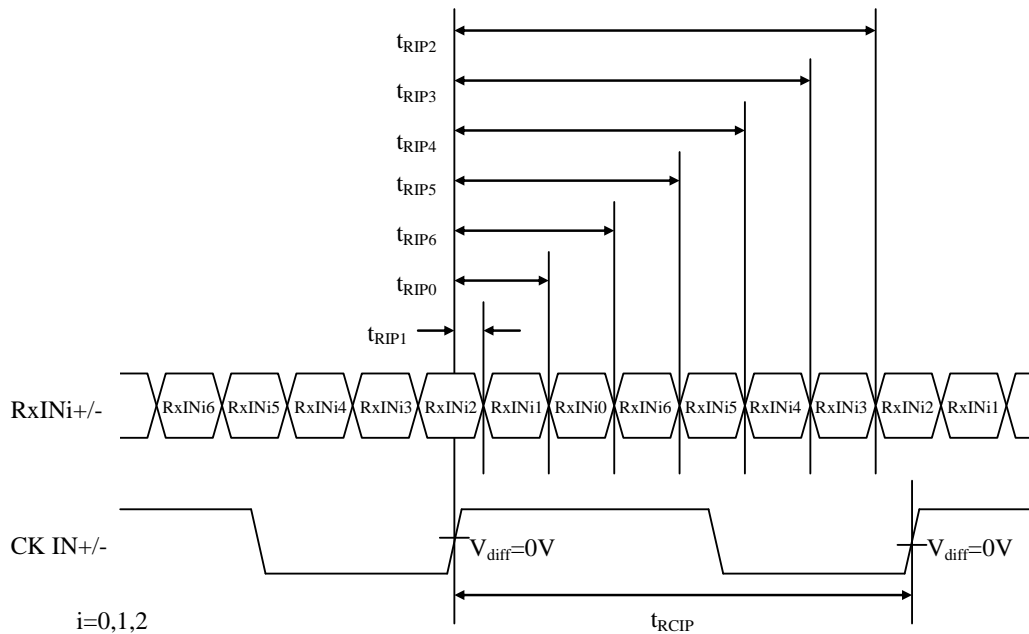

※Note

V<sub>diff</sub>=(RxINi+)-(RxINi-), (CK IN+)-(CK IN-)

## LVDS phase lock loop set

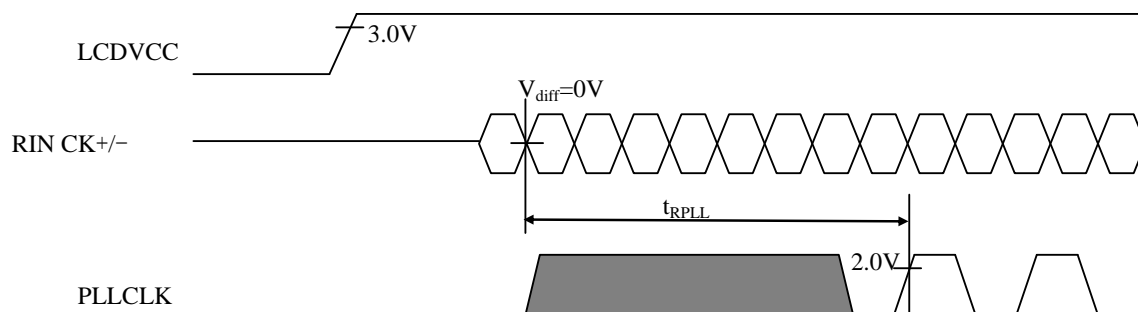

## 6 - 3 - 2. LVDS data

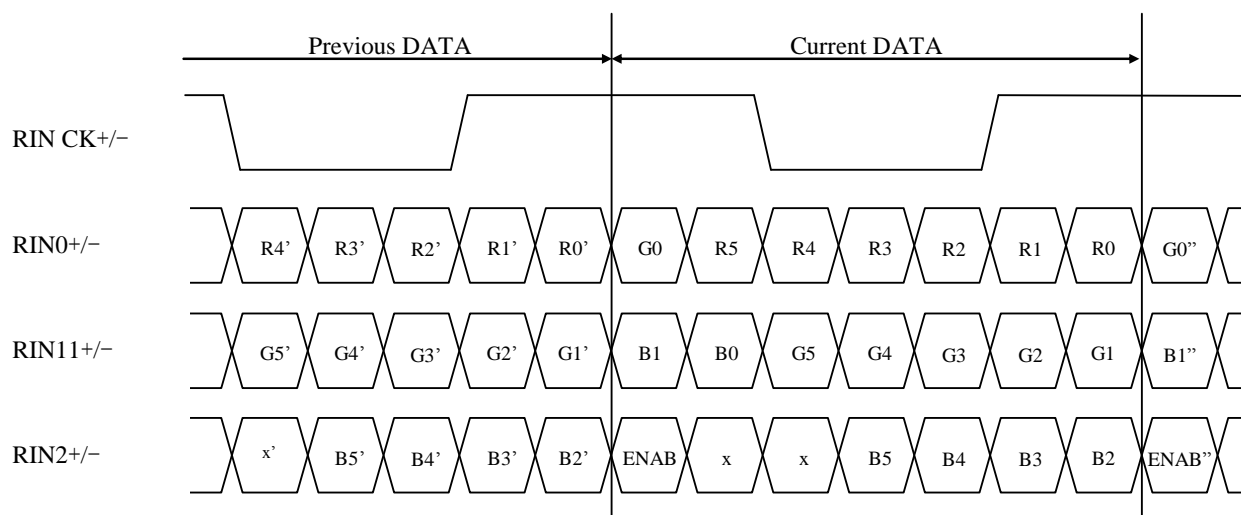

## 7. Touch panel characteristics

1

Parameter	Min.	Typ.	Max.	Unit	Remark
Input voltage	-	5.0	5.5	V	[Note 2]
Resistor between terminals(TP_X1-TP_X2)	250	510	850	$\Omega$	
Resistor between terminals(TP_Y1-TP_Y2)	100	180	300	$\Omega$	
Line linearity(X direction)	-	-	1.5	%	
Line linearity(Y direction)	-	-	1.5	%	
Insuration resistance	20	-	-	M $\Omega$	at DC15V
Minimum tension for detecting	-	-	0.8	N	
Chattering	-	-	10	ms	

[Note 1] Wiring diagram of touch panel

[Note 2] When touch panel controller is connected.

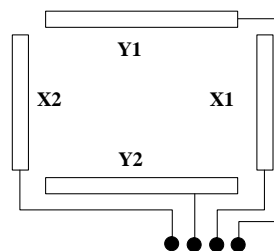

## 8. Timing Characteristics of Input Signals

## 8 - 1. Timing characteristics

 $V_{CC}=+3.0V \sim +3.6V$ ,  $T_a=0^{\circ}C \sim +60^{\circ}C$ 

Parameter		Symbol	Min.	Typ.	Max.	Unit	Remark
Clock	Frequency	1/Tc	48	48.836	54	MHz	[Note 1]
Data enable Signal	Horizontal period	TH	1260	1312	1408	clock	
			24.512	26.865	-	$\mu s$	
	Horizontal period (High)	THd	1024	1024	1024	clock	
	Vertical period	TV	603	621	900	Line	
			16.069	16.683	-	ms	
Vertical period (High)	TVd	600	600	600	line		

[Note 1] In case of using the long vertical period, the deterioration of display quality, flicker, etc., may occur.

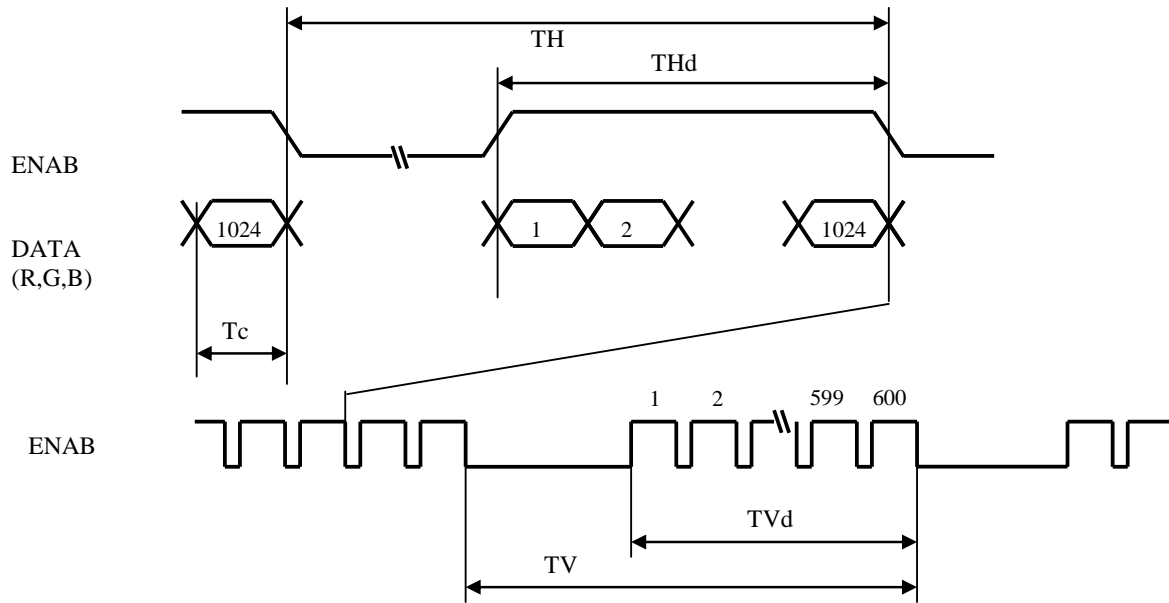

8 - 2. Input data signals and display position on the screen

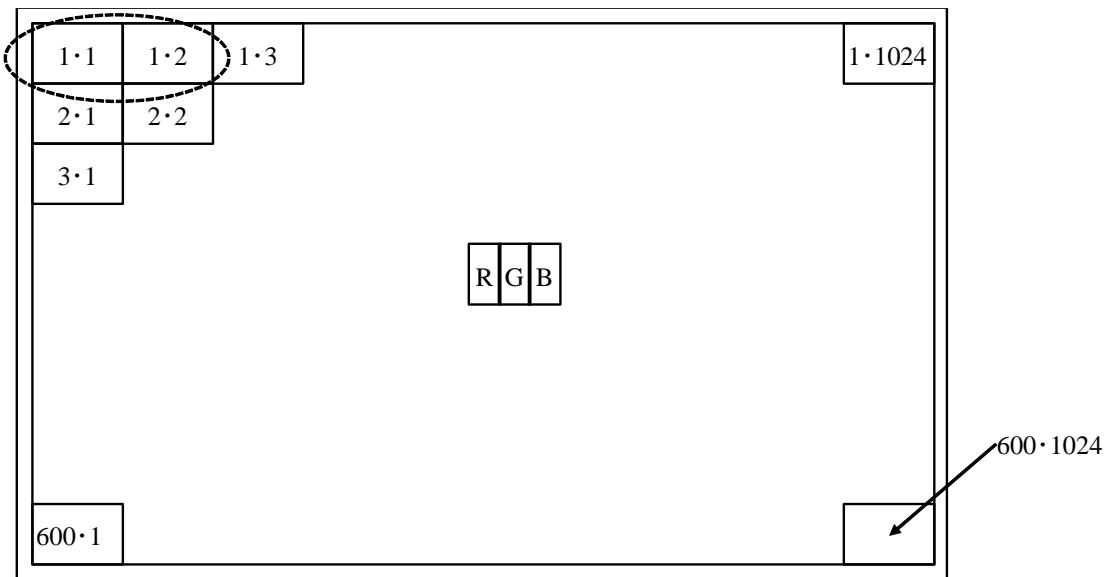

Display position of input data(V · H)



## 9. Input Signals, Basic Display Colors and Gray Scale of Each Color

Colors & Gray scale	Data signal																		
	Gray Scale	R0	R1	R2	R3	R4	R5	G0	G1	G2	G3	G4	G5	B0	B1	B2	B3	B4	B5
Basic Color	Black	—	0	0	0	0	0	0	0	0	0	0	0	0	0	0	0	0	0
	Blue	—	0	0	0	0	0	0	0	0	0	0	0	1	1	1	1	1	1
	Green	—	0	0	0	0	0	0	1	1	1	1	1	0	0	0	0	0	0
	Cyan	—	0	0	0	0	0	0	1	1	1	1	1	1	1	1	1	1	1
	Red	—	1	1	1	1	1	1	0	0	0	0	0	0	0	0	0	0	0
	Magenta	—	1	1	1	1	1	1	0	0	0	0	0	0	1	1	1	1	1
	Yellow	—	1	1	1	1	1	1	1	1	1	1	1	1	0	0	0	0	0
	White	—	1	1	1	1	1	1	1	1	1	1	1	1	1	1	1	1	1
Gray Scale of Red	Black	GS0	0	0	0	0	0	0	0	0	0	0	0	0	0	0	0	0	
	↑	GS1	1	0	0	0	0	0	0	0	0	0	0	0	0	0	0	0	
	Darker	GS2	0	1	0	0	0	0	0	0	0	0	0	0	0	0	0	0	
	↑	↓				↓				↓						↓			
	↓	↓				↓				↓						↓			
	Brighter	GS61	1	0	1	1	1	1	0	0	0	0	0	0	0	0	0	0	
	↓	GS62	0	1	1	1	1	1	0	0	0	0	0	0	0	0	0	0	
	Red	GS63	1	1	1	1	1	1	0	0	0	0	0	0	0	0	0	0	
Gray Scale of Green	Black	GS0	0	0	0	0	0	0	0	0	0	0	0	0	0	0	0	0	
	↑	GS1	0	0	0	0	0	0	1	0	0	0	0	0	0	0	0	0	
	Darker	GS2	0	0	0	0	0	0	0	1	0	0	0	0	0	0	0	0	
	↑	↓				↓				↓						↓			
	↓	↓				↓				↓						↓			
	Brighter	GS61	0	0	0	0	0	0	1	0	1	1	1	1	0	0	0	0	
	↓	GS62	0	0	0	0	0	0	0	1	1	1	1	1	0	0	0	0	
	Green	GS63	0	0	0	0	0	0	1	1	1	1	1	1	0	0	0	0	
Gray Scale of Blue	Black	GS0	0	0	0	0	0	0	0	0	0	0	0	0	0	0	0	0	
	↑	GS1	0	0	0	0	0	0	0	0	0	0	0	1	0	0	0	0	
	Darker	GS2	0	0	0	0	0	0	0	0	0	0	0	0	1	0	0	0	
	↑	↓				↓				↓						↓			
	↓	↓				↓				↓						↓			
	Brighter	GS61	0	0	0	0	0	0	0	0	0	0	0	0	1	0	1	1	
	↓	GS62	0	0	0	0	0	0	0	0	0	0	0	0	0	1	1	1	
	Blue	GS63	0	0	0	0	0	0	0	0	0	0	0	0	1	1	1	1	

0 : Low level voltage, 1 : High level voltage

Each basic color can be displayed in 64 gray scales from 6 bit data signals. According to the combination of total 18 bit data signals, the 262,144-color display can be achieved on the screen.

## 10. Optical Characteristics

Ta=+25°C, Vcc=+3.3V

Parameter		Symbol	Condition	Min.	Typ.	Max.	Unit	Remark
Viewing angle range	Horizontal	$\theta_{21}, \theta_{22}$	CR>10	60	70	—	Deg.	[Note 1,3,6]
	Vertical	$\theta_{11}$		40	50	—	Deg.	
		$\theta_{12}$		50	60			
Contrast ratio		CRn	$\theta = 0^\circ$	300	—	—		[Note 2,4,6]
		CRo	Optimum viewing angle	300	450	—		
Response time		$\tau_r + \tau_d$	$\theta = 0^\circ$	—	30	60	ms	[Note 2,4,6]
Chromaticity of white		x		0.264	0.314	0.364		[Note 2,6]
		y		0.284	0.334	0.384		
Luminance of white [Note 2,6]		Y <sub>LI</sub>		250	350	—	cd/m <sup>2</sup>	D <sub>PWM</sub> = 100%
White Uniformity		$\delta_w$		—	1.10	1.30		[Note 2,7]

※ The measurement shall be executed 30 minutes after lighting at rating. Condition : D<sub>PWM</sub> = 100%

The optical characteristics shall be measured in a dark room or equivalent.

[Note 1] Measuring Viewing Angle Range

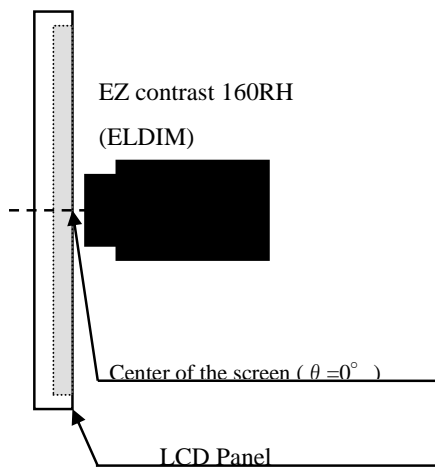

[Note 2] Other Measurements

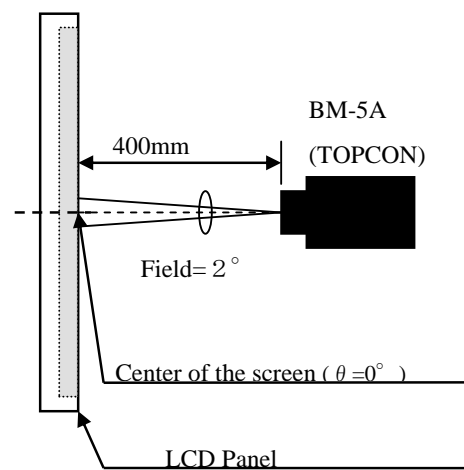

[Note 3] Definitions of viewing angle range:

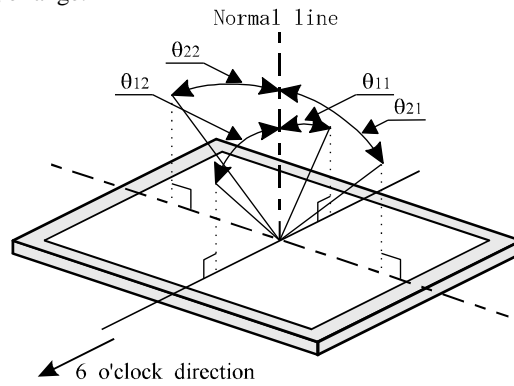

[Note 4] Definition of contrast ratio:

The contrast ratio is defined as the following.

$$\text{Contrast Ratio (CR)} = \frac{\text{Luminance (brightness) with all pixels white}}{\text{Luminance (brightness) with all pixels black}}$$

[Note 5] Definition of response time:

The response time is defined as the following figure and shall be measured by switching the input signal for "black" and "white" .

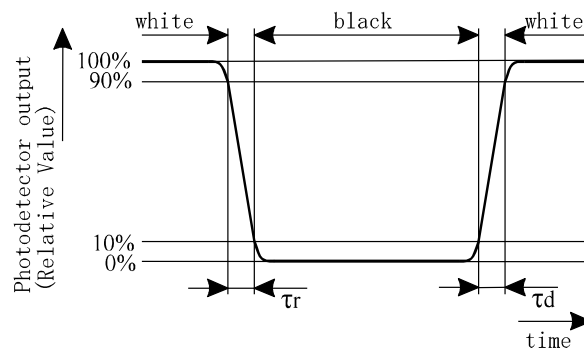

[Note 6] This shall be measured at center of the screen.

[Note 7] Definition of white uniformity:

White uniformity is defined as the following with five measurements (A~E).

$$\delta_w = \frac{\text{Maximum Luminance of five points (brightness)}}{\text{Minimum Luminance of five points (brightness)}}$$

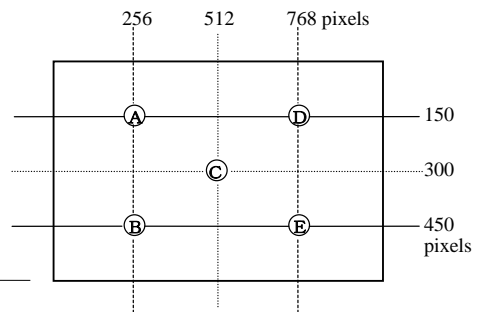

### 11. Display Quality

The display quality of the color TFT-LCD module shall be in compliance with the Incoming Inspection Standard.

## 12. Design guidance for touchpanel(T/P)

## 12 - 1. Example of housing design

(1) If a consumer will put a palm on housing in normal usage, care should be taken as follows.

(2) Keep the gap, for example 0.3 to 0.7mm, between bezel edge and T/P surface.

The reason is to avoid the bezel edge from contacting T/P surface that may cause a "short" with bottom layer (See Fig.4)

(3) Insertion of a cushion material is recommended.

(4) The cushion material should be limited just on the busbar insulation paste area.

If it is over the transparent insulation paste area, a "short" may be occurred.

(5) There is one where a resistance film is left in the T/P part of the end of the pole.

Design to keep insulation from the perimeter to prevent from mis-operation and so on.

## 12 - 2. Mounting on display and housing bezel

(1) In all cases, the T/P should be supported from the backside of the glass.

(2) Do not use an adhesive-tape to bond it on the front of T/P and hang it to the housing bezel.

(3) Never expand the T/P top layer (PET-film) like a balloon by internal air pressure.

The life of the T/P will be extremely short.

(4) Top layer, PET, dimension is changing with environmental temperature and humidity.

Avoid a stress from housing bezel to top layer, because it may cause "waving".

(5) The input to the Touchpanel sometimes distorts touch panel itself.

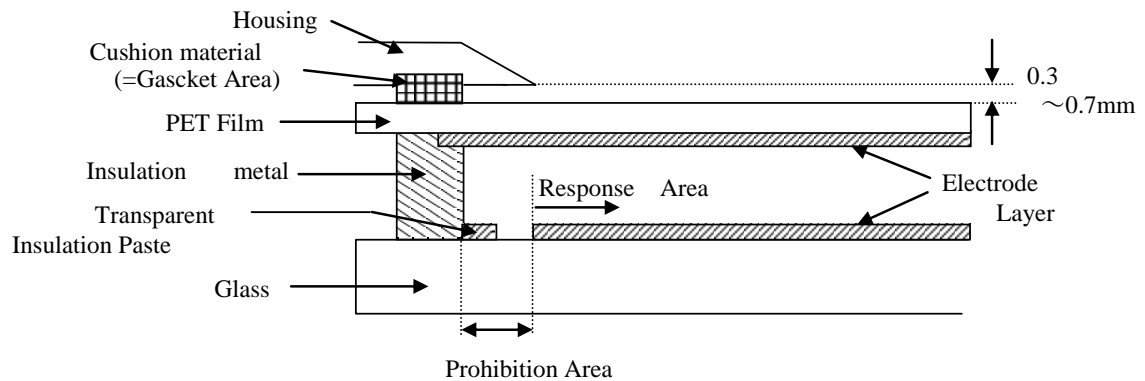

### 13. Handling Precautions

- a) Be sure to turn off the power supply when inserting or disconnecting the cable.
- b) Be sure to design the cabinet so that the module can be installed without any extra stress such as warp or twist.
- c) Since the touch panel surface is easily damaged, pay attention not to scratch it.
- d) Wipe off water drop immediately. Long contact with water may cause discoloration or spots.
- e) When the panel surface is soiled, wipe it with absorbent cotton or other soft cloth.
- f) Since the panel is made of glass, it may break or crack if dropped or bumped on hard surface. Handle with care.
- g) Since CMOS LSI is used in this module, take care of static electricity and injure the human earth when handling.  
Observe all other precautionary requirements in handling components.
- h) This module has its circuitry PCBs on the rear side and should be handled carefully in order not to be stressed.
- i) Protect sheet is attached to the module surface to prevent it from being scratched. Peel the sheet off slowly just before the use with strict attention to electrostatic charges. Ionized air shall be blown over during the action. Blow off the 'dust' on the polarizer by using an ionized nitrogen gun, etc..
- j) Do not expose the LCD module to a direct sunlight, for a long period of time to protect the module from the ultra violet ray.
- k) Connect GND of module bezel to stabilize against EMI and external noise.
- l) When handling LCD modules and assembling them into cabinets, please be noted that long-term storage in the environment of oxidization or deoxidization gas and the use of such materials as reagent, solvent, adhesive, resin, etc. which generate these gasses, may cause corrosion and discoloration of the LCD modules.
- m) Adjusting volume have been set optimally before shipment, so do not change any adjusted value. If adjusted value is changed, the specification may not be satisfied.
- n) Disassembling the module can cause permanent damage and should be strictly avoided.  
Do not peel off the tapes, and do not remove an internal connector.  
The final form of the module is Figure 2.
- o) Please be careful since image retention may occur when a fixed pattern is displayed for a long time.
- p) Please handle carefully not to charge excessive stress onto the back of the module. Excessive stress may cause unrepairable damage to the module.
- q) Don't give stress on the surface of the touch panel continuously. It causes unevenness (in such cases as the Newton's Ring) in the touch panel surface.
- r) Liquid crystal contained in the panel may leak if the LCD is broken. Rinse it as soon as possible if it gets inside your eye or mouth by mistake.

## 14. Packing Form

Piling number of cartons	Max. 8
Package quantity in one carton	100pcs
Carton size	575mm(W)×360mm(D)×225mm(H)
Total mass of one carton filled with full modules	10.8kg
Packing form	Fig.1

## 15. Storage condition

Temperature 0~40°C

Humidity 60% or less  
(no condensation)

Storage term 1 year

Precautions

- Direct sunlight  
Store it in the packing box or the darkroom to avoid direct sunlight.
- Atmosphere  
Do not store in a place the causticity gas may occur or near the volatile solvent.
- Condensation
  - Do not put directly on the floor, and keep the wrapping box on the palette or the stand to avoid the condensation.  
Moreover, arrange it in a constant direction correctly to improve ventilation under the palette.
  - Keep it separate from the wall in the storage warehouse.
  - Note that ventilation is improved and consider the installation such as ventilators in the warehouse.
  - Manage so that there is no rapid temperature change more than natural environment.

## 16. Reliability Test Items

No.	Test item	Conditions
1	High temperature storage test	Ta = 70°C 240h
2	Low temperature storage test	Ta = -25°C 240h
3	High temperature & high humidity operation test	Ta = 40°C ; 95 %RH 240h (No condensation)
4	High temperature operation test	Tp = 60°C 240h (Panel surface temperature)
5	Low temperature operation test	Ta = 0°C 240h
6	Thermal Shock Test (non- operating)	+70°C(1hours) ⇔ -20°C(1hours) 2hours per cycle Temperature change time:10°C/minute Tested for 5 cycles
7	Vibration test (non- operating)	Frequency range: 10~55~10Hz Stroke: 1.5mm Sweep time: 1minutes Test period: 2 hour for each direction of X,Y,Z
8	Shock test (non- operating)	Max. gravity : 980 m/s <sup>2</sup> Pulse width : 6 ms, sine wave Direction : ±X,±Y,±Z 3 times for each direction.
9	Point activation test (Touch panel)	Hit it 1,000,000 times with a silicon rubber of R8 HS 60. Hitting force :4.9N Hitting speed : 3 times per second
10	Writing friction resistance test (Touch panel)	Write according to the right illustration in the under –mentioned conditions: Pen : 0.8R Polyacetal stylus Load : 2.4N Speed : 3 strokes per second Stroke : 30mm Frequency : 50000 times
11	ESD	±200V,200pF(0Ω) 1time/each terminal

[Result Evaluation Criteria] Under the display quality test conditions with normal operation state, these shall be no change, which may affect practical display function.

[Normal operation state] Temperature : +15~+35°C, Humidity : 45~75%, Atmospheric pressure : 86~106kPa

[Touch panel testing apparatus]

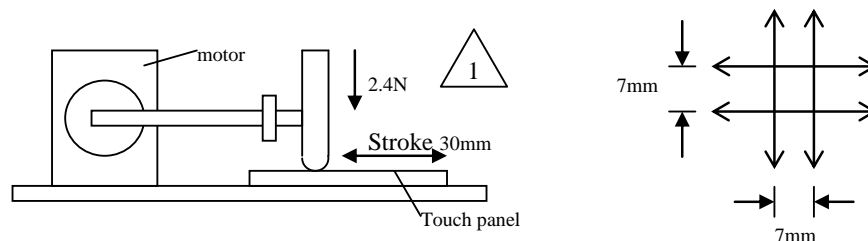



17. Label

1) Module label:

Notation: ①Model No. ②Serial No.

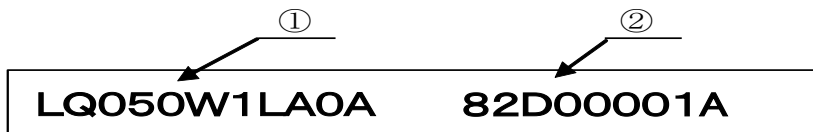

Serial No.

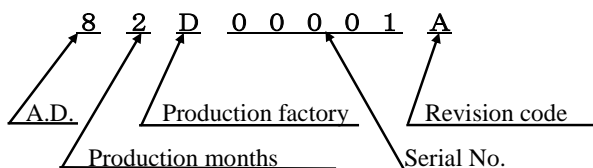

(Production months)

1-9(Jan.-Sep.),X(Oct.),Y(Nov.),Z(Dec)

2) Packing bar code label

Notation/ Bar code: ①Model No. ②Date ③Quantity

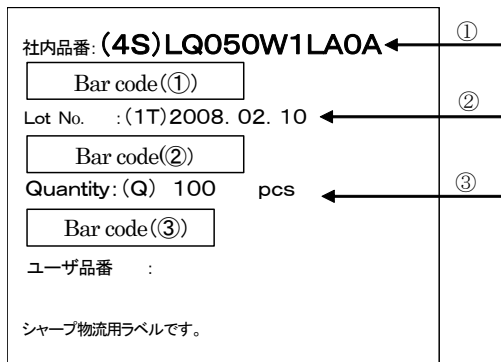

18. RoHS Regulations

This component comply with RoHS Regulations.

Carton mark

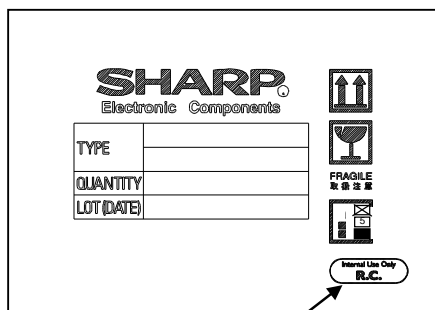

Carton mark (This side and other side)



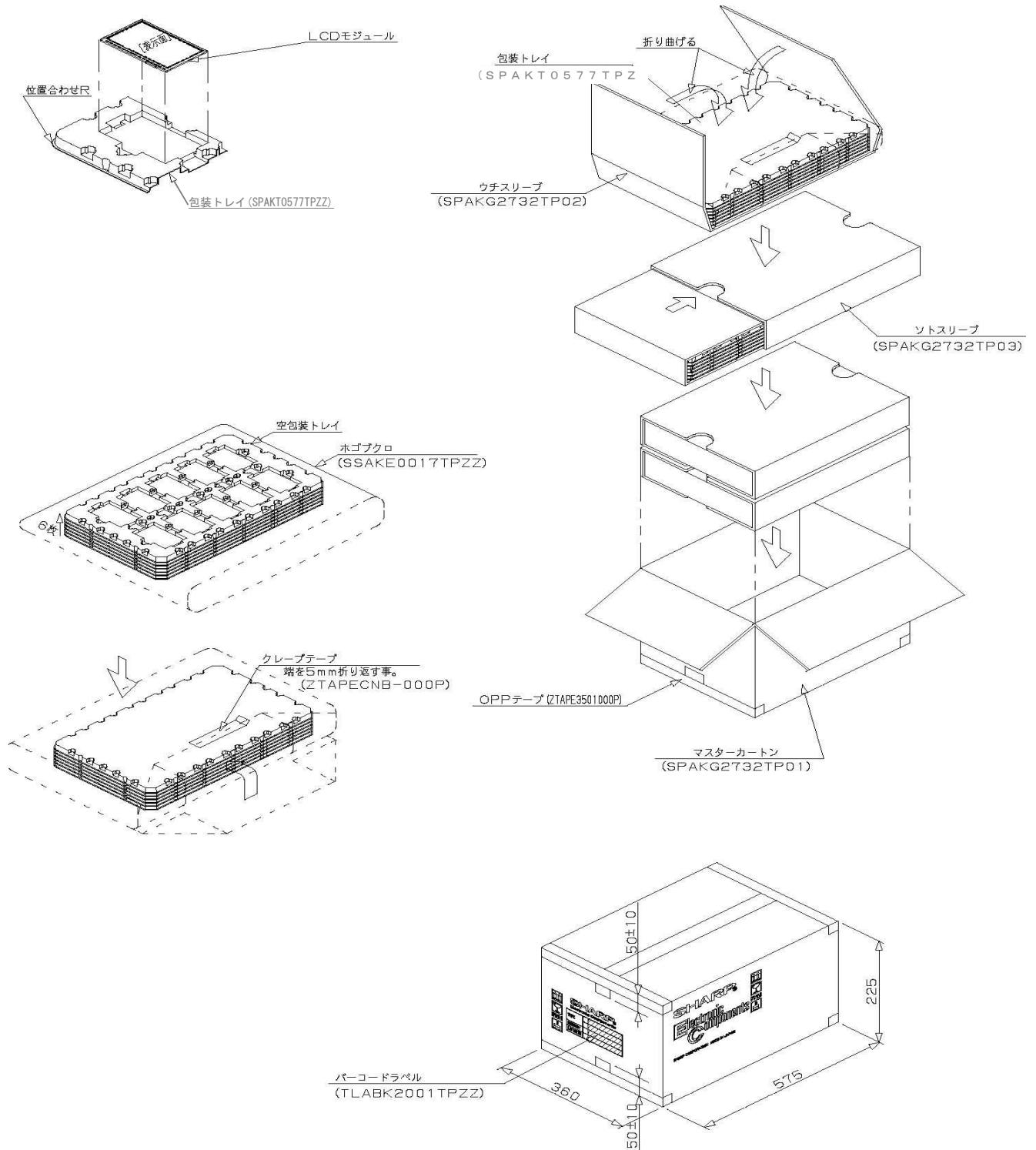

Fig. 1 Packing form



# LCD Specification

## LCD Group



### NORTH AMERICA

Sharp Microelectronics of the Americas  
5700 NW Pacific Rim Blvd.  
Camas, WA 98607, U.S.A.  
Phone: (1) 360-834-8700  
Fax: (1) 360-834-8903  
www.sharpsma.com

### TAIWAN

Sharp Electronic Components  
(Taiwan) Corporation  
8F-A, No. 16, Sec. 4, Nanking E. Rd.  
Taipei, Taiwan, Republic of China  
Phone: (886) 2-2577-7341  
Fax: (886) 2-2577-7326/2-2577-7328

### CHINA

Sharp Microelectronics of China  
(Shanghai) Co., Ltd.  
28 Xin Jin Qiao Road King Tower 16F  
Pudong Shanghai, 201206 P.R. China  
Phone: (86) 21-5854-7710/21-5834-6056  
Fax: (86) 21-5854-4340/21-5834-6057  
Head Office:  
No. 360, Bashen Road,  
Xin Development Bldg. 22  
Waigaoqiao Free Trade Zone Shanghai  
200131 P.R. China  
Email: smc@china.global.sharp.co.jp

### EUROPE

Sharp Microelectronics Europe  
Division of Sharp Electronics (Europe) GmbH  
Sonninstrasse 3  
20097 Hamburg, Germany  
Phone: 49 (0)180 507 35 07  
Fax: (49) 40-2376-2232  
www.sharpsme.com

### SINGAPORE

Sharp Electronics (Singapore) PTE., Ltd.  
438A, Alexandra Road, #05-01/02  
Alexandra Technopark,  
Singapore 119967  
Phone: (65) 271-3566  
Fax: (65) 271-3855

### KOREA

Sharp Electronic Components  
(Korea) Corporation  
RM 501 Geosung B/D, 541  
Dohwa-dong, Mapo-ku  
Seoul 121-701, Korea  
Phone: (82) 2-711-5813 ~ 8  
Fax: (82) 2-711-5819

### JAPAN

Sharp Corporation  
Electronic Components & Devices  
22-22 Nagaïke-cho, Abeno-Ku  
Osaka 545-8522, Japan  
Phone: (81) 6-6621-1221  
Fax: (81) 6117-725300/6117-725301  
www.sharp-world.com

### HONG KONG

Sharp-Roxy (Hong Kong) Ltd.  
Level 26, Tower 1, Kowloon Commerce Centre,  
No. 51, Kwai Cheong Road, Kwai Chung,  
New Territories, Hong Kong  
Phone: (852) 28229311  
Fax: (852) 28660779  
www.sharp.com.hk  
Shenzhen Representative Office:  
Room 602-603, 6/F,  
International Chamber of Commerce Tower,  
168 Fuhua Rd. 3, CBD,  
Futian District, Shenzhen 518048,  
Guangdong, P.R. China  
Phone: (86) 755-88313505  
Fax: (86) 755-88313515

SPECIFICATIONS ARE SUBJECT TO CHANGE WITHOUT NOTICE.

Suggested applications (if any) are for standard use; See Important Restrictions for limitations on special applications. See Limited Warranty for SHARP's product warranty.

The Limited Warranty is in lieu, and exclusive of, all other warranties, express or implied.

ALL EXPRESS AND IMPLIED WARRANTIES, INCLUDING THE WARRANTIES OF MERCHANTABILITY, FITNESS FOR USE AND FITNESS FOR A PARTICULAR PURPOSE, ARE SPECIFICALLY EXCLUDED. In no event will SHARP be liable, or responsible in any way, for any incidental or consequential economic or property damage.