

LQ058T5DRQ1

TFT - LCD Module

(Spec. No.: LCY-01023)

Spec. Issue Date: April 2, 2001

SHARP

No.	LCY- 01023
DATE	Apr . 2. 2001

TECHNICAL LITERATURE
FOR
TFT - LCD module

MODEL No. **LQ058T5DRQ1**

The technical literature is subject to change without notice.
So, please contact Sharp or its representative before designing
your product based on this literature.

SHARP CORPORATION
TFT LIQUID CRYSTAL DISPLAY GROUP
TFT DIVISION.1 MODULE ENGINEERING DEPT.

NOTICE

This publication is the proprietary of SHARP and is copyrighted, with all rights reserved. Under the copyright laws, no part of this publication may be reproduced or transmitted in any form or by any means, electronic or mechanical for any purpose, in whole or in part, without the express written permission of SHARP. Express written permission is also required before any use of this publication may be made by a third party.

The application circuit examples in this publication are provided to explain the representative applications of SHARP's devices and are not intended to guarantee any circuit design or permit any industrial property right or other rights to be executed. SHARP takes no responsibility for any problems related to any industrial property right or a third party resulting from the use of SHARP's devices, except for those resulting directly from device manufacturing processes.

In the absence of confirmation by device specification sheets, SHARP takes no responsibility for any defects that occur in equipment using any of SHARP's devices, shown in catalogs, data books, etc. Contact SHARP in order to obtain the latest device specification sheets before using any SHARP's device.

SHARP reserves the right to make changes in the specifications, characteristics, data, materials, structures and other contents described herein at any time without notice in order to improve design or reliability. Contact SHARP in order to obtain the latest specification sheets before using any SHARP's device. Manufacturing locations are also subject to change without notice.

Observe the following points when using any device in this publication. SHARP takes no responsibility for damage caused by improper use of the devices.

The devices in this publication are designed for use in general electronic equipment designs, such as:

- Car Navigation system
- Automotive auxiliary information display
- Automotive audio visual equipment

The appropriate design measures should be taken to ensure reliability and safety when SHARP's devices are used for equipment such as:

- Transportation control and safety equipment (i.e., aircraft, trains, automobiles, etc.)
- Traffic signals
- Gas leakage sensor breakers
- Alarm equipment
- Various safety devices etc.

SHARP's devices shall not be used for equipment that requires extremely high level of reliability, such as:

- Military and space applications
- Nuclear power control equipment
- Medical equipment for life support

Contact a SHARP representative, in advance, when intending to use SHARP's devices for any "specific" applications other than those recommended by SHARP.

Cold cathode fluorescent lamp in the devices contains a small amount of mercury. Please follow local ordinances or regulations for disposal.

Contact and consult with a SHARP representative if there are any questions about the contents of this publication

(1) Application

This **specification** literature applies to color TFT-LCD module ,LQ058T5DRQ1

(2) Summary and Features

This module is a color active matrix LCD module incorporating amorphous silicon TFT (Thin Film Transistor). It is composed of a color TFT-LCD panel, driver ICs, control-PWB, FPC, frame, front shielding case, back-light unit.

Graphics and texts can be displayed on a 640×3×350 dots panel with 262,144 colors by supplying. DC/AC inverter isn't composed.

The 5.8 screen produces a high resolution image that is composed of 224,000 pixel elements in a stripe arrangement.

Wide viewing angle technology is employed. (The most suitable viewing angle is in the 12 o'clock direction.)

By adopting an active matrix drive, a picture with high contrast is realized.

Through the use of TN-normally white mode, an image with highly natural color image is realized.

It is used the Low-reflection (LR) **and an antiglare (AG)** surface polarization plate.

An inverted video display in the vertical and horizontal directions is possible.

(3) Mechanical specifications

table 3-1

Parameter	Specifications	Units	Remarks
Display format	224,000	pixels	
	640(W)×RGB×350(H)	dots	
Active area	128.6 (W) × 70.35 (H)	mm	
Screen size (Diagonal)	14.7 [5.8"]	cm	
Dot pitch	0.067 (W) × 0.201 (H)	mm	
Pixel configuration	R,G,B Stripe configuration		
Outline dimension	147×89×12.3	mm	[Note3-1]
Mass	185 (MAX)	g	
Surface treatment	AG+LR		

[Note 3-1]

Typical values are given. For detailed measurements and tolerances, please refer to Fig. 1.

(4) Input terminal

4-1) TFT-LCD panel driving part

Used connector: 32FLZ RSM1-R-TB (J.S.T. MFG CO.,LTD)

Table 4-1

CN1

Pin No.	Symbol	Description	Remarks
1	GND	Ground	
2	CLK	Clock signal for sampling each data signal	
3	Hsync	Horizontal synchronous signal	[Note4-1]
4	Vsync	Vertical synchronous signal	[Note4-1]
5	GND	Ground	
6	R0	RED data signal(LSB)	
7	R1	RED data signal	
8	R2	RED data signal	
9	R3	RED data signal	
10	R4	RED data signal	
11	R5	RED data signal(MSB)	
12	GND	Ground	
13	G0	GREEN data signal(LSB)	
14	G1	GREEN data signal	
15	G2	GREEN data signal	
16	G3	GREEN data signal	
17	G4	GREEN data signal	
18	G5	GREEN data signal(MSB)	
19	GND	Ground	
20	B0	BLUE data signal(LSB)	
21	B1	BLUE data signal	
22	B2	BLUE data signal	
23	B3	BLUE data signal	
24	B4	BLUE data signal	
25	B5	BLUE data signal(MSB)	
26	GND	Ground	
27	ENAB	Signal to settle the horizontal display position	[Note4-2]
28	VCC	Power supply voltage	
29	VCC	Power supply voltage	
30	INV	Selection for horizontal and vertical scanning direction	[Note4-3]
31	T0	Thermistor 0	
32	T1	Thermistor 1	

[Note 4-1]

Hsync	Negative
Vsync	Negative

[Note 4-2]

The horizontal display start timing is settled in accordance with a rising timing of ENAB signal. In case ENAB is fixed "Low", the horizontal start timing is determined as described in Fig3.

(Don't keep ENAB "High" during operation.)

[Note 4-3]

INV = "High" : Regular video

INV = "Low" : Horizontally and Vertically inverted video

4-2) Back-light fluorescent tube driving part

Used connector:BHR-02(8.0)VS-1N(JST Co.,Ltd)

Fit connector:SM02(8.0)B-BHS-1N(JST Co.,Ltd)

Table 4-2

No.	Symbol	i/o	Function	Color of FL cable
1	VL1	I	Input terminal	RED
2	VL2	I	Input terminal	BLACK

Used thermistor :203GT-1(Ishizuka electronics Corporation)=20.0k Ω \pm 3%

(5)Absolute maximum ratings

Table 5-1

GND = 0 V

Parameter	Symbol	MIN	MAX	Unit	Note
Input voltage	V _I	-0.3	VCC+0.3	V	【Note 5-1】 Ta=25°C
+3.3V power supply	VCC	0	5	V	Ta = 25°C
Storage temperature	T _{stg}	-40	+95	°C	【Note 5-2】
Operating temperature (panel surface)	T _{opr1}	-30	+85	°C	【Note 5-2】
Operating temperature (Ambient temperature)	T _{opr2}	-30	+60	°C	【Note 5-2】

【Note 5-1】 CK,R0~R5,G0~G5,B0~B5,Hsync,Vsync,ENAB,HVR

【Note 5-2】 Humidity:95%RH Max. at Ta \leq 60°C

Maximum wet-bulb temperature is less than 58°C.

Condensation of dew must be avoided as electrical current leaks will occur,causing a degradation of performance specifications.

(6)Electrical characteristics

6-1)TFT-LCD panel driving section

Table 6-1

GND = 0 V, Ta = 25°C

Parameter	Symbol	MIN	TYP	MAX	Unit	Remarks	
+3.3V	Supply voltage	V _{CC}	+3.0	+3.3	+3.6	V	【Note 6-1】
	Current dissipation	I _{CC}	—	300	340	mA	【Note 6-2,3】
Permissive input ripple	V _{RF}	—	—	100	mVpp		
Input Low voltage	V _{IL}	—	—	0.3VCC	V	【Note 6-4】	
Input High voltage	V _{IH}	0.7VCC	—	—	V		
Input current (Low)	I _{IL}	—	—	10	μ A	V _I =0V 【Note 6-5】	
Input current (High)	I _{IH}	—	—	10	μ A	V _I =VCC 【Note 6-5】	
Input current (Low)	I _{IL}	6.0	—	150	μ A	V _I =0V 【Note 6-6】	
Input current (High)	I _{IH}	—	—	2.0	μ A	V _I =VCC 【Note 6-6】	

【Note 6-1】

On-off conditions for supply voltage

- $0 < t1 \leq 10\text{ms}$
- $0 < t2 \leq 10\text{ms}$
- $0 < t3 \leq 1\text{s}$
- $t4 \geq 1\text{s}$

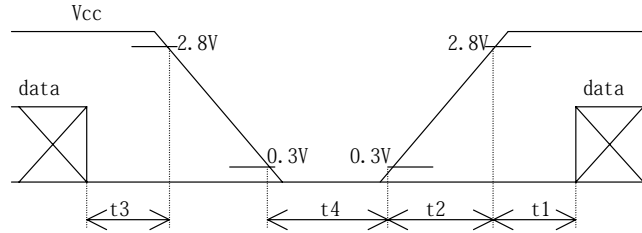

Vcc-dip conditions

- 1) $2.8\text{V} \leq V_{cc} < 3.0\text{V}$
 $t_d \leq 10\text{ms}$
- 2) $V_{cc} < 2.8\text{V}$
Vcc-dip conditions should also follow the on-off conditions.

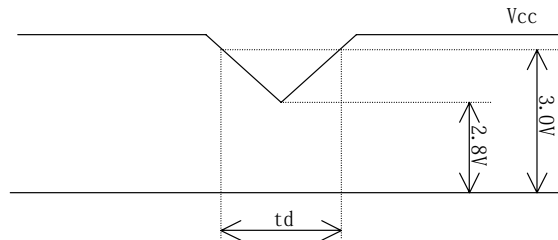

【Note 6-2】

Typical current situation: Black (GS0) pattern

Timing: Typical
VCC= 3.3 V

Black (GS0)

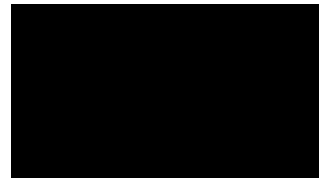

【Note 6-3】 Maximum current situation: Vertical stripe pattern alternating 21 gray scale (GS21) with Black (GS0) every 1 dot.

Timing: Typical
VCC= +3.3 V

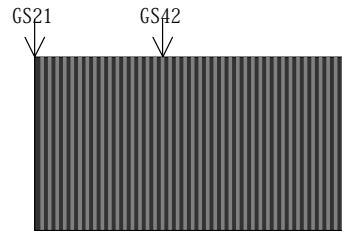

【Note 6-4】 CK,R0~R5,G0~G5,B0~B5,Hsync,Vsync,ENAB,HVR

【Note 6-5】 CK,R0~R5,G0~G5,B0~B5,Hsync,Vsync,ENAB

【Note 6-6】 HVR

6-2) Backlight driving section

The backlight system is an edge-lighting type with single CCFT (Cold Cathode Fluorescent Tube). The characteristics of Lamp are shown in the following table.

Table 6-2

Parameter	Symbol	MIN	TYP	MAX	Unit	Remarks
lamp voltage	V L 7	740	840	940	Vrms	I L = 5.5mArms
lamp current	I L	5.0	5.5	6.0	mArms	ordinary state
	I L B	—	—	9.0	mArms	PWM dimming state 【Note 6-7】
lamp frequency	f L	30	—	60	kHz	
kick-off voltage	V S	—	—	2350	Vrms	Ta=+25°C
		—	—	2400	Vrms	Ta=-30°C

Inverter : HIU-359A-W2[Harison electric co.,ltd] (Output capacitor:18pF,frequency:49kHz)

【Note 6-7】 available area

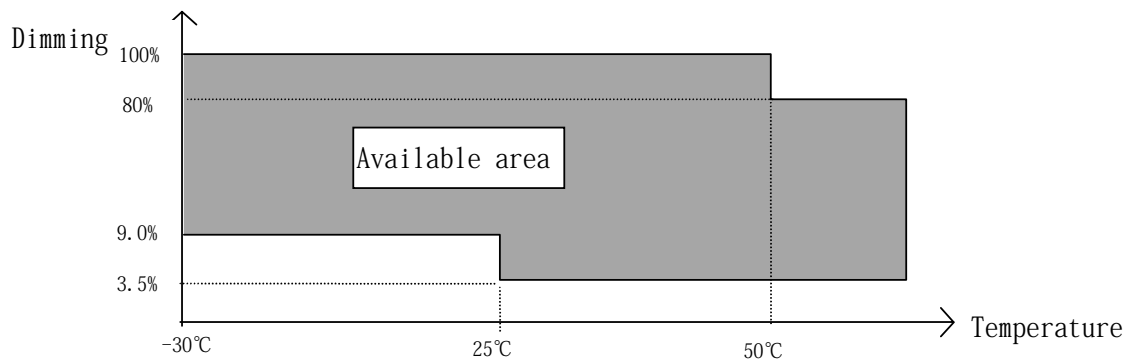

7) Timing Characteristics of input signals

Timing diagrams of input signal are shown in Fig.3

7-1) Timing characteristics

Table 7-1

Parameter		Symbol	MIN	TYP	MAX	Unit	Remarks
Clock	Frequency	1/Tc	—	25.18	27.6	MHz	
	High time	Tch	5	—	—	ns	
	Low time	Tcl	10	—	—	ns	
	Duty ratio	Th/t	40	50	60	%	
Data	Setup time	Tds	5	—	—	ns	
	Hold time	Tdh	10	—	—	ns	
Horizontal sync. signal	Cycle	TH	30	31.78	—	μs	
			770	800	900	clock	
	Pulse width	THp	2	96	200	clock	
Vertical sync. signal	Cycle	TV	515	525	560	line	
	Pulse width	TVp	2	96	200	line	
Horizontal display period		THd	640	640	640	clock	
Hsync-Clock phase difference		THc	10	—	Tc-10	ns	
Hsync-Vsync phase difference		TVh	1	—	Tc-THp	clock	
Vertical display start position		TVs	103	103	103	Line	
Vertical data period		TVd	350	350	350	Line	

Note) In case of lower frequency, the deterioration of display quality, flicker etc., may be occurred.

7-2) Horizontal display position

① In case ENAB is active

The horizontal display position is determined by ENAB signal. The input data corresponding to the 5 edge from rising of ENAB signal is displayed at the left end of the active area. (shown in Fig.3)

Parameter		symbol	Min.	Typ.	Max.	Unit	Remark
Enable signal	Setup time	Tes	5	—	Tc-10	ns	
	Pulse width	Tep	2	640	640	clock	
Hsync-Enable signal phase Difference		THE	44	—	TH-644	clock	

② In case ENAB is "Low"

The display starts from the data of C108(clock) as shown in Fig.3.

Be careful that the module does not work when ENAB is Hi fixed.

7-3) Vertical display position

ENAB signal has no relation to the vertical display position.

7-4) Input Data Signals and Display Position on the screen

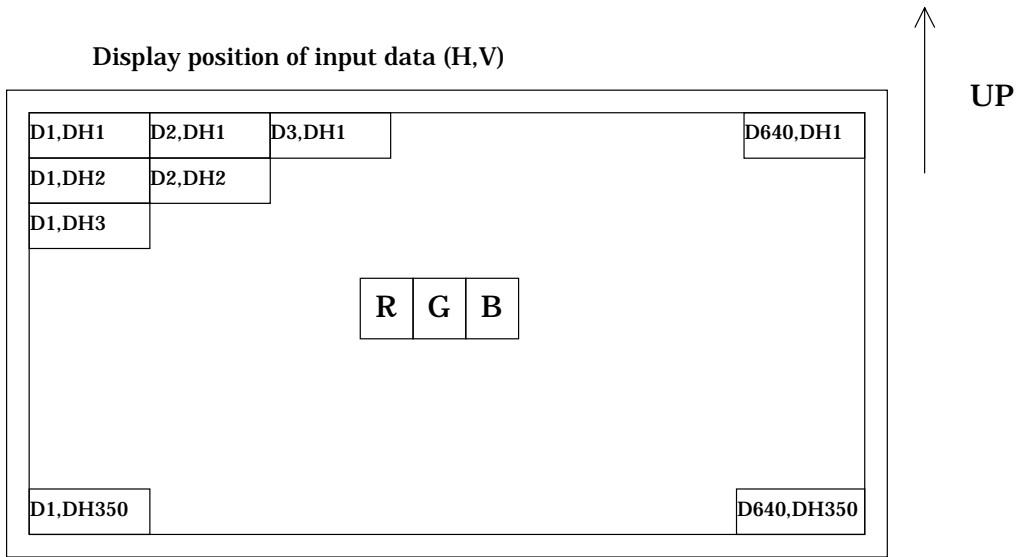

(8) Input Signals, Basic Display Color and Gray Scale of Each Color

	Colors & Gray scale	Data signal																		
		Gray Scale	R0	R1	R2	R3	R4	R5	G0	G1	G2	G3	G4	G5	B0	B1	B2	B3	B4	B5
Basic color	Black	—	0	0	0	0	0	0	0	0	0	0	0	0	0	0	0	0	0	0
	Blue	—	0	0	0	0	0	0	0	0	0	0	0	0	1	1	1	1	1	1
	Green	—	0	0	0	0	0	0	1	1	1	1	1	1	0	0	0	0	0	0
	Cyan	—	0	0	0	0	0	0	1	1	1	1	1	1	1	1	1	1	1	1
	Red	—	1	1	1	1	1	1	0	0	0	0	0	0	0	0	0	0	0	0
	Magenta	—	1	1	1	1	1	1	0	0	0	0	0	0	1	1	1	1	1	1
	Yellow	—	1	1	1	1	1	1	1	1	1	1	1	1	0	0	0	0	0	0
	White	—	1	1	1	1	1	1	1	1	1	1	1	1	1	1	1	1	1	1
Gray Scale of red	Black	GS0	0	0	0	0	0	0	0	0	0	0	0	0	0	0	0	0	0	0
	↑	GS1	1	0	0	0	0	0	0	0	0	0	0	0	0	0	0	0	0	0
	Darker	GS2	0	1	0	0	0	0	0	0	0	0	0	0	0	0	0	0	0	0
	↑	↓				↓				↓				↓				↓		
	↓	↓				↓				↓				↓				↓		
	Brighter	GS61	1	0	1	1	1	1	0	0	0	0	0	0	0	0	0	0	0	0
	↓	GS62	0	1	1	1	1	1	0	0	0	0	0	0	0	0	0	0	0	0
	Red	GS63	1	1	1	1	1	1	0	0	0	0	0	0	0	0	0	0	0	0
Gray Scale of green	Black	GS0	0	0	0	0	0	0	0	0	0	0	0	0	0	0	0	0	0	0
	↑	GS1	0	0	0	0	0	0	1	0	0	0	0	0	0	0	0	0	0	0
	Darker	GS2	0	0	0	0	0	0	0	1	0	0	0	0	0	0	0	0	0	0
	↑	↓				↓				↓				↓				↓		
	↓	↓				↓				↓				↓				↓		
	Brighter	GS61	0	0	0	0	0	0	1	0	1	1	1	1	0	0	0	0	0	0
	↓	GS62	0	0	0	0	0	0	0	1	1	1	1	1	0	0	0	0	0	0
	Green	GS63	0	0	0	0	0	0	1	1	1	1	1	1	0	0	0	0	0	0
Gray Scale of blue	Black	GS0	0	0	0	0	0	0	0	0	0	0	0	0	0	0	0	0	0	0
	↑	GS1	0	0	0	0	0	0	0	0	0	0	0	0	1	0	0	0	0	0
	Darker	GS2	0	0	0	0	0	0	0	0	0	0	0	0	0	1	0	0	0	0
	↑	↓				↓				↓				↓				↓		
	↓	↓				↓				↓				↓				↓		
	Brighter	GS61	0	0	0	0	0	0	0	0	0	0	0	0	1	0	1	1	1	1
	↓	GS62	0	0	0	0	0	0	0	0	0	0	0	0	0	1	1	1	1	1
	Blue	GS63	0	0	0	0	0	0	0	0	0	0	0	0	1	1	1	1	1	1

0 :Low level voltage 1 :High level voltage

Each basic color can be displayed in 64 gray scales from 6 bit data signals. According to the combination of total 18 bit data signals, the 262,144-color display can be achieved on the screen.

(9)Optical characteristics

Table 9-1

Ta=25°C, VCC=+3.3V

Parameter	Symbol	Condition	Min	Typ	Max	Unit	Remarks	
Viewing angle range	$\Delta \theta 11$	$CR \geq 5$	50	55	—	° (degree)	【Note 9-1,4】	
	$\Delta \theta 12$		60	65	—	° (degree)		
	$\Delta \theta 2$		60	65	—	° (degree)		
Contrast ratio	CRmax	Optimal	100	—	—		【Note 9-2,4】	
Response time	Rise	$\theta = 0^\circ$	—	30	60	ms	【Note 9-3,4】	
	Fall		—	50	100	ms		
Luminance	Y	IL=5.5mArms	270	360	—	cd/m ²	【Note 9-5】	
White chromaticity	x	IL=5.5mArms	0.263	0.313	0.363			
	y	IL=5.5mArms	0.279	0.329	0.379			
lamp life time	+25°C	-	continuation	10,000	—	—	hour	【Note 9-6】
	-30°C	-	intermission	2,000	—	—	time	【Note 9-7】

DC/AC inverter for external connection shown in following.

Inverter : HIU-359A-W2[Harison electric co.,ltd] (Output capacitor:18pF,frequency:49kHz)

※measuring after 30minutes

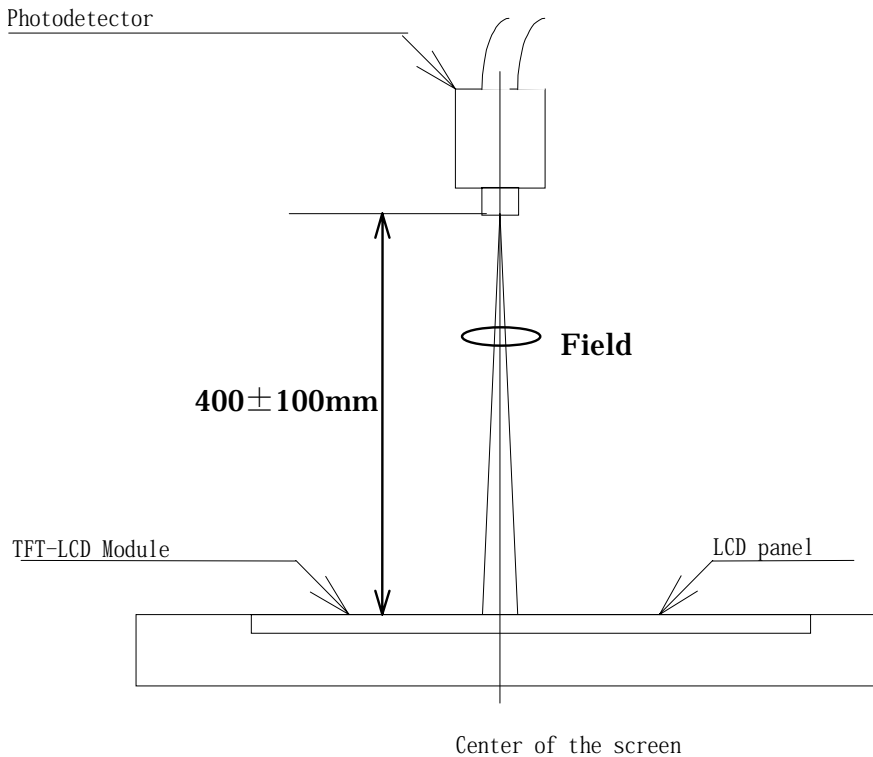
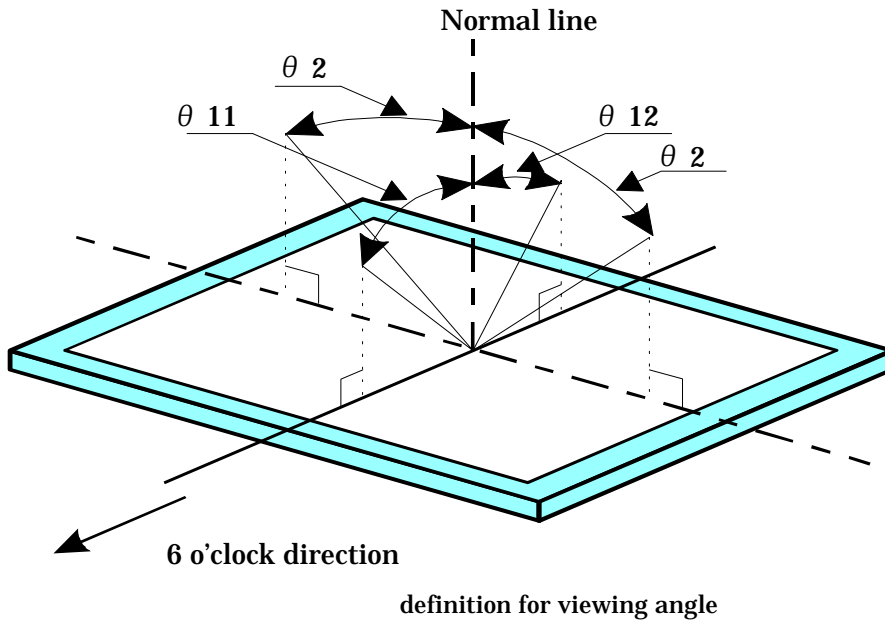

Fig.9-1 Optical characteristics measurement method

【Note 9-1】 Viewing angle range is defined as follows.



【Note 9-2】 Contrast ratio is defined as follows:

$$\text{Contrast ratio(CR)} = \frac{\text{Photo detector output with LCD being "white"}}{\text{Photo detector output with LCD being "black"}}$$

【Note 9-3】 Response time is obtained by measuring the transition time of photo detector output, when input signals are applied so as to make the area "black" to and from "white".

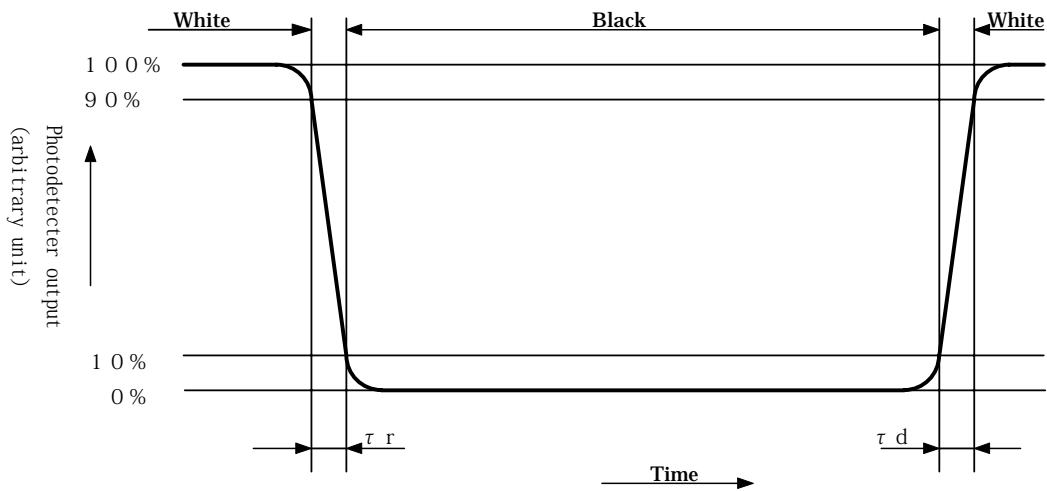

- 【Note 9-4】 Measured on the center area of the panel at a viewing cone 2° (= Filed) by TOPCON luminance meter BM-5A or ELDIM luminance meter EZ Contrast.
(After 30 minutes operation)
DC/AC inverter driving frequency:(49 kHz)
- 【Note 9-5】 Measured on the center area of the panel at a viewing cone 1° (= Filed) by TOPCON luminance meter BM-7.(After 30 minutes operation)
DC/AC inverter driving frequency:(49 kHz)
- 【Note 9-6】 Lamp life time is defined as the time when either or occurs in the continuous operation under the condition of lamp current $I_L=5.5\text{mA rms}$ and PWM dimming 80%~5% ($I_c=9.0\text{mA rms}$ $T_a=25^\circ\text{C}$)
Brightness not to become under 50% of the original value.
- 【Note 9-7】 The intermittent cycles is defined as a time when brightness not to become under 50% of the original value under the condition of following cycle.
Ambient temperature:- 30°C

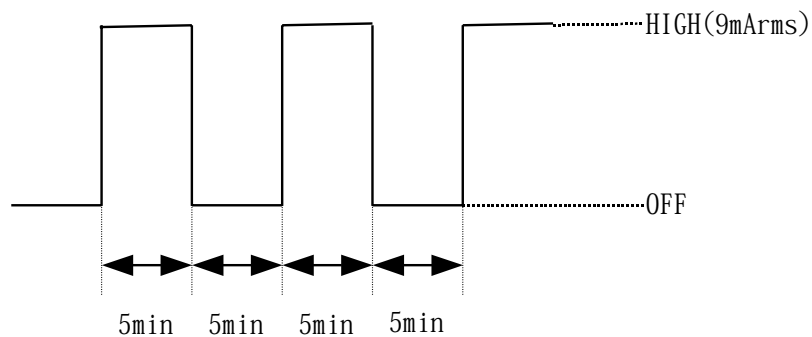

(10)Mechanical characteristics

10-1) External appearance

Do not exist extreme defects. (See Fig. 1)

10-2) Panel toughness

The panel shall not be broken ,when 19N is pressed on the center of the panel by a smooth sphere having 15 mm diameter.

Caution: In spite of very soft toughness, if, in the long-term, add pressure on the active area, it is possible to occur the functional damage.

10-3) Input/output connector performance

A)Input/output connectors for the operation of LCD module

(32 pin [J.S.T. MFG CO.,LTD]) 32FLZ RSM1—R—TB

1)Applicable FPC refer the below figure

2)Terminal holding force : More than 0.9N/pin

(Each terminal is pulled out at a rate of 25 ± 3 mm/min.)

3)Insertion/pulling :contact resistance is not twice larger than the durability initial value after applicable FPC is inserted and pulled out 20 times

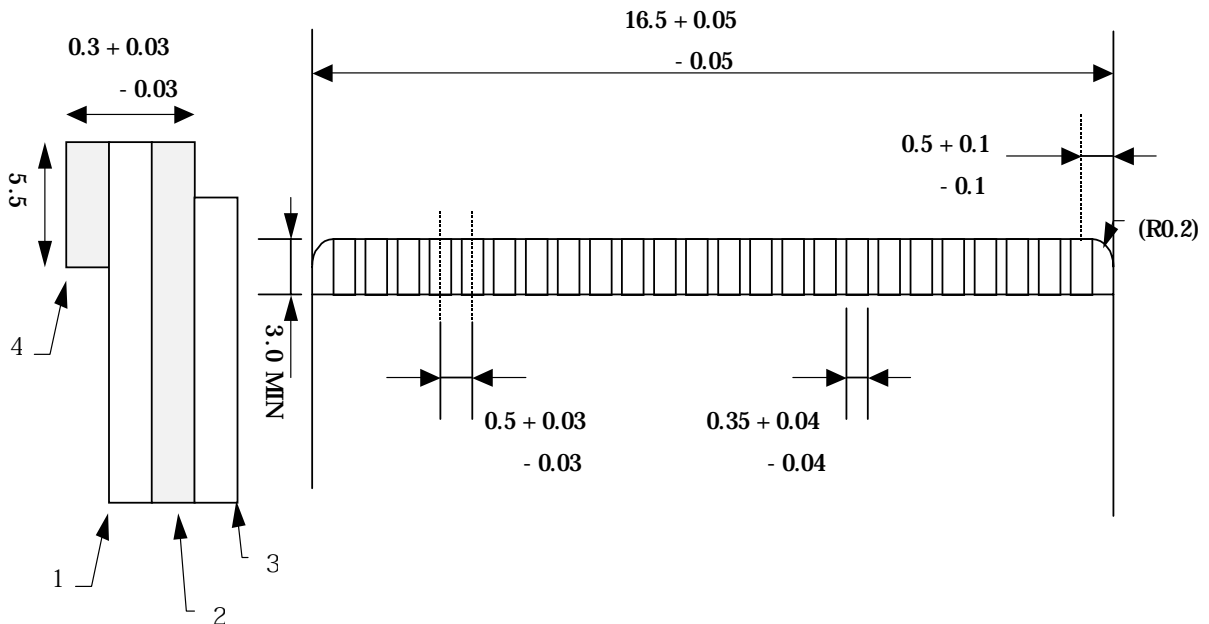

No.	Name	Materials
1	Base material	Polyimide or equivalent material(25 μ m thick)
2	Copper foil	Copper foil(35 μ m thick) Solder plated over 2 μ m
3	Cover lay	Polyimide or equivalent material
4	Reinforcing plate	Polyester polyimide or equivalent material(188 μ m thick)

FPC applied to input/output connector (0.5mm pitch)

B)I/O connector of backlight driving circuit 【JST】

Lump connector

Symbol	Used Connector	Corresponding connector
CNA,B	BHR-02(8.0)VS-1N	SM02(8.0)B-BHS-1N(assembled on PWB)
		SM02(8.0)B-BHS-TB(assembled on PWB)
		BHMR-03V (interconnector)

(11) Display quality

The display quality of the color TFT-LCD module shall be in compliance with the Incoming Inspection Standards for TFT-LCD.

(12) Handling instructions

12-1) Mounting of module

The TFT-LCD module is designed to be mounted on equipment using the mounting tabs in the four corners of the module at the rear side.

On mounting the module, as the M2.6 tapping screw fastening torque is 0.3 through 0.5N·m is recommended, be sure to fix the module on the same plane, taking care not to wrap or twist the module.

Don't reach the pressure of touch-switches of the set side to a module directly, because images may be disturbed.

Please power off the module when you connect the input/output connector.

Please connect the metallic shielding cases of the module and the ground pattern of the inverter circuit surely. If that connection is not perfect, there may be a possibility that the following problems happen.

- a). The noise from the backlight unit will increase.
- b). The output from inverter circuit will be unstable. Then, there may be a possibility that some problems happen.
- c). In some cases, a part of module will heat.

12-2) Precautions in mounting

Polarizer which is made of soft material and susceptible to flaw must be handled carefully.

Protective film (Laminator) is applied on the surface to protect it against scratches and dirties. It is recommended to peel off the laminator immediately before the use, taking care of static electricity.

Precautions in peeling off the laminator

A) Working environment

When the laminator is peeled off, static electricity may cause dust to stick to the polarizer surface. To avoid this, the following working environment is desirable.

- a) Floor: Conductive treatment of 1MΩ or more on the tile
(conductive mat or conductive paint on the tile)

- b) Clean room free from dust and with an adhesive mat on the doorway
- c) Advisable humidity:50%~70% Advisable temperature:15°C~27°C
- d) Workers shall wear conductive shoes, conductive work clothes, conductive gloves and an earth band.

B) Working procedures

- a) Direct the wind of discharging blower somewhat downward to ensure that module is blown sufficiently. Keep the distance between module and discharging blower within 20 cm.
- b) Attach adhesive tape to the laminator part near discharging blower so as to protect polarizer against flow.
- c) Peel off laminator, pulling adhesive tape slowly to your side taking 5 or more second.
- d) On peeling off the laminator, pass the module to the next work process to prevent the module to get dust.

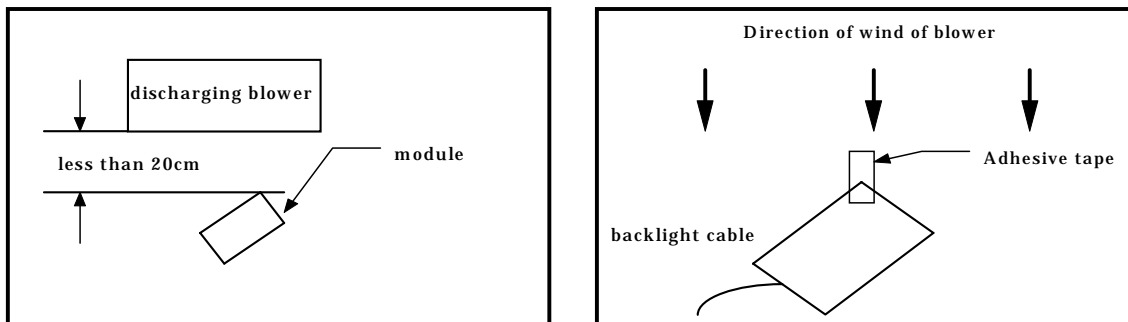

e) Method of removing dust from polarizer

- Blow off dust with N2 blower for which static electricity preventive measure has been taken.
- Since polarizer is vulnerable, wiping should be avoided.
But when the panel has stain or grease, we recommend to use adhesive tape to softly remove them from the panel.

When metal part of the TFT-LCD module (shielding lid and rear case) is soiled, wipe it with soft dry cloth. For stubborn dirties, wipe the part, breathing on it. Wipe off water drop or finger grease immediately. Long contact with water may cause discoloration or spots. TFT-LCD module uses glass which breaks or cracks easily if dropped or bumped on hard surface. Handle with care. Since CMOS LSI is used in this module, take care of static electricity and earth your body when handling.

12-3) Precautions in adjusting module

Adjusting volumes on the rear face of the module have been set optimally before shipment. Therefore, do not change any adjusted values. If adjusted values are changed, the specifications described here may not be satisfied.

12-4) Caution of product design

The LCD module shall be protected against water salt-water by the waterproof cover.

Please take measures to interferential radiation from module, to do not interfere surrounding appliances.

12-5) Others

Do not expose the module to direct sunlight or intensive ultraviolet rays for many hours; liquid crystal is deteriorated by ultraviolet rays. Store the module at a temperature near the room temperature. At lower than the rated storage temperature, liquid crystal solidifies, causing the panel to be damaged. At higher than the rated storage temperature, liquid crystal turns into isotropic liquid and may not recover. The voltage of beginning electric discharge may over the normal voltage because of leakage current from approach conductor by to draw lump read lead line around. If LCD panel breaks, there may be a possibility that the liquid crystal escapes from the panel. Since the liquid crystal is injurious, do not put it into the eyes or mouth. When liquid crystal sticks to hands, feet or clothes, wash it out immediately with soap. Observe all other precautionary requirements in handling general electronic components.

(13) Packing form

Piling number of cartons : MAX 10

Package quantity in one carton 20 pcs

Carton size: 476(W)×398(H)×155(D) mm

Total mass of one carton filled with full modules: 4.5 kg

Conditions for storage.

Environment

①Temperature : 0~40℃

②Humidity : 60%RH or less (at 40℃)

No dew condensation at low temperature and high humidity.

③Atmosphere :Harmful gas, such as acid or alkali which bites electronic components and/or wires, must not be detected.

④Period : about 3 months

⑤Opening of the package : In order to prevent the LCD module from breakdown by electrostatic charges, please control the room humidity over 50%RH and open the package taking sufficient countermeasures against electrostatic charges, such as earth, etc.

(14) Others

Adjusting volume have been set optimally before shipment, so do not change any adjusted value.

If adjusted value is changed, the specification may not be satisfied.

Disassembling the module can cause permanent damage and should be strictly avoided.

Please be careful since image retention may occur when a fixed pattern is displayed for a long time.

Indication of lot number

The lot number is shown on a label. Attached location is shown in Fig.1 (Outline Dimensions).

Indicated contents of the label



model No.

lot No.

- contents of lot No. the 1st figure ··· production year (ex. 1996 : 6)
- the 2nd figure ··· production month 1,2,3,·····,9,X,Y,Z
- the 3rd~8th figure ··· serial No. 000001~
- the 9th figure ··· revision marks A,B,C··

(15) Reliability Test Conditions for TFT-LCD Module

Table 15-1

Remark) Temperature condition is based on operating temperature conditions on (5)-Table 5-1.

No.	Test items	Test conditions
1	High temperature storage test	Ta= +95°C 240h
2	Low temperature storage test	Ta= -40°C 240h
3	High temperature and high humidity operating test	Tp= +60°C , 95%RH 240h
4	High temperature operating test	Tp= +85°C 240h
5	Low temperature operating test	Tp= -30°C 240h
6	Electro static discharge test	±200V · 200pF(0Ω) 1 time for each terminals
7	Shock test	980m/s ² · 6ms, ±X ; ±Y ; ±Z 3 times for each direction (JIS C0041, A-7 Condition C)
8	Vibration test	Frequency range : 8~33.3Hz Stroke : 1.3mm Frequency range : 33.3Hz~400Hz Acceleration : 28.4m/s ² Cycle : 15 minutes X,Z 2 hours for each directions, 4 hours for Y direction (total 8 hours) 【caution】 (JIS D1601)
9	Heat shock test	Ta= (-30)°C~(+85)°C / 200 cycles (0.5h) (0.5h)

【Note】 Ta= Ambient temperature, Tp= Panel temperature

【Check items】 In the standard condition, there shall be no practical problems that may affect the display function.

【caution】 X,Y,Z directions are shown as follows:

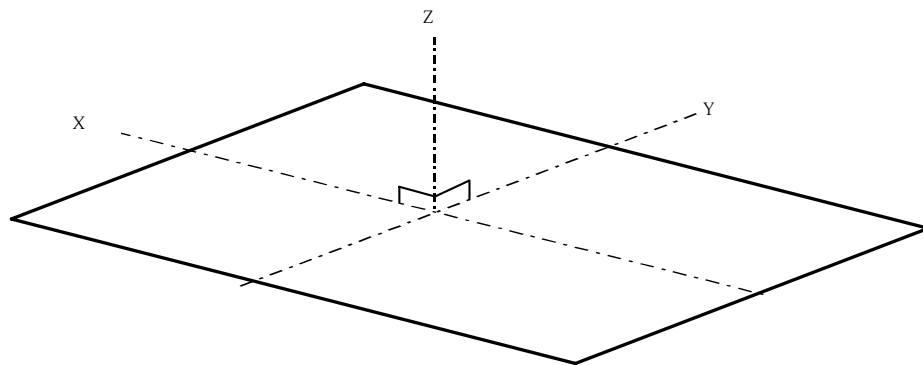

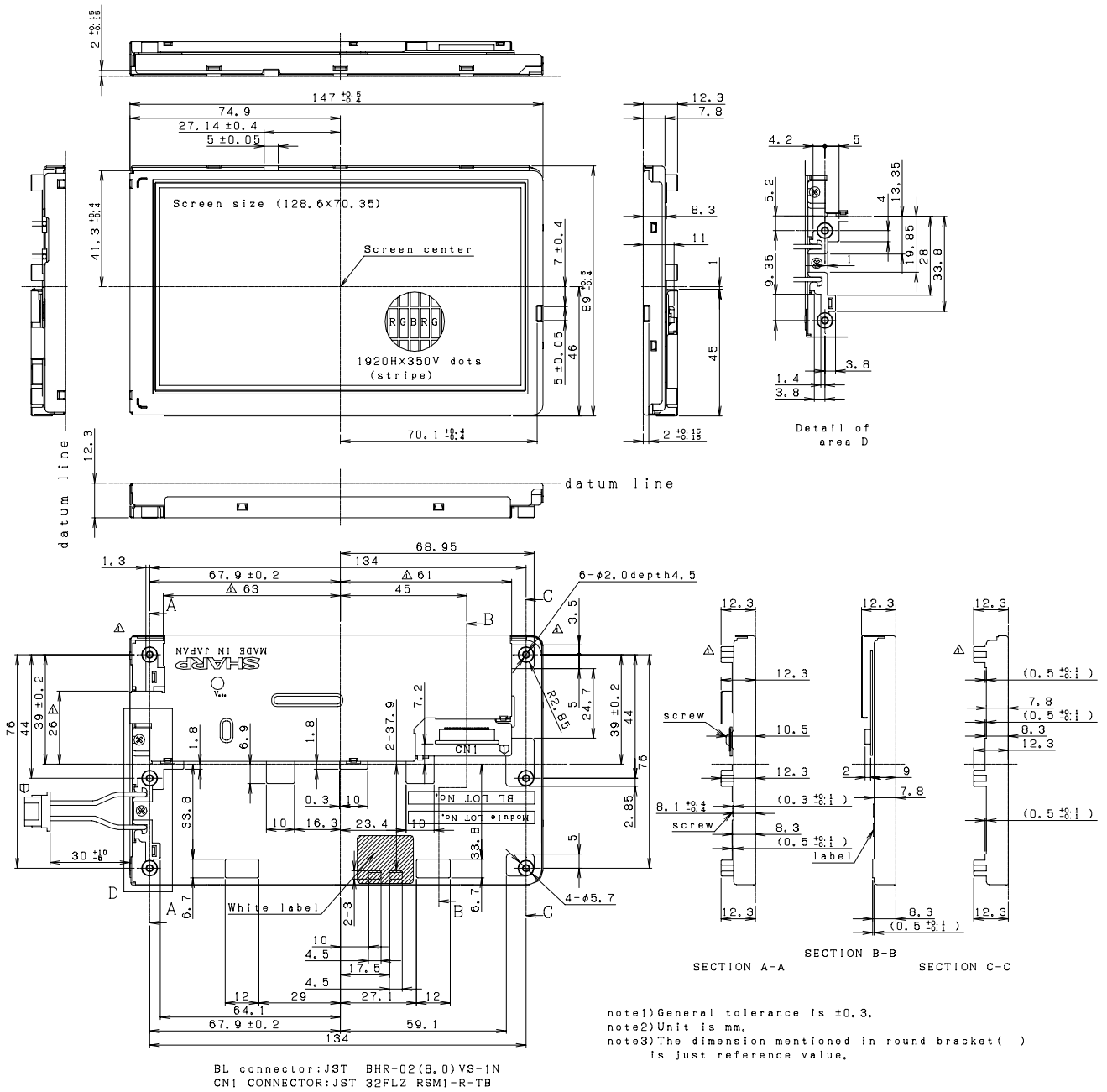

Fig.1 OUTLINE DIMENSIONS

SHARP ORIGINAL MODEL	LQ05BT5DRQ1				
DATE	2000.11.08	Unit: mm	01.09.14	Rear case form change . Base height change	0.00007
DRAWING NO.	LEM-D0001	SCALE: 1/1	No.	DATE	REVISION

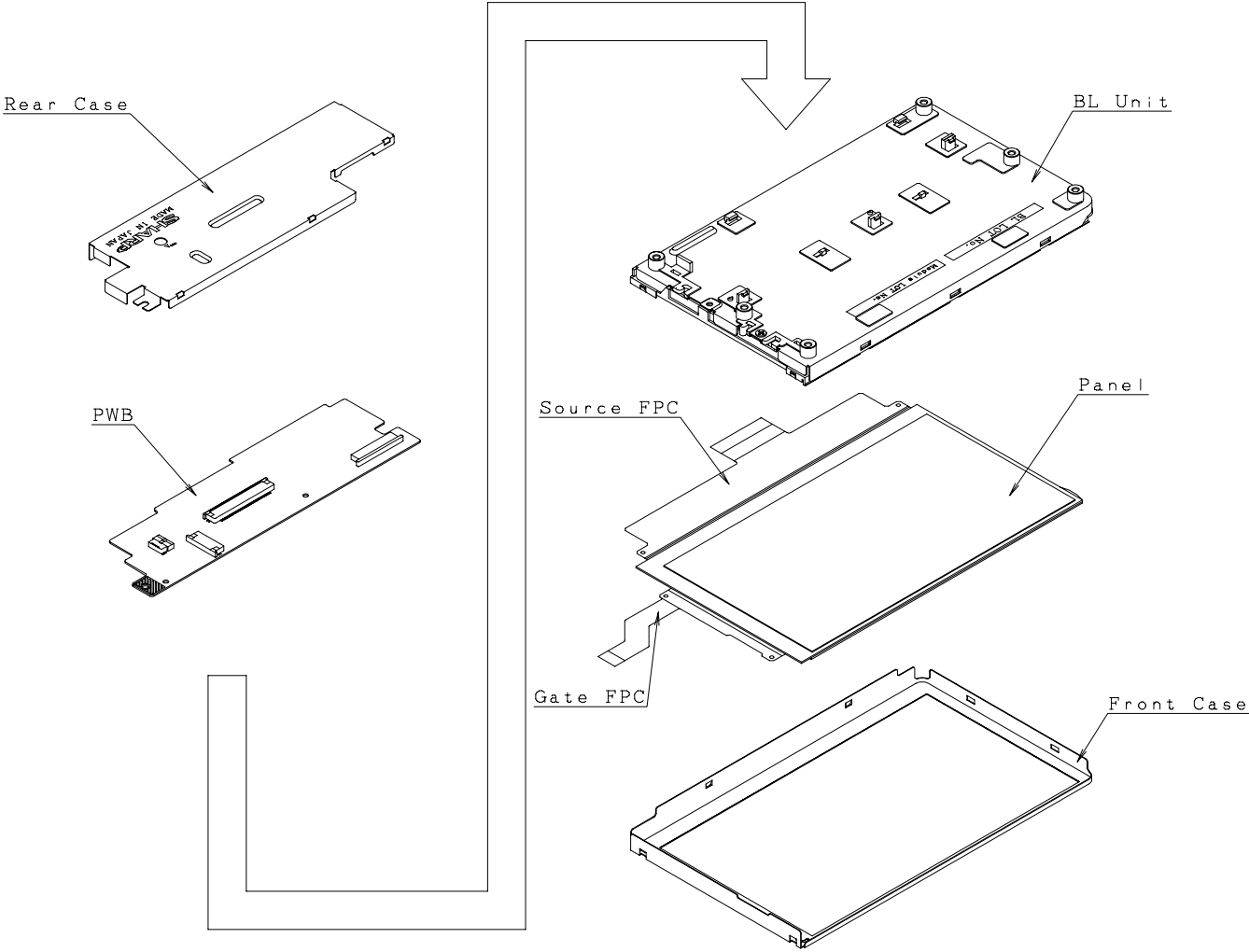
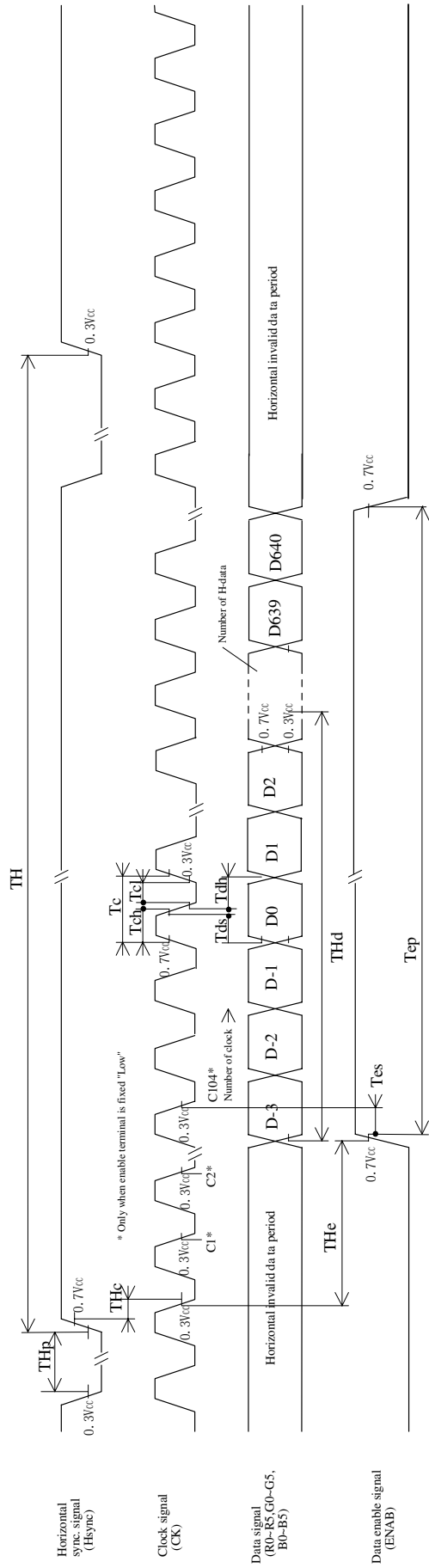

Fig.2 CONSTRUCTION OF TFT-LCD MODULE



D-3~D0 are dummy data. (can't be image)

Fig. 3 Input signal waveforms

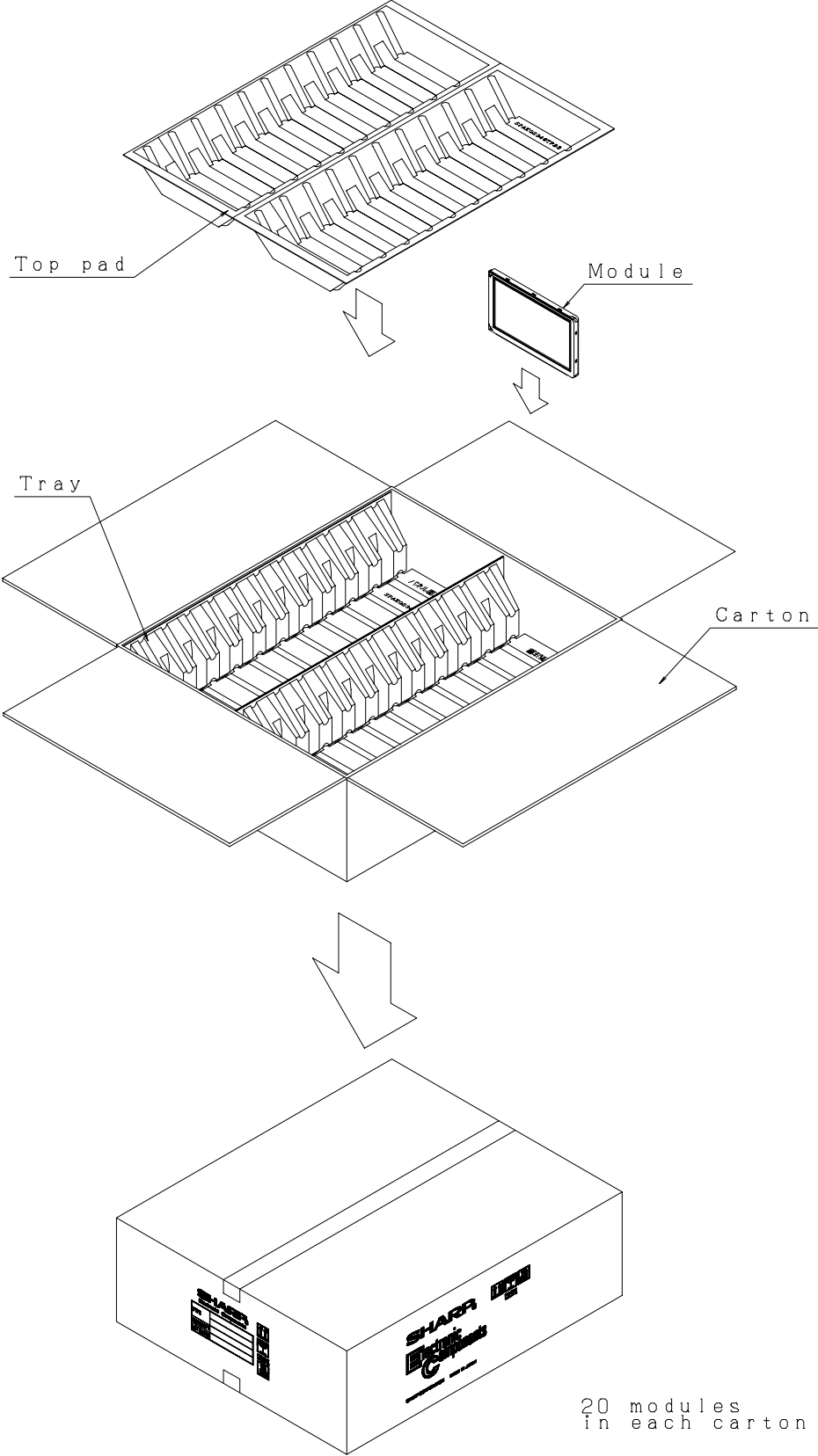
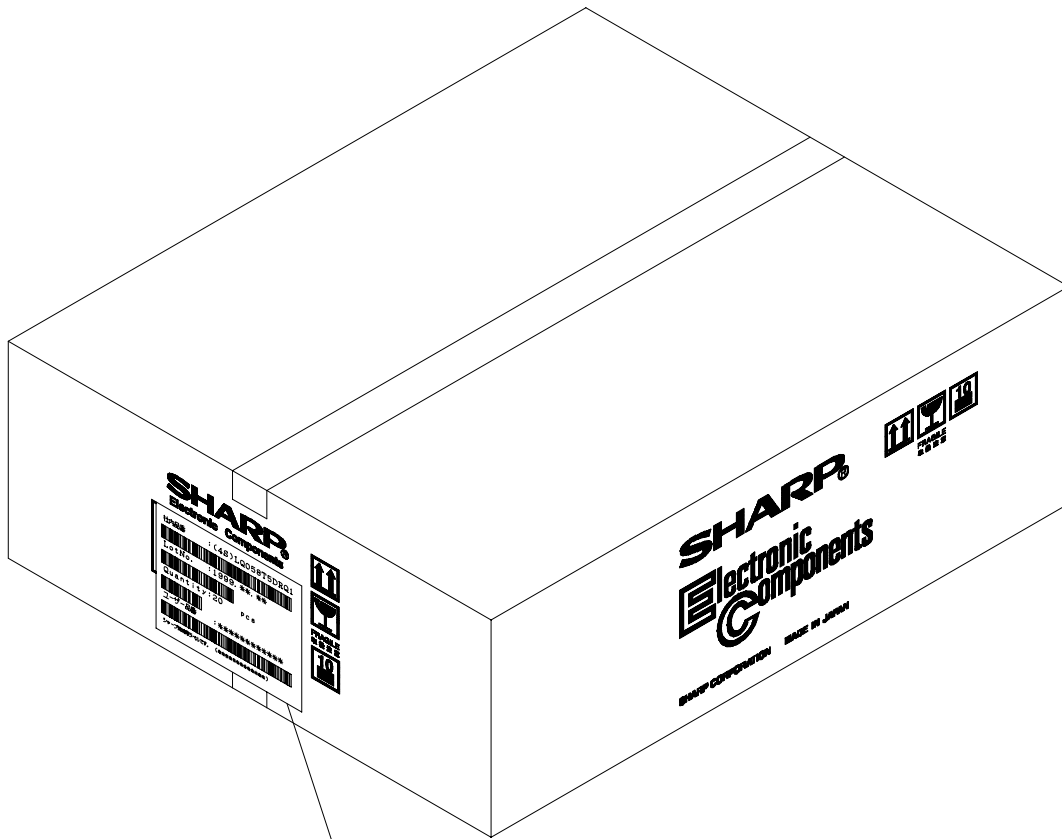

Fig4-1 Packing form







社内品番	: (4S)LQ058T5DRQ1	Model No.
		
LotNo.	: 1999. **. **	LOT No. (date)
		
Quantity	: 20 pcs	Quantity
		
ユーザー品番	: *****	
		
シヤ-プ物流用ラベルです。 (*****)		

Fig4-2 Packing form

SPECIFICATIONS ARE SUBJECT TO CHANGE WITHOUT NOTICE.

Suggested applications (if any) are for standard use; See Important Restrictions for limitations on special applications. See Limited Warranty for SHARP's product warranty. The Limited Warranty is in lieu, and exclusive of, all other warranties, express or implied. ALL EXPRESS AND IMPLIED WARRANTIES, INCLUDING THE WARRANTIES OF MERCHANTABILITY, FITNESS FOR USE AND FITNESS FOR A PARTICULAR PURPOSE, ARE SPECIFICALLY EXCLUDED. In no event will SHARP be liable, or in any way responsible, for any incidental or consequential economic or property damage.

SHARP®

NORTH AMERICA

SHARP Microelectronics of the Americas
5700 NW Pacific Rim Blvd.
Camas, WA 98607, U.S.A.
Phone: (1) 360-834-2500
Fax: (1) 360-834-8903
Fast Info: (1) 800-833-9437
www.sharpsma.com

EUROPE

SHARP Microelectronics Europe
Division of Sharp Electronics (Europe) GmbH
Sonninstrasse 3
20097 Hamburg, Germany
Phone: (49) 40-2376-2286
Fax: (49) 40-2376-2232
www.sharpsme.com

JAPAN

SHARP Corporation
Electronic Components & Devices
22-22 Nagaike-cho, Abeno-Ku
Osaka 545-8522, Japan
Phone: (81) 6-6621-1221
Fax: (81) 6117-725300/6117-725301
www.sharp-world.com

TAIWAN

SHARP Electronic Components
(Taiwan) Corporation
8F-A, No. 16, Sec. 4, Nanking E. Rd.
Taipei, Taiwan, Republic of China
Phone: (886) 2-2577-7341
Fax: (886) 2-2577-7326/2-2577-7328

SINGAPORE

SHARP Electronics (Singapore) PTE., Ltd.
438A, Alexandra Road, #05-01/02
Alexandra Technopark,
Singapore 119967
Phone: (65) 271-3566
Fax: (65) 271-3855

KOREA

SHARP Electronic Components
(Korea) Corporation
RM 501 Geosung B/D, 541
Dohwa-dong, Mapo-ku
Seoul 121-701, Korea
Phone: (82) 2-711-5813 ~ 8
Fax: (82) 2-711-5819

CHINA

SHARP Microelectronics of China
(Shanghai) Co., Ltd.
28 Xin Jin Qiao Road King Tower 16F
Pudong Shanghai, 201206 P.R. China
Phone: (86) 21-5854-7710/21-5834-6056
Fax: (86) 21-5854-4340/21-5834-6057

Head Office:

No. 360, Bashen Road,
Xin Development Bldg. 22
Waigaoqiao Free Trade Zone Shanghai
200131 P.R. China
Email: smc@china.global.sharp.co.jp

HONG KONG

SHARP-ROXY (Hong Kong) Ltd.
3rd Business Division,
17/F, Admiralty Centre, Tower 1
18 Harcourt Road, Hong Kong
Phone: (852) 28229311
Fax: (852) 28660779
www.sharp.com.hk

Shenzhen Representative Office:

Room 13B1, Tower C,
Electronics Science & Technology Building
Shen Nan Zhong Road
Shenzhen, P.R. China
Phone: (86) 755-3273731
Fax: (86) 755-3273735