

# Specification

**LQ10D36A**

**Doc. No.: LD-19Z53A**

**Version December 2007**

**Note: This specification is subject to change without prior notice**



## 1. Application

This technical literature applies to color TFT-LCD module, LQ10D36A

These technical literature sheets are the proprietary product of SHARP CORPORATION("SHARP) and include materials protected under copyright of SHARP. Do not reproduce or cause any third party to reproduce them in any form or by any means, electronic or mechanical, for any purpose, in whole or in part, without the express written permission of SHARP .

The device listed in these technical literature sheets was designed and manufactured for use in general electronic equipment.

In case of using the device for applications such as control and safety equipment for transportation(aircraft, trains, automobiles, etc. ), rescue and security equipment and various safety related equipment which require higher reliability and safety, take into consideration that appropriate measures such as fail-safe functions and redundant system design should be taken .

Do not use the device for equipment that requires an extreme level of reliability, such as aerospace applications, telecommunication equipment(trunk lines), nuclear power control equipment and medical or other equipment for life support .

SHARP assumes no responsibility for any damage resulting from the use of the device which does not comply with the instructions and the precautions specified in these technical literature sheets .

Confirm "11. Handling Precautions " item when you use the device.

Contact and consult with a SHARP sales representative for any questions about this device .

## 2. Overview

This module is a color active matrix LCD module incorporating amorphous silicon TFT (Thin Film Transistor). It is composed of a color TFT-LCD panel, driver ICs, control circuit and power supply circuit and a backlight unit. Graphics and texts can be displayed on a 640 × 3 × 480 dots panel with 262,144 colors by supplying 18 bit data signal (6bit/color), four timing signals,+3.3V/ +5.0V DC supply voltage for TFT-LCD panel driving and supply voltage for backlight.

The TFT-LCD panel used for this module is a low-reflection and higher-color-saturation type. Therefore, this module is also suitable for the multimedia use. Optimum viewing direction is 6 o'clock.

Backlight-driving DC/AC inverter is not built in this module.

### 3. Mechanical Specifications

Parameter	Specifications	Unit
Display size	26 (10.4") Diagonal	cm
Active area	211.2(H) × 158.4(V)	mm
Pixel format	640(H) × 480(V)	pixel
	(1 pixel = R + G + B dots)	
Pixel pitch	0.330(H) × 0.330(V)	mm
Pixel configuration	R,G,B vertical stripe	
Display mode	Normally white	
Unit outline dimensions *1	246.5(W) × 179.4(H) × 11.0max(D)	mm
Mass	520(max)	g
Surface treatment	Anti-glare and hard-coating 3H	

\*1.Note: excluding backlight cables.

Outline dimensions is shown in Fig.1(TBD)

## 4. Input Terminals

### 4-1. TFT-LCD panel driving

Used connector : DF9MA-31P-1V(32) (Hirose Electric Co., Ltd.)

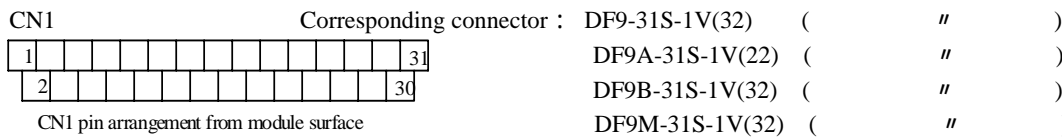

(        ) Do not use it besides corresponding connector.

Pin No.	Symbol	Function	Remark
1	GND		
2	CK	Clock signal for sampling each data signal	
3	Hsync	Horizontal synchronous signal	【Note1】
4	Vsync	Vertical synchronous signal	【Note1】
5	GND		
6	R0	R E D data signal(LSB )	
7	R1	R E D data signal	
8	R2	R E D data signal	
9	R3	R E D data signal	
10	R4	R E D data signal	
11	R5	R E D data signal(MSB)	
12	GND		
13	G0	G R E E N data signal(LSB )	
14	G1	G R E E N data signal	
15	G2	G R E E N data signal	
16	G3	G R E E N data signal	
17	G4	G R E E N data signal	
18	G5	G R E E N data signal(MSB)	
19	GND		
20	B0	B L U E data signal(LSB)	
21	B1	B L U E data signal	
22	B2	B L U E data signal	
23	B3	B L U E data signal	
24	B4	B L U E data signal	
25	B5	B L U E data signal(MSB)	
26	GND		
27	ENAB	Signal to settle the horizontal display position	【Note2】
28	Vcc	+ 3.3/5.0V power supply	
29	Vcc	+ 3.3/5.0V power supply	
30	R/L	Horizontal display mode select signal	【Note3】
31	U/D	Vertical display mode select signal	【Note4】

The shielding case is connected with GND.

【Note1】 480 line, 400 line or 350 line mode is selected by the polarity combination of the both synchronous signals.

Mode	480 lines	400 lines	350 lines
Hsync	Negative	Negative	Positive
Vsync	Negative	Positive	Negative

【Note2】 The horizontal display start timing is settled in accordance with a rising timing of ENAB signal. In case ENAB is fixed "Low", the horizontal start timing is determined as described in 7-2. Do not keep ENAB "High" during operation.

【Note3】 【Note4】

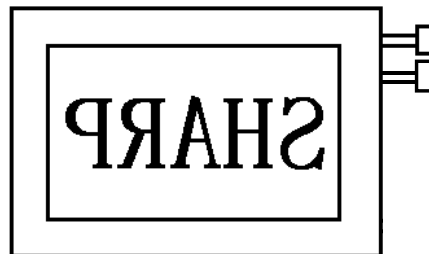
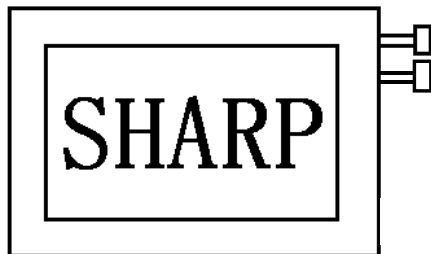

R / L = High、U / D = Low      R / L = Low、U / D = Low

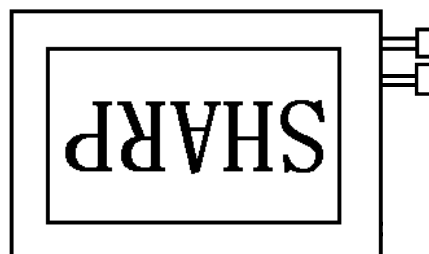
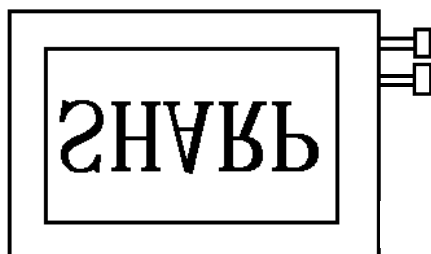

R / L = High、U / D = High      R / L = Low、U / D = High

#### 4-2. Backlight driving

Used connector : BHR-02(8.0)VS-1N (JST)

CN2, CN3

Corresponding connector : SM02(8.0)B-BHS (JST)

Pin no.	Symbol	Function	Cable color
1	V <sub>HIGH</sub>	Power supply for lamp (High voltage side)	Pink
2	NC	This is electrically opened.	
3	V <sub>LOW</sub>	Power supply for lamp (Low voltage side)	White

#### 5. Absolute Maximum Ratings

Parameter	Symbol	Condition	Ratings	Unit	Remark
Input voltage	V <sub>I</sub>	Ta=25	- 0.3 ~ V <sub>CC</sub> + 0.3	V	【Note1】
+5V supply voltage	V <sub>CC</sub>	Ta=25	0 ~ + 6	V	
Storage temperature	T <sub>stg</sub>	-	- 30 ~ + 70		【Note2】
Operating temperature (Ambient)	T <sub>opa</sub>	-	- 10 ~ + 65		

【Note1】 CK, R0 ~ R5, G0 ~ G5, B0 ~ B5, Hsync, Vsync, ENAB, R/L, U/L

【Note2】 Humidity : 95%RH Max. at Ta 40 .

Maximum wet-bulb temperature at 39 or less at Ta>40 .

No condensation.

## 6. Electrical Characteristics

### 6-1. TFT-LCD panel driving

Ta = 25

Parameter		Symbol	Min.	Typ.	Max.	Unit	Remark
Power Supply	Supply voltage	Vcc	+3.0	+3.3   +5.0	+5.5	V	【Note1】
	Current dissipation	Icc	-	(200)	(300)	mA	Vcc=3.3V 【Note2】
		Icc	-	(130)	(200)	mA	Vcc=5.0V 【Note2】
Permissive input ripple voltage		V <sub>RF</sub>	-	-	100	mVp-p	
Input voltage (Low)		V <sub>IL</sub>	-	-	0.8	V	【Note3】
Input voltage (High)		V <sub>IH</sub>	2.1	-	-	V	
Input current (low)		I <sub>OL1</sub>	-	-	1.0	μA	V <sub>I</sub> =0V 【Note4】
		I <sub>OL2</sub>			10	μA	V <sub>I</sub> =0V 【Note5】
		I <sub>OL3</sub>	-	-	800	μA	V <sub>I</sub> =0V 【Note6】
Input current (High)		I <sub>OH1</sub>	-	-	1.0	μA	V <sub>I</sub> =Vcc 【Note7】
		I <sub>OH2</sub>			300	μA	V <sub>I</sub> =Vcc 【Note8】
		I <sub>OH3</sub>	-	-	800	μA	V <sub>I</sub> =Vcc 【Note9】

#### 【NOTE 1】

Vcc-turn-on conditions

- 0 < T1 15 ms
- 0 < T2 10 ms
- 0 < T3 100 ms
- 0 < T4 1 s
- T5 > 200 ms

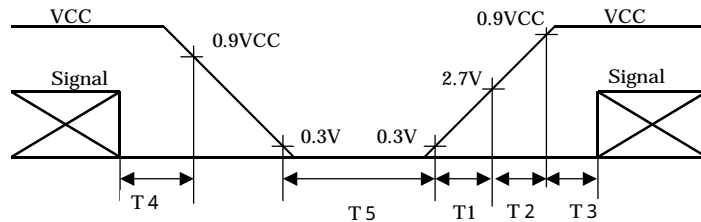

Vcc-dip conditions

- 1) 2.5V < Vcc
  - td < 10ms
  - 2) Vcc < 2.5V
- Vcc-dip condition should also follow the Vcc-turn-on conditions.

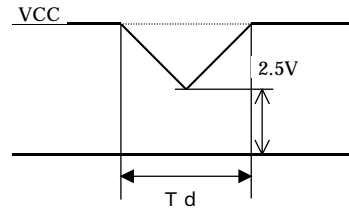

【Note2】 Typical current situation : 16-gray-bar pattern.

480 line mode/Vcc=+3.3V/ + 5.0V

【Note3】 CK, R0~R5, G0~G5, B0~B5, Hsync, Vsync, ENAB, R/L, U/D

【Note4】 CK, R0~R5, G0~G5, B0~B5, Hsync, Vsync,

【Note5】 U/D, ENAB

【Note6】 R/L

【Note7】 CK, R0~R5, G0~G5, B0~B5, Hsnc, Vsync, R/L

【Note8】 ENAB

【Note9】 U/D

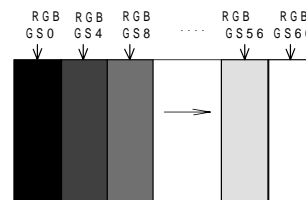

## 6-2. Backlight driving

The backlight system is an edge-lighting type with single CCFT (Cold Cathode Fluorescent Tube).

The characteristics of single lamp are shown in the following table.

(It is usually required to measure under the following condition.

condition:  $I_L=6.0\text{mA}$ ,  $T_a=25 \pm 2$ ,  $f_L=60\text{kHz}$ .)

Parameter	Symbol	Min.	Typ.	Max.	Unit	Remark
Lamp current	$I_L$	2.0	6.0	6.5	mArms	【Note1】
Lamp power consumption	$P_L$	-	(3.0)	-	W	【Note2】
Lamp frequency	$f_L$	20	35	60	KHz	【Note3】
Kick-off voltage	$V_s$	-	-	(950)	Vrms	$T_a=25$ 【Note4】
		-	-	(1400)	Vrms	$T_a=0$ 【Note4】
		-	-	(1500)	Vrms	$T_a=-10$ 【Note4】

【Note1】 Lamp current is measured with current meter for high frequency as shown below.

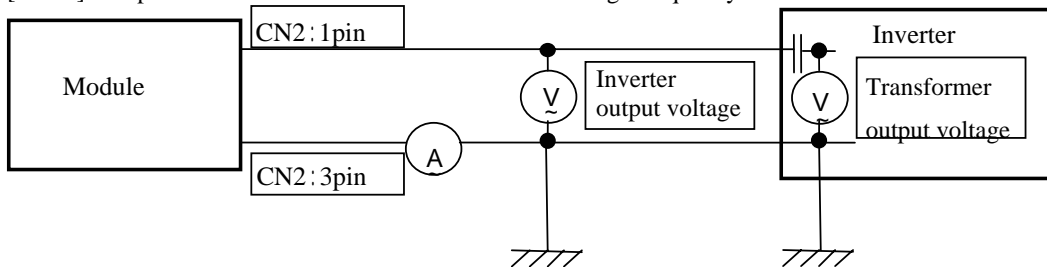

【Note2】 Referential data per one CCFT by calculation. ( $I_L \times V_L$ )

The data do not include loss at inverter. ( $I_L=6.0\text{mArms}$ )

【Note3】 Lamp frequency may produce interference with horizontal synchronous frequency, and this may cause beat on the display. Therefore lamp frequency shall be detached as much as possible from the horizontal synchronous frequency and from the harmonics of horizontal synchronous to avoid interference.

【Note4】 The open output voltage of the inverter shall be maintained for more than 1s; otherwise the lamp may not be turned on.

【Note5】 lamp is an article of consumption. Lamp life time is 50,000 hours (reference value) on condition of the following, but this value is not guaranteed.

When lamp (the long side of LCD module) is placed horizontally (landscape position), lamp life time is defined that it applied either or under this condition.

(Continuous turning on at  $T_a=25^\circ\text{C}$ ,  $I_L=6.0\text{mA rms}$ .)

Brightness becomes 50% of the original value under standard condition.

Kick-off voltage at  $T_a=-10^\circ\text{C}$  exceeds maximum value.

(Lamp lifetime may vary if lamp is in portrait position due to the change of mercury density inside the lamp.)

In case of operating under lower temp environment, the lamp exhaustion is accelerated and the brightness becomes lower.

(Continuous operating under lower temp condition for around 1 month may reduce the brightness to half of the original brightness.)

In case of such usage under lower temp environment, periodical lamp exchange is recommended.

【Note6】 The performance of the backlight, for example life time or brightness, is much influenced by the characteristics of the DC-AC inverter for the lamp. When you design or order the inverter, please make sure that a poor lighting caused by the mismatch of the backlight and the inverter (miss-lighting, flicker, etc.) never occur. when you confirm it, the module should be operated in the same condition as it is installed in your instrument.

Be sure to use a back light power supply with the safety protection circuit such as the detection circuit for the excess voltage, excess current and or electric discharge waveform.

Be sure to use the detect circuit by which one side of the CCFT lamps can be controlled independently.

Otherwise, when one side of the CCFT is open, the excess current may possibly be applied to the other side of the lamp.

【Note7】 Under the environment of 10lx or less, miss-lighting delay may occur.



## 7. Timing Characteristics of input signals

Timing diagrams of input signal are shown in Fig.2 - ~ .

### 7-1. Timing characteristics

Parameter	Symbol	Mode	Min.	Typ.	Max.	Unit	Remark	
Clock	Frequency	1/Tc	-	25.18	28.33	MHz		
	High time	Tch	5	-	-	ns		
	Low time	Tcl	10	-	-	ns		
Data	Setup time	Tds	5	-	-	ns		
	Hold time	Tdh	10	-	-	ns		
Horizontal sync. signal	Cycle	TH	30.00	31.78	-	μs		
		"	750	800	900	clock		
	Pulse width	THp	2	96	200	clock		
Vertical sync. signal	Cycle	TV	480	515	525	560	line	
		"	400	446	449	480	line	
		"	350	447	449	510	line	
	Pulsewidth	TVp	all	1	-	34	line	
Horizontal display period	THd	"	640	640	640	clock		
Hsync-Clock Phase difference	THc	"	10	-	Tc-10	ns		
Hsync-Vsync Phase difference	TVh	"	0	-	TH-THp	clock		

Note) In case of lower frequency, the deterioration of display quality, flicker etc., may be occurred.

### 7-2. Horizontal display position

The horizontal display position is determined by the rising edge of ENAB signal.

Parameter	symbol	Min.	Typ.	Max.	Unit	Remark
Enable signal	Setup time	Tes	5	-	Tc-10	ns
	Pulse width	Tep	2	640	640	clock
Hsync-Enable signal phase difference	THE	44	-	TH-664	clock	

Note) When ENAB is fixed "Low", the display starts from the data of C104(clock) as shown in Fig.2- ~ .

When the phase difference is below 104 clocks, keep the "High" level of ENAB is signal longer than 104-The clocks. If it will not be kept, the display starts from the data of C104(clock).

### 7-3. Vertical display position

The vertical display position is automatically centered in the active area at each mode of VGA 480, 400, and 350-line mode, when each mode is selected depending on the polarity of the synchronous signals described in 4-1(Note1).

In 400- and 350-line mode, when vertical synchronous signal TV is timing other than the above-mentioned typical value, a screen display position may shift.

In 400- and 350-line mode, the data in the vertical data invalid period is also displayed, so, inputting all data "0" is recommended during vertical data invalid period.

ENAB signal has no relation to the vertical display position.

Mode	V-data start(TVs)	V-data period(TVd)	V-display start(TVn)	V-display period	Unit	Remark
480	34	480	34	480	line	
400	34	400	443-TV	480	line	
350	61	350	445-TV	480	line	

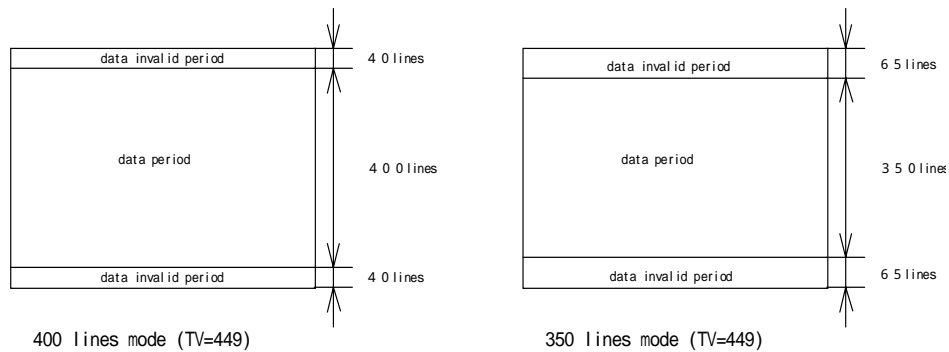

#### 7-4. Input Data Signals and Display Position on the screen

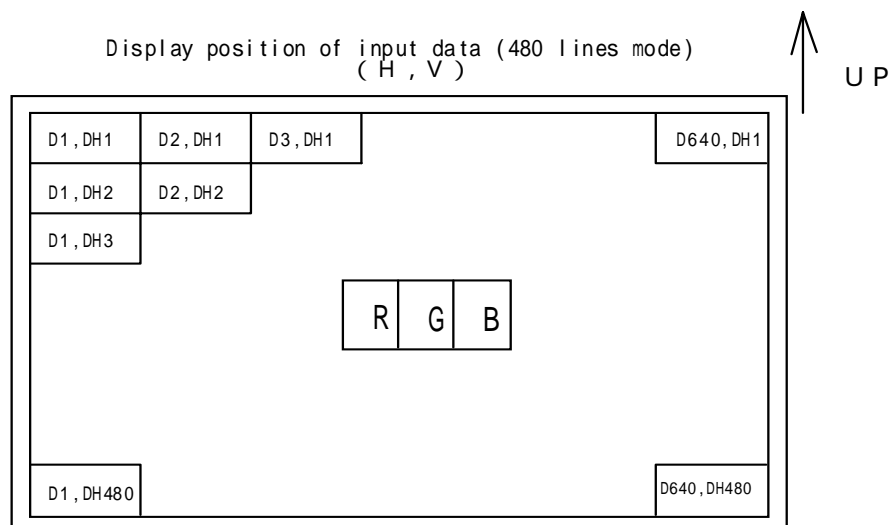

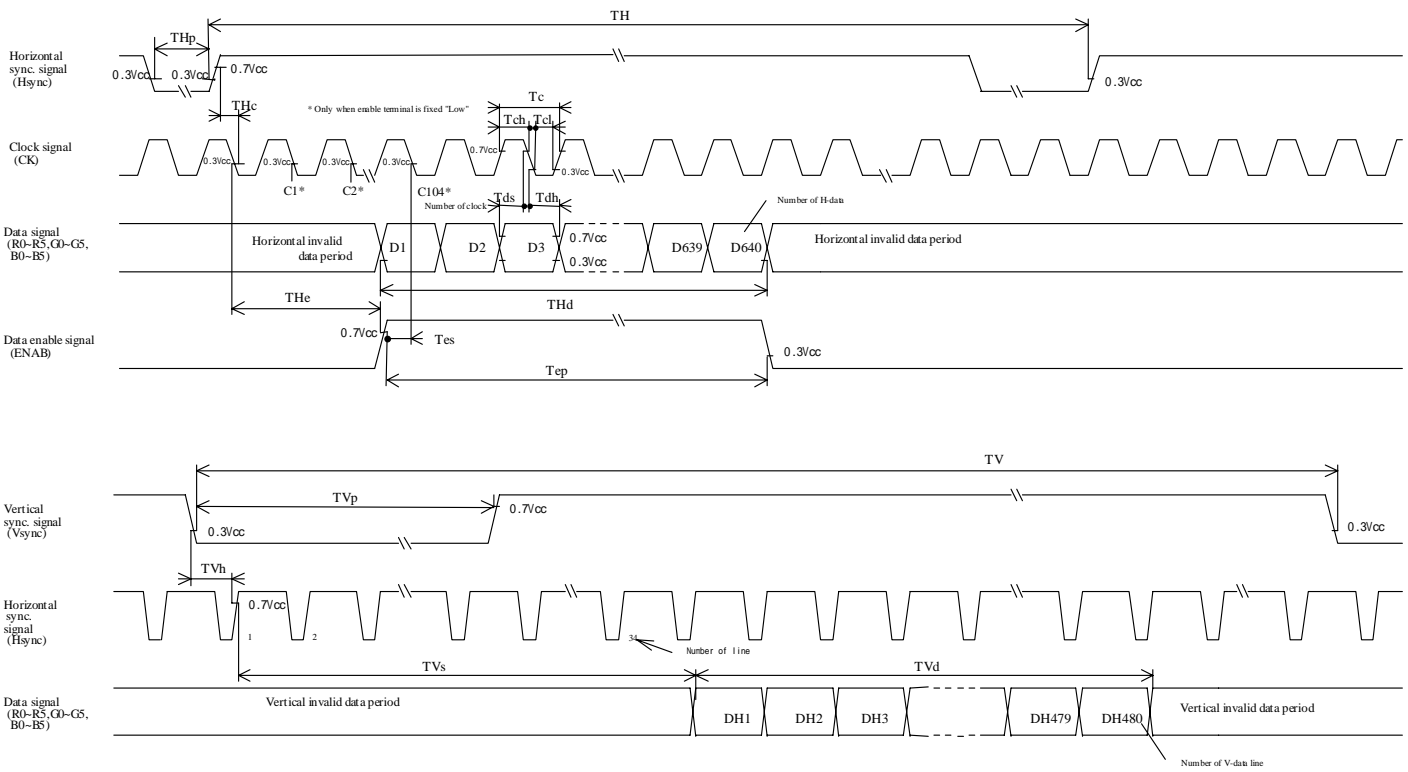

Fig 2-1 Input signal waveforms (480 line mode)

**DATA MODUL**

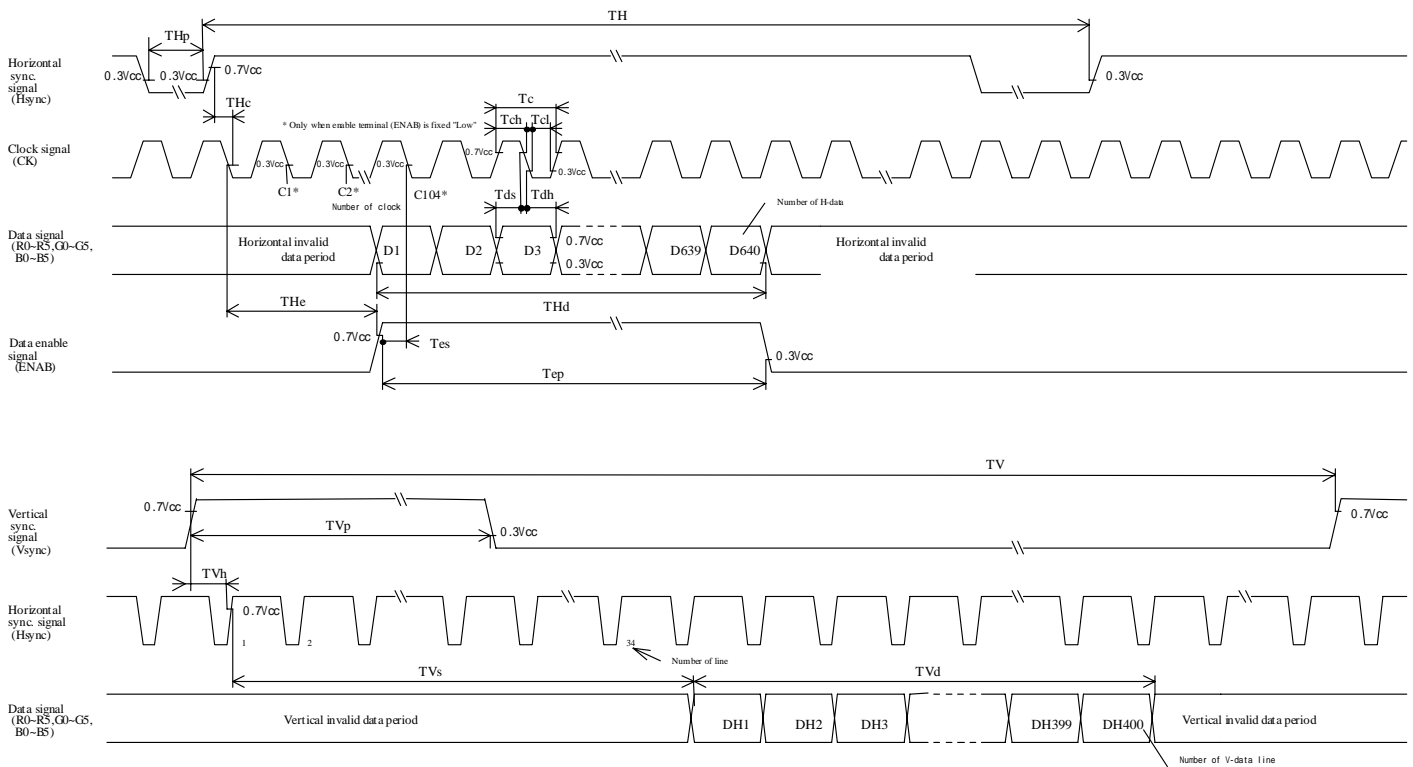

Fig.2-2 Input signal waveforms (400 line mode)

**DATA MODUL**

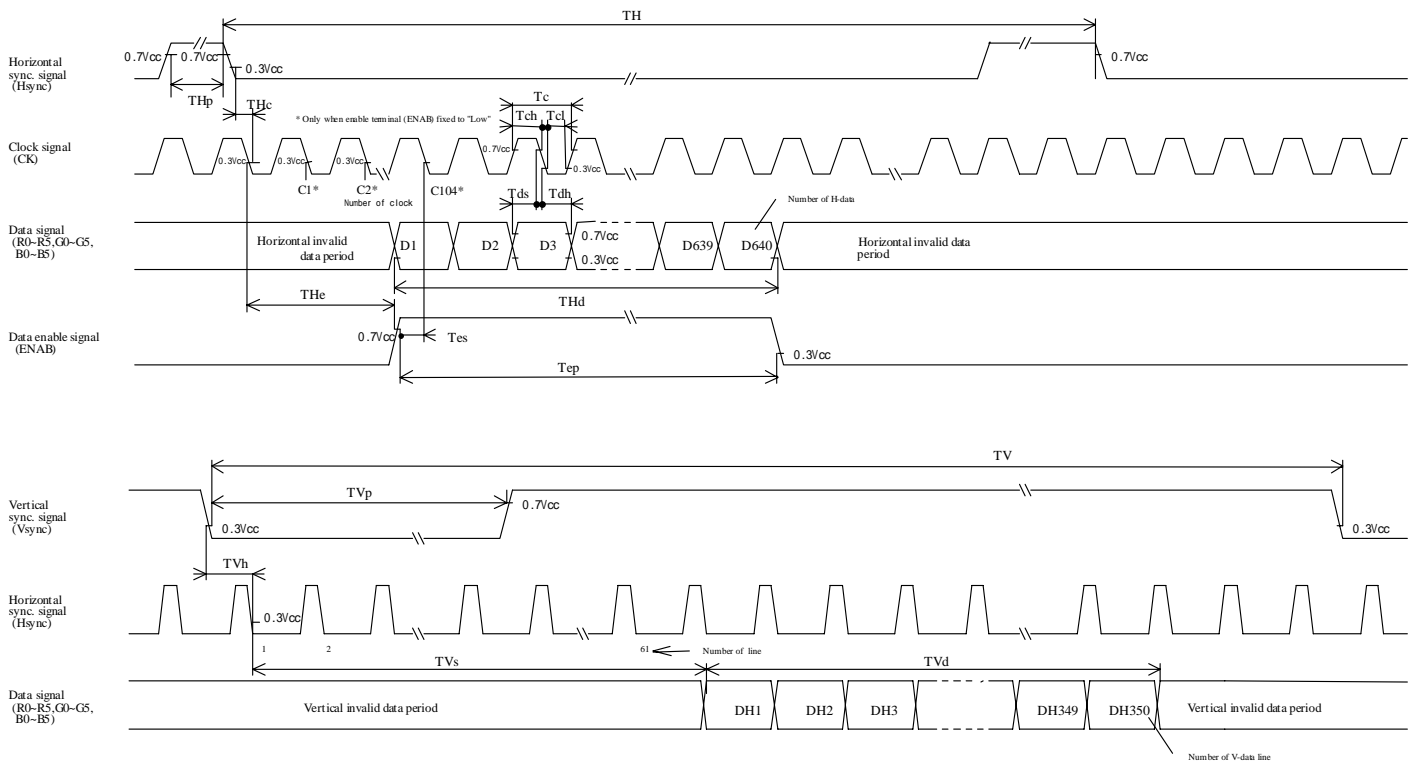

Fig.2-3 Input signal waveforms (350 line mode)

**DATA MODUL**

## 8. Input Signals, Basic Display Colors and Gray Scale of Each Color

	Colors & Gray scale	Data signal																		
		Gray Scale	R0	R1	R2	R3	R4	R5	G0	G1	G2	G3	G4	G5	B0	B1	B2	B3	B4	B5
Basic Color	Black	-	0	0	0	0	0	0	0	0	0	0	0	0	0	0	0	0	0	0
	Blue	-	0	0	0	0	0	0	0	0	0	0	0	0	1	1	1	1	1	1
	Green	-	0	0	0	0	0	0	1	1	1	1	1	1	0	0	0	0	0	0
	Cyan	-	0	0	0	0	0	0	1	1	1	1	1	1	1	1	1	1	1	1
	Red	-	1	1	1	1	1	1	0	0	0	0	0	0	0	0	0	0	0	0
	Magenta	-	1	1	1	1	1	1	0	0	0	0	0	0	1	1	1	1	1	1
	Yellow	-	1	1	1	1	1	1	1	1	1	1	1	1	0	0	0	0	0	0
	White	-	1	1	1	1	1	1	1	1	1	1	1	1	1	1	1	1	1	1
Gray Scale of Red	Black	GS0	0	0	0	0	0	0	0	0	0	0	0	0	0	0	0	0	0	0
	↑	GS1	1	0	0	0	0	0	0	0	0	0	0	0	0	0	0	0	0	0
	Darker	GS2	0	1	0	0	0	0	0	0	0	0	0	0	0	0	0	0	0	0
	↑	↓			↓					↓					↓					
	↓	↓			↓					↓					↓					
	Brighter	GS61	1	0	1	1	1	1	0	0	0	0	0	0	0	0	0	0	0	0
	↓	GS62	0	1	1	1	1	1	0	0	0	0	0	0	0	0	0	0	0	0
	Red	GS63	1	1	1	1	1	1	0	0	0	0	0	0	0	0	0	0	0	0
Gray Scale of Green	Black	GS0	0	0	0	0	0	0	0	0	0	0	0	0	0	0	0	0	0	0
	↑	GS1	0	0	0	0	0	0	1	0	0	0	0	0	0	0	0	0	0	0
	Darker	GS2	0	0	0	0	0	0	0	1	0	0	0	0	0	0	0	0	0	0
	↑	↓			↓					↓					↓					
	↓	↓			↓					↓					↓					
	Brighter	GS61	0	0	0	0	0	0	1	0	1	1	1	1	0	0	0	0	0	0
	↓	GS62	0	0	0	0	0	0	0	1	1	1	1	1	0	0	0	0	0	0
	Green	GS63	0	0	0	0	0	0	1	1	1	1	1	1	0	0	0	0	0	0
Gray Scale of Blue	Black	GS0	0	0	0	0	0	0	0	0	0	0	0	0	0	0	0	0	0	0
	↑	GS1	0	0	0	0	0	0	0	0	0	0	0	0	1	0	0	0	0	0
	Darker	GS2	0	0	0	0	0	0	0	0	0	0	0	0	0	1	0	0	0	0
	↑	↓			↓					↓					↓					
	↓	↓			↓					↓					↓					
	Brighter	GS61	0	0	0	0	0	0	0	0	0	0	0	0	1	0	1	1	1	1
	↓	GS62	0	0	0	0	0	0	0	0	0	0	0	0	0	1	1	1	1	1
	Blue	GS63	0	0	0	0	0	0	0	0	0	0	0	0	1	1	1	1	1	1

0 :Low level voltage, 1 : High level voltage

Each basic color can be displayed in 64 gray scales from 6 bit data signals. According to the combination of total 18 bit data signals, the 262,144-color display can be achieved on the screen.

## 9. Optical Characteristics

Ta=25 , Vcc=+5V

Parameter		Symbol	Condition	Min	Typ	Max	Unit	Remark
Viewing Angle Range	Horizontal	21, 22	C R > 1 0	60	70	-	Deg.	【Note1,4】
	Vertical	11		35	40	-	Deg.	
		12		55	70	-	Deg.	
Contrast ratio		C R	= 0 °	150	-	-	-	【Note2,4】
			Optimum Viewing Angle	-	300	-	-	
Response Time	Rise	r	= 0 °	-	10	-	ms	【Note3,4】
	Decay	d		-	25	-	ms	
Chromaticity of White		x	= 0 °	-	0.313	-	-	【Note4】 I <sub>L</sub> =6.0mA f=60kHz
		y		-	0.329	-	-	
Luminance of white		Y <sub>L</sub>		(160)	(200)	-	cd/m <sup>2</sup>	
White Uniformity		w		-	-	1.45	-	【Note5】
Viewing Angle range as a Brightness Definition	Horizontal	21, 22	50% of the maximum brightness	-	(45)	-	Deg.	【Note1】
	Vertical	11		-	(35)	-	Deg.	
		12		-	(30)	-	Deg.	

The measurement shall be executed 30 minutes after lighting at rating. (condition:I<sub>L</sub>=6.0mA, FL=60KHz)

The optical characteristics shall be measured in a dark room or equivalent state with the method shown in Fig.3 below.

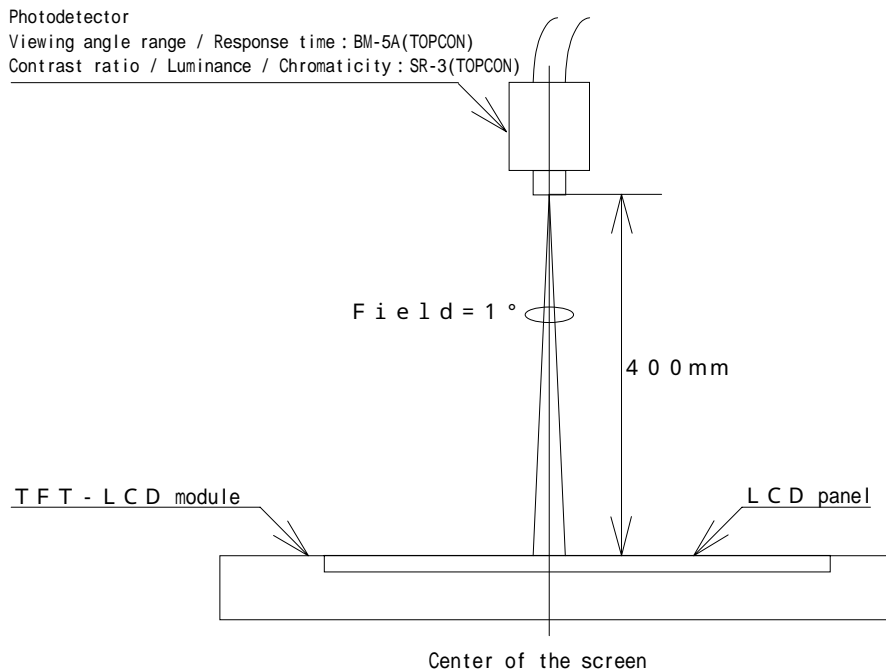
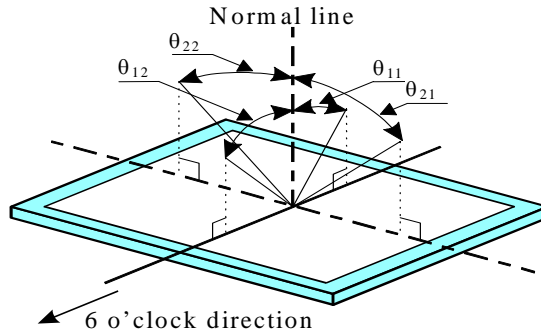

Fig.3 Optical characteristics measurement method

【Note1】 Definitions of viewing angle range:



【Note2】 Definition of contrast ratio:

The contrast ratio is defined as the following.

$$\text{Contrast Ratio (CR)} = \frac{\text{Luminance (brightness) with all pixels white}}{\text{Luminance (brightness) with all pixels black}}$$

【Note3】 Definition of response time:

The response time is defined as the following figure and shall be measured by switching the input signal for "black" and "white" .

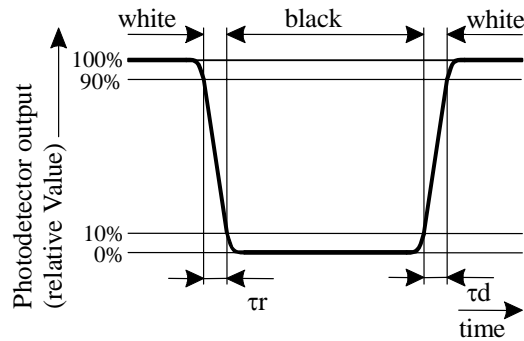

【Note4】 This shall be measured at center of the screen.

【Note5】 Definition of white uniformity:

White uniformity is defined as the following with five measurements (A ~ E).

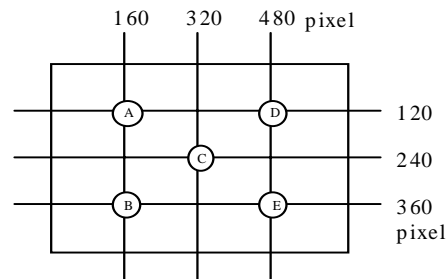

$$w = \frac{\text{Maximum Luminance of five points (brightness)}}{\text{Minimum Luminance of five points (brightness)}}$$



#### 10. Display Quality

The display quality of the color TFT-LCD module shall be in compliance with the Incoming Inspection Standard.

#### 11 . Handling Precautions

- a) Be sure to turn off the power supply when inserting or disconnecting the cable.
- b) Be sure to design the cabinet so that the module can be installed without any extra stress such as warp or twist.
- c) Since the front polarizer is easily damaged, pay attention not to scratch it.
- d) Wipe off water drop immediately. Long contact with water may cause discoloration or spots.
- e) When the panel surface is soiled, wipe it with absorbent cotton or other soft cloth.
- f) Since the panel is made of glass, it may break or crack if dropped or bumped on hard surface.  
Handle with care.
- g) Since CMOS LSI is used in this module, take care of static electricity and injure the human earth when handling. Observe all other precautionary requirements in handling electric components.
- h) Since there is a circuit board in the module back, stress is not added at the time of a design assembly. Please make it like. If stress is added, there is a possibility that circuit parts may be damaged.
- i) Protection film is attached to the module surface to prevent it from being scratched .  
Peel the film off slowly, just before the use, with strict attention to electrostatic charges.  
Blow off 'dust' on the polarizer by using an ionized nitrogen.
- j) The polarizer surface on the panel is treated with Anti-Glare for low reflection. In case of attaching protective board over the LCD, be careful about the optical interface fringe etc. which degrades display quality.
- k) Do not expose the LCD panel to direct sunlight. Lightproof shade etc. should be attached when LCD panel is used under such environment. If a light strong against a LCD panel is irradiated, it may lead to degradation of the panel characteristic and display grace may get worse.
- l) Connect GND to 4 place of mounting holes to stabilize against EMI and external noise.
- m) There are high voltage portions on the backlight and very dangerous. Careless touch may lead to electrical shock. When exchange lamps or service, turn off the power without tail.
- n) When handling LCD modules and assembling them into cabinets, please be noted that long-term storage in the environment of oxidization or deoxidization gas, and the use of such materials as reagent, solvent, adhesive, resin, etc. which generate these gasses, may cause corrosion, discoloration, degradation of display grace, and abnormalities of operation.
- o) Cold cathode fluorescent lamp in LCD panel contains a small amount of mercury, please follow local ordinances or regulations for disposal.
- p) Be careful of a back light lead not to pull by force at the time of the wiring to an inverter, or line processing.
- q) When install LCD modules in the cabinet, recommended torque value is "0.294 ± 0.02N· m (3.0 ± 0.2kgf· cm)".  
Be sure to confirm it in the same condition as it is installed in your instrument.
- r) Liquid crystal contained in the panel may leak if the LCD is broken. Rinse it as soon as possible if it gets inside your eye or mouth by mistake.
- s) Notice:Never dismantle the module , because it will cause failure.
- t) Be careful when using it for long time with fixed pattern display as it may cause afterimage.
- u) Adjusting volume have been set optimally before shipment, so do not change any adjusted value.  
If adjusted value is changed, the specification may not be satisfied.
- v) If a minute particle enters in the module and adheres to an optical material, it may cause display non-uniformity issue, etc. Therefore, fine-pitch filters have to be installed to cooling and inhalation hole if you intend to install a fan.
- w) The lamp used for this product is very sensitive to the temperature. Luminance decreases rapidly when it is used for a long time or repeatedly under the environment of the low temperature or the module is being cooled. Please avoid the continuous or repeatedly use of it such an environment.  
It may decrease up to 50% of the initial luminance in about one month under the low temperature environment. Please consult our company when it is used under the environment like above mentioned.

## 12. Packing form

Product countries / Areas	JAPAN, TAIWAN, CHINA
Piling number of cartons	(TBD)
Packing quantity in one carton	(TBD)
Carton size [mm]	(TBD)
Total mass of one carton filled with full modules	(TBD)
Packing form is shown	Fig.4(TBD)

## 13 . Reliability test items

No.	Test item	Conditions	Remark
1	High temperature storage test	Ta=70 240h	Panel surface
2	Low temperature storage test	Ta= -30 240h	
3	High temperature & high humidity operation test	Ta=40 ; 95%RH 240h (No condensation)	
4	High temperature operation test	Ta=65 240h	Panel surface
5	Low temperature operation test	Ta= -10 240h	
6	Vibration test (non- operating)	Frequency: 10 ~ 57Hz/Vibration width (one side):0.075mm : 58 ~ 500Hz/Gravity:9.8m/s <sup>2</sup> Sweep time : 11 minutes Test period : 3 hours (1 hour for each direction of X,Y,Z)	
7	Shock test (non- operating)	Max. gravity : 490m/s <sup>2</sup> Pulse width : 11ms, half sine wave Direction : ± X, ± Y, ± Z once for each direction.	
8	ESD test	Contact discharge (150pF 330 ) non-operating = ± 10kV, operating = ± 8kV Atmospheric discharge (150pF 330 ) non-operating = ± 20kV, operating = ± 15kV	
9	EMI	Measurement in 10m site Display position on the screen = "H"(full-screen) GND to 4 place = un-connect, Vcc / Vsignal = typ.	VCCI (Class B)

## [Result Evaluation Criteria]

Under the display quality test conditions with normal operation state, these shall be no change which may affect practical display function. (normal operation state : Temperature:15 ~ 35 , Humidity:45 ~ 75%, Atmospheric pressure:86 ~ 106kpa)

## 14. Others

### 14-1 Lot No. Label:

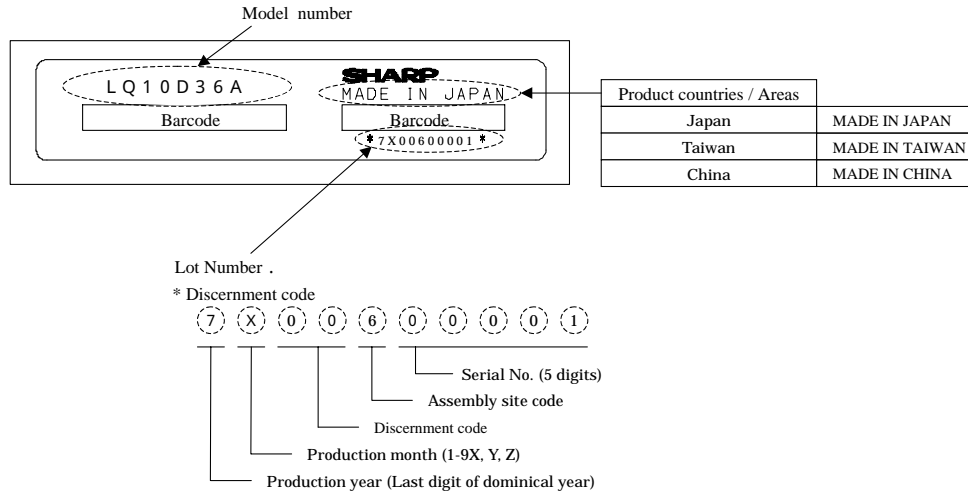

### 14-2 Packing box Label:

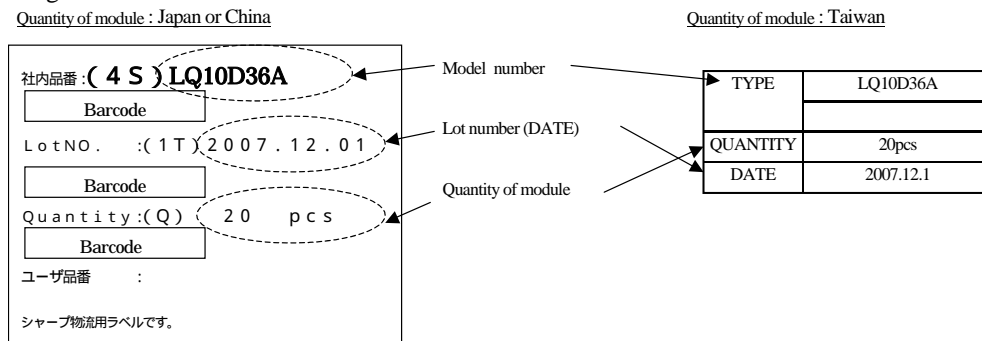

The following figure is written to the container box RoHS Compliance corresponded.

Internal Use Only  
R . C .

R.C. (RoHS Compliance) means these parts have corresponded with the RoHS directive.

14-3 If any problem occurs in relation to the description of this technical literature, it shall be resolved through discussion with spirit of cooperation.

# DATA MODUL

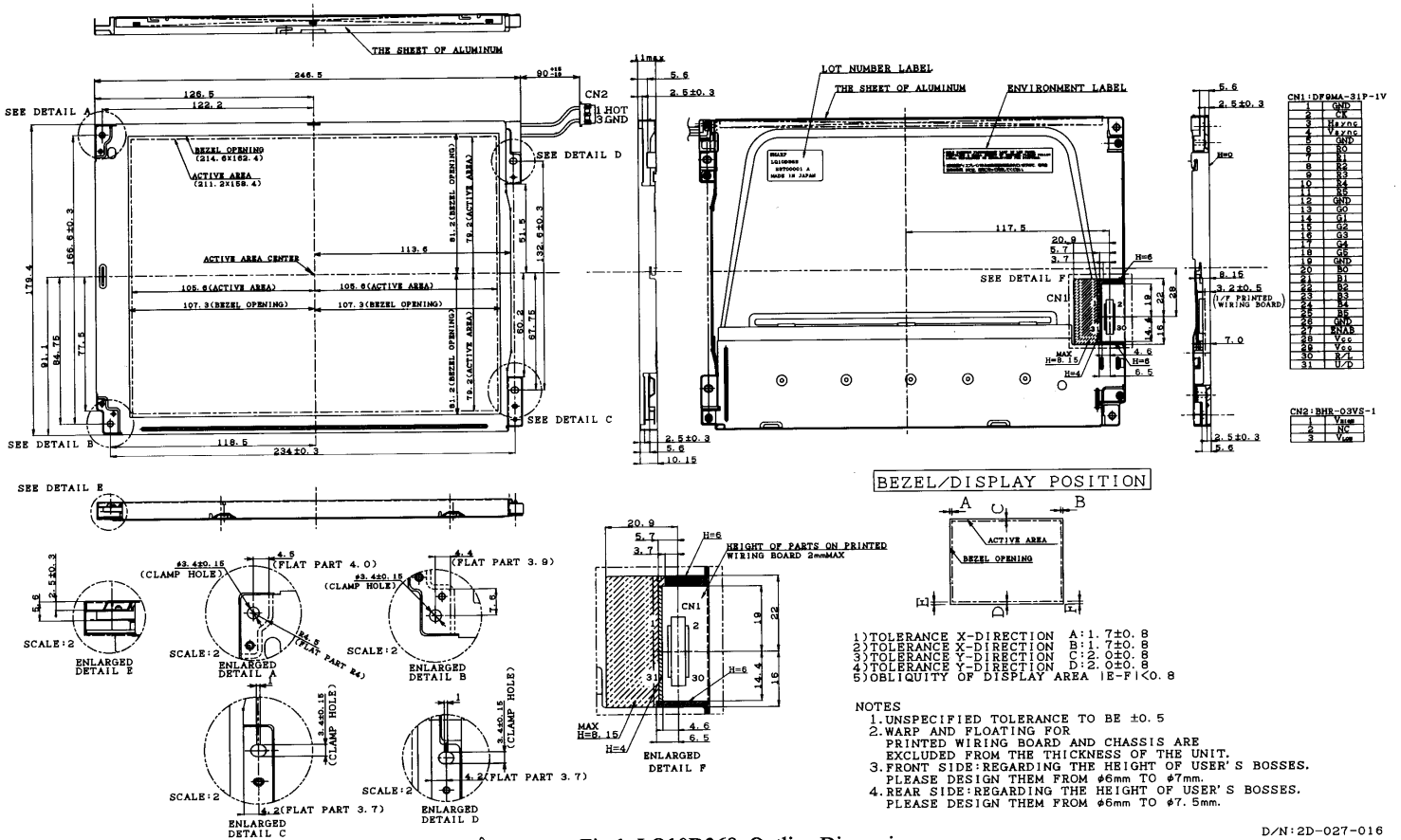

(Reference) Fig.1 LQ10D368 Outline Dimensions

D/N:2D-027-016



Data Modul Headquarters Munich  
Landsberger-Str. 322  
D-80687 Munich - Germany  
Tel.: +49-89-56017-0



Sales Office Duesseldorf  
Fritz-Vomfelde-Str. 8  
D-40547 Duesseldorf - Germany  
Tel.: +49-211-52709-0



Sales Office Hamburg  
Borsteler Chaussee 51  
D-22453 Hamburg - Germany  
Tel.: +49-40-42947377 - 0



Sales Office Stuttgart  
Friedrich-List-Str. 42  
D-70771 Leinfelden-Echterdingen  
Germany  
Tel.: +49-711-782385-0



Data Modul France, S.A.R.L.  
Bat B - Hall 204  
1-3 Rue des Campanules  
77185 Lognes - France  
Tel.: +33-1-60378100



Data Modul Italia, S.r.l.  
Regus Center Senigallia  
Via Senigallia 18/2  
20161 Milano - Italy  
Tel.: +39-02-64672-509

Data Modul Iberia, S.L.  
c/ Adolfo Pérez Esquivel 3  
Edificio Las Americas III Oficiana 40  
28230 Parque Empresarial  
Madrid Las Rozas - Spain  
Tel.: +34-916 366 458

Data Modul Ltd. / UK  
3 Brindley Place  
Birmingham B 12JB  
United Kingdom  
Tel.: +44-121-698-8641

Data Modul Inc. / USA  
1767-46 Veterans Memorial Highway  
Islandia NY 11749  
USA  
Tel.: +1-877-951-0800

[www.data-modul.com](http://www.data-modul.com)  
[display@data-modul.com](mailto:display@data-modul.com)