

HOA2862

Transmissive Sensor

FEATURES

- Choice of phototransistor or photodarlington output
- Wide operating temperature range (-55°C to +100°C)
- Accurate position sensing
- 0.100 in. (2.54 mm) slot width

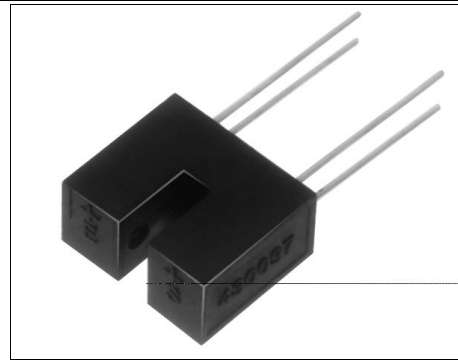

INFRA-77.TIF

DESCRIPTION

The HOA2862 series consists of an infrared emitting diode facing an NPN silicon phototransistor (HOA2862-001, -002) or photodarlington (HOA2862-003) encased in a black thermoplastic housing. Detector switching takes place whenever an opaque object passes through the slot between emitter and detector. The HOA2862 series employs metal can packaged components and has a 0.025 in. (.635 mm) x 0.040 in. (1.02 mm) vertical aperture in front of the detector. The narrow detector aperture is ideal for use in applications in which the maximum rejection of ambient light is important. For additional component information see SE1450, SD1440, and SD1410.

Housing material is polyester. Housings are soluble in chlorinated hydrocarbons and ketones. Recommended cleaning agents are methanol and isopropanol.

OUTLINE DIMENSIONS in inches (mm)

Tolerance 3 plc decimals ±0.010(0.25)
2 plc decimals ±0.020(0.51)

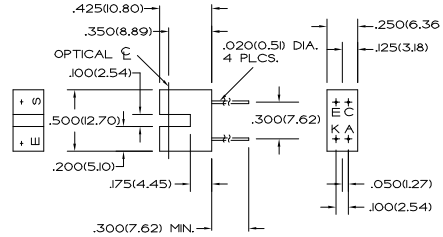

DIM_058.cdr

HOA2862

Transmissive Sensor

ELECTRICAL CHARACTERISTICS (25°C unless otherwise noted)

PARAMETER	SYMBOL	MIN	TYP	MAX	UNITS	TEST CONDITIONS
IR EMITTER						
Forward Voltage	V_F			1.6	V	$I_F=20$ mA
Reverse Leakage Current	I_R			10	μ A	$V_R=3$ V
DETECTOR						
Collector-Emitter Breakdown Voltage	$V_{(BR)CEO}$				V	$I_C=100$ μ A
HOA2862-001, -002		30				
HOA2862-003		15				
Emitter-Collector Breakdown Voltage	$V_{(BR)ECO}$	5.0			V	$I_E=100$ μ A
Collector Dark Current	I_{CEO}				nA	$V_{CE}=10$ V
HOA2862-001, -002				100		$I_F=0$
HOA2862-003				250		
COUPLED CHARACTERISTICS						
On-State Collector Current	$I_{C(ON)}$				mA	$V_{CE}=5$ V
HOA2862-001		0.2				$I_F=20$ mA
HOA2862-002		1.8				
HOA2862-003		4.0				
Collector-Emitter Saturation Voltage	$V_{CE(SAT)}$				V	$I_F=20$ mA
HOA2862-001				0.4		$I_C=25$ μ A
HOA2862-002				0.4		$I_C=75$ μ A
HOA2862-003				1.1		$I_C=500$ μ A
Rise And Fall Time	t_r, t_f				μ s	$V_{CC}=5$ V, $I_C=1$ mA
HOA2862-001, -002			15			$R_L=1000$ Ω
HOA2862-003			75			$R_L=100$ Ω

ABSOLUTE MAXIMUM RATINGS

(25°C Free-Air Temperature unless otherwise noted)

Operating Temperature Range -55°C to 100°C

Storage Temperature Range -55°C to 125°C

Soldering Temperature (10 sec) 260°C

IR EMITTER

Power Dissipation 75 mW ⁽¹⁾

Reverse Voltage 3 V

Continuous Forward Current 50 mA

DETECTOR

Collector-Emitter Voltage **TRANS.** 30 V **DARLINGTON** 15 V

Emitter-Collector Voltage 5 V 5 V

Power Dissipation 75 mW ⁽¹⁾ 75 mW ⁽¹⁾

Collector DC Current 30 mA 30 mA

SCHEMATIC

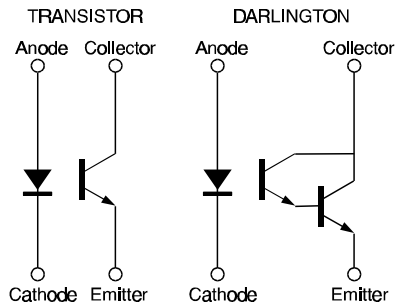

Honeywell reserves the right to make changes in order to improve design and supply the best products possible.

Honeywell

347

HOA2862

Transmissive Sensor

Fig. 1 IRED Forward Bias Characteristics

gra_092.ds4

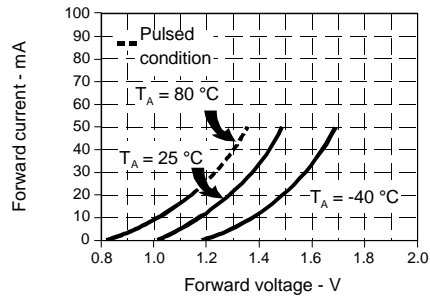

Fig. 2 Non-Saturated Switching Time vs Load Resistance

gra_096.ds4

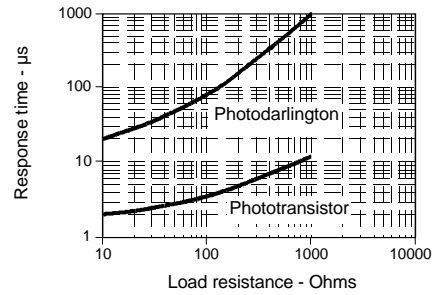

Fig. 3 Dark Current vs Temperature

gra_303.cdr

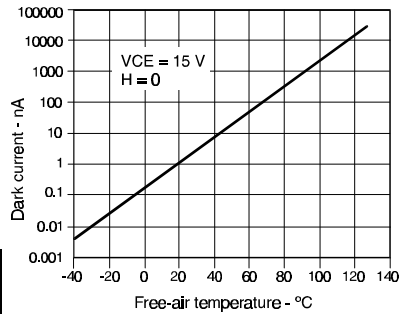
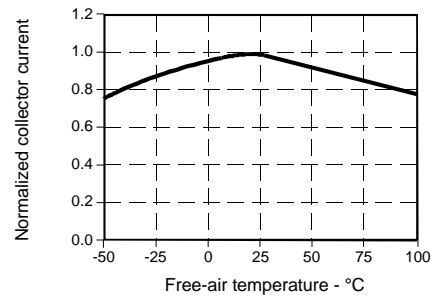

Fig. 4 Collector Current vs Ambient Temperature

gra_095.ds4



All Performance Curves Show Typical Values

HOA2862

Transmissive Sensor



Honeywell reserves the right to make changes in order to improve design and supply the best products possible.

Honeywell

349