

DESCRIPTION

RangeMAX Wide Range Dimming, Single Output Inverter. The LXMG1612-05-xx series of Direct Drive™ CCFL (Cold Cathode Fluorescent Lamp) Inverter Modules are specifically designed for driving LCD backlight lamps.

RangeMAX Digital Dimming Technique. Digital Dimming provides flicker-free brightness control in any wide-range dimming application.

The modules are equipped with a dimming input that permits brightness control from an external potentiometer, DC voltage source, or PWM signal. The resultant "burst drive" that energizes the lamp was designed specifically to ensure that no premature lamp degradation occurs.

IMPORTANT: For the most current data, consult MICROSEMI's website: <http://www.microsemi.com>
Protected by U.S. Patents: 5,923,129; 5,930,121; Patents Pending

Input Voltage Range: The modules convert DC voltage from the system battery or AC adapter directly to high-frequency, high-voltage waves required to ignite and operate CCFL lamps. A 12V input inverter is also available (LXMG1612-12-xx)

Direct Drive Technology: The module design is based on a new Direct Drive topology, which provides a number of cost and performance advantages.

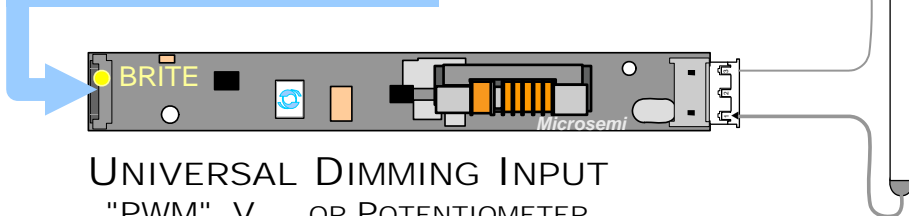
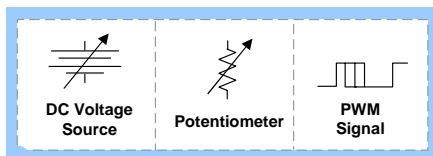
Additional Feature: Other benefits of this new topology are fixed-frequency operation and secondary-side strike-voltage regulation and all LXMG1612-05-xx modules feature both open and shorted lamp protection.

KEY FEATURES

- RangeMAX Wide Range Dimming
- Single 5V Input Voltage
- Fully Integrated Direct Drive And Dimming Control
- Single Sided PCB Layout
- Easy To Use Brightness Control
- MicroAmp SLEEP Mode
- Output Short-Circuit Protection And Automatic Strike-Voltage Regulation
- Fixed Frequency Operation
- UL 60950 E175910
- RoHS Compliant

APPLICATIONS

- Notebook And Sub-Notebook Computers
- Portable Instrumentation
- Desktop Displays
- Low Ambient Light Conditions (i.e. Aircraft Cabins, Automobile)

PRODUCT HIGHLIGHT


UNIVERSAL DIMMING INPUT
"PWM", V_{DC} , OR POTENTIOMETER

BENEFITS

- Smooth, Flicker Free 1-100% Full-Range Brightness Control Gives Your Product A High Quality Image
- Output Open Circuit Voltage Regulation Minimizes Corona Discharge For Long Life And High Reliability
- Power Efficient. "Low Brightness" Capability Allows For Advanced Power Management

PACKAGE ORDER INFO

PART NUMBER	OUTPUT CONNECTOR	INVERTER MATES DIRECTLY TO PANEL CONNECTORS
LXMG1612-05-01	JST SM02(8.0)B-BHS-1-TB(LF)(SN) or Yeon Ho 20015WR-05A00	BHR-03VS-1
LXMG1612-05-02	JST SM02B-BHSS-1-TB(LF)(SN) or Yeon Ho 35001WR-02A00	BHRS-02VS-1
LXMG1612-05-03	Honda QZ-19-A3MYL #02	Honda QZ-19-3F01

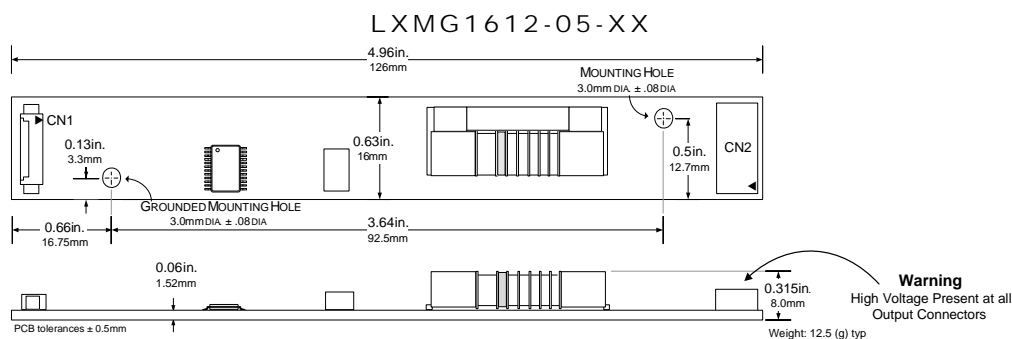
ABSOLUTE MAXIMUM RATINGS (NOTE 1)

Input Signal Voltage (V_{IN1}).....	-0.3V to 6.5V
Output Voltage, no load.....	Internally Limited to $1800V_{RMS}$
Output Current.....	$8.0mA_{RMS}$ (Internally Limited)
Output Power.....	6.0W
Input Signal Voltage (BRITE Input).....	-0.3V to $V_{IN1}+0.3V$
Input Signal Voltage (\overline{SLEEP} , V_{SYNC} Inputs).....	-0.3V to $V_{IN1}+0.3V$
Ambient Operating Temperature, zero airflow.....	$0^{\circ}C$ to $70^{\circ}C$
Storage Temperature Range.....	$-40^{\circ}C$ to $85^{\circ}C$

Note 1: Exceeding these ratings could cause damage to the device. All voltages are with respect to Ground. Currents are positive into, negative out of specified terminal.

FUNCTIONAL PIN DESCRIPTION

CONN	PIN	DESCRIPTION
CN1 (Molex 53261-0871) Mates with 51021-0800 housing, 50079-8100 pins		
CN1-1	V_{IN1}	Main Input Power Supply ($4.5V \leq V_{IN1} \leq 5.5V$)
CN1-2		
CN1-3	GND	Power Supply Return
CN1-4		
CN1-5	\overline{SLEEP}	ON/OFF Control. ($2.1V < \overline{SLEEP} < V_{IN1} = ON$, $0V < \overline{SLEEP} < 0.8V = OFF$, \overline{SLEEP} Floating = OFF)
CN1-6	BRITE	Brightness Control ($0.0V$ to $2.5V_{DC}$). $2.5V_{DC}$ gives maximum lamp current.
CN1-7	BRITE RTN	Analog Ground. Use for BRITE signal return ONLY.
CN1-8	V_{SYNC}	Vertical Synchronization Input. 2.5 to $5.0V$ Logic Level. ($20Hz < f_{SYNC} < 200Hz$)
CN2 for LXMG1612-05-01 and -02 (JST SM02(8.0)B-BHS-1-TB (LF)(SN) Yeon Ho 20015WR-05A00 or SM02B-BHSS-1-TB (LF)(SN) Yeon Ho 35001WR-02A00)		
CN2-1	V_{HI}	High voltage connection to high side of lamp. Connect to lamp terminal with shortest lead length. DO NOT connect to Ground.
CN2-2	V_{LO}	Connection to low side of lamp. Connect to lamp terminal with longer lead length. DO NOT connect to Ground
CN2 for LXMG1612-05-03 (Honda QZ-19-A3MYL#02)		
CN2-3	V_{HI}	High voltage connection to high side of lamp. Connect to lamp terminal with shortest lead length. DO NOT connect to Ground.
CN2-1	V_{LO}	Connection to low side of lamp. Connect to lamp terminal with longer lead length. DO NOT connect to Ground

PHYSICAL DIMENSIONS


RECOMMENDED OPERATING CONDITIONS (R.C.)

This module has been designed to operate over a wide range of input and output conditions. However, best efficiency and performance will be obtained if the module is operated under the condition listed in the 'R.C.' column. Min. and Max. columns indicate values beyond which the inverter, although operational, will not function optimally.

Parameter	Symbol	Recommended Operating Conditions			Units
		Min	R.C.	Max	
Input Supply Voltage Range (Fully Regulated Lamp Current)	V_{IN1}	4.5	5	5.5	V
Input Supply Voltage Range (Functional)		4.35	5	5.65	
Output Power	P_O		3.5	4.0	W
Brightness Control Input Voltage Range	V_{BRT_ADJ}	0.0	2.5	V_{IN}	V
Lamp Operating Voltage	V_{LAMP}	450	535	620	V_{RMS}
Lamp Current (Full Brightness)	I_{OLAMP}		5.8		mA_{RMS}
Operating Ambient Temperature Range	T_A	0		70	$^{\circ}C$

ELECTRICAL CHARACTERISTICS

Unless otherwise specified, the following specifications apply over the recommended operating condition and ambient temperature of 25°C except where otherwise noted.

Parameter	Symbol	Test Conditions	LXMG1612-05-xx			Units
			Min	Typ	Max	
OUTPUT PIN CHARACTERISTICS						
Full Bright Lamp Current	$I_{L(MAX)}$	$V_{BRT_ADJ}=2.5V_{DC}$, $SLEEP=HIGH$, Burst Duty=100%, $V_{IN1}=5V_{DC}$	5.2	5.8	6.4	mA_{RMS}
Min. Average Lamp Current (Note 2)	$I_{L(MIN)}$	$V_{BRT_ADJ}=0V_{DC}$, $SLEEP=HIGH$, Burst Duty=2.0%, $V_{IN1}=5V_{DC}$		0.12		mA_{RMS}
Lamp Start Voltage	V_{LS}	0°C < T_A < 70°C, $V_{IN1} > 5.0V_{DC}$	1500	1650	1800	V_{RMS}
Operating Frequency	f_O	$V_{BRT_ADJ}=2.5V_{DC}$, $SLEEP=HIGH$, $V_{IN1}=5.0V$	63	68	73	kHz
BRITE INPUT						
Input Current	I_{BRT}	$V_{BRT_ADJ}=0V_{DC}$	-685	-728	-775	μA_{DC}
		$V_{BRT_ADJ}=2.5V_{DC}$	-260	-282	-305	μA_{DC}
Input Voltage for Max. Lamp Current	V_{BRT_ADJ}	$I_{O(LAMP)}=100\%$ Duty Cycle	2.30	2.35	2.40	V_{DC}
Input Voltage for Min. Lamp Current	V_{BRT_ADJ}	$I_{O(LAMP)}=$ Minimum Duty Cycle	0.0			V_{DC}
SLEEP INPUT						
RUN Mode	$V_{SLEEP(HI)}$	$V_{IN1}=4.5V$	1.9	2.1	V_{IN1}	V_{DC}
SLEEP Mode	$V_{SLEEP(LO)}$	$V_{IN1}=5.5V$	-5.0	1.9	2.0	V_{DC}
Input Current	I_{SLEEP}	$SLEEP=5.0V$	390	410	435	μA_{DC}
		$SLEEP=0V$	0.0	0.0	0.0	μA_{DC}
VSynch CHARACTERISTICS						
Logic High Level	$V_{SYNCH(HI)}$	$V_{IN1}=4.5V$	1.50	2.5	5.0	V_{DC}
	$V_{SYNCH(LO)}$	$V_{IN1}=5.5V$	-3.0	0.0	1.2	V_{DC}
Input Impedance	Z_{IN}		25	27	29	$K\Omega$
Input Frequency	f_{SYNCH}		20		200	Hz
POWER CHARACTERISTICS						
Sleep Current	$I_{IN(MIN)}$	$V_{IN1}=5V_{DC}$, $SLEEP=0.0V$	0.0	0.5	10	μA_{DC}

Note 2: Minimum lamp current required to maintain even light output may vary with display panel.

Average RMS current = (Burst Duty Cycle) x (Burst amplitude of 5.8mARMS)

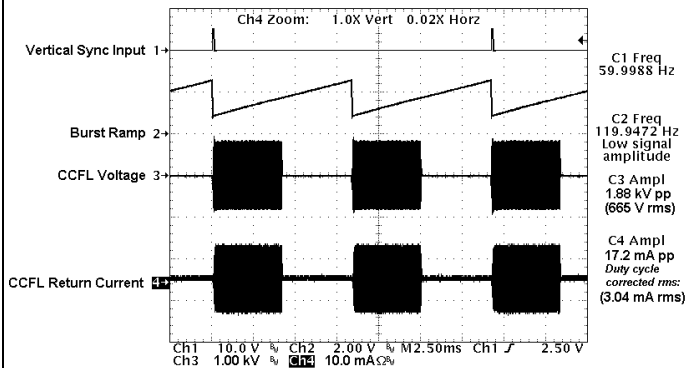
HOW RANGEMAX WORKS
LAMP VOLTAGE & LAMP CURRENT – Burst Mode Operation


Figure 1 – 50% Burst Duty Cycle

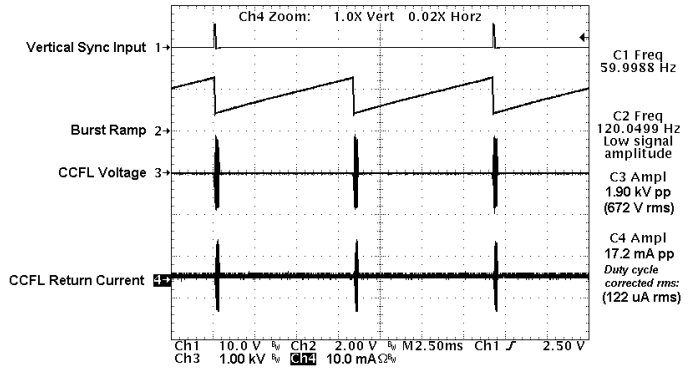


Figure 2 – 2% Burst Duty Cycle

Rather than using the traditional dimming technique of varying lamp current magnitude to adjust light output, RangeMAX inverters use a fixed lamp current value with a duty cycle control method.

The lamp current burst width can be modulated from 100% (continuous lamp current) down to a 2% duty cycle, allowing the lamp to be dimmed to less than 1% of its full brightness.

As can be seen in Trace 4 of Figure 3 at right, careful design consideration was given to controlling lamp start voltage to softly start current flow. This eliminates current overshoot that can result in premature cathode wear and reduce lamp life.

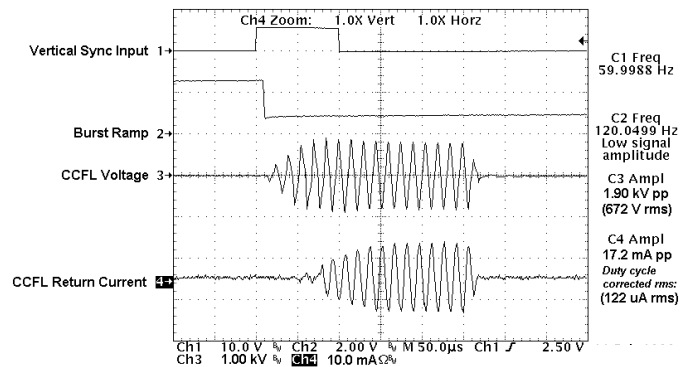


Figure 3 – 2% Burst Duty Cycle (Expanded Time Base)

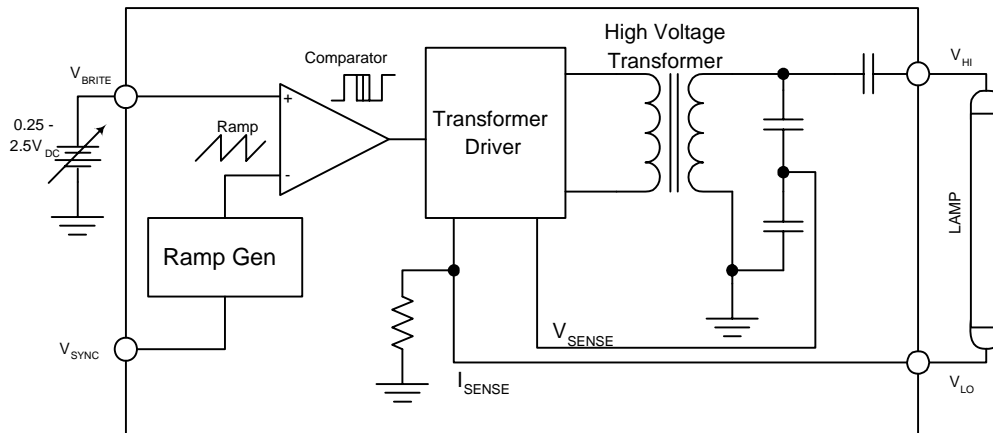
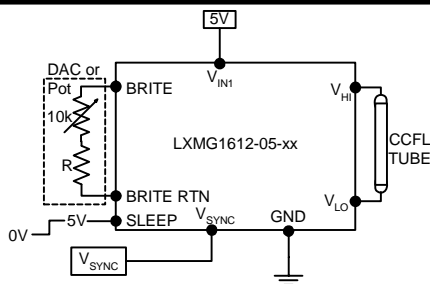
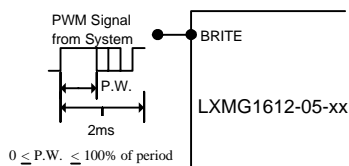


Figure 4 – RangeMAX Block Diagram

HOW RANGEMAX WORKS (CONTINUED)
Highlights

- Integrated brightness control circuit includes a DC voltage to pulse width converter that minimizes system design work and system noise susceptibility. This provides a familiar and convenient interface while reducing the potential for externally induced noise, which can cause lamp flicker.
- RangeMAX inverter modules are designed to operate with the burst frequency synchronized to the video frame rate. This provides operation with no visible display disturbances caused by beat frequencies between the lamps and video frame rates. In this synchronous mode, the inverter burst rate operates at twice the video refresh rate, well beyond standard 50/60Hz video refresh rates where the eye can perceive pulsing light.
- In applications with no access to a vertical sync., an onboard oscillator operates the inverter burst rate at about 250Hz. In this non-synchronous mode, minor display disturbances can be found under certain video conditions. This performance may be acceptable for many applications, but synchronization must be used when no disturbance can be tolerated.
- A single input will accommodate negative and positive vertical sync pulses at any pulse width.
- Separate feedback loops for lamp current and open circuit voltage regulation insure reliable strike under all operating conditions, automatic over-voltage prevention with broken or failed lamps, and accurate lamp current regulation.

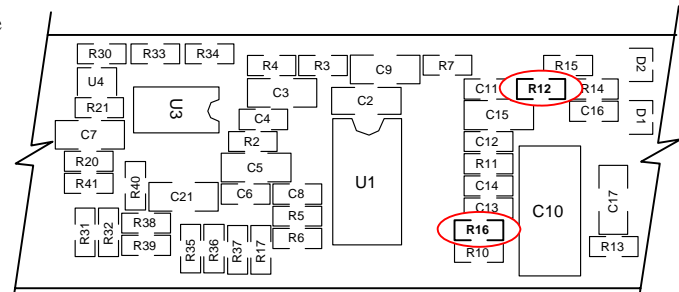
TYPICAL APPLICATION

Figure 5 - Potentiometer Brightness Control

Figure 5A - PWM Brightness Control

- The brightness control may be a voltage output DAC, digital resistor or a simple 10k potentiometer. If desired, an additional series resistor with the 10k potentiometer can be used to set a higher minimum brightness setting as shown in Figure 5. A 2.5V to 5V Logic Level PWM signal from a micro-controller may also be used as shown in Figure 5A.
- If synchronization to the video frame rate is desired, connect the vertical sync pulse from the system video controller to the V_SYNC input. If no video synchronization is desired, connect V_SYNC to ground.
- If you need to turn the inverter ON/OFF remotely, connect to 2.5V to 5V logic signal to the SLEEP input.
- Connect V_HI to high voltage wire from the lamp. Connect V_LO to the low voltage wire (wire with thinner insulation). Never connect V_LO to circuit ground as this will defeat lamp current regulation. If both lamp wires have heavy high voltage insulation, connect the longest wire to V_LO. This wire is typically white.

LXMG1612-05-XX OUTPUT CURRENT ADJUST

The LXMG1612-05 output current can be adjusted by changing the value of two resistors on the PCB. The following table shows the approximate new output current values:

Output Current	R12	R16
7.0mA	2.00K 1%	Not Used
6.0mA	2.61K 1%	Not Used
5.8mA	2.74K 1%	Not Used
5.0mA	2.74K 1%	499K 1%
4.0mA	2.74K 1%	178K 1%
3.0mA	2.74K 1%	78.7K 1%


Figure 6- Component Replacement Locations



LXMG1612-05-xx

5V Highly-Integrated, Digital Dimming CCFL Inverter Module

PRODUCTION DATASHEET

NOTES

PRODUCTION DATA – Information contained in this document is proprietary to Microsemi and is current as of publication date. This document may not be modified in any way without the express written consent of Microsemi. Product processing does not necessarily include testing of all parameters. Microsemi reserves the right to change the configuration and performance of the product and to discontinue product at any time.