

STANDARD

Resistive Touch Panel Specification

FID-550 7-Wire Series

RoHS compliant

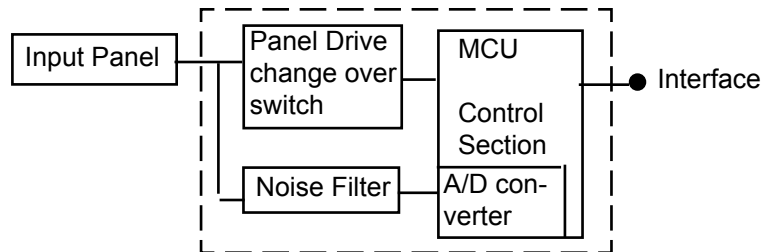

■ FEATURES

- Superior long life, using a unique construction method offering improved life over typical technologies; by sensing data input only on the glass layer, typically a 10x improvement in product life is achieved.
- Excellent specification and high quality
 - Anti-Newton ring technology
 - High reliability materials
- Pen/Finger, Pen Only, Finger Only, Light Touch types available
- Transparency 80% - typical
- RoHS Compliant

■ PART NUMBERS

Touch Panels:

Part Number	Size	Type
N010-0510-T303	17.0"	Pen/Finger
N010-0510-T304	17.0"	Pen/Finger
N010-0510-T236	15.0"	Pen/Finger
N010-0510-T219	15.0"	Pen/Finger
N010-0550-T717	12.1"	Pen/Finger
N010-0551-T742	12.1"	Pen/Finger

Part Number	Size	Type
N010-0551-T744	12.1"	Pen/Finger
N010-0550-T603	10.4"	Pen only
N010-0550-T613	10.4"	Pen/Finger
N010-0550-T625	10.4"	Pen/Finger (light touch type)
N010-0550-T627	10.4"	Pen/Finger (light touch type) 100mm tail
N010-0550-T345	8.4"	Pen/Finger

■ PART NUMBERS

Controller Boards:

Part Number	Type
N16B-0558-B280	7-Wire, RS232
N16B-0558-B740	7-Wire, USB

■ PART NUMBERS

Interface Controller Chips:

Part Number	Type
N010-0559-V026	7-Wire, RS232
NC41120-0017	7-Wire, USB

■ DIMENSION EXAMPLE (10.4" SHOWN)

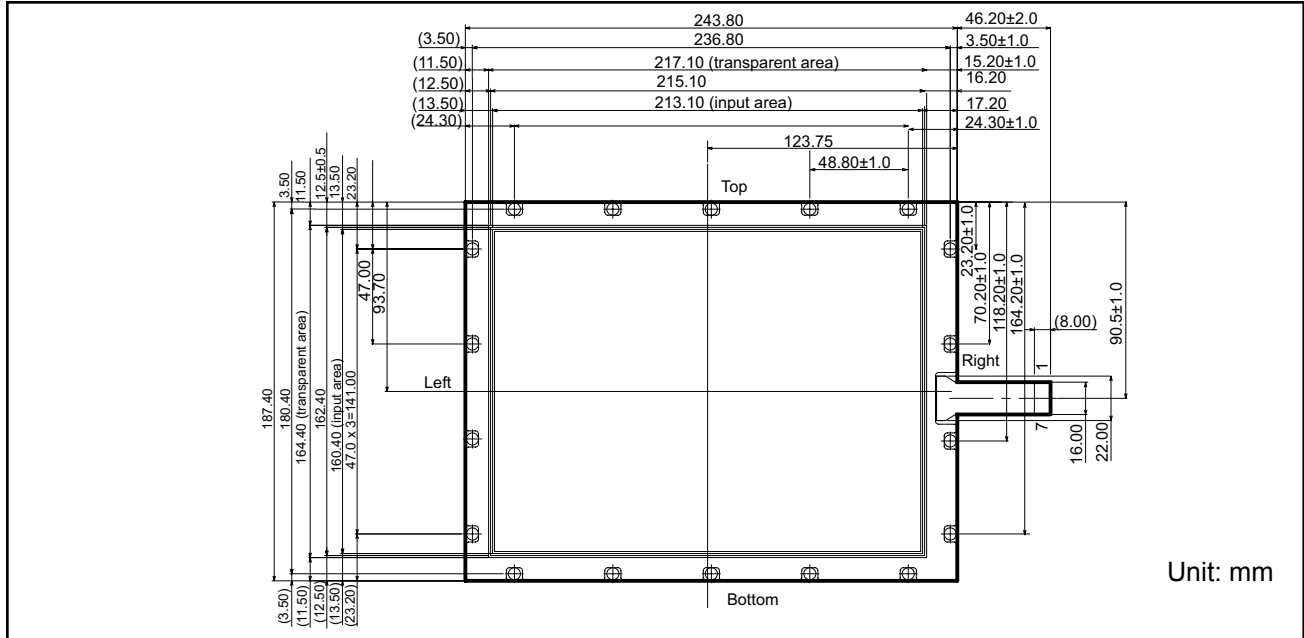

■ DETAILED SPECIFICATION

■ 1.0 APPLICATION

This specification applies to the standard FID-550 series Touch Panel (Pen/Finger type).

■ 2.0 ADDITIONAL APPLICATIONS

Complete specification document is available upon request for customers with whom we have an approved NDA in place.

■ 3.0 DISCRIPTION AND BLOCK DIAGRAM

This panel in combination with a control IC chip is used to transfer the co-ordinates of the touched position to the host system (see block diagram above).

■ 4.0 DRAWING (Please see the diagram above.)

Definitions of the major dimensions indicated on this diagram:

Effective Input Area (A) Area guaranteed to meet all the characteristics detailed in this specification

View / Transparent Area (B) The area inside the adhesive zone or electrode pattern.

Anti-input Area (C) An insulating area allowed to protect the touch panel from giving false readings when an enclosure touches the panel.

■ 5.0 CHARACTERISTICS

■ 5.1 MECHANICAL

Operating Force 0.05~0.49 N (5 ~ 50gF) Measured with a Silicon Measurement Rod R 8 (Round type 8mm) Silicon Rubber Hardness 60°C

Hardness of Surface Pencil hardness 3H minimum against specification JIS K-5400

■ 5.2 OPTICAL

Transparency 78% min measured in the effective input area to JIS K 7105 using a MURAKAMI SHIKISAI KENKYUSHO type IIR 100 meter. Typically 80%.

Haze 5% measured in the effective input area using a MURAKAMI SHIKISAI KENKYUSHO type IIR 100 meter with an Anti Glare treated surface.

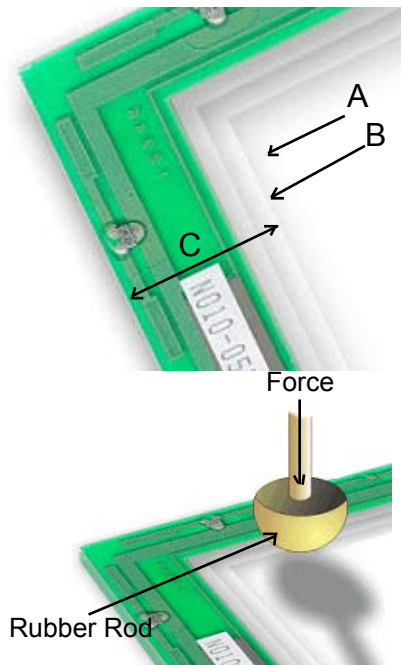

■ 5.6 FINGER LIFE



A finger is simulated by a silicon rubber plunger R8 (Round type 8mm size) hardness 60°C at 200g at frequency 5Hz.

A failure is judged to happen when the current consumption or insulation resistance or dielectric strength are not met as shown in 5.3. The location accuracy with 9 point calibration must be ± 4.4 mm max. Typical operating force is 150g max.

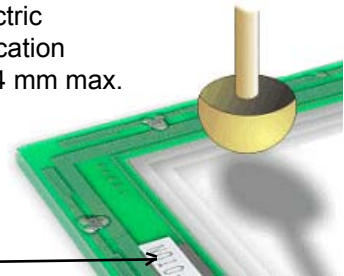

■ 5.7 INFORMATION ON THE PANEL

The panel part number is visible from the film side
The production information is visible from the glass side.
Production year 99 00 etc.

1 2 3 4 5 6 7 8 9 X Y Z or 1 2 3 4 5 6 7 8 9 X Y Z	January Production
□ 2 3 4 5 6 7 8 9 X Y Z or ○ 2 3 4 5 6 7 8 9 X Y Z	February Production
□ □ □ □ □ □ □ □ □ □ Z or 1 2 3 4 5 6 7 8 9 ○ Y Z	December Production

■ 6 PACKAGING

■ 6.1 PACKING SPECIFICATION

Vibration: 10~55 Hz at 1 Octave per minute 10G 20 cycles with one side 0.75mm
Drop test: 60cm Drop 1 corner, 3 crease lines and 6 faces. 1 each 1 time
After the test no glass: flaw or crack is seen, and no dent or scratch on the film.
Also glass and film must not separate.

■ 6.1 PACKING DETAILS

Each touch panel is placed into a plastic bag and is held in place by a slit cut into the side of the cardboard. A second insertion piece is placed into the carton to again add stability. The qty is written on the side of the box. For example the T611 has 26 pieces per box.

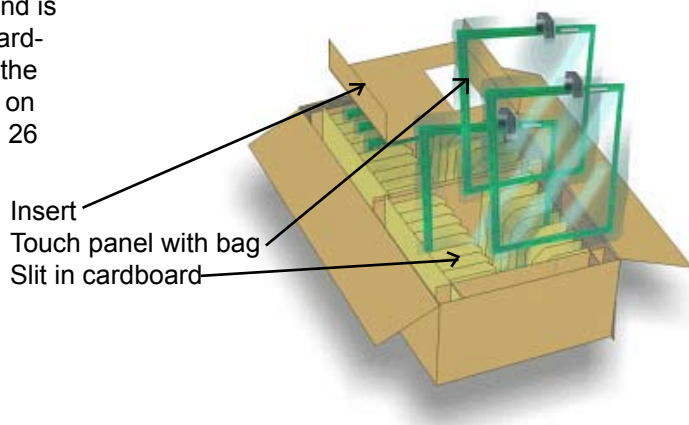

■ 7.0 REJECT CRITERIA

Description		Reject Criteria	
Film Dent		Area $\geq 0.1\text{mm}^2$ Area $\geq 0.05\text{mm}^2$ & area $< 0.1\text{mm}^2$ Area $< 0.05\text{mm}^2$: to be zero : to be max. 5 points : none specified
Foreign material between glass and film	Dot type	Area $> 0.1\text{mm}^2$ Area $\geq 0.05\text{mm}^2$ & area $< 0.1\text{mm}^2$ Area $< 0.05\text{mm}^2$: to be zero : to be max. 5 points : none specified
	Line type	Area $> 0.1\text{mm}$ Area $\geq 0.03\text{mm}$ & width $< 0.1\text{mm}$ and length $< 10\text{mm}$ Area $< 0.05\text{mm}$: to be zero : to be max. 1 point : none specified
Scratch		Area $\geq 0.1\text{mm}$ Area $\geq 0.03\text{mm}$ & width $< 0.1\text{mm}$ with length $< 80\text{mm}$ Area $< 0.03\text{mm}$ & width $< 0.1\text{mm}$ with length $< 30\text{mm}$: to be zero : to be max. 1 point : none specified
Dot blur or hard coat missing		Area $\geq 0.5\text{mm}^2$ Area $\geq 0.03\text{mm}^2$ & area $< 0.5\text{mm}^2$ Area $< 0.05\text{mm}^2$: to be zero : to be max. 5 points : none specified
Newton Ring		These must not be seen from Panel film side under a fluorescent lamp (3 wavelength type lamp). Not to be verified from glass side.	
Glass flaw		To be no flaw which is bigger than that shown in the following diagram. The number of flaws is not specified.	

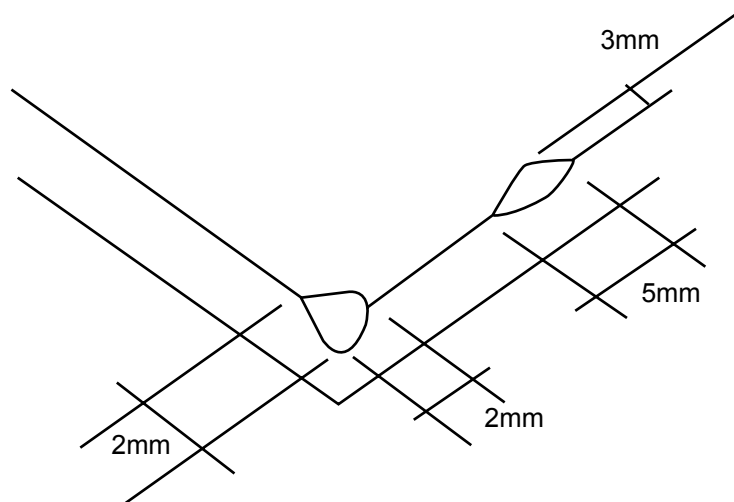

■ 8.0 GENERAL POINTS OF CAUTION

Touch panels are made of glass, so care must be taken in handling them. Do not stress, pile, bend, lift by the cable or put any stress on the film, for example moving by film face vacuum. In order to clean wring dry a cloth which has been emersed in a natural detergent. DO NOT use any organic solvent, acid or alkali solution. Watch the edge of the panel when cleaning, again for safety reasons.

9.0 CONNECTION AND MOUNTING

The details below indicate the recommended mounting structure for panel and enclosure. The enclosure support to fix the touch panel must be over 1.0mm width and must be outside the view (Transparent area). Also ensure that the enclosure does not cause miss input by touching the view area.

The following diagram shows that the enclosure edge must be between the View area and the guaranteed active area. Ensure space is allocated for the diodes, and we recommend that the material to fix the panel and enclosure is elastic. Special design would be required to stop water ingress. The corners of the touch panel are conductive so do not touch any metal parts after mounting.

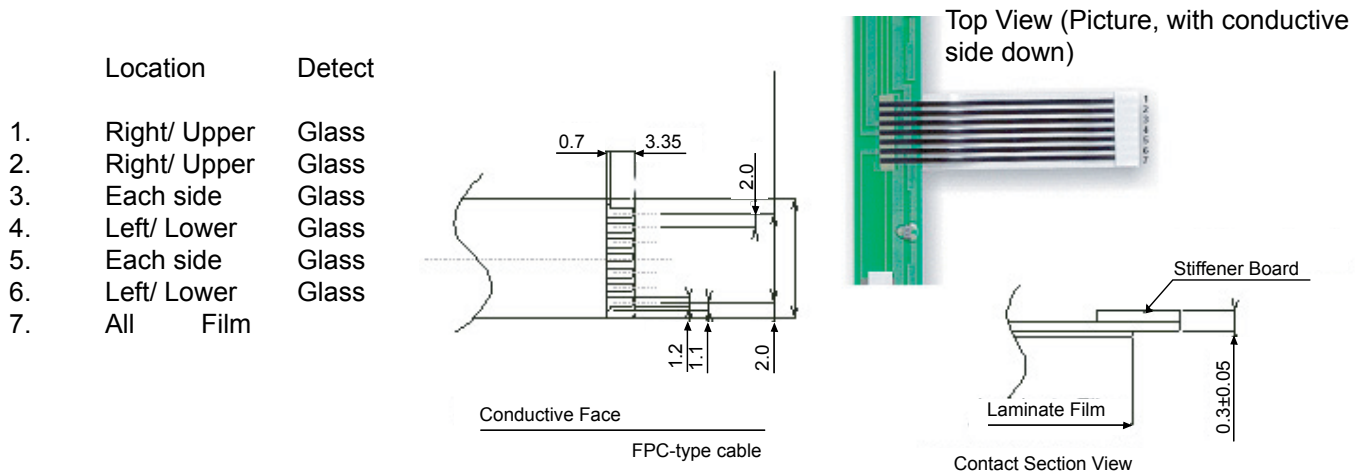

Bottom View (Drawing, with conductive side up)

(Mating connector type FCI or equivalent SFW15R-1STAE1-LF: for FPC)

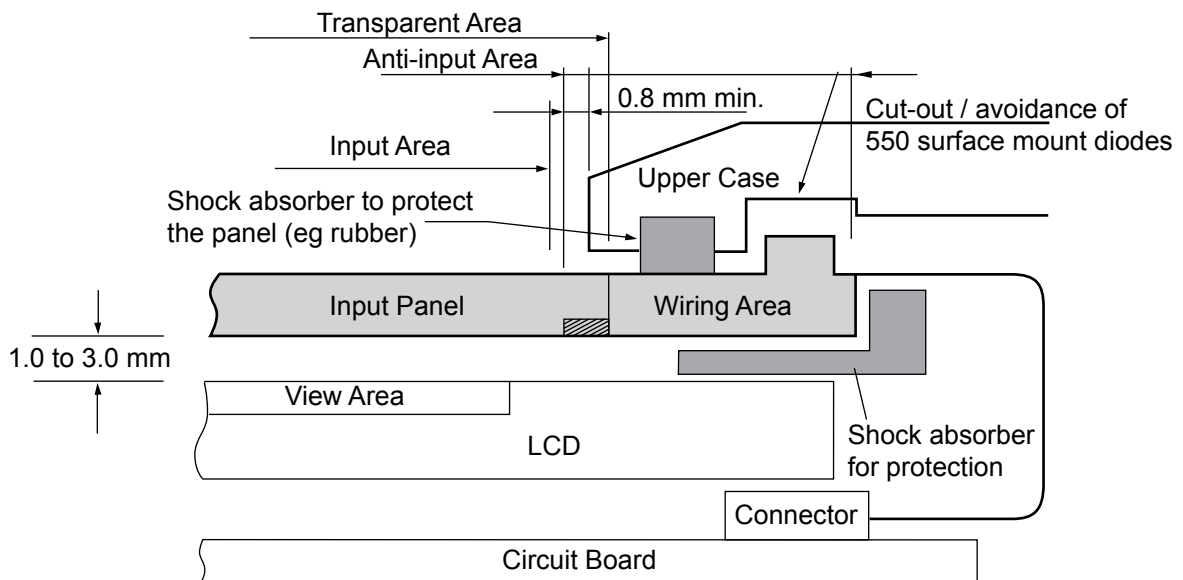

■ 10.0 PANEL THICKNESS

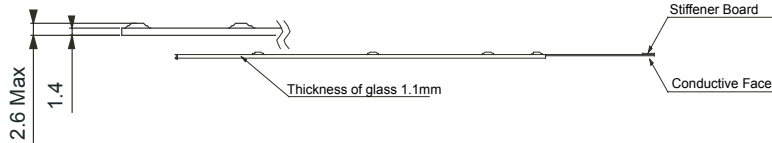

Fujitsu Components International Headquarter Offices

Japan

Fujitsu Component Limited
Gotanda-Chuo Building
3-5, Higashigotanda 2-chome, Shinagawa-ku
Tokyo 141 8630, Japan
Tel: (81-3) 5449-7010
Fax: (81-3) 5449-2626
Email: promothq@fcl.fujitsu.com
Web: www.fcl.fujitsu.com

North and South America

Fujitsu Components America, Inc.
250 E. Caribbean Drive
Sunnyvale, CA 94089 U.S.A.
Tel: (1-408) 745-4900
Fax: (1-408) 745-4970
Email: components@us.fujitsu.com
Web: <http://us.fujitsu.com/components/>

Europe

Fujitsu Components Europe B.V.
Diamantlaan 25
2132 WV Hoofddorp
Netherlands
Tel: (31-23) 5560910
Fax: (31-23) 5560950
Email: info@fceu.fujitsu.com
Web: emea.fujitsu.com/components/

Asia Pacific

Fujitsu Components Asia Ltd.
102E Pasir Panjang Road
#01-01 Citilink Warehouse Complex
Singapore 118529
Tel: (65) 6375-8560
Fax: (65) 6273-3021
Email: fcsl@fcal.fujitsu.com
Web: <http://www.fujitsu.com/sg/services/micro/components/>

©2007 Fujitsu Components America, Inc. All rights reserved. All trademarks or registered trademarks are the property of their respective owners.

Fujitsu Components America or its affiliates do not warrant that the content of datasheet is error free. In a continuing effort to improve our products Fujitsu Components America, Inc. or its affiliates reserve the right to change specifications/datasheets without prior notice.
Rev. May 30, 2007.