



T-73-13-03

## LM131A/LM131, LM231A/LM231, LM331A/LM331 Precision Voltage-to-Frequency Converters

### General Description

The LM131/LM231/LM331 family of voltage-to-frequency converters are ideally suited for use in simple low-cost circuits for analog-to-digital conversion, precision frequency-to-voltage conversion, long-term integration, linear frequency modulation or demodulation, and many other functions. The output when used as a voltage-to-frequency converter is a pulse train at a frequency precisely proportional to the applied input voltage. Thus, it provides all the inherent advantages of the voltage-to-frequency conversion techniques, and is easy to apply in all standard voltage-to-frequency converter applications. Further, the LM131A/LM231A/LM331A attains a new high level of accuracy versus temperature which could only be attained with expensive voltage-to-frequency modules. Additionally the LM131 is ideally suited for use in digital systems at low power supply voltages and can provide low-cost analog-to-digital conversion in microprocessor-controlled systems. And, the frequency from a battery powered voltage-to-frequency converter can be easily channeled through a simple photoisolator to provide isolation against high common mode levels.

The LM131/LM231/LM331 utilizes a new temperature-compensated band-gap reference circuit, to provide excellent accuracy over the full operating temperature range, at power supplies as low as 4.0V. The precision timer circuit

has low bias currents without degrading the quick response necessary for 100 kHz voltage-to-frequency conversion. And the output is capable of driving 3 TTL loads, or a high voltage output up to 40V, yet is short-circuit-proof against  $V_{CC}$ .

### Features

- Guaranteed linearity 0.01% max
- Improved performance in existing voltage-to-frequency conversion applications
- Split or single supply operation
- Operates on single 5V supply
- Pulse output compatible with all logic forms
- Excellent temperature stability,  $\pm 50$  ppm/ $^{\circ}\text{C}$  max
- Low power dissipation, 15 mW typical at 5V
- Wide dynamic range, 100 dB min at 10 kHz full scale frequency
- Wide range of full scale frequency, 1 Hz to 100 kHz
- Low cost

### Typical Applications

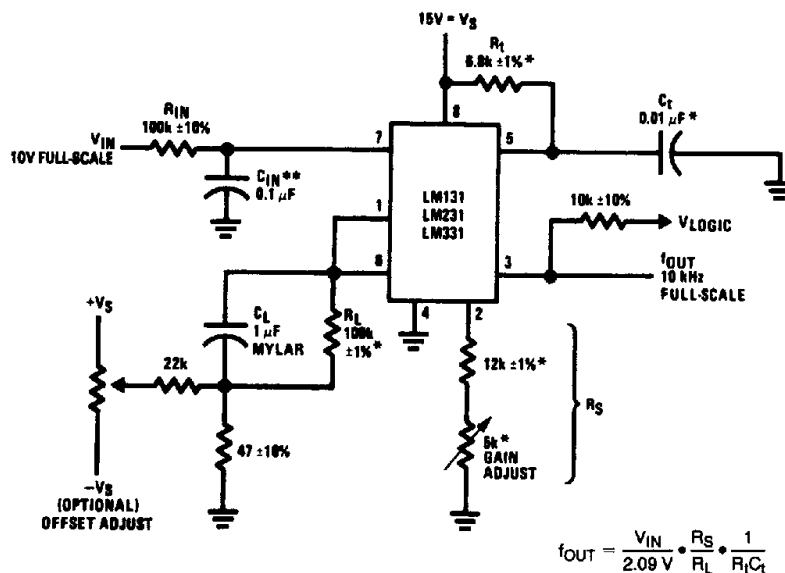

TL/H/5680-1

\*Use stable components with low temperature coefficients. See Typical Applications section.

\*\*0.1  $\mu\text{F}$  or 1  $\mu\text{F}$ , See "Principles of Operation."

**FIGURE 1. Simple Stand-Alone Voltage-to-Frequency Converter  
with  $\pm 0.03\%$  Typical Linearity ( $f = 10$  Hz to 11 kHz)**

## NATL SEMICON (LINEAR)

**Absolute Maximum Ratings** (Note 1)

If Military/Aerospace specified devices are required, please contact the National Semiconductor Sales Office/Distributors for availability and specifications.

	LM131A/LM131	LM231A/LM231	LM331A/LM331
Supply Voltage	40V	40V	40V
Output Short Circuit to Ground	Continuous	Continuous	Continuous
Output Short Circuit to $V_{CC}$	Continuous	Continuous	Continuous
Input Voltage	-0.2V to $+V_S$	-0.2V to $+V_S$	-0.2V to $+V_S$
Operating Ambient Temperature Range	$T_{MIN}$ $T_{MAX}$ -55°C to +125°C	$T_{MIN}$ $T_{MAX}$ -25°C to +85°C	$T_{MIN}$ $T_{MAX}$ 0°C to +70°C
Power Dissipation ( $P_D$ at 25°C) and Thermal Resistance ( $\theta_{JA}$ )			
(H Package) $P_D$	670 mW	570 mW	570 mW
$\theta_{JA}$	150°C/W	150°C/W	150°C/W
(N Package) $P_D$		1.25W	1.25W
$\theta_{JA}$		100°C/W	100°C/W
(M Package) $P_D$		1.25W	
$\theta_{JA}$		85°C/W	
Lead Temperature (Soldering, 10 sec.)			
Dual-In-Line Package (Plastic)	260°C	260°C	260°C
Metal Can Package (TO-5)	260°C	260°C	260°C
ESD Susceptibility (Note 4)			
Metal Can Package (TO-5)	2000V	2000V	2000V
Other Packages		500V	500V

**Electrical Characteristics**  $T_A = 25^\circ\text{C}$  unless otherwise specified (Note 2)

Parameter	Conditions	Min	Typ	Max	Units
VFC Non-Linearity (Note 3)	$4.5\text{V} \leq V_S \leq 20\text{V}$		$\pm 0.003$	$\pm 0.01$	% Full-Scale
	$T_{MIN} \leq T_A \leq T_{MAX}$		$\pm 0.006$	$\pm 0.02$	% Full-Scale
VFC Non-Linearity In Circuit of Figure 1	$V_S = 15\text{V}$ , $f = 10\text{ Hz to } 11\text{ kHz}$		$\pm 0.024$	$\pm 0.14$	% Full-Scale
Conversion Accuracy Scale Factor (Gain) LM131, LM131A, LM231, LM231A LM331, LM331A	$V_{IN} = -10\text{V}$ , $R_S = 14\text{ k}\Omega$	0.95	1.00	1.05	kHz/V
		0.90	1.00	1.10	kHz/V
Temperature Stability of Gain LM131/LM231/LM331 LM131A/LM231A/LM331A	$T_{MIN} \leq T_A \leq T_{MAX}$ , $4.5\text{V} \leq V_S \leq 20\text{V}$		$\pm 30$	$\pm 150$	ppm/°C
			$\pm 20$	$\pm 50$	ppm/°C
Change of Gain with $V_S$	$4.5\text{V} \leq V_S \leq 10\text{V}$		0.01	0.1	%/V
	$10\text{V} \leq V_S \leq 40\text{V}$		0.006	0.06	%/V
Rated Full-Scale Frequency	$V_{IN} = -10\text{V}$	10.0			kHz
Gain Stability vs Time (1000 Hrs)	$T_{MIN} \leq T_A \leq T_{MAX}$		$\pm 0.02$		% Full-Scale
Overrange (Beyond Full-Scale) Frequency	$V_{IN} = -11\text{V}$	10			%
<b>INPUT COMPARATOR</b>					
Offset Voltage LM131/LM231/LM331 LM131A/LM231A/LM331A	$T_{MIN} \leq T_A \leq T_{MAX}$ $T_{MIN} \leq T_A \leq T_{MAX}$		$\pm 3$	$\pm 10$	mV
			$\pm 4$	$\pm 14$	mV
			$\pm 3$	$\pm 10$	mV
Bias Current			-80	-300	nA
Offset Current			$\pm 8$	$\pm 100$	nA
Common-Mode Range	$T_{MIN} \leq T_A \leq T_{MAX}$	-0.2		$V_{CC} - 2.0$	V

**Electrical Characteristics**  $T_A = 25^\circ\text{C}$  unless otherwise specified (Note 2) (Continued)

Parameter	Conditions	Min	Typ	Max	Units
<b>TIMER</b>					
Timer Threshold Voltage, Pin 5		0.63	0.667	0.70	$\times V_S$
Input Bias Current, Pin 5	$V_S = 15\text{V}$ $0\text{V} \leq V_{\text{PIN } 5} \leq 9.9\text{V}$		$\pm 10$	$\pm 100$	nA
All Devices	$V_{\text{PIN } 5} = 10\text{V}$		200	1000	nA
LM131/LM231/LM331	$V_{\text{PIN } 5} = 10\text{V}$		200	500	nA
$V_{\text{SAT PIN } 5}$ (Reset)	$I = 5\text{ mA}$		0.22	0.5	V
<b>CURRENT SOURCE (Pin 1)</b>					
Output Current	$R_S = 14\text{ k}\Omega$ , $V_{\text{PIN } 1} = 0$				$\mu\text{A}$
LM131, LM131A, LM231, LM231A		126	135	144	$\mu\text{A}$
LM331, LM331A		116	136	156	$\mu\text{A}$
Change with Voltage	$0\text{V} \leq V_{\text{PIN } 1} \leq 10\text{V}$		0.2	1.0	$\mu\text{A}$
Current Source OFF Leakage					nA
LM131, LM131A			0.01	1.0	nA
LM231, LM231A, LM331, LM331A			0.02	10.0	nA
All Devices	$T_A = T_{\text{MAX}}$		2.0	50.0	nA
Operating Range of Current (Typical)			(10 to 500)		$\mu\text{A}$
<b>REFERENCE VOLTAGE (Pin 2)</b>					
LM131, LM131A, LM231, LM231A		1.76	1.89	2.02	$V_{\text{DC}}$
LM331, LM331A		1.70	1.89	2.08	$V_{\text{DC}}$
Stability vs Temperature			$\pm 60$		ppm/ $^\circ\text{C}$
Stability vs Time, 1000 Hours			$\pm 0.1$		%
<b>LOGIC OUTPUT (Pin 3)</b>					
$V_{\text{SAT}}$	$I = 5\text{ mA}$		0.15	0.50	V
OFF Leakage	$I = 3.2\text{ mA}$ (2 TTL Loads), $T_{\text{MIN}} \leq T_A \leq T_{\text{MAX}}$		0.10	0.40	V
			$\pm 0.05$	1.0	$\mu\text{A}$
<b>SUPPLY CURRENT</b>					
LM131, LM131A, LM231, LM231A	$V_S = 5\text{V}$	2.0	3.0	4.0	mA
	$V_S = 40\text{V}$	2.5	4.0	6.0	mA
LM331, LM331A	$V_S = 5\text{V}$	1.5	3.0	6.0	mA
	$V_S = 40\text{V}$	2.0	4.0	8.0	mA

**Note 1:** Absolute Maximum Ratings indicate limits beyond which damage to the device may occur. DC and AC electrical specifications do not apply when operating the device beyond its specified operating conditions.

**Note 2:** All specifications apply in the circuit of Figure 3, with  $4.0\text{V} \leq V_S \leq 40\text{V}$ , unless otherwise noted.

**Note 3:** Nonlinearity is defined as the deviation of  $I_{\text{OUT}}$  from  $V_{\text{IN}} \times (10\text{ kHz} / -10\text{ V}_{\text{DC}})$  when the circuit has been trimmed for zero error at 10 Hz and at 10 kHz, over the frequency range 1 Hz to 11 kHz. For the timing capacitor,  $C_T$ , use NPO ceramic, Teflon®, or polystyrene.

**Note 4:** Human body model, 100 pF discharged through a 1.5 k $\Omega$  resistor.

NATL SEMICON (LINEAR)

LM131A/LM131/LM231A/LM231/LM331A/LM331

NATL SEMICOND (LINEAR)

Functional Block Diagram

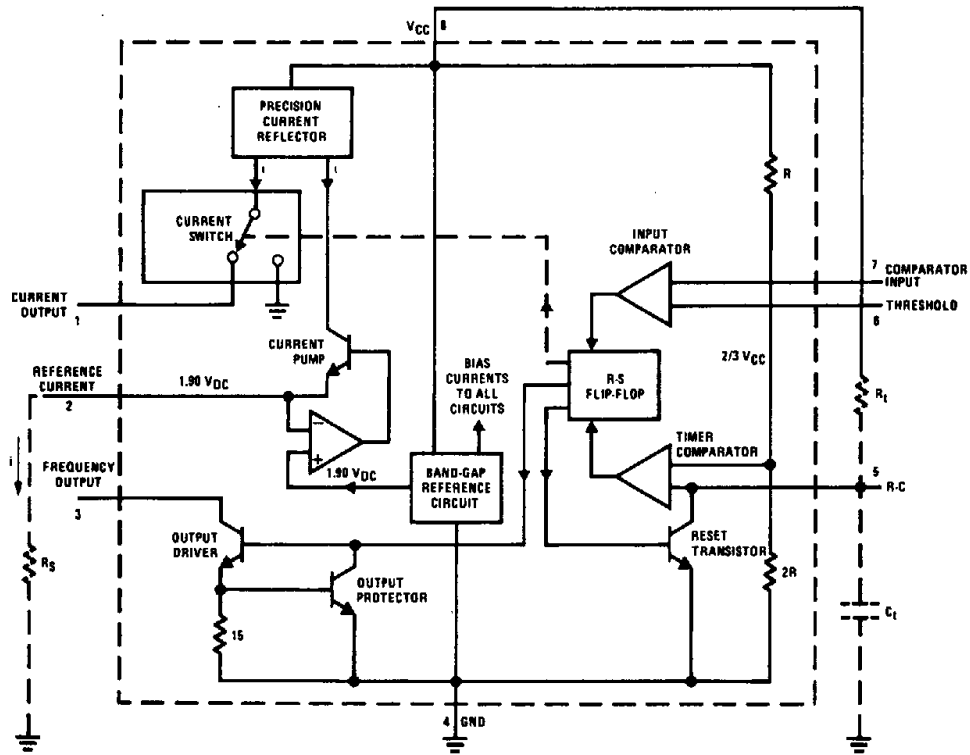

Pin numbers apply to 8-pin packages only. See connection diagram for LM231WM pin numbers.

FIGURE 1a

TL/H/5680-2

# Typical Performance Characteristics

(All electrical characteristics apply for the circuit of *Figure 3*, unless otherwise noted.)

**Nonlinearity Error, LM131 Family, as Precision V-to-F Converter (*Figure 3*)**

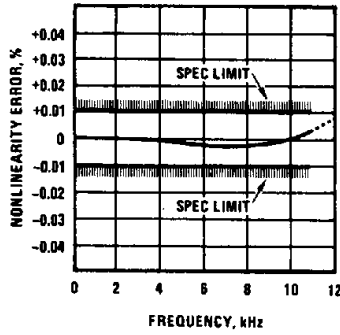

**Nonlinearity Error, LM131 Family**

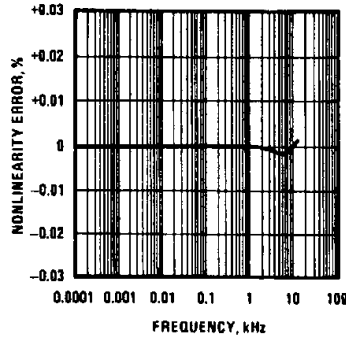

**Nonlinearity vs Power Supply Voltage**

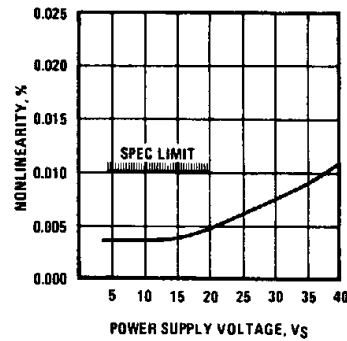

**Frequency vs Temperature, LM131A**

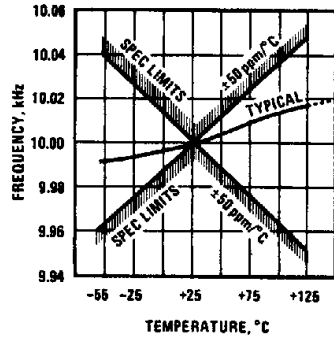

**VREF vs Temperature, LM131A**

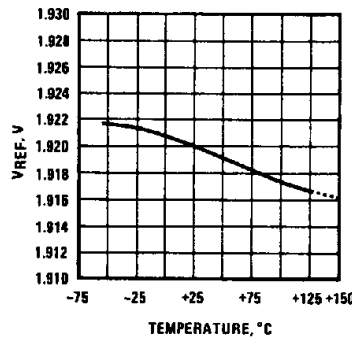

**Output Frequency vs VSUPPLY**

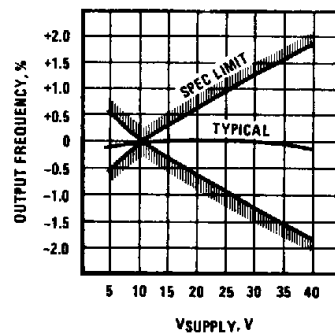

**100 kHz Nonlinearity Error, LM131 Family (*Figure 4*)**

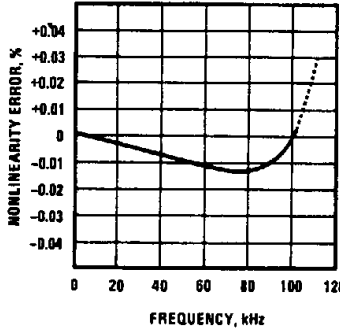

**Nonlinearity Error, LM131 (*Figure 1*)**

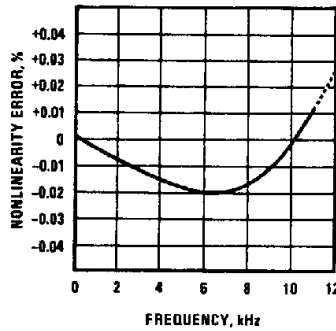

**Input Current (Pins 6, 7) vs Temperature**

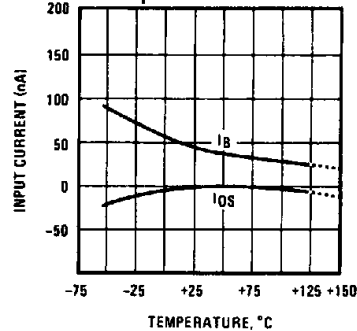

**Power Drain vs VSUPPLY**

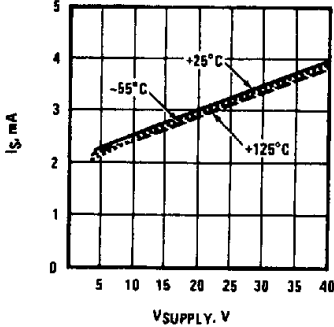

**Output Saturation Voltage vs IOUT (Pin 3)**

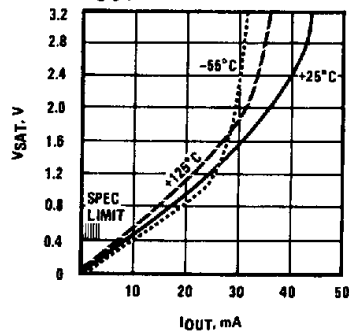

**Nonlinearity Error, Precision F-to-V Converter (*Figure 6*)**

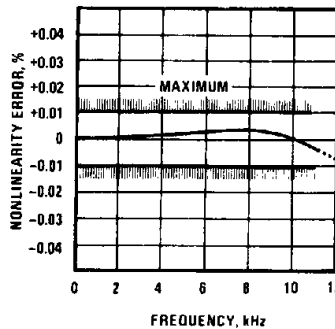

TL/H/5680-3

## Typical Applications (Continued)

### PRINCIPLES OF OPERATION OF A SIMPLIFIED VOLTAGE-TO-FREQUENCY CONVERTER

The LM131 is a monolithic circuit designed for accuracy and versatile operation when applied as a voltage-to-frequency (V-to-F) converter or as a frequency-to-voltage (F-to-V) converter. A simplified block diagram of the LM131 is shown in *Figure 2* and consists of a switched current source, input comparator, and 1-shot timer.

The operation of these blocks is best understood by going through the operating cycle of the basic V-to-F converter, *Figure 2*, which consists of the simplified block diagram of the LM131 and the various resistors and capacitors connected to it.

The voltage comparator compares a positive input voltage,  $V_1$ , at pin 7 to the voltage,  $V_x$ , at pin 6. If  $V_1$  is greater, the comparator will trigger the 1-shot timer. The output of the timer will turn ON both the frequency output transistor and the switched current source for a period  $t = 1.1 R_1 C_1$ . During this period, the current  $i$  will flow out of the switched current source and provide a fixed amount of charge,  $Q = i \times t$ , into the capacitor,  $C_L$ . This will normally charge  $V_x$  up to a higher level than  $V_1$ . At the end of the timing period, the current  $i$  will turn OFF, and the timer will reset itself.

Now there is no current flowing from pin 1, and the capacitor  $C_L$  will be gradually discharged by  $R_L$  until  $V_x$  falls to the level of  $V_1$ . Then the comparator will trigger the timer and start another cycle.

The current flowing into  $C_L$  is exactly  $I_{AVE} = i \times (1.1 \times R_1 C_1) \times f$ , and the current flowing out of  $C_L$  is exactly  $V_x / R_L \cong V_{IN} / R_L$ . If  $V_{IN}$  is doubled, the frequency will double to maintain this balance. Even a simple V-to-F converter can provide a frequency precisely proportional to its input voltage over a wide range of frequencies.

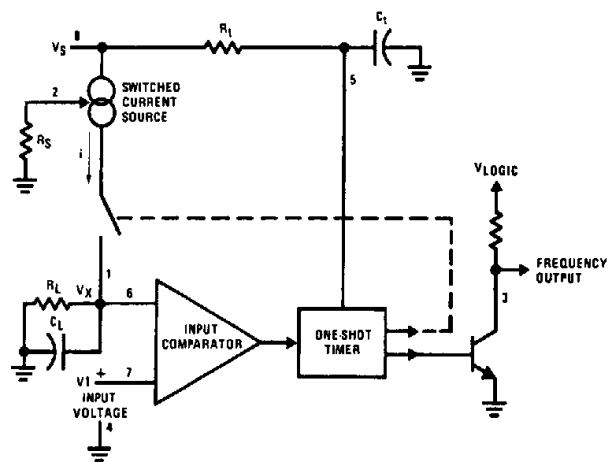

TL/H/5680-4

**FIGURE 2. Simplified Block Diagram of Stand-Alone Voltage-to-Frequency Converter Showing LM131 and External Components**

### DETAIL OF OPERATION, FUNCTIONAL BLOCK DIAGRAM (FIGURE 1a)

The block diagram shows a band gap reference which provides a stable  $1.9 V_{DC}$  output. This  $1.9 V_{DC}$  is well regulated over a  $V_S$  range of 3.9V to 40V. It also has a flat, low temperature coefficient, and typically changes less than  $\frac{1}{2}\%$  over a  $100^\circ\text{C}$  temperature change.

The current pump circuit forces the voltage at pin 2 to be at 1.9V, and causes a current  $i = 1.90V/R_S$  to flow. For  $R_S = 14k$ ,  $i = 135 \mu\text{A}$ . The precision current reflector provides a current equal to  $i$  to the current switch. The current switch switches the current to pin 1 or to ground depending on the state of the  $R_S$  flip-flop.

The timing function consists of an  $R_S$  flip-flop, and a timer comparator connected to the external  $R_1 C_1$  network. When the input comparator detects a voltage at pin 7 higher than pin 6, it sets the  $R_S$  flip-flop which turns ON the current switch and the output driver transistor. When the voltage at pin 5 rises to  $\frac{2}{3} V_{CC}$ , the timer comparator causes the  $R_S$  flip-flop to reset. The reset transistor is then turned ON and the current switch is turned OFF.

However, if the input comparator still detects pin 7 higher than pin 6 when pin 5 crosses  $\frac{2}{3} V_{CC}$ , the flip-flop will not be reset, and the current at pin 1 will continue to flow, in its attempt to make the voltage at pin 6 higher than pin 7. This condition will usually apply under start-up conditions or in the case of an overload voltage at signal input. It should be noted that during this sort of overload, the output frequency will be 0; as soon as the signal is restored to the working range, the output frequency will be resumed.

The output driver transistor acts to saturate pin 3 with an ON resistance of about  $50\Omega$ . In case of overvoltage, the output current is actively limited to less than 50 mA.

The voltage at pin 2 is regulated at  $1.90 V_{DC}$  for all values of  $i$  between  $10 \mu\text{A}$  to  $500 \mu\text{A}$ . It can be used as a voltage reference for other components, but care must be taken to ensure that current is not taken from it which could reduce the accuracy of the converter.

### PRINCIPLES OF OPERATION OF BASIC VOLTAGE-TO-FREQUENCY CONVERTER (FIGURE 1)

The simple stand-alone V-to-F converter shown in *Figure 1* includes all the basic circuitry of *Figure 2* plus a few components for improved performance.

A resistor,  $R_{IN} = 100 k\Omega \pm 10\%$ , has been added in the path to pin 7, so that the bias current at pin 7 ( $-80 \text{ nA}$  typical) will cancel the effect of the bias current at pin 6 and help provide minimum frequency offset.

The resistance  $R_S$  at pin 2 is made up of a  $12 k\Omega$  fixed resistor plus a  $5 k\Omega$  (cermet, preferably) gain adjust rheostat. The function of this adjustment is to trim out the gain tolerance of the LM131, and the tolerance of  $R_1$ ,  $R_L$  and  $C_1$ .

## Typical Applications (Continued)

For best results, all the components should be stable low-temperature-coefficient components, such as metal-film resistors. The capacitor should have low dielectric absorption; depending on the temperature characteristics desired, NPO ceramic, polystyrene, Teflon or polypropylene are best suited.

A capacitor  $C_{IN}$  is added from pin 7 to ground to act as a filter for  $V_{IN}$ . A value of  $0.01 \mu\text{F}$  to  $0.1 \mu\text{F}$  will be adequate in most cases; however, in cases where better filtering is required, a  $1 \mu\text{F}$  capacitor can be used. When the RC time constants are matched at pin 6 and pin 7, a voltage step at  $V_{IN}$  will cause a step change in  $f_{OUT}$ . If  $C_{IN}$  is much less than  $C_L$ , a step at  $V_{IN}$  may cause  $f_{OUT}$  to stop momentarily. A  $47\Omega$  resistor, in series with the  $1 \mu\text{F}$   $C_L$ , is added to give hysteresis effect which helps the input comparator provide the excellent linearity (0.03% typical).

### DETAIL OF OPERATION OF PRECISION V-TO-F CONVERTER (FIGURE 3)

In this circuit, integration is performed by using a conventional operational amplifier and feedback capacitor,  $C_F$ . When the integrator's output crosses the nominal threshold level at pin 6 of the LM131, the timing cycle is initiated.

The average current fed into the op amp's summing point (pin 2) is  $i \times (1.1 R_t C_t) \times f$  which is perfectly balanced with  $-V_{IN}/R_{IN}$ . In this circuit, the voltage offset of the LM131 input comparator does not affect the offset or accuracy of the V-to-F converter as it does in the stand-alone V-to-F converter; nor does the LM131 bias current or offset current. Instead, the offset voltage and offset current of the operational amplifier are the only limits on how small the signal can be accurately converted. Since op amps with voltage offset well below 1 mV and offset currents well below 2 nA are available at low cost, this circuit is recommended for best accuracy for small signals. This circuit also responds immediately to any change of input signal (which a stand-alone circuit does not) so that the output frequency will be an accurate representation of  $V_{IN}$ , as quickly as 2 output pulses' spacing can be measured.

In the precision mode, excellent linearity is obtained because the current source (pin 1) is always at ground potential and that voltage does not vary with  $V_{IN}$  or  $f_{OUT}$ . (In the stand-alone V-to-F converter, a major cause of non-linearity is the output impedance at pin 1 which causes  $i$  to change as a function of  $V_{IN}$ ).

The circuit of Figure 4 operates in the same way as Figure 3, but with the necessary changes for high speed operation.

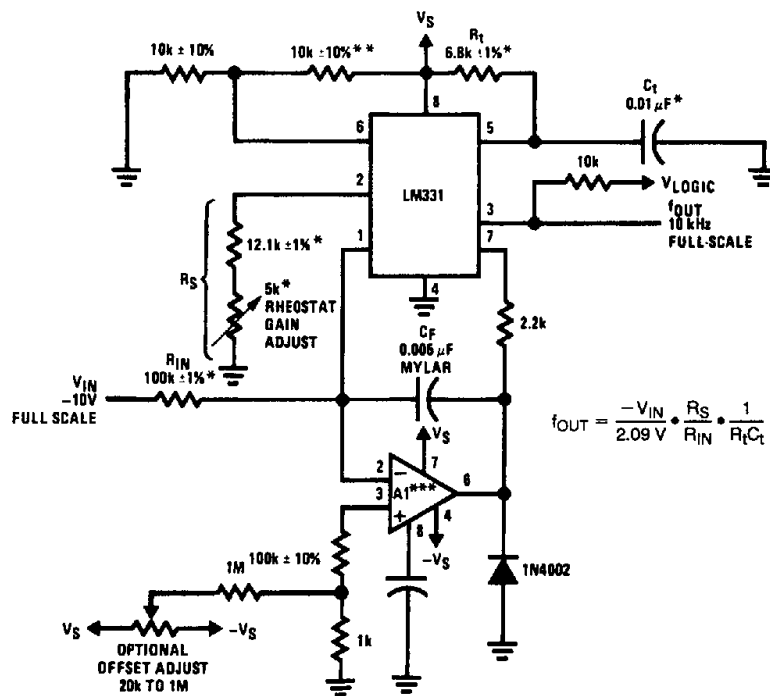

TL/H/5680-5

\*Use stable components with low temperature coefficients. See Typical Applications section.

\*\*This resistor can be 5 k $\Omega$  or 10 k $\Omega$  for  $V_S = 8\text{V}$  to 22V, but must be 10 k $\Omega$  for  $V_S = 4.5\text{V}$  to 8V.

\*\*\*Use low offset voltage and low offset current op amps for A1: recommended types LM108, LM308A, LF411A

FIGURE 3. Standard Test Circuit and Applications Circuit, Precision Voltage-to-Frequency Converter

LM131A/LM131/LM231A/LM231/LM331A/LM331

NATL SEMICOND (LINEAR)

Typical Applications (Continued)

DETAILS OF OPERATION, FREQUENCY-TO-VOLTAGE CONVERTERS (FIGURES 5 AND 6)

In these applications, a pulse input at  $f_{IN}$  is differentiated by a C-R network and the negative-going edge at pin 6 causes the input comparator to trigger the timer circuit. Just as with a V-to-F converter, the average current flowing out of pin 1 is  $I_{AVERAGE} = i \times (1.1 R_T C_T) \times f$ .

In the simple circuit of FIGURE 5, this current is filtered in the network  $R_L = 100 \text{ k}\Omega$  and  $1 \mu\text{F}$ . The ripple will be less than 10 mV peak, but the response will be slow, with a

0.1 second time constant, and settling of 0.7 second to 0.1% accuracy.

In the precision circuit, an operational amplifier provides a buffered output and also acts as a 2-pole filter. The ripple will be less than 5 mV peak for all frequencies above 1 kHz, and the response time will be much quicker than in FIGURE 5. However, for input frequencies below 200 Hz, this circuit will have worse ripple than FIGURE 5. The engineering of the filter time-constants to get adequate response and small enough ripple simply requires a study of the compromises to be made. Inherently, V-to-F converter response can be fast, but F-to-V response can not.

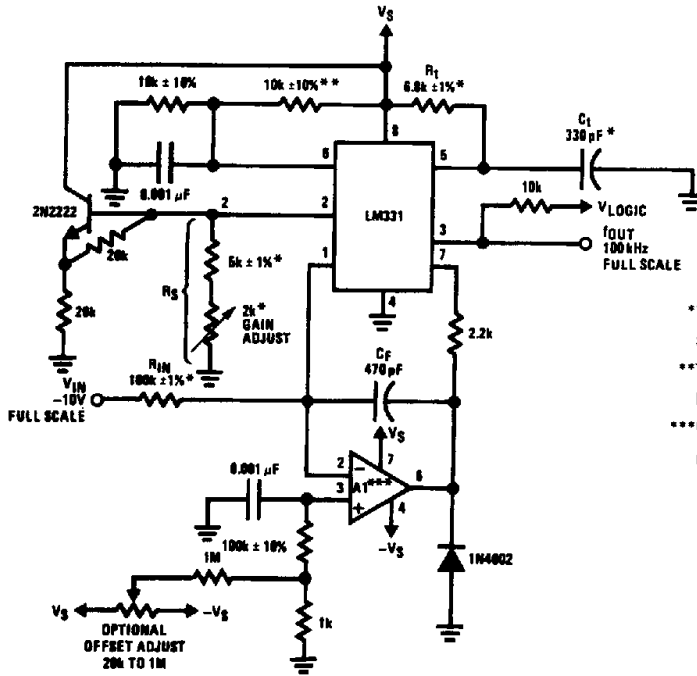

- \*Use stable components with low temperature coefficients. See Typical Applications section.
- \*\*This resistor can be 5 kΩ or 10 kΩ for  $V_S = 8\text{V}$  to 22V, but must be 10 kΩ for  $V_S = 4.5\text{V}$  to 8V.
- \*\*\*Use low offset voltage and low offset current op amps for A1: recommended types LF411A or LF356.

TL/H/5680-6  
**FIGURE 4. Precision Voltage-to-Frequency Converter, 100 kHz Full-Scale, ±0.03% Non-Linearity**

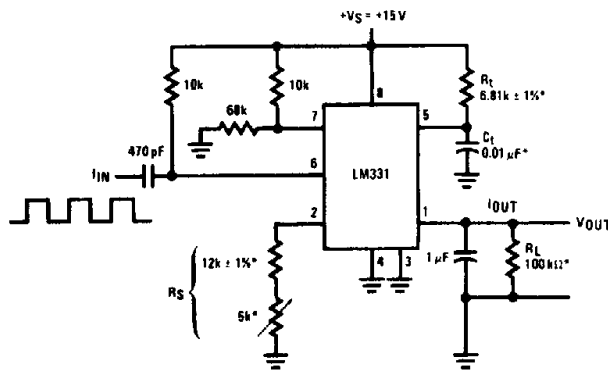

$$V_{OUT} = f_{IN} \times 2.09V \times \frac{R_L}{R_S} \times (R_T C_T)$$

\*Use stable components with low temperature coefficients.

**FIGURE 5. Simple Frequency-to-Voltage Converter, 10 kHz Full-Scale, ±0.06% Non-Linearity**

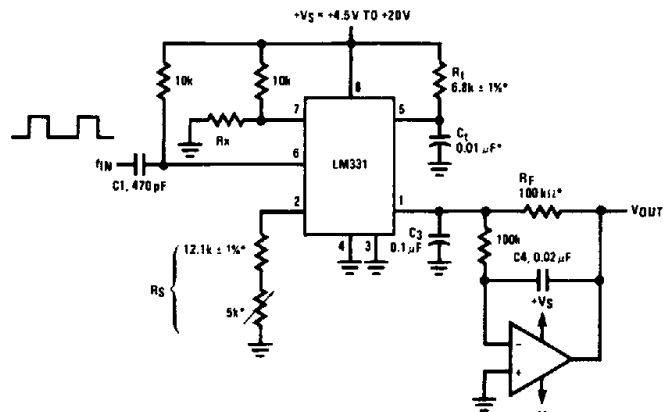

$$V_{OUT} = -f_{IN} \times 2.09V \times \frac{R_F}{R_S} \times (R_T C_T)$$

$$\text{SELECT } R_X = \frac{(V_S - 2V)}{0.2 \text{ mA}}$$

\*Use stable components with low temperature coefficients.

**FIGURE 6. Precision Frequency-to-Voltage Converter, 10 kHz Full-Scale with 2-Pole Filter, ±0.01% Non-Linearity Maximum**



Typical Applications (Continued)

Light Intensity to Frequency Converter

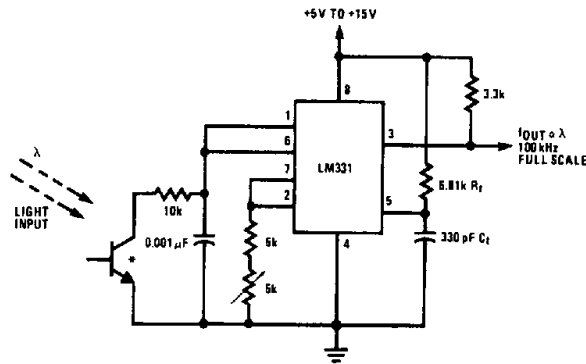

TL/H/5680-9

\*L14F-1, L14G-1 or L14H-1, photo transistor (General Electric Co.) or similar

Temperature to Frequency Converter

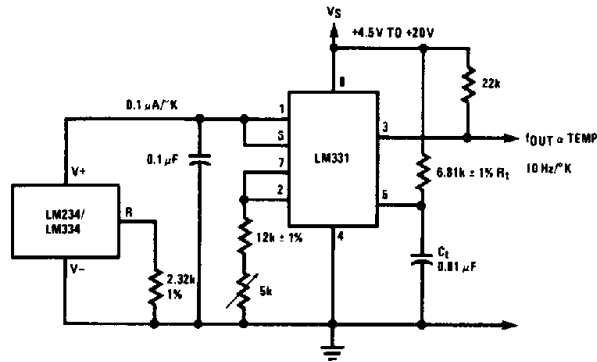

TL/H/5680-10

Long-Term Digital Integrator Using VFC

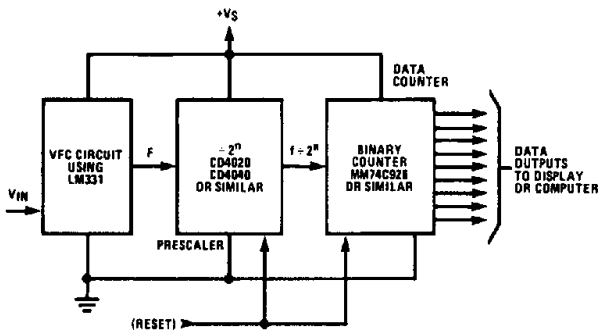

TL/H/5680-11

Basic Analog-to-Digital Converter Using Voltage-to-Frequency Converter

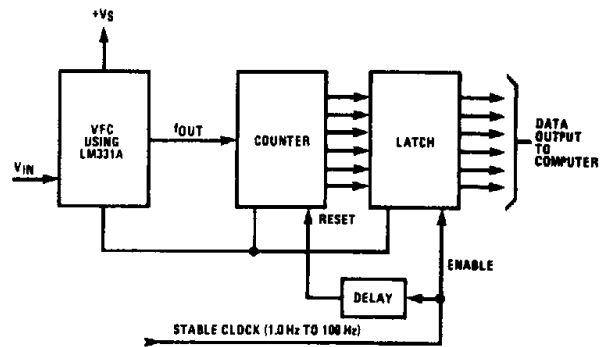

TL/H/5680-12

Typical Applications (Continued)

Analog-to-Digital Converter with Microprocessor

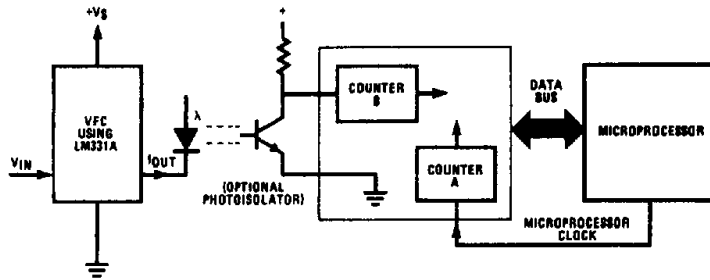

TL/H/5680-13

Remote Voltage-to-Frequency Converter with 2-Wire Transmitter and Receiver

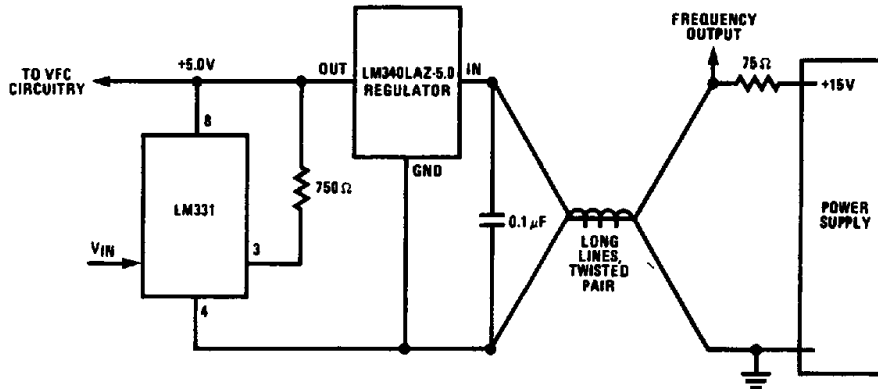

TL/H/5680-14

Voltage-to-Frequency Converter with Square-Wave Output Using  $\div 2$  Flip-Flop

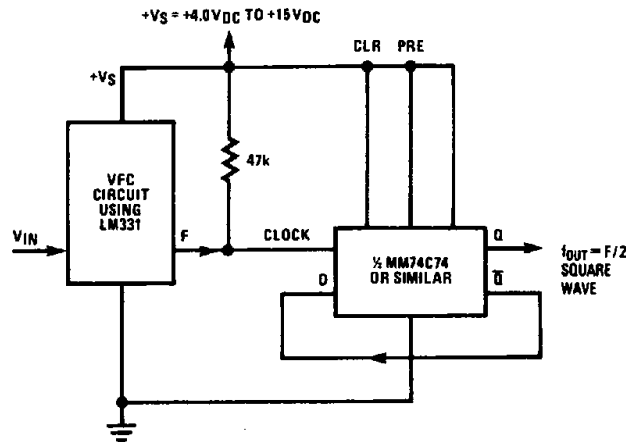

TL/H/5680-15

Voltage-to-Frequency Converter with Isolators

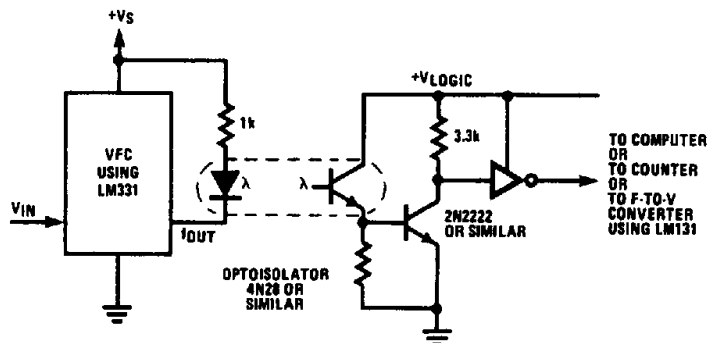

TL/H/5680-16

Typical Applications (Continued)

LM131A/LM131/LM231A/LM231/LM331A/LM331

Voltage-to-Frequency Converter with Isolators

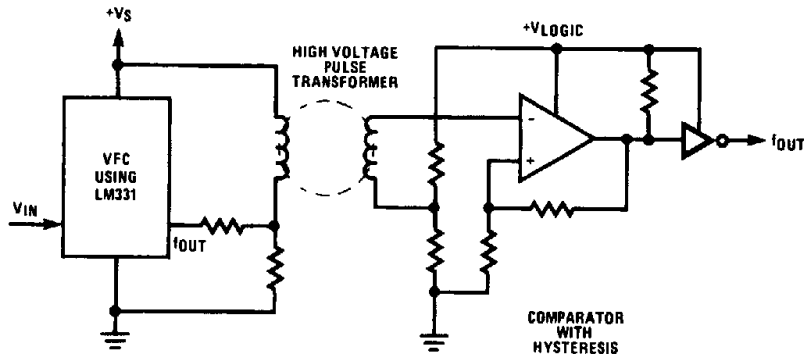

TL/H/5680-17

Voltage-to-Frequency Converter with Isolators

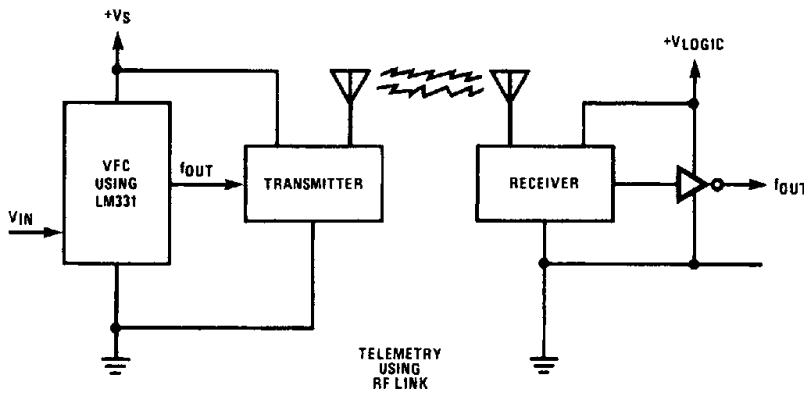

TL/H/5680-18

Voltage-to-Frequency Converter with Isolators

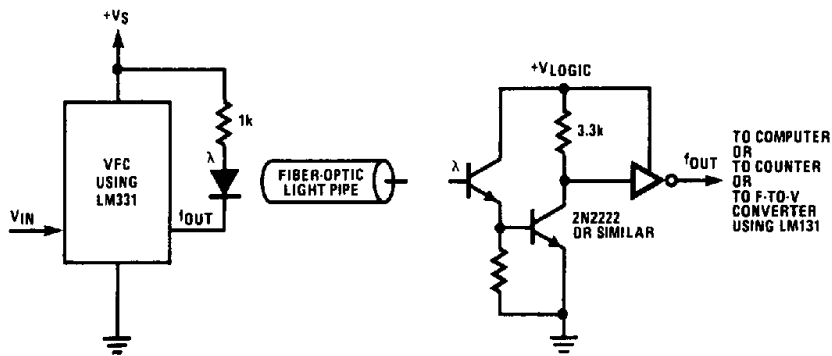

TL/H/5680-19

LM131A/LM131H/LM231A/LM231H/LM331A/LM331H

### Connection Diagrams

NATL SEMICOND (LINEAR)

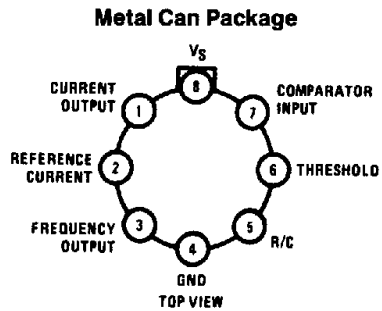

Note: Metal case is connected to pin 4 (GND.)

TL/H/5680-20

Order Number LM131AH, LM131H, LM231AH,  
LM231H, LM331AH or LM331H  
See NS Package Number H08C

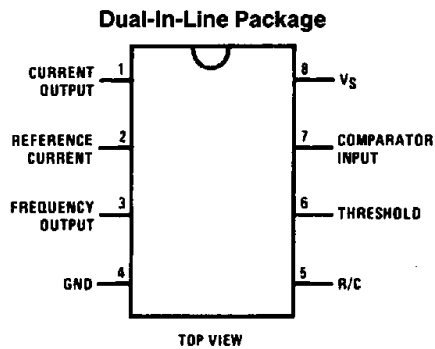

TL/H/5680-21

Order Number LM231AN, LM231N, LM331AN,  
or LM331N  
See NS Package Number N08E

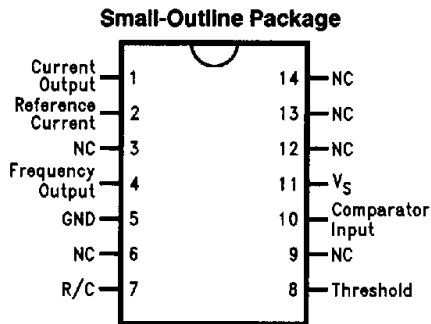

TL/H/5680-24

Order Number LM231WM  
See NS Package Number M14B

NATL SEMICOND (LINEAR)

Schematic Diagram

LM131A/LM131/LM231A/LM231/LM331A/LM331

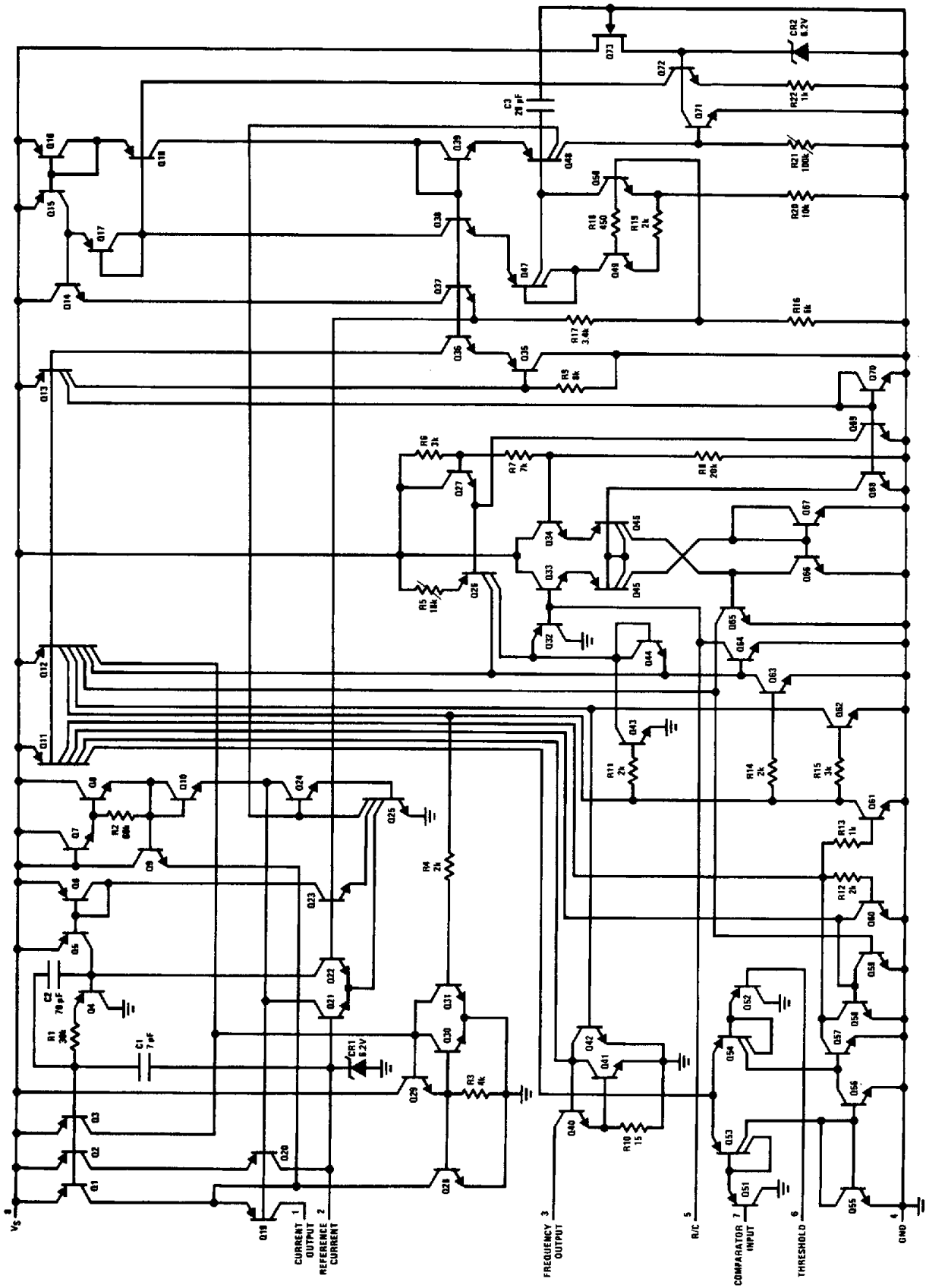

TL/H/5680-22