

## AD7741/AD7742

### FEATURES

- AD7741: One Single-Ended Input Channel**
- AD7742: Two Differential or Three Pseudo-Differential Input Channels**
- Integral Nonlinearity of 0.012% at  $f_{OUT}(\text{Max}) = 2.75 \text{ MHz}$  (AD7742) and at  $f_{OUT}(\text{Max}) = 1.35 \text{ MHz}$  (AD7741)**
- Single +5 V Supply Operation**
- Buffered Inputs**
- Programmable Gain Analog Front-End**
- On-Chip +2.5 V Reference**
- Internal/External Reference Option**
- Power Down to 35  $\mu\text{A}$  Max**
- Minimal External Components Required**
- 8-Lead and 16-Lead DIP and SOIC Packages**

### APPLICATIONS

- Low Cost Analog-to-Digital Conversion**
- Signal Isolation**

### GENERAL DESCRIPTION

The AD7741/AD7742 are a new generation of synchronous voltage-to-frequency converters (VFCs). The AD7741 is a single-channel version in an 8-lead package (SOIC/DIP) and the AD7742 is a multichannel version in a 16-lead package (SOIC/DIP). No user trimming is required to achieve the specified performance.

The AD7741 has a single buffered input whereas the AD7742 has four buffered inputs that may be configured as two fully-differential inputs or three pseudo-differential inputs. Both parts include an on-chip +2.5 V bandgap reference that provides the user with the option of using this internal reference or an external reference.

### FUNCTIONAL BLOCK DIAGRAMS

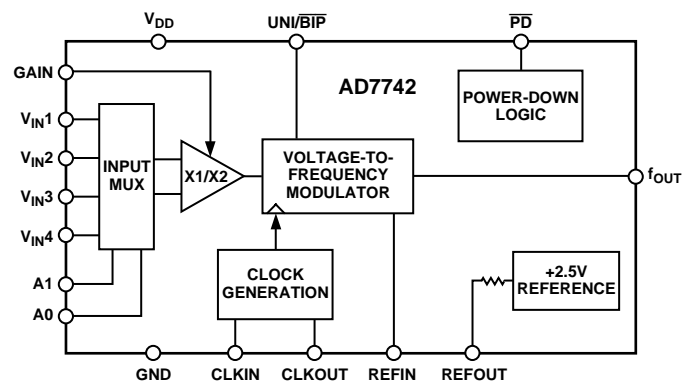
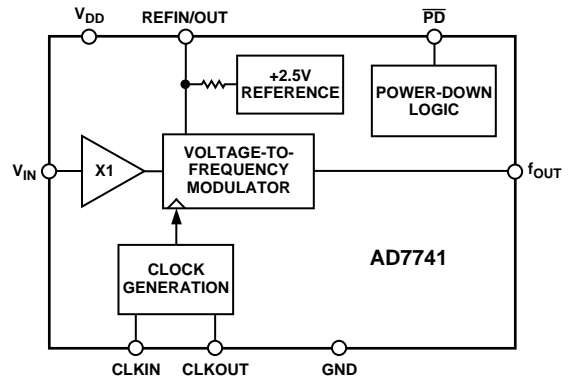

The AD7741 has a single-ended voltage input range from 0 V to REF<sub>IN</sub>. The AD7742 has a differential voltage input range from  $-V_{REF}$  to  $+V_{REF}$ . Both parts operate from a single +5 V supply consuming typically 6 mA, and also contain a power-down feature that reduces the current consumption to less than 35  $\mu\text{A}$ .

### REV. 0

Information furnished by Analog Devices is believed to be accurate and reliable. However, no responsibility is assumed by Analog Devices for its use, nor for any infringements of patents or other rights of third parties which may result from its use. No license is granted by implication or otherwise under any patent or patent rights of Analog Devices.

# AD7741—SPECIFICATIONS ( $V_{DD} = +4.75\text{ V to }+5.25\text{ V}$ ; $V_{REF} = +2.5\text{ V}$ ; $f_{CLKIN} = 6.144\text{ MHz}$ ; all specifications $T_{MIN}$ to $T_{MAX}$ unless otherwise noted.)

Parameter <sup>2</sup>	B and Y Version <sup>1</sup>			Units	Conditions/Comments
	Min	Typ	Max		
<b>DC PERFORMANCE</b>					
Integral Nonlinearity					$V_{DD} > 4.8\text{ V}$
$f_{CLKIN} = 200\text{ kHz}^3$			$\pm 0.012$	% of Span <sup>4</sup>	
$f_{CLKIN} = 3\text{ MHz}^3$			$\pm 0.012$	% of Span	
$f_{CLKIN} = 6.144\text{ MHz}$			$\pm 0.024$	% of Span	
Offset Error			$\pm 40$	mV	
Gain Error	0	+0.8	+1.6	% of Span	
Offset Error Drift <sup>3</sup>		$\pm 30$		$\mu\text{V}/^\circ\text{C}$	$\Delta V_{DD} = \pm 5\%$
Gain Error Drift <sup>3</sup>		$\pm 16$		ppm of Span/ $^\circ\text{C}$	
Power Supply Rejection Ratio <sup>3</sup>		-63		dB	
<b>ANALOG INPUT<sup>5</sup></b>					
Input Current		$\pm 50$	$\pm 100$	nA	
Input Voltage Range	0		$V_{REF}$	V	
<b>+2.5 V REFERENCE (REFIN/OUT)</b>					
<b>REFIN</b>					
Nominal Input Voltage		2.5		V	
Input Impedance <sup>6</sup>		N/A			
<b>REFOUT</b>					
Output Voltage	2.38	2.50	2.60	V	
Output Impedance <sup>3</sup>		1		k $\Omega$	
Reference Drift <sup>3</sup>		$\pm 50$		ppm/ $^\circ\text{C}$	
Line Rejection		-60		dB	
Reference Noise (0.1 Hz to 10 Hz) <sup>3</sup>		100		$\mu\text{V p-p}$	
<b>LOGIC OUTPUT</b>					
Output High Voltage, $V_{OH}$	4.0			V	Output Sourcing 800 $\mu\text{A}^7$ Output Sinking 1.6 mA <sup>7</sup> $V_{IN} = 0\text{ V}$ $V_{IN} = V_{REF}$
Output Low Voltage, $V_{OL}$			0.4	V	
Minimum Output Frequency		$0.05 f_{CLKIN}$		Hz	
Maximum Output Frequency		$0.45 f_{CLKIN}$		Hz	
<b>LOGIC INPUT</b>					
<b><math>\overline{\text{PD}}</math> ONLY</b>					
Input High Voltage, $V_{IH}$	2.4			V	
Input Low Voltage, $V_{IL}$			0.8	V	
Input Current			$\pm 100$	nA	
Pin Capacitance		6	10	pF	
<b>CLKIN ONLY</b>					
Input High Voltage, $V_{IH}$	3.5			V	
Input Low Voltage, $V_{IL}$			0.8	V	
Input Current			$\pm 2$	$\mu\text{A}$	
Pin Capacitance		6	10	pF	
<b>CLOCK FREQUENCY</b>					
Input Frequency			6.144	MHz	For Specified Performance
<b>POWER REQUIREMENTS</b>					
$V_{DD}$	4.75		5.25	V	Output Unloaded
$I_{DD}$ (Normal Mode)			8	mA	
$I_{DD}$ (Power-Down)		15	35	$\mu\text{A}$	Coming Out of Power-Down Mode
Power-Up Time <sup>3</sup>		30		$\mu\text{s}$	

## NOTES

<sup>1</sup>Temperature ranges: B Version -40°C to +85°C; Y Version: -40°C to +105°C.

<sup>2</sup>See Terminology.

<sup>3</sup>Guaranteed by design and characterization, not production tested.

<sup>4</sup>Span = Maximum Output Frequency - Minimum Output Frequency.

<sup>5</sup>The absolute voltage on the input pin must not go more positive than  $V_{DD} - 2.25\text{ V}$  or more negative than GND.

<sup>6</sup>Because this pin is bidirectional, any external reference must be capable of sinking/sourcing 400  $\mu\text{A}$  in order to overdrive the internal reference.

<sup>7</sup>These logic levels apply to CLKOUT only when it is loaded with one CMOS load.

Specifications subject to change without notice.

# AD7742—SPECIFICATIONS ( $V_{DD} = +4.75\text{ V to }+5.25\text{ V}$ ; $V_{REF} = +2.5\text{ V}$ ; $f_{CLKIN} = 6.144\text{ MHz}$ ; all specifications $T_{MIN}$ to $T_{MAX}$ unless otherwise noted.)

Parameter <sup>3</sup>	B Version <sup>1</sup>			Y Version <sup>2</sup>			Units	Conditions/Comments
	Min	Typ	Max	Min	Typ	Max		
<b>DC PERFORMANCE</b>								
Integral Nonlinearity								
$f_{CLKIN} = 200\text{ kHz}^4$			$\pm 0.0122$			$\pm 0.015$	% of Span <sup>5</sup>	
$f_{CLKIN} = 3\text{ MHz}^4$			$\pm 0.0122$			$\pm 0.015$	% of Span	
$f_{CLKIN} = 6.144\text{ MHz}$			$\pm 0.0122$			$\pm 0.015$	% of Span	
Offset Error			$\pm 40$			$\pm 40$	mV	Unipolar Mode
			$\pm 40$			$\pm 40$	mV	Bipolar Mode
Gain Error	+0.2	+1.2	+2.2	+0.2	+1.2	+2.2	% of Span	Unipolar Mode
	+0.2	+1.2	+2.2	+0.2	+1.2	+2.2	% of Span	Bipolar Mode
Offset Error Drift <sup>4</sup>		$\pm 12$			$\pm 12$		$\mu\text{V}/^\circ\text{C}$	Unipolar Mode
		$\pm 12$			$\pm 12$		$\mu\text{V}/^\circ\text{C}$	Bipolar Mode
Gain Error Drift <sup>4</sup>		$\pm 2$			$\pm 2$		ppm of Span/ $^\circ\text{C}$	Unipolar Mode
		$\pm 4$			$\pm 4$		ppm of Span/ $^\circ\text{C}$	Bipolar Mode
Power Supply Rejection Ratio <sup>4</sup>		-70			-70		dB	$\Delta V_{DD} = \pm 5\%$
Channel-to-Channel Isolation <sup>4</sup>		-75			-75		dB	
Common-Mode Rejection	-60	-78		-58	-78		dB	
<b>ANALOG INPUTS (<math>V_{IN1}</math>–<math>V_{IN4}</math>)<sup>6</sup></b>								
Input Current		$\pm 50$	$\pm 100$		$\pm 50$	$\pm 100$	nA	
Common-Mode Input Range	+0.5		$V_{DD} - 1.75$	+0.5		$V_{DD} - 1.75$	V	Bipolar Mode
	$-V_{REF}/\text{Gain}$		$+V_{REF}/\text{Gain}$	$-V_{REF}/\text{Gain}$		$+V_{REF}/\text{Gain}$	V	
Differential Input Range	0		$+V_{REF}/\text{Gain}$	0		$+V_{REF}/\text{Gain}$	V	Unipolar Mode
<b>VOLTAGE REFERENCE</b>								
<b>REFIN</b>								
Nominal Input Voltage		2.5			2.5		V	
Input Impedance <sup>4</sup>							k $\Omega$	
$f_{CLKIN} = 3\text{ MHz}$	70			70			k $\Omega$	
$f_{CLKIN} = 6.144\text{ MHz}$	35			35			k $\Omega$	
<b>REFOUT</b>								
Output Voltage	2.38	2.50	2.60	2.38	2.50	2.60	V	
Output Impedance <sup>4</sup>		1			1		k $\Omega$	
Reference Drift <sup>4</sup>		$\pm 50$			$\pm 50$		ppm/ $^\circ\text{C}$	
Line Rejection		-70			-70		dB	
Reference Noise (0.1 Hz to 10 Hz) <sup>4</sup>		100			100		$\mu\text{V p-p}$	
<b>LOGIC OUTPUT</b>								
Output High Voltage, $V_{OH}$	4.0			4.0			V	Output Sourcing 800 $\mu\text{A}$ <sup>7</sup>
Output Low Voltage, $V_{OL}$			0.4			0.4	V	Output Sinking 1.6 mA <sup>7</sup>
Minimum Output Frequency		$0.05 f_{CLKIN}$			$0.05 f_{CLKIN}$		Hz	$V_{IN} = 0\text{ V}$ (Unipolar), $V_{IN} = -V_{REF}/\text{Gain}$ (Bipolar)
Maximum Output Frequency		$0.45 f_{CLKIN}$			$0.45 f_{CLKIN}$		Hz	$V_{IN} = V_{REF}/\text{Gain}$ (Unipolar and Bipolar)
<b>LOGIC INPUT</b>								
<b>ALL EXCEPT CLKIN</b>								
Input High Voltage, $V_{IH}$	2.4			2.4			V	
Input Low Voltage, $V_{IL}$			0.8			0.8	V	
Input Current			$\pm 100$			$\pm 100$	nA	
Pin Capacitance		6	10		6	10	pF	
<b>CLKIN ONLY</b>								
Input High Voltage, $V_{IH}$	3.5			3.5			V	
Input Low Voltage, $V_{IL}$			0.8			0.8	V	
Input Current			$\pm 2$			$\pm 2$	$\mu\text{A}$	
Pin Capacitance		6	10		6	10	pF	
<b>CLOCK FREQUENCY</b>								
Input Frequency			6.144			6.144	MHz	For Specified Performance
<b>POWER REQUIREMENTS</b>								
$V_{DD}$	4.75		5.25	4.75		5.25	V	
$I_{DD}$ (Normal Mode)		6	8		6	8	mA	Output Unloaded
$I_{DD}$ (Power-Down)		25	35		25	35	$\mu\text{A}$	
Power-Up Time <sup>4</sup>		30			30		$\mu\text{s}$	Coming Out of Power-Down Mode

**NOTES**<sup>1</sup>Temperature range: B Version:  $-40^\circ\text{C}$  to  $+85^\circ\text{C}$ .<sup>2</sup>Temperature range: Y Version:  $-40^\circ\text{C}$  to  $+105^\circ\text{C}$ .<sup>3</sup>See Terminology.<sup>4</sup>Guaranteed by design and characterization, not production tested.<sup>5</sup>Span = Maximum Output Frequency–Minimum Output Frequency.<sup>6</sup>The absolute voltage on the input pins must not go more positive than  $V_{DD} - 1.75\text{ V}$  or more negative than  $+0.5\text{ V}$ .<sup>7</sup>These logic levels apply to CLKOUT only when it is loaded with one CMOS load.

Specifications subject to change without notice.

# AD7741/AD7742

## TIMING CHARACTERISTICS<sup>1, 2, 3</sup> ( $V_{DD} = +4.75 \text{ V to } +5.25 \text{ V}$ ; $V_{REF} = +2.5 \text{ V}$ . All specifications $T_{MIN}$ to $T_{MAX}$ unless otherwise noted.)

Parameter	Limit at $T_{MIN}$ , $T_{MAX}$ (B and Y Version)	Units	Conditions/Comments
$f_{CLKIN}$	6.144	MHz max	Input Clock Mark/Space Ratio
$t_{HIGH}/t_{LOW}$	55/45	max	
	45/55	min	
$t_1$	9	ns typ	$f_{CLOCK}$ Rising Edge to $f_{OUT}$ Rising Edge
$t_2$	4	ns typ	$f_{OUT}$ Rise Time
$t_3$	4	ns typ	$f_{OUT}$ Fall Time
$t_4$	$t_{HIGH} \pm 5$	ns typ	$f_{OUT}$ Pulsewidth

### NOTES

<sup>1</sup>Guaranteed by design and characterization, not production tested.

<sup>2</sup>All input signals are specified with  $t_r = t_f = 5 \text{ ns}$  (10% to 90% of  $V_{DD}$ ) and timed from a voltage level of  $(V_{IL} + V_{IH})/2$ .

<sup>3</sup>See Figure 1.

Specifications subject to change without notice.

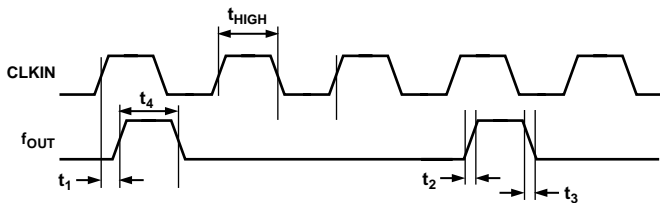

Figure 1. Timing Diagram

### ORDERING GUIDE

Models	Temperature Ranges	Package Descriptions	Package Options
AD7741BN	-40°C to +85°C	Plastic DIP	N-8
AD7741BR	-40°C to +85°C	Small Outline	R-8
AD7741YR	-40°C to +105°C	Small Outline	R-8
AD7742BN	-40°C to +85°C	Plastic DIP	N-16
AD7742BR	-40°C to +85°C	Small Outline	R-16A
AD7742YR	-40°C to +105°C	Small Outline	R-16A

### ABSOLUTE MAXIMUM RATINGS<sup>1, 2</sup>

( $T_A = +25^\circ\text{C}$  unless otherwise noted)

$V_{DD}$ to GND	-0.3 V to +7 V
Analog Input Voltage to GND	-5 V to $V_{DD} + 0.3 \text{ V}$
Digital Input Voltage to GND	-0.3 V to $V_{DD} + 0.3 \text{ V}$
Reference Input Voltage to GND	-0.3 V to $V_{DD} + 0.3 \text{ V}$
$f_{OUT}$ to GND	-0.3 V to $V_{DD} + 0.3 \text{ V}$
Operating Temperature Range	
Automotive (Y Version)	-40°C to +105°C
Industrial (B Version)	-40°C to +85°C
Storage Temperature Range	-65°C to +150°C
Junction Temperature	+150°C
Plastic DIP Package	
Power Dissipation	450 mW
$\theta_{JA}$ Thermal Impedance (8 Lead)	125°C/W
$\theta_{JA}$ Thermal Impedance (16 Lead)	117°C/W
Lead Temperature, Soldering	
Vapor Phase (60 sec)	+215°C
Infrared (15 sec)	+220°C
SOIC Package	
Power Dissipation	450 mW
$\theta_{JA}$ Thermal Impedance (8 Lead)	157°C/W
$\theta_{JA}$ Thermal Impedance (16 Lead)	125°C/W
Lead Temperature, Soldering	
Vapor Phase (60 sec)	+215°C
Infrared (15 sec)	+220°C

### NOTES

<sup>1</sup>Stresses above those listed under Absolute Maximum Ratings may cause permanent damage to the device. This is a stress rating only; functional operation of the device at these or any other conditions above those listed in the operational sections of this specification is not implied. Exposure to absolute maximum rating conditions for extended periods may affect device reliability.

<sup>2</sup>Transient currents of up to 100 mA will not cause SCR latch-up.

### CAUTION

ESD (electrostatic discharge) sensitive device. Electrostatic charges as high as 4000 V readily accumulate on the human body and test equipment and can discharge without detection. Although the AD7741/AD7742 features proprietary ESD protection circuitry, permanent damage may occur on devices subjected to high energy electrostatic discharges. Therefore, proper ESD precautions are recommended to avoid performance degradation or loss of functionality.



## AD7741 PIN FUNCTION DESCRIPTION

Pin No.	Mnemonic	Function
1	V <sub>DD</sub>	Power Supply Input. These parts can be operated from +4.75 V to +5.25 V and the supply should be adequately decoupled to GND.
2	GND	Ground reference point for all circuitry on the part.
3	CLKOUT	External Clock Output. When the master clock for the device is a crystal, the crystal is connected between CLKIN and CLKOUT. When an external clock is applied to CLKIN, the CLKOUT pin provides an inverted clock signal. This clock should be buffered if it is to be used as a clock source elsewhere in the system.
4	CLKIN	External Clock Input. The master clock for the device can be provided in the form of a crystal or an external clock. A crystal may be tied across the CLKIN and CLKOUT pins. Alternatively, the CLKIN pin may be driven by a CMOS-compatible clock and CLKOUT left unconnected. The frequency of the master clock may be as high as 6 MHz.
5	REFIN/OUT	This is the reference input to the core of the VFC and defines the span of the VFC. If this pin is left unconnected, the internal 2.5 V reference is used. Alternatively, a precision external reference (e.g., REF192) may be used to overdrive the internal reference. The internal bandgap reference has a high output impedance in order to allow it to be overdriven.
6	V <sub>IN</sub>	The analog input to the VFC. It has an input range from 0 V to V <sub>REF</sub> . This input is buffered so it draws virtually no current from whatever source is driving it.
7	$\overline{\text{PD}}$	Active Low Power-Down pin. When this input is low, the part enters power-down mode where it typically consumes 15 $\mu\text{A}$ of current.
8	f <sub>OUT</sub>	Frequency Output. This pin provides the output of the synchronous VFC.

## PIN CONFIGURATION

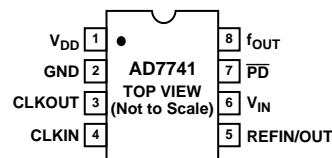

# AD7741/AD7742

## AD7742 PIN FUNCTION DESCRIPTION

Pin No.	Mnemonic	Function
1	$f_{OUT}$	Frequency Output. This pin provides the output of the synchronous VFC.
2	$V_{DD}$	Power Supply Input. These parts can be operated from +4.75 V to +5.25 V and the supply should be adequately decoupled to GND.
3	GND	Ground reference point for all circuitry on the part.
4–5	A1, A0	Address Inputs used to select the input channel configuration.
6	CLKOUT	External Clock Output. When the master clock for the device is a crystal, the crystal is connected between CLKIN and CLKOUT. When an external clock is applied to CLKIN, the CLKOUT pin provides an inverted clock signal. This clock should be buffered if it is to be used as a clock source elsewhere in the system.
7	CLKIN	External Clock Input. The master clock for the device can be provided in the form of a crystal or an external clock. A crystal may be tied across the CLKIN and CLKOUT pins. Alternatively, the CLKIN pin may be driven by a CMOS-compatible clock and CLKOUT left unconnected. The frequency of the master clock may be as high as 6 MHz.
8	$\overline{UNI/BIP}$	Control input which determines whether the device operates with differential bipolar analog input signals or differential unipolar analog input signals.
9	REFOUT	2.5 V Voltage Reference Output. This can be tied directly to REFIN. It may also be used as a reference to other parts of the system provided it is buffered first.
10	REFIN	This is the Reference Input to the core of the VFC and defines the span of the VFC. A 2.5 V reference is required at this pin. This may be provided by connecting it directly to REFOUT or by using a precision external reference (e.g., REF192).
11	$V_{IN1}$	Buffered Analog Input Channel 1. This is either a pseudo-differential input with respect to $V_{IN4}$ or it is the positive input of a truly-differential input pair with respect to $V_{IN2}$ .
12	$V_{IN2}$	Buffered Analog Input Channel 2. This is either a pseudo-differential input with respect to $V_{IN4}$ or it is the negative input of a truly-differential input pair with respect to $V_{IN1}$ .
13	$V_{IN3}$	Buffered Analog Input Channel 3. This is the positive input of a truly-differential input pair with respect to $V_{IN4}$ .
14	$V_{IN4}$	Buffered Analog Input Channel 4. This is either the common for pseudo-differential input with respect to $V_{IN1}$ or $V_{IN2}$ or it is the negative input of a truly-differential input pair with respect to $V_{IN3}$ .
15	GAIN	Gain Select input that controls whether the gain on the analog front-end is X1 or X2.
16	$\overline{PD}$	Active Low Power-Down pin. When this input is low, the part enters power-down mode where it typically consumes 25 $\mu$ A of current.

### PIN CONFIGURATION

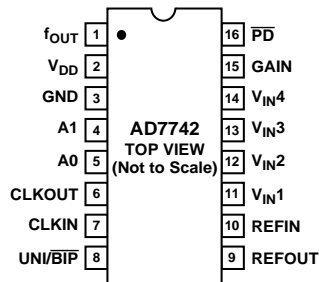

**TERMINOLOGY****INTEGRAL NONLINEARITY**

For the VFC, Integral Nonlinearity (INL) is a measure of the maximum deviation from a straight line passing through the actual endpoints of the VFC transfer function. The error is expressed in % of the frequency span:

$$\text{Frequency Span} = f_{OUT(max)} - f_{OUT(min)}$$

**OFFSET ERROR**

This is a measure of the offset error of the VFC. Ideally, the minimum output frequency (corresponding to minimum input voltage) is 5% of  $f_{CLKIN}$ . The deviation from this value is the offset error. It is expressed in terms of the error referred to the input voltage. It is expressed in mV.

**GAIN ERROR**

This is a measure of the span error of the VFC. The gain is the scale factor that relates the input  $V_{IN}$  to the output  $f_{OUT}$ . The gain error is the deviation in slope of the actual VFC transfer characteristic from the ideal expressed as a percentage of the full-scale span.

**OFFSET ERROR DRIFT**

This is a measure of the change in Offset Error with changes in temperature. It is expressed in  $\mu V/^{\circ}C$ .

**GAIN ERROR DRIFT**

This is a measure of the change in Gain Error with changes in temperature. It is expressed in  $(\text{ppm of span})/^{\circ}C$ .

**POWER-SUPPLY REJECTION RATIO (PSRR)**

This indicates how the output of the VFC is affected by changes in the supply voltage. Again, this error is referred to the input voltage. The input voltage is kept constant and the  $V_{DD}$  supply is varied  $\pm 5\%$ . The ratio of the apparent change in input voltage to the change in  $V_{DD}$  is measured in dBs.

**CHANNEL-TO-CHANNEL ISOLATION**

This is a ratio of the amplitude of the signal at the input of one channel to a sine wave on the input of another channel. It is measured in dBs.

**COMMON-MODE REJECTION**

For the AD7742, the output frequency should remain unchanged provided the differential input remains unchanged although its common-mode level may change. The CMR is the ratio of the apparent change in differential input voltage to the actual change in common-mode voltage. It is expressed in dBs.

**GENERAL DESCRIPTION**

The AD7741/AD7742 are a new generation of CMOS synchronous Voltage-to-Frequency Converters (VFCs) that use a charge-balance conversion technique. The AD7741 is a single-channel version and the AD7742 is a multichannel version. The input voltage signal is applied to a proprietary programmable gain front-end based around an analog modulator that converts the input voltage into an output pulse train.

The parts also contain an on-chip +2.5 V bandgap reference and operate from a single +5 V supply. A block diagram of the AD7742 is shown in Figure 2.

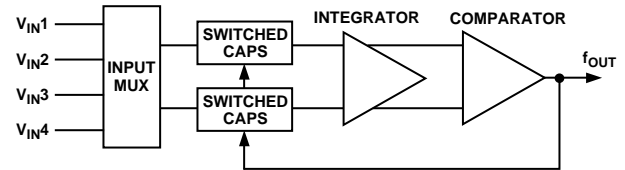

Figure 2. AD7742 Block Diagram

**Input Amplifier Stage**

The buffered input stage for the analog inputs presents a high impedance, allowing significant external source impedances. The four analog inputs ( $V_{IN1}$  through  $V_{IN4}$ ) each have a voltage range from +0.5 V to  $V_{DD} - 1.75$  V. This is an absolute voltage range and is relative to the GND pin.

In the case of the AD7742 multichannel part, a differential multiplexer switches one of the differential input channels to the VFC modulator. The multiplexer is controlled by two pins, A1 and A0. See Table I for channel configurations.

Table I. AD7742 Input Channel Selection

A1	A0	$V_{IN}(+)$	$V_{IN}(-)$	Type
0	0	$V_{IN1}$	$V_{IN4}$	Pseudo Differential
0	1	$V_{IN2}$	$V_{IN4}$	Pseudo Differential
1	0	$V_{IN3}$	$V_{IN4}$	Full Differential
1	1	$V_{IN1}$	$V_{IN2}$	Full Differential

**Analog Input Ranges**

The AD7741 has a unipolar single-ended input channel whereas the AD7742 contains four input channels which may be configured as two fully differential channels or as three pseudo-differential channels. The AD7742 also has a X1/X2 gain option on the front end. The channel and gain settings are pin-programmable.

The AD7742 uses differential inputs to provide common-mode noise rejection (i.e., the converted result will correspond to the differential voltage between the two inputs). The absolute voltage on both inputs must lie between +0.5 V and  $V_{DD} - 1.75$  V.



# AD7741/AD7742

**Table II. AD7741/AD7742 Input Range Selection**

UNI/BIP	GAIN	Gain, G	$V_{IN}(\text{Min})$ $f_{OUT} = 0.05 f_{CLKIN}$	$V_{IN}(\text{Max})$ $f_{OUT} = 0.45 f_{CLKIN}$	Part
N/A	N/A	X1	0	$+V_{REF}$	AD7741
0	0	X1	$-V_{REF}$	$+V_{REF}$	AD7742
0	1	X2	$-V_{REF}/2$	$+V_{REF}/2$	AD7742
1	0	X1	0	$+V_{REF}$	AD7742
1	1	X2	0	$+V_{REF}/2$	AD7742

As can be seen from Table II, the AD7741 has one input range configuration whereas the AD7742 has unipolar/bipolar as well as gain options depending on the status of the GAIN and UNI/BIP pins.

The transfer function for the AD7741 is shown in Figure 3. Figure 4 shows the AD7742 transfer function for unipolar input range configuration while the AD7742 transfer function for bipolar input range configuration is shown in Figure 5.

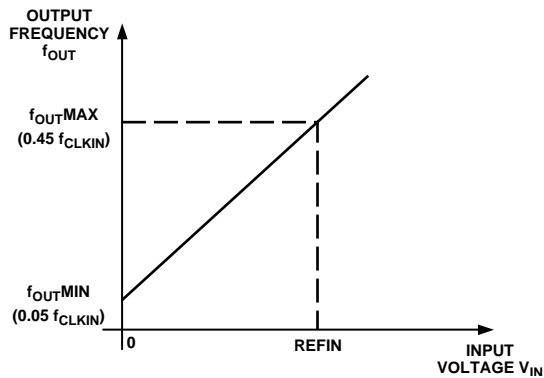

Figure 3. AD7741 Transfer Characteristic for Input Range from 0 to  $V_{REF}$

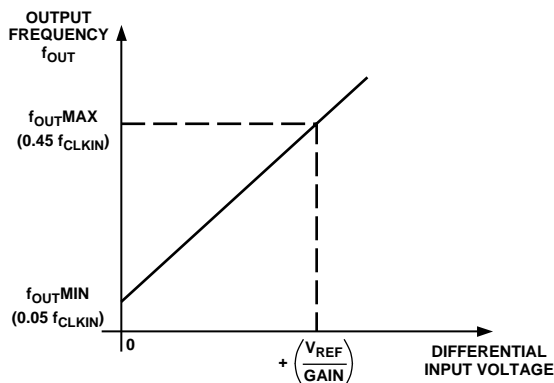

Figure 4. AD7742 Transfer Characteristic for Unipolar Differential Input Range: 0 V to  $V_{REF}/\text{Gain}$ ; the input common-mode range must be between  $+0.5\text{ V}$  and  $V_{DD} - 1.75\text{ V}$ . UNI/BIP pin tied to  $V_{DD}$ .

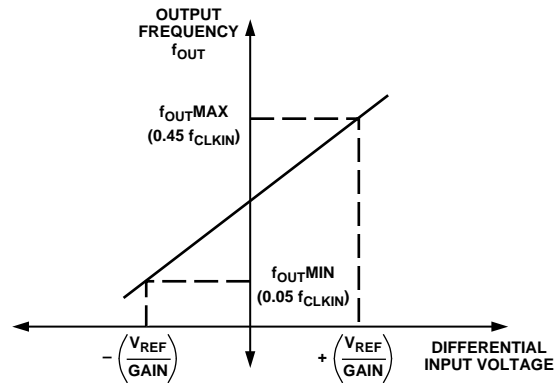

Figure 5. AD7742 Transfer Characteristic for Bipolar Differential Input Range:  $-V_{REF}/\text{Gain}$  to  $+V_{REF}/\text{Gain}$ ; the common-mode range must be between  $+0.5\text{ V}$  and  $V_{DD} - 1.75\text{ V}$ . UNI/BIP pin tied to GND.

### VFC Modulator

The analog input signal to the AD7741/AD7742 is continuously sampled by a switched capacitor modulator whose sampling rate is set by a master clock input that may be supplied externally or by a crystal-controlled on-chip clock oscillator. However, the input signal is buffered on-chip before being applied to the sampling capacitor of the modulator. This isolates the sampling capacitor charging currents from the analog input pins.

This system is a negative feedback loop that tries to keep the net charge on the integrator capacitor at zero, by balancing charge injected by the input voltage with charge injected by the  $V_{REF}$ . The output of the comparator provides the digital input for the 1-bit DAC, so that the system functions as a negative feedback loop that tries to minimize the difference signal (see Figure 6).

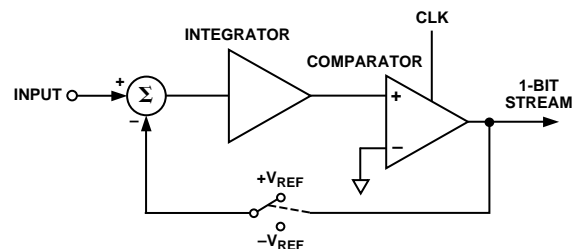

Figure 6. AD7741/AD7742 Modulator Loop



The digital data that represents the analog input voltage is contained in the duty cycle of the pulse train appearing at the output of the comparator. The output is a fixed-width pulse whose frequency depends on the analog input signal. The input voltage is offset internally so that a full-scale input gives an output frequency of  $0.45 f_{\text{CLKIN}}$  and zero-scale input gives an output frequency of  $0.05 f_{\text{CLKIN}}$ . The output allows simple interfacing to either standard logic families or opto-couplers. The clock high period controls the pulsewidth of the frequency output. The pulse is initiated by the edge of the clock signal. The delay time between the edge of the clock and the edge of the frequency output is typically 9 ns. Figure 7 shows the waveform of this frequency output.

After power-up, or if there is a step change in input voltage, there is a settling time that must elapse before valid data is obtained. This is typically 2 CLKIN cycles on the AD7742 and 10 CLKIN cycles on the AD7741.

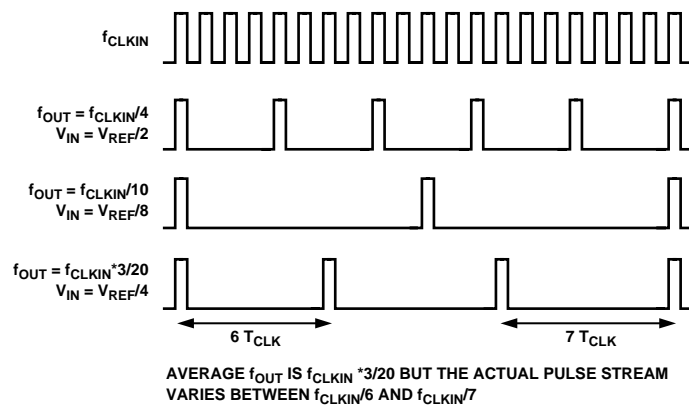

Figure 7. AD7741/AD7742 Frequency Output Waveforms

#### Clock Generation

As distinct from the asynchronous VFCs which rely on the stability of an external capacitor to set their full-scale frequency, the AD7741/AD7742 uses an external clock to define the full-scale output frequency. The result is a more stable, more linear transfer function and also allows the designer to determine the system stability and drift based upon the external clock selected. A crystal oscillator may also be used if desired.

The AD7741/AD7742 requires a master clock input, which may be an external CMOS-compatible clock signal applied to the CLKIN pin (CLKOUT not used). Alternatively, a crystal of the correct frequency can be connected between CLKIN and CLKOUT, when the clock circuit will function as a crystal controlled oscillator. Figure 8 shows a simple model of the on-chip oscillator.

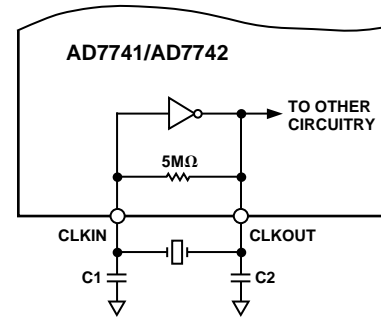

Figure 8. On-Chip Oscillator

The on-chip oscillator circuit also has a start-up time associated with it before it oscillates at its correct frequency and correct voltage levels. The typical start-up time for the circuit is 5 ms (with a 6.144 MHz crystal).

The AD7741/AD7742 master clock appears on the CLKOUT pin of the device. The maximum recommended load on this pin is one CMOS load. When using a crystal to generate the AD7741/AD7742 clock it may be desirable to then use this clock as the clock source for the system. In this case it is recommended that the CLKOUT signal be buffered with a CMOS buffer before being applied to the rest of the circuit.

#### Reference Input

The AD7741/AD7742 performs conversion relative to an applied reference voltage that allows easy interfacing to ratiometric systems. This reference may be applied using the internal 2.5 V bandgap reference. For the AD7741, this is done by simply leaving REFIN/OUT unconnected. For the AD7742, REFIN is tied to REFOUT. Alternatively, an external reference, e.g., REF192 or AD780, may be used. For the AD7741, this is connected to REFIN/OUT and will overdrive the internal reference. For the AD7742, it is connected directly to the REFIN pin.

While the internal reference will be adequate for most applications, power supply rejection and overall regulation may be improved through the use of an external precision reference. The process of selecting an external voltage reference should include consideration of drive capability, initial error, noise and drift characteristics. A suitable choice would be the AD780 or REF192.

#### Power-Down Mode

The low power standby mode is initiated by taking the  $\overline{\text{PD}}$  pin low, which shuts down most of the analog and digital circuitry. This reduces the power consumption to 185  $\mu\text{W}$  max.

# AD7741/AD7742

## APPLICATIONS

The basic connection diagram for the part is shown in Figure 9. In the connection diagram shown, the AD7742 analog inputs are configured as fully differential, bipolar inputs with a gain of 1. A quartz crystal provides the master clock source for the part. It may be necessary to connect capacitors (C1 and C2 in the diagram) on the crystal to ensure that it does not oscillate at overtones of its fundamental operating frequency. The values of capacitors will vary depending on the manufacturer's specifications.

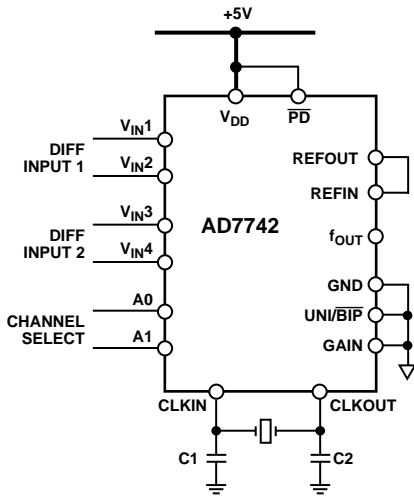

Figure 9. Basic Connection Diagram

### A/D Conversion Techniques Using the AD7741/AD7742

When used as an ADC, VFCs provide certain advantages including accuracy, linearity and being inherently monotonic. The AD7741/AD7742 has a true integrating input which smooths out noise peaks.

The most popular method of using a VFC in an A/D system is to count the output pulses of  $f_{OUT}$  for a fixed gate interval (see Figure 10). This fixed gate interval should be generated by dividing down the clock input frequency. This ensures that any errors due to clock jitter or clock frequency drift are eliminated. The ratio of the  $f_{OUT}$  to the clock frequency is what is important here, not the absolute value of  $f_{OUT}$ . The frequency division can be done by a binary counter where  $f_{CLKIN}$  is the CLK input.

Figure 11 shows the waveforms of  $f_{CLKIN}$ ,  $f_{OUT}$  and the Gate signal. A counter counts the rising edges of  $f_{OUT}$  while the Gate signal is high. Since the gate interval is not synchronized with  $f_{OUT}$ , there is a possibility of a counting inaccuracy. Depending on  $f_{OUT}$ , an error of one count may occur.

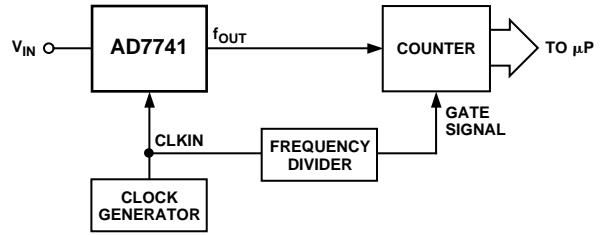

Figure 10. A/D Conversion Using the AD7741 VFC

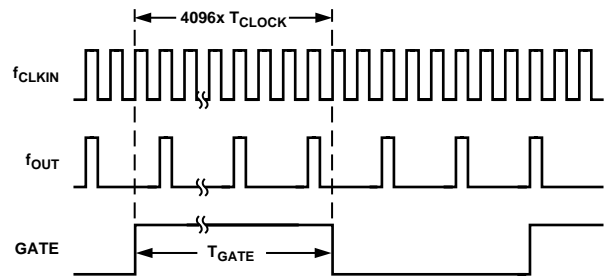

Figure 11. Waveforms in an A/D Converter Using a VFC

The clock frequency and the gate time determine the resolution of such an ADC. If 12-bit resolution is required and  $f_{CLKIN}$  is 5 MHz (therefore,  $f_{OUT}$  max is 2.25 MHz), the minimum gate time required is calculated as follows:

N counts at Full Scale (2.25 MHz) will take

$$(N/2.25 \times 10^6) \text{ seconds} = \text{minimum gate time.}$$

N is the total number of codes for a given resolution; 4096 for 12 bits

$$\text{minimum gate time} = (4096/2.25 \times 10^6) \text{ sec} = 1.820 \text{ ms.}$$

Since  $T_{GATE} \times f_{OUT} \text{ max} = \text{number of counts at full scale}$ , a faster conversion with the same resolution can be performed with a higher  $f_{OUT} \text{ max}$ . This high  $f_{OUT} \text{ max}$  (3 MHz) is a main feature of the AD7741/AD7742.

If the output frequency is measured by counting pulses gated to a signal which is derived from the clock, the clock stability is unimportant and the device simply performs as a voltage-controlled frequency divider, producing a high resolution ADC. The inherent monotonicity of the transfer function and wide range of input clock frequencies allows the conversion time and resolution to be optimized for specific applications.

There is another parameter is taken into account when choosing the length of the gate interval. Because the integration period of the system is equal to the gate interval, any interfering signal can be rejected by counting for an integer number of periods of the interfering signal. For example, a gate interval of 100 ms will give normal-mode rejection of 50 Hz and 60 Hz signals.

### Isolation Applications

In addition to analog-to-digital conversion, the AD7741/AD7742 can be used in isolated analog signal transmission applications. Due to noise, safety requirements or distance, it may be necessary to isolate the AD7741/AD7742 from any controlling circuitry. This can easily be achieved by using opto-isolators, which will provide isolation in excess of 3 kV.

Opto-electronic coupling is a popular method of isolated signal coupling. In this type of device, the signal is coupled from an input LED to an output photo-transistor, with light as the connecting medium. This technique allows dc to be transmitted, is extremely useful in overcoming ground loops between equipment, and is applicable over a wide range of speeds and power.

The analog voltage to be transmitted is converted to a pulse train using the VFC. An opto-isolator circuit is used to couple this pulse train across an isolation barrier using light as the connecting medium. The input LED of the isolator is driven from the output of the AD7741/AD7742. At the receiver side, the output transistor is operated in the photo-transistor mode. The pulse train can be reconverted to an analog voltage using a frequency-to-voltage converter; alternatively, the pulse train can be fed into a counter to generate a digital signal.

The analog and digital sections of the AD7741/AD7742 have been designed to allow operation from a single-ended power source, simplifying its use with isolated power supplies.

Figure 12 shows a general purpose VFC circuit using a low cost opto-isolator. A +5 V power supply is assumed for both the isolated (+5 V isolated) and local (+5 V local) supplies.

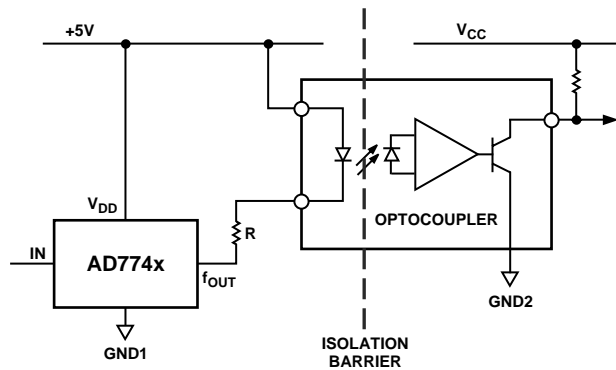

Figure 12. Opto-Isolated Application

### Power Supply Bypassing and Grounding

In any circuit where accuracy is important, careful consideration of the power supply and ground return layout helps to ensure the rated performance. The printed circuit board housing the AD7741/AD7742 should be designed so the analog and digital sections are separated and confined to certain areas of the board.

To minimize capacitive coupling between them, digital and analog ground planes should only be joined in one place, close to the DUT and should not overlap.

Avoid running digital lines under the device as these will couple noise onto the die. The analog ground plane should be allowed to run under the AD7742 to avoid noise coupling. The power supply lines to the AD7742 should use as large a trace as possible to provide low impedance paths and reduce the effects of glitches on the power supply line. Fast switching signals like clocks should be shielded with digital ground to avoid radiating noise to other parts of the board and clock signals should never be run near analog inputs. Avoid crossover of digital and analog signals. Traces on opposite sides of the board should run at right angles to each other. This reduces the effect of feedthrough through the board. A microstrip technique is by far the best but is not always possible with a double-sided board. In this technique, the component side of the board is dedicated to the ground plane while the signal traces are placed on the solder side.

Good decoupling is also important. All analog supplies should be decoupled to GND with surface mount capacitors, 10  $\mu\text{F}$  in parallel with 0.1  $\mu\text{F}$  located as close to the package as possible, ideally right up against the device. The lead lengths on the bypass capacitor should be as short as possible. It is essential that these capacitors be placed physically close to the AD7741/AD7742 to minimize the inductance of the PCB trace between the capacitor and the supply pin. The 10  $\mu\text{F}$  are the tantalum bead type and are located in the vicinity of the VFC to reduce low-frequency ripple. The 0.1  $\mu\text{F}$  capacitors should have low Effective Series Resistance (ESR) and Effective Series Inductance (ESI), such as the common ceramic types, which provide a low impedance path to ground at high frequencies to handle transient currents due to internal logic switching. Additionally, it is beneficial to have large capacitors (> 47  $\mu\text{F}$ ) located at the point where the power connects to the PCB.

## OUTLINE DIMENSIONS

Dimensions shown in inches and (mm).

### 8-Lead Plastic DIP (N-8)

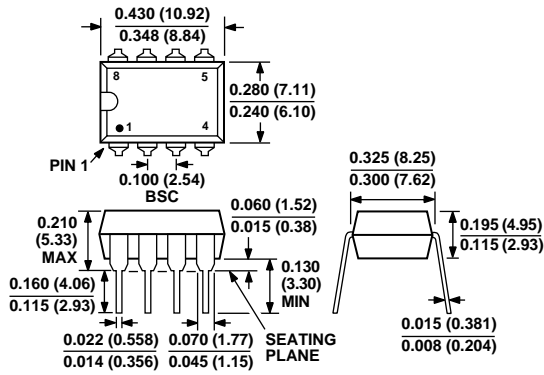

### 8-Lead SO (R-8)

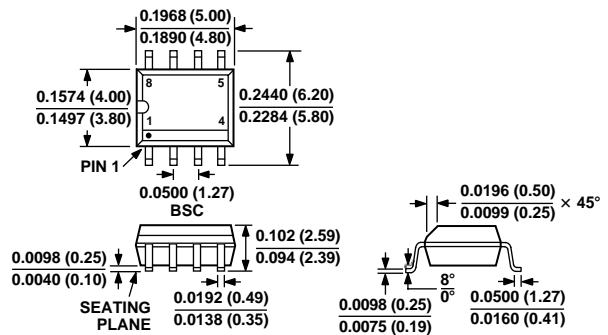

### 16-Lead Plastic DIP (N-16)

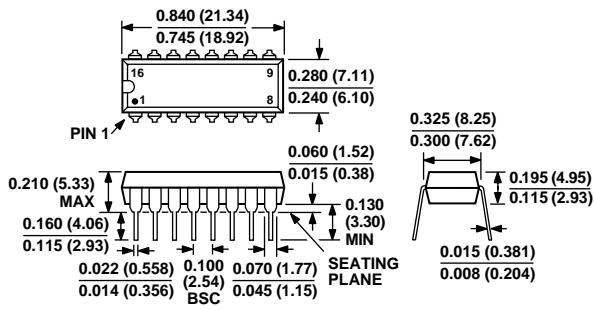

### 16-Lead Narrow Body SO (R-16A)

