

**EVAL-AD8170EB/EVAL-AD8174EB****BOARD DESCRIPTION**

The AD8170 and AD8174 evaluation boards have been carefully laid out and tested to demonstrate the specified high speed performance of the devices. Figures 1 and 5 show the schematics of the AD8170 and AD8174 evaluation boards respectively. For ordering information, please refer to the Ordering Guide.

Figure 2 shows the silkscreen of the component side of the solder side of the AD8170 evaluation board. Figures 3 and 4 show the layout of the component side and solder side respectively. The silkscreens and layout of the AD8174 evaluation board are shown in Figures 6–9.

Both evaluation boards ship with 75  $\Omega$  termination resistors on their analog inputs and analog outputs. To use the evaluation board in nonvideo applications where 50  $\Omega$  termination is more popular, these resistors can be replaced with 50  $\Omega$  values. The digital control pins are terminated with 50  $\Omega$  resistors to allow easy connection to laboratory equipment.

The gain of the output current feedback op amp on both boards has been set to +2. For other gains the two gain resistors can be easily replaced. Refer to Table III of the AD8170/AD8174 data sheet for appropriate values at gains other than +2.

For connection to external instruments, side-launched SMA type connectors are provided. Space is also provided on the board for the installation of SMB or SMC type connectors.

**ORDERING GUIDE**

Model	Package Description
AD8170-EB	Evaluation Board
AD8174-EB	Evaluation Board

**CAUTION**

ESD (electrostatic discharge) sensitive device. Electrostatic charges as high as 4000 V readily accumulate on the human body and test equipment and can discharge without detection. Although the EVAL-AD8170EB/EVAL-AD8174EB features proprietary ESD protection circuitry, permanent damage may occur on devices subjected to high energy electrostatic discharges. Therefore, proper ESD precautions are recommended to avoid performance degradation or loss of functionality.



REV. 0

Information furnished by Analog Devices is believed to be accurate and reliable. However, no responsibility is assumed by Analog Devices for its use, nor for any infringements of patents or other rights of third parties that may result from its use. No license is granted by implication or otherwise under any patent or patent rights of Analog Devices. Trademarks and registered trademarks are the property of their respective companies.

One Technology Way, P.O. Box 9106, Norwood, MA 02062-9106, U.S.A.  
Tel: 781/329-4700 [www.analog.com](http://www.analog.com)  
Fax: 781/326-8703 © 2002 Analog Devices, Inc. All rights reserved.

# EVAL-AD8170EB/EVAL-AD8174EB

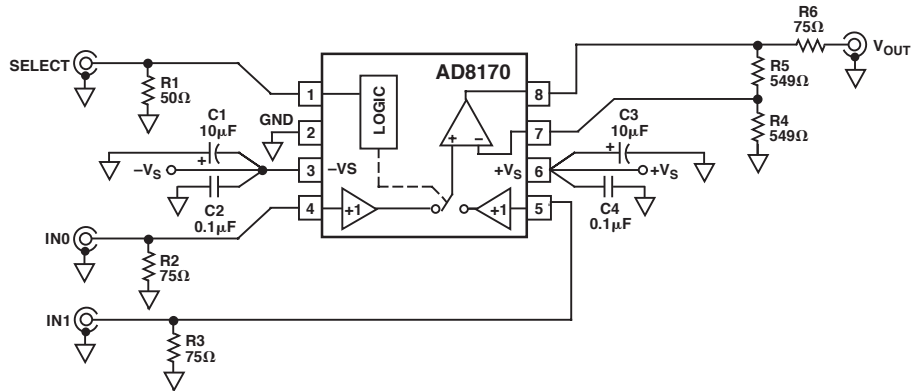

Figure 1. AD8170 Evaluation Board

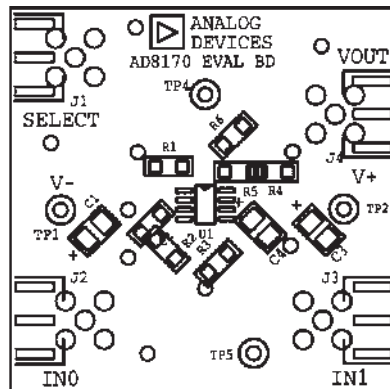

Figure 2. EVAL-AD8170EB Component Side Silkscreen

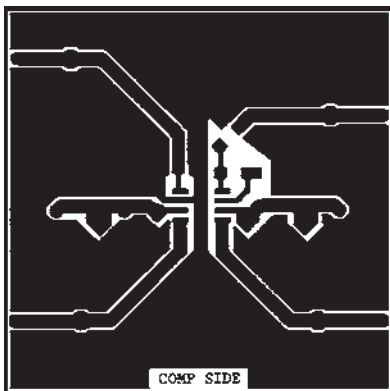

Figure 3. EVAL-AD8170EB Board Layout (Component Side)

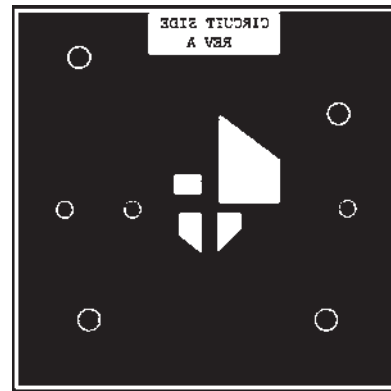

Figure 4. EVAL-AD8170EB Board Layout (Solder Side)

# EVAL-AD8170EB/EVAL-AD8174EB

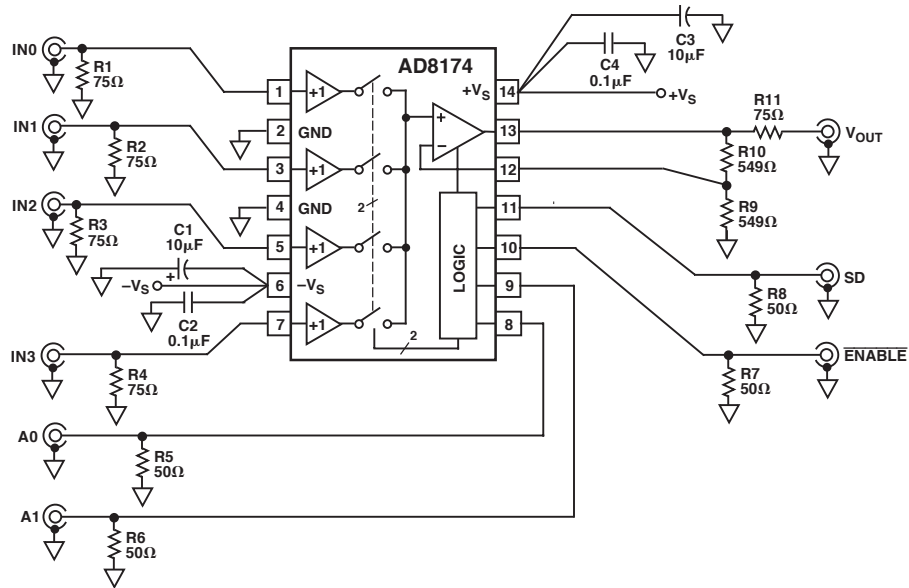

Figure 5. AD8174 Evaluation Board

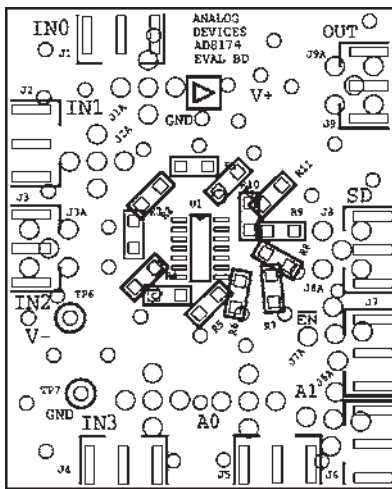

Figure 6. EVAL-AD8174EB Component Side Silkscreen

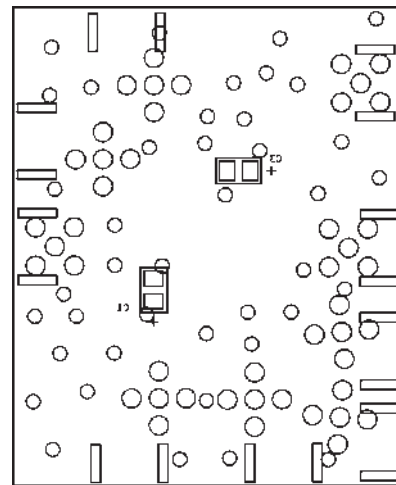

Figure 8. EVAL-AD8174EB Solder Side Silkscreen

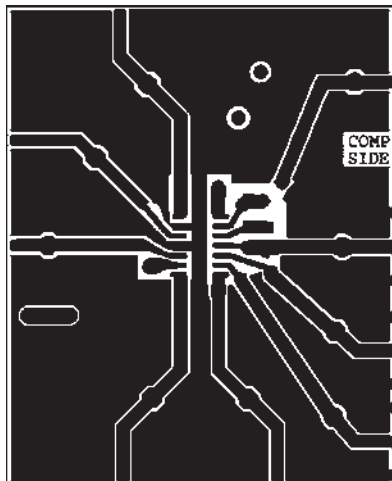

Figure 7. EVAL-AD8174EB Board Layout (Component Side)

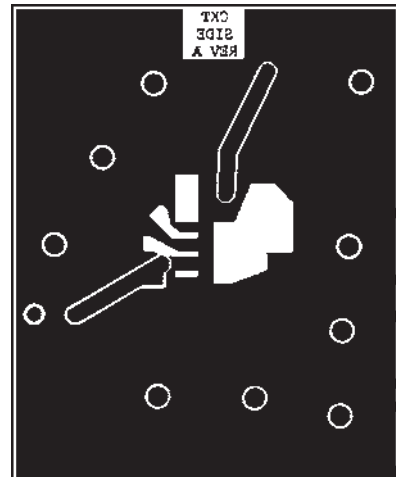

Figure 9. EVAL-AD8174EB Board Layout (Solder Side)

