

## Single-Point Optical Through-Beam Sensor

## E3C-T1

Compact, Narrow-View Sensor Is Ideal for Sensing Wafers — Using OMRON's Unique "Pin-point" LED

- 0.1-ms ultra-high-speed response
- Safer and more cost-effective than comparable laser products
- Use the E3C-T1 amplifier's turbo feature combined with the sensor's "pin-point" red LED, to achieve a visible 1.2-mm-diameter spot at a sensing distance of 12 cm
- The flexible robotics cable makes E3C-T1 ideal for applications requiring remote sensor placement on moving parts

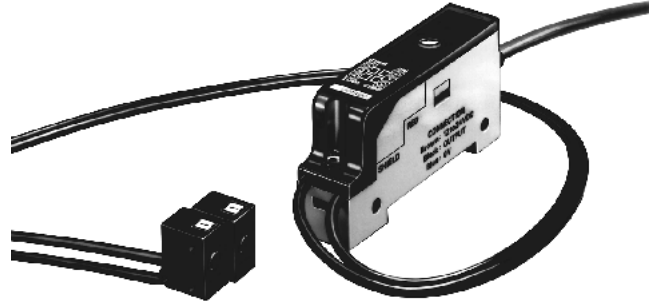

## Ordering Information

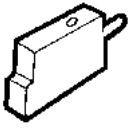
Description	Appearance	Sensing distance	Output	Part number
Through-beam sensor and amplifier	<div style="display: flex; justify-content: space-around;"> <div style="text-align: center;"> <p>Sensing head</p>  </div> <div style="text-align: center;"> <p>Amplifier</p>  </div> </div>	50 cm	NPN	<b>E3C-T1</b> (Sensor and Amplifier)

## Specifications

### RATINGS/CHARACTERISTICS

Part number	E3C-T1
Method of detection	Through-beam
Light source for emitter	Red LED (670 nm)
Sensing distance	50 cm (1.64 ft)
Direction angle	1° max.
Minimum sensing object	0.5-mm dia. (opaque object)
Power supply voltage	12 to 24 VDC ±10%, ripple (p-p): 1 V max.
Current consumption	50 mA max. (70 mA max. with turbo switch turned ON)
Response time	0.1 ms max. for both operating and release
Indicators	Light incident (red LED), stability (green LED)
Control output	Load current: 100 mA max., NPN open collector with a maximum residual voltage of 1 V
Operation mode	Light-ON and Dark-ON switch selectable
Connection method	Sensor: Preleaded (standard cable length: 1 m) Amplifier: Terminal block, preleaded (standard cable length: 2 m)

(This table continues on the next page.)

Specifications Table - continued from previous page

Part number		E3C-T1
Ambient illumination		Incandescent lamp: 3,000 lx max. Sunlight: 10,000 lx max.
Ambient temperature	Operating	-10°C to 40°C (14°F to 104°F) with no icing or condensation
Relative humidity		35% to 85%
Vibration resistance		10 to 55 Hz, 1.5-mm double amplitude for 2 hrs each in X, Y, and Z axes
Shock resistance		500 m/s <sup>2</sup> (approx. 50G) for Sensing head: and 300 m/s <sup>2</sup> (approx. 30G) for Amplifier for 3 times each in X, Y, and Z axes
Enclosure ratings		IEC IP64 for Sensing head: and IP20 for Amplifier
Material	Case	ABS
	Cover	Polycarbonate
	Lens	Acrylic
Weight		Sensing head: Approx. 50 g with 1-m cable Amplifier: Approx. 80 g with 2-m cable

## Operation

### ■ OUTPUT CIRCUIT

Operation mode selector	LIGHT ON	DARK ON
Output transistor	ON when light is received	ON when light is interrupted
Output circuit		
Timing chart	<p>Light received Light not received</p> <p>Light indicator (red) ON OFF</p> <p>Output transistor ON OFF</p> <p>Load (relay) Operate Release</p> <p>(Between brown and black)</p>	<p>Light received Light not received</p> <p>Light indicator (red) ON OFF</p> <p>Output transistor ON OFF</p> <p>Load (relay) Operate Release</p> <p>(Between brown and black)</p>

# Engineering Data

## ■ PARALLEL OPERATING RANGE (TYPICAL)

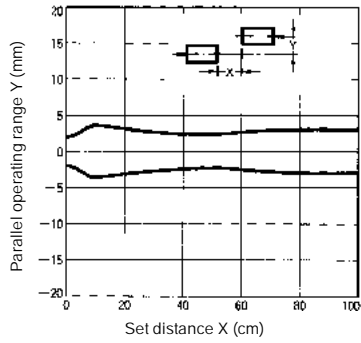

## ■ EXCESS GAIN RATIO (TYPICAL)

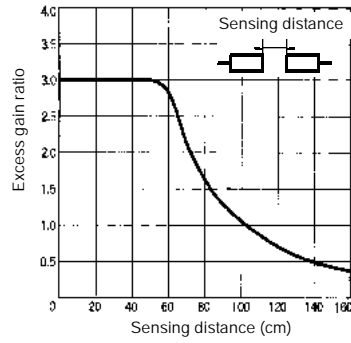

# Dimensions

Unit: mm (inch)

## ■ SENSING HEAD

E3C-T1L (Emitter)  
E3C-T1D (Receiver)

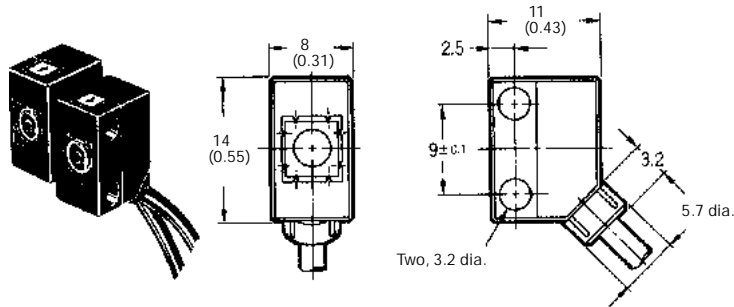

Cable: Robotics cable  
2.4-mm dia. (60/0.08 dia.)  
Standard length: 1 m  
Weight: Approx. 50 g

■ AMPLIFIER

E3C-T1A

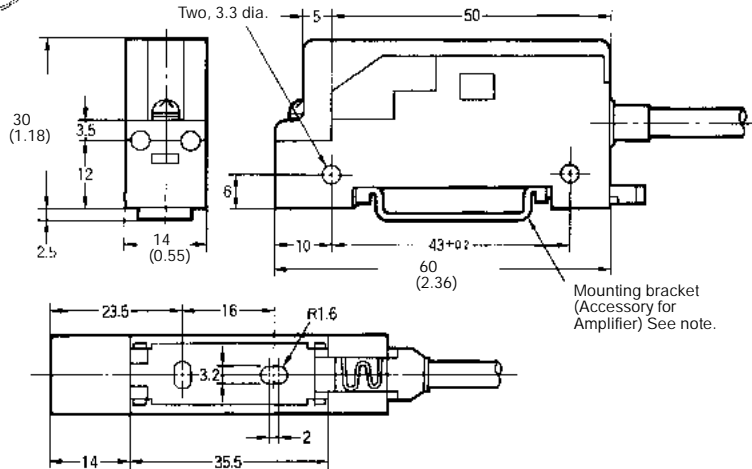
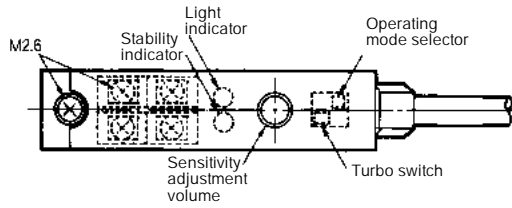
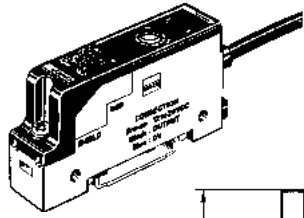

Cable: Polyvinyl chloride-covered cable  
4-mm dia. (18/0.12 dia.), 3 cores  
Standard length: 2 m

Weight: Approx. 80 g

Note: The mounting bracket is not required for DIN-rail mounting.

## Installation

### ■ SENSOR AND AMPLIFIER CONNECTIONS

- Be sure to connect the sensing heads to the dedicated E3C-T1A Amplifier.
- To avoid damage to the Sensor, DO NOT connect the E3C-T1L Emitter or E3C-T1D Receiver to the E3C-JC4, E3C-JC4P, or the E3C-JB4P.
- Be sure that the length of the bare core of each cable is 2 cm maximum.
- Securely tighten all terminal screws after wiring.

### ■ OPTICAL AXIS ADJUSTMENT

The E3C-T1 is used for the detection of minute objects. Because the beam spot is very small, it may take some time to adjust the optical axis.

For mounting, move the emitter and receiver up, down, left, and right to position them in the center of the area that will turn the light indicator on. Then, mount the emitter and receiver securely.

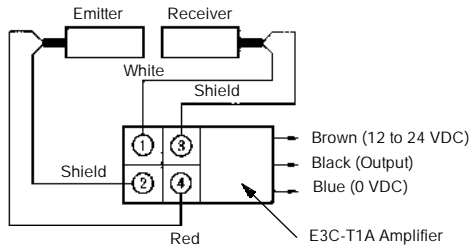

## Precautions

### ■ ENVIRONMENT

To avoid damage to the E3C-T1:

- Do not use the E3C-T1 in places with explosive or flammable gas.
- Do not impose any voltage exceeding the rated voltage on the E3C-T1.
- Do not short-circuit the load connected to the E3C-T1.
- DO NOT connect the E3C-T1L Emitter or E3C-T1D Receiver to the E3C-JC4, E3C-JC4P, or the E3C-JB4P.

**NOTE: DIMENSIONS SHOWN ARE IN MILLIMETERS. To convert millimeters to inches divide by 25.4.**

**OMRON**<sup>®</sup>  
**OMRON ELECTRONICS LLC**  
One East Commerce Drive  
Schaumburg, IL 60173  
**1-800-55-OMRON**

**OMRON ON-LINE**  
Global - <http://www.omron.com>  
USA - <http://www.omron.com/oei>  
Canada - <http://www.omron.com/oci>

**OMRON CANADA, INC.**  
885 Milner Avenue  
Scarborough, Ontario M1B 5V8  
**416-286-6465**

**NOTE: DIMENSIONS SHOWN ARE IN MILLIMETERS. To convert millimeters to inches divide by 25.4.**

**OMRON**<sup>®</sup>

**OMRON ELECTRONICS LLC**

One East Commerce Drive  
Schaumburg, IL 60173

**1-800-55-OMRON**

**OMRON ON-LINE**

Global - <http://www.omron.com>  
USA - <http://www.omron.com/oei>  
Canada - <http://www.omron.com/oci>

**OMRON CANADA, INC.**

885 Milner Avenue  
Scarborough, Ontario M1B 5V8

**416-286-6465**