

AHB 127 x 127 x 38 MM SERIES

DIMENSIONS DRAWING

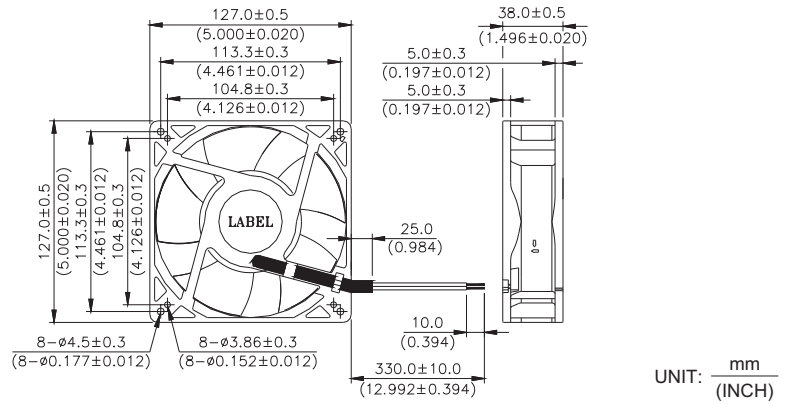

- * Bearing Type
Ball Bearings
- * Material
Impeller : Plastic (UL 94V-0)
Frame : Die-cast Aluminum
- * Lead Wires :
UL 1007 AWG #24 OR Equivalent
Red Wire Positive (+)
Black Wire Negative (-)
- * Weight : 490g (17.28 oz)

P & Q CURVE (AT RATED VOLTAGE)

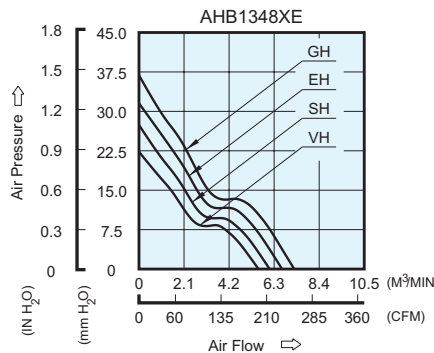

MOUNTING PANEL CUTOUT

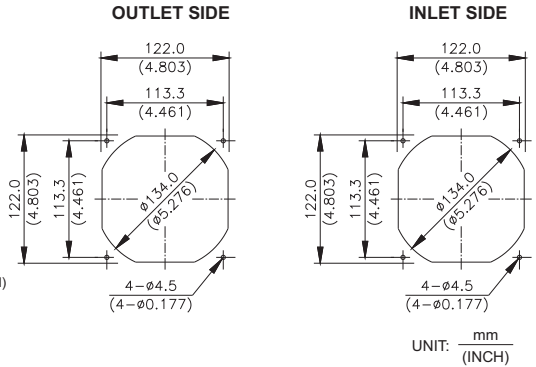

MODEL		Rated Voltage	Operating Voltage Range	Input Current	Input Power	Speed	Maximum Air Flow		Maximum Air Pressure		Noise
PART NO.	FUNCTION	VDC	VDC	Amp	Watt	R.P.M.	m ³ /min	CFM	mmH ₂ O	IN H ₂ O	dB-A
AHB1348VHE	-R00 / -F00	48	32.0 to 80.0	0.41	19.68	4300	5.573	196.82	22.39	0.881	60.5
AHB1348SHE	-R00 / -F00	48	32.0 to 80.0	0.49	23.52	4700	6.091	215.12	26.79	1.055	63.0
AHB1348EHE	-R00 / -F00	48	32.0 to 80.0	0.61	29.28	5100	6.660	235.20	31.41	1.237	65.0
AHB1348GHE	-R00 / -F00	48	32.0 to 80.0	0.75	36.00	5500	7.243	255.77	36.77	1.448	67.0

- * Function type is optional.
- * The max. air flow and the speed are measured in free air ; max. air pressure is measured at zero air flow.
- * Noise is measured in anechoic chamber in free air, one meter from intake side.
- * All readings are typical values at rated voltage.
- * Specifications are subject to change without notice.