

Features

- Available sharp click feel with a positive tactile feedback
- Ultra-miniature and lightweight structure suitable for high density mounting
- Economical with high reliability
- RoHS compliant*



The SDT Series is currently available, although not recommended for new designs.

- Insert molding in the contact with special treatment prevents flux buildup during soldering and permits autodipping

SDT Series Tact Switch

Electrical Characteristics

Electrical Life

.....500,000 cycles min. for 260 g
 1,000,000 cycles min. for 100 g, 160 g
 RatingDC 12 V 50 mA
 Contact Resistance100 milliohms max.
 Insulation Resistance
100 megohms, DC 500 V min.
 Dielectric Strength250 V AC for 1 minute
 Contact Arrangement1 pole 1 position

Environmental Characteristics

Operation Force260 g \pm 50 g,
 160 g \pm 50 g, 100 g \pm 50 g
 Stop StrengthPlace the switch such
 that vertical, a static load of 3 kg shall
 be applied in the direction of actuator
 operation for a period of 15 sec.
 Stroke
 6mm type0.25 + 0.2/- 0.1 mm
 12mm type0.35 \pm 0.1 mm
 Temperature Range-20 °C to +70 °C
 Vibration TestMil-STD-202F,
 Method 201A
 Frequency10-55-10 Hz/1 minute
 DirectionsX,Y,Z, three mutually
 perpendicular directions
 Time2 hours each direction.
 High reliability
 Shock TestMIL-STD-202F,
 Method 213B, Condition A
 Gravity50 G (peak value), 11 msec
 Direction & Times6 sides and
 3 times in each direction.
 High reliability

Physical Characteristics

Cover MaterialsSteel
 Base MaterialsUL94V-0 PBT plus glass
 fiber reinforced
 Cover/Base ColorBlack
 Actuator MaterialsDulacron POM
 plus glass fiber reinforced
 Actuator ColorBlack, brown, red
 Contact Disc MaterialsPhosphor bronze
 with silver cladding
 Terminal Materials
Brass with silver cladding
 Hand Soldering Process
350 °C \pm 10 °C / 5 seconds max.
 Wave Soldering Process
Preheat 100 °C / 60 seconds
 260 °C \pm 5 °C / 5 seconds
 Packaging1,000 pieces per bag

Product Dimensions

SDTX-610/620/630/650/660

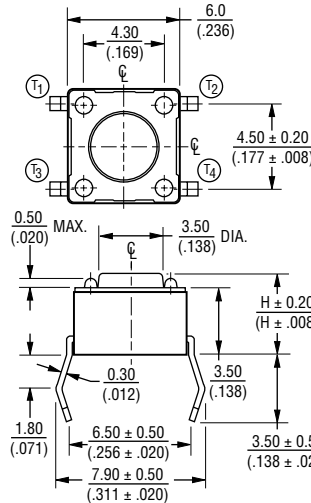

SDTG-610/620/630/650/660

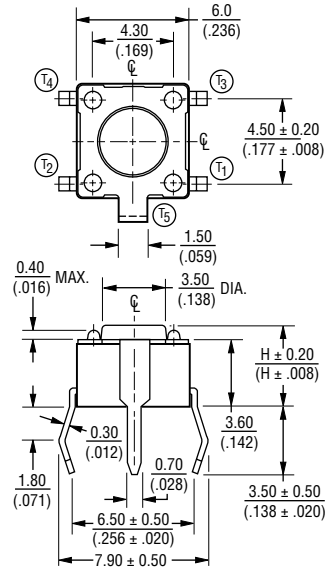

SDTX-644/648

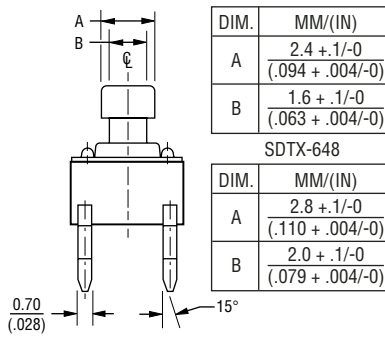

SDTG-644/648

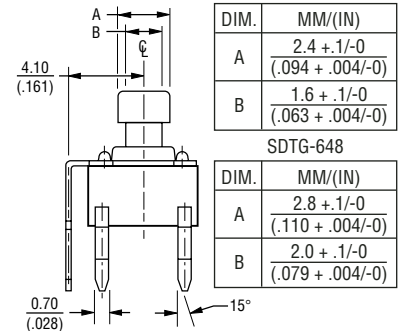

RECOMMENDED PCB LAYOUT

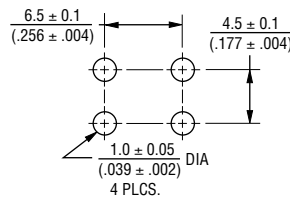

CIRCUIT DIAGRAM

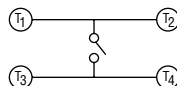

DIMENSIONS: MM (IN)

CIRCUIT DIAGRAM

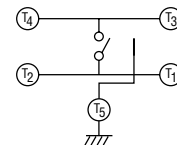

RECOMMENDED PCB LAYOUT

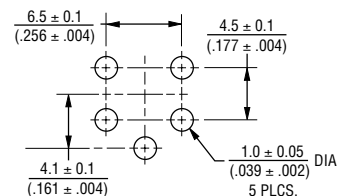

*RoHS Directive 2002/95/EC Jan 27 2003 including Annex. Specifications are subject to change without notice. Customers should verify actual device performance in their specific applications.

SDT Series Tact Switch

BOURNS®

Product Dimensions

SDTA-610/620/630/650/660

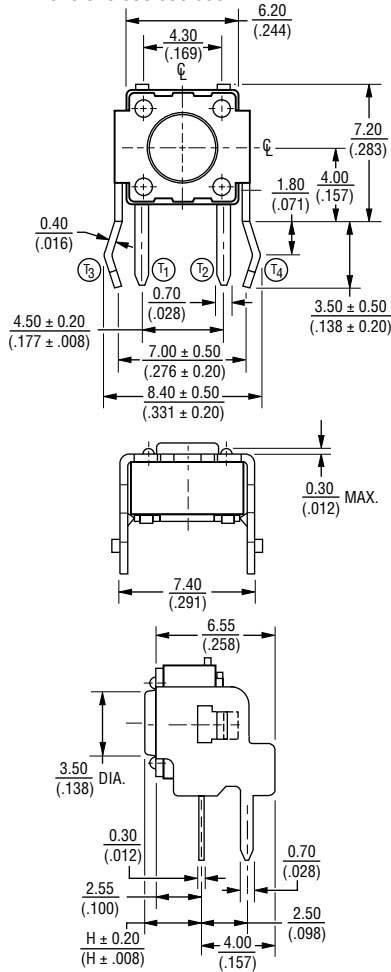

RECOMMENDED PCB LAYOUT

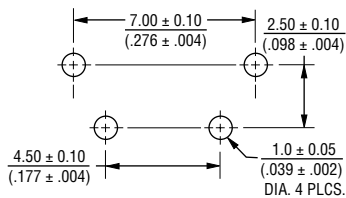

CIRCUIT DIAGRAM

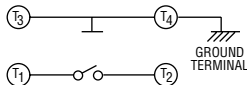

SDTA-644/648

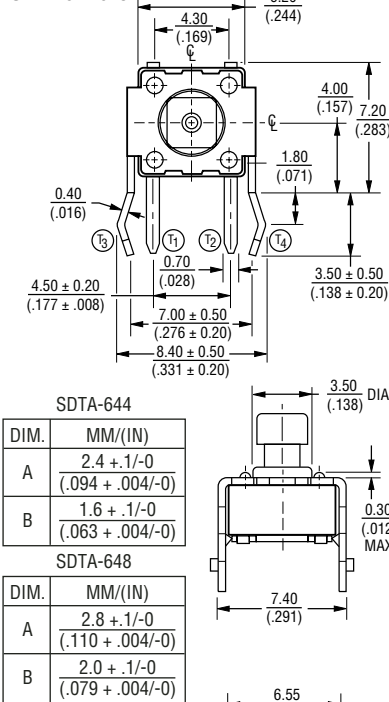

SDTA-644

DIM.	MM/(IN)
A	2.4 +.1/-0 (.094 + .004/-0)
B	1.6 +.1/-0 (.063 + .004/-0)

SDTA-648

DIM.	MM/(IN)
A	2.8 +.1/-0 (.110 + .004/-0)
B	2.0 +.1/-0 (.079 + .004/-0)

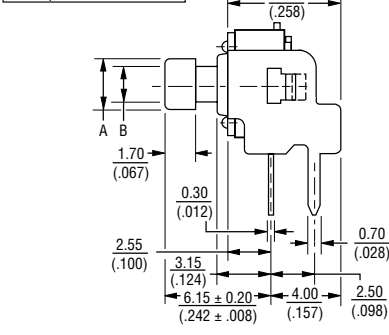

RECOMMENDED PCB LAYOUT

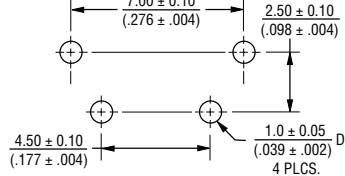

CIRCUIT DIAGRAM

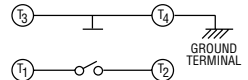

SDTX-210

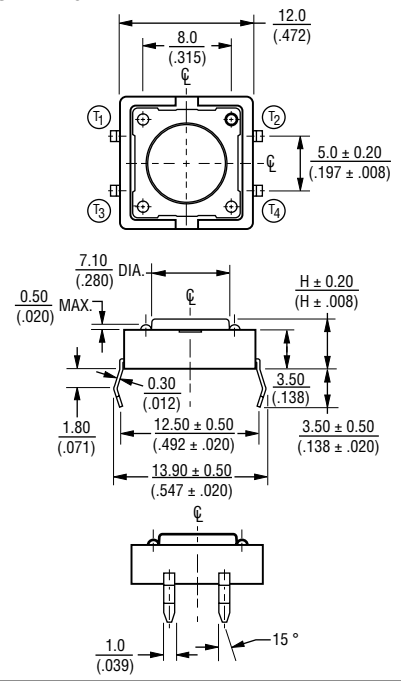

RECOMMENDED PCB LAYOUT

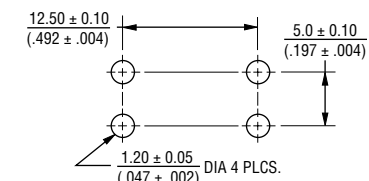

CIRCUIT DIAGRAM

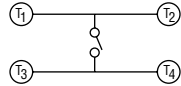

Specifications are subject to change without notice. Customers should verify actual device performance in their specific applications.

SDT Series Tact Switch

BOURNS®

Product Dimensions

SDTX-244

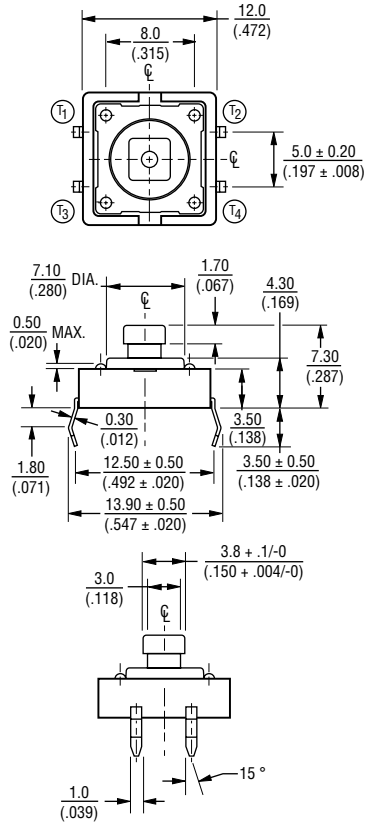

RECOMMENDED PCB LAYOUT

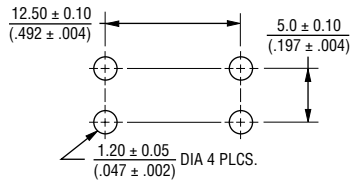

CIRCUIT DIAGRAM

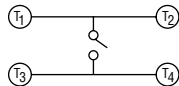

Packaging Specifications

SDTX-610/620/630/644/648/650 Ammo Pack

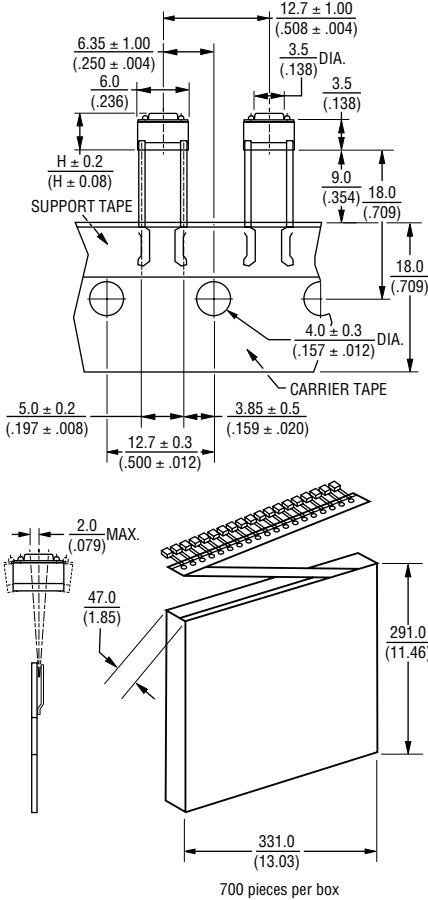

RECOMMENDED PCB LAYOUT

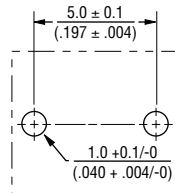

CIRCUIT DIAGRAM

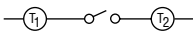

How to Order

SDT G - 6 10 - K AP

- Model _____
- Product Series _____
- X = Standard
 - G = Ground Terminal
 - A = Right Angle Type
- Body Size _____
- 6 = 6 mm
 - 2 = 12 mm *
- Distance From First Pin to Top of Head (Right Angle Type) _____
- 10 = 3.15 mm
 - 20 = 3.85 mm
 - 30 = 5.85 mm
 - 44 = 6.15 mm (square head)
 - 48 = 6.15 mm (square head)
 - 50 = 8.35 mm
 - 60 = 11.85 mm
- Height (Standard Type) _____
- 10 = 4.3 mm
 - 20 = 5.0 mm
 - 30 = 7.0 mm
 - 44 = 7.3 mm x 2.4 mm (square head)
 - 48 = 7.3 mm x 2.8 mm (square head)
 - 50 = 9.5 mm
 - 60 = 13 mm
- Actuating Force _____
- K = 100 g (black head - 6 mm only)
 - N = 160 g (brown head)
 - R = 260 g (red head)
 - S = 320 g (salmon head - 6 mm only)
 - Y = 520 g (yellow head - 6 mm only)
- Packaging Option _____ (SDTX only)
- AP = Ammo Pack
- * Options available:
- SDTX-210
 - SDTX-244