



128MB to 16GB  
IDE Flash Drive



www.stec-inc.com

## SLFLD25-xxx(M/G)M1U(I)

Solid-State IDE Flash Drive  
(No Moving Parts)

Capacity: 128MB - 16GB

ATA-5 Compatible

ATA Transfer modes: PIO 0-6,  
MWDMA 0-4

Supports True IDE Mode

Form Factors:

- 2.5-inch ruggedized enclosure with 44-pin IDE connector

Endurance Guarantee of 2,000,000  
Write/Erase Cycles

Master or Slave Select by Jumper

5V or 3.3V Power Supply

Commercial and Industrial  
Operating Temperature Range

5-Byte Detection, 4-Byte Correction  
ECC Engine

10 Year Data Retention

RoHS-6 Compliant

### General Description

STEC's IDE Flash Drive has no moving parts and is available in capacities from 128MB to 16GB. The IDE Flash Drive has a 2.5-inch ruggedized enclosure and a 44-pin connector with a standard IDE interface, providing designers with a true plug-n-play storage device and allowing for short design cycles and fast time to market.

STEC's proprietary state-of-the-art flash memory controller is incorporated in the IDE Flash Drive, providing high data reliability and endurance. The built-in ECC engine can detect up to 5-byte errors and correct up to 4-byte errors, while sophisticated wear leveling algorithms guarantee 2,000,000 Write/Erase Cycles.

STEC's IDE Flash Drive is the product of choice in applications requiring high reliability and high tolerance to shock, vibration, humidity, altitude, and temperature. Because there are no moving parts, the STEC IDE Flash Drive is a reliable alternative to mechanical hard disk drives for mission critical applications.

### Ordering Information

#### IDE Flash Drive

Part Number	Form Factor	Capacity
SLFLD25-128MM1U(I)	2.5-inch/44-pin	128 Mbytes
SLFLD25-256MM1U(I)	2.5-inch/44-pin	256 Mbytes
SLFLD25-512MM1U(I)	2.5-inch/44-pin	512 Mbytes
SLFLD25-1GM1U(I)	2.5-inch/44-pin	1 GByte
SLFLD25-2GM1U(I)	2.5-inch/44-pin	2 GBytes
SLFLD25-4GM1U(I)	2.5-inch/44-pin	4 GByte
SLFLD25-8GM1U(I)	2.5-inch/44-pin	8 GByte
SLFLD25-16GM1U(I)	2.5-inch/44-pin	16 GByte

#### Legend:

- (I) = Industrial temperature range (-40°C to +85 °C).
- Part numbers without (I) = Commercial temperature range (0°C to 70°C).
- (M/G) indicates if preceding capacity (xxx) is in Megabytes (M) or Gigabytes (G).
- U = RoHS-6 compliant lead-free.

## Table of Contents

<b>1.0 Product Specifications</b>	<b>3</b>
1.1 Labeling	3
1.2 Package Dimensions and Pin Locations	4
1.3 Master/Slave Jumper Settings	5
1.4 Pin Assignment	6
1.5 Signal Description	7
1.6 Performance	8
1.7 CHS Parameters	8
<b>2.0 Environmental Specifications</b>	<b>9</b>
2.1 Recommended Operating Conditions	9
2.2 Reliability	9
2.3 Shock, Vibration, and Humidity	9
<b>3.0 Electrical Specifications</b>	<b>10</b>
3.1 Absolute Maximum Ratings	10
3.2 DC Characteristics	10
3.3 AC Characteristics	11
3.3.1 True IDE Mode Register Access	11
3.3.2 True IDE Mode PIO Access	12
3.3.3 True IDE Mode Multiword DMA	14
<b>4.0 Identify Drive Parameter Information</b>	<b>15</b>
<b>5.0 Registers</b>	<b>16</b>
<b>6.0 Supported ATA Commands</b>	<b>17</b>
<b>7.0 Revision History</b>	<b>20</b>

## 1.0 Product Specifications

### 1.1 Labeling

STEC flash drives can be manufactured with standard labeling, or customer-specific, custom labeling.

Standard labeling is shown in Figure 1.

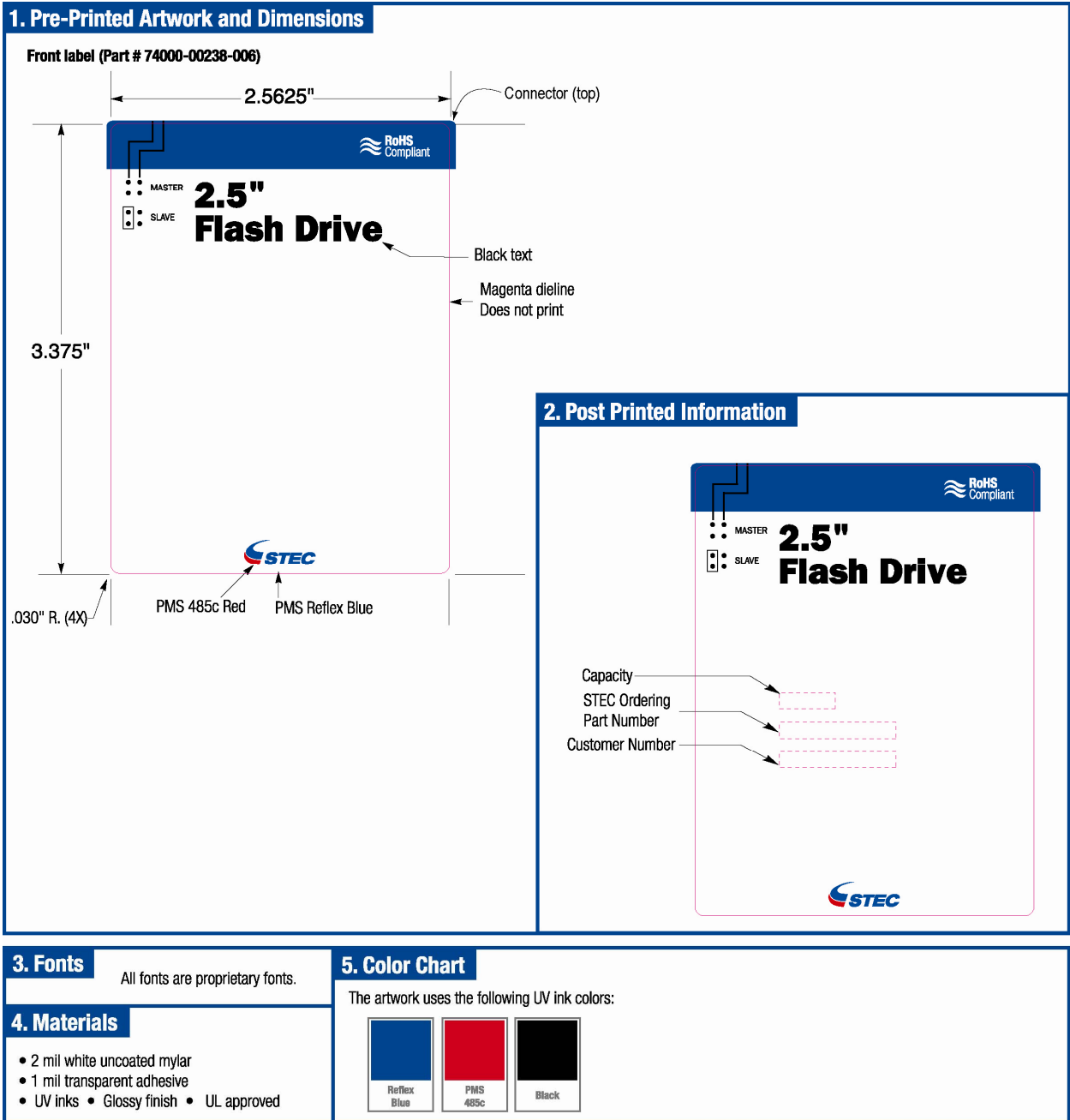

Figure 1: Standard Labeling

## 1.2 Package Dimensions and Pin Locations

Figure 2 and Table 1 show the mechanical dimensions of the 2.5-inch drive with ruggedized enclosure.

Table 1: Mechanical dimensions of the 2.5-inch drive

Parameter	Value
Length	100.20 ± 0.127 mm (3.945 ± 0.005 in)
Width	69.85 ± 0.127 mm (2.750 ± 0.005 in)
Height	9.5 mm (0.375 in) max

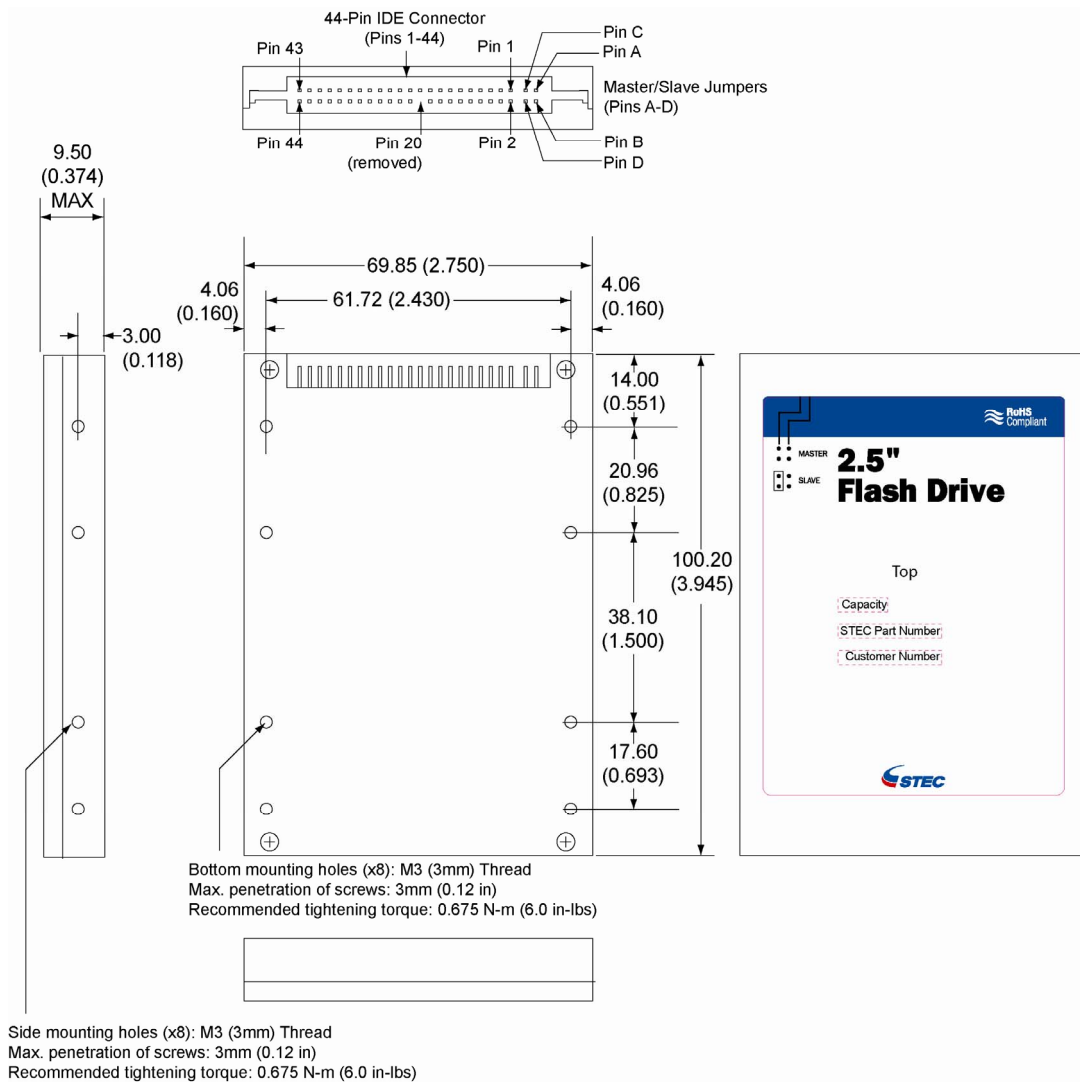
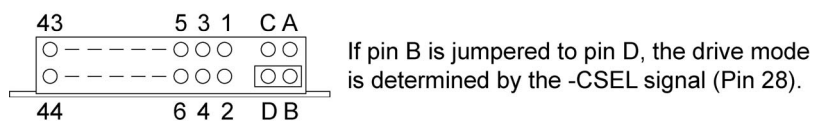
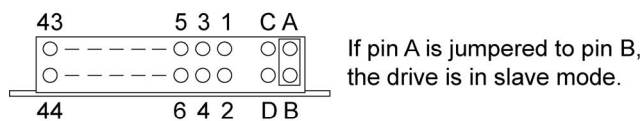
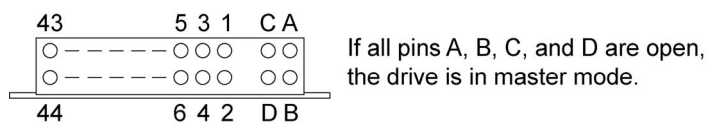

Figure 2: Mechanical dimensions of the 2.5-inch drive

### 1.3 Master/Slave Jumper Settings



NOTE: In multiple drive configuration, it may become necessary to establish master drive and slave drive. This can be done by booting the PC and using IDE HDD Auto Detection available in CMOS setup.

Figure 3: Master/Slave Jumper Settings

## 1.4 Pin Assignment

Table 2: IDE Flash Drive Pin Assignment

Pin Number	Signal Name	Pin Type	Pin Number	Signal Name	Pin Type
1	-RESET	I	23	-IOWR	I
2	GND	Ground	24	GND	Ground
3	D07	I/O	25	-IORD	I
4	D08	I/O	26	GND	Ground
5	D06	I/O	27	-IORDY	O
6	D09	I/O	28	-CSEL	I
7	D05	I/O	29	-DMACK	I
8	D10	I/O	30	GND	Ground
9	D04	I/O	31	INTRQ	O
10	D11	I/O	32	-IOIS16	O
11	D03	I/O	33	A1	I
12	D12	I/O	34	-PDIAG	I/O
13	D02	I/O	35	A0	I
14	D13	I/O	36	A2	I
15	D01	I/O	37	-CE1	I
16	D14	I/O	38	-CE2	I
17	D00	I/O	39	-DASP	I/O
18	D15	I/O	40	GND	Ground
19	GND	Ground	41	VCC	Power
20	Key	Key	42	VCC	Power
21	DMARQ	O	43	GND	Ground
22	GND	Ground	44	NC	No Connect

Legend: "-" = Low active

## 1.5 Signal Description

Table 3: IDE Flash Drive Signal Description

Signal Name	Dir	Pin	Description
-DASP	I/O	39	This input/output is the Disk Active/Slave Present signal in the Master/ Slave handshake protocol.
D15-D00	I/O	18, 16, 14, 12, 10, 8, 6, 4, 3, 5, 7, 9, 11, 13, 15, 17	All Task File operations occur in byte mode on the low order bus D00-D07 while all data transfers are 16 bit using D00-D15.
-IOWR	I	23	The I/O Write strobe pulse is used to clock I/O data on the module Data bus into the Module controller registers when the Module is configured to use the I/O interface. The clocking will occur on the negative to positive edge of the signal (trailing edge).
-IORD	I	25	This is an I/O Read strobe generated by the host. This signal gates I/O data onto the bus from the Module.
INTRQ	O	31	Signal is the active high Interrupt Request to the host.
A2-A0	I	35, 33, 36	A[2:0] are used to select the one of eight registers in the Task File.
-CE1, -CE2	I	37, 38	-CS1 is the chip select for the task file registers while -CS2 is used to select the Alternate Status Register and the Device Control Register.
-CSEL	I	28	This internally pulled up signal is used to configure the card as a Master or Slave. When the pin is grounded, the card is configured as a Master. When the pin is open, the card is configured as a Slave.
-IOIS16	O	32	Not used.
-PDIAG	I/O	34	This input/output is the Pass Diagnostic signal in the Master/Slave handshake protocol.
DMARQ	O	21	This signal is asserted by the device when it is ready to transfer data to/ from the host. Data direction is controlled by -IORD and -IOWR. This signal is used in a handshake manner with -DMACK.
-DMACK	I	29	This input signal is used by host in response to DMARQ to initiate DMA transfers.
-IORDY	O	27	Not used, and pulled up to VCC through a 4.7K ohm resistor.
-RESET	I	1	This input pin is the active low hardware reset from the host.
VCC	—	41, 42	Power.
GND	—	2, 19, 22, 24, 26, 30, 40, 43	Ground.
Key	—	20	This pin is keyed to ensure cable is connected with the proper orientation.
NC	—	44	No connect.

## 1.6 Performance

Table 4: IDE Flash Drive Read/Write Performance

Parameter	Value
Data transfer rate to/from host	16.7 MBytes/s (burst)
Sustained read	up to 10 MBytes/s
Sustained write	up to 7 MBytes/s

## 1.7 CHS Parameters

Table 5: CHS Parameters per capacity

Capacity	Cylinder (C)	Head (H)	Sectors/Track (S)
128MB	980	8	32
256MB	980	16	32
512MB	993	16	63
1GB	1,986	16	63
2GB	3,970	16	63
4GB	7,964	16	63
8GB	16,062	16	63
16GB	31,760	16	63



## 2.0 Environmental Specifications

### 2.1 Recommended Operating Conditions

Table 6: IDE Flash Drive Recommended Operating Conditions

Parameter	Symbol	Min	Typ	Max	Unit
Commercial Operating Temperature	Ta	0	25	70	°C
Industrial Operating Temperature	Ta	-40	-	85	°C
VCC voltage	VCC	4.75	5.0	5.25	V
		3.18	3.3	3.465	V

### 2.2 Reliability

Table 7: IDE Flash Drive Endurance & Data Reliability

Parameter	Value
Endurance	2,000,000 Write/Erase Cycles
Data reliability	1 in 10 <sup>14</sup> bits, read
Data retention	10 years

### 2.3 Shock, Vibration, and Humidity

Table 8: IDE Flash Drive Shock, Vibration & Humidity

Parameter	Value
Shock	1.5K G peak, 0.5ms pulse duration, five (5) pulses per each of six (6) directions (per JEDEC JESD22 standard, method B110)
Vibration	20 G peak, 20Hz-2000Hz, 4 cycles per direction (per JEDEC JESD22 standard, method B103)
Humidity	85°C 85% RH, 500 hrs

### 3.0 Electrical Specifications

#### 3.1 Absolute Maximum Ratings

Table 9: IDE Flash Drive Absolute Maximum Ratings

Parameter	Symbol	Value	Unit
Voltage	Vin, Vout	-0.5 to VCC +0.5	V
Storage temperature range	Tstg	-65 to +150	°C

#### 3.2 DC Characteristics

Measurements at Recommended Operating Conditions unless otherwise specified.

Table 10: IDE Flash Drive DC Characteristics

Symbol	Parameter	Min	Max	Unit	Notes
VIL	Input LOW Voltage	-0.3	+0.8	V	VCC=3.3V or 5.0V
VIH	Input HIGH Voltage	2.0	VCC +0.3	V	VCC=3.3V or 5.0V
VOL	Output LOW Voltage		0.45	V	VCC=3.3V
			0.8		VCC=5.0V
VOH	Output HIGH Voltage	2.4		V	VCC=3.3V or 5.0V
ICC	Standby Mode		2	mA	ICC at VCC=3.3V or 5.0V
	Operating Current		75	mA	ICC at VCC=3.3V or 5.0V; Operating current measured with 2-way interleaving.
ILI	Input Leakage Current		10	µA	VCC=3.3V or 5.0V
ILO	Output Leakage Current		1	µA	VCC=3.3V
			2	µA	VCC= 5.0V
CI/O	Input/output Capacitance		25	pF	VCC=3.3V or 5.0V

### 3.3 AC Characteristics

Measurements at Recommended Operating Conditions, unless otherwise specified.

#### 3.3.1 True IDE Mode Register Access

Table 11: True IDE Mode Register Access AC Characteristics

Parameter	Symbol	Mode0	Mode1	Mode2	Mode3	Mode4	Mode5	Mode6	Unit
Cycle time (min)	t0	600	383	330	180	120	100	80	ns
Address valid to -IORD/-IOWR (min) setup	t1	70	50	30	30	25	15	10	ns
-IORD/-IOWR pulse width 8bit (min)	t2	290	290	290	80	70	65	55	ns
-IORD/-IOWR recovery time (min)	t2i	—	—	—	70	25	25	20	ns
-IOWR data setup (min)	t3	60	45	30	30	20	20	15	ns
-IOWR data hold (min)	t4	30	20	15	10	10	5	5	ns
-IORD data setup (min)	t5	50	35	20	20	20	15	10	ns
-IORD data hold (min)	t6	5	5	5	5	5	5	5	ns
-IORD data tristate (max)	t6z	30	30	30	30	30	20	20	ns
Addresses valid to -IOCS16 assert. (max)	t7	90	50	40	N/A	N/A	N/A	N/A	ns
Address valid to -IOCS16 release (max)	t8	60	45	30	N/A	N/A	N/A	N/A	ns
-IORD/-IOWR to address valid hold	t9	20	15	10	10	10	10	10	ns

### 3.3.2 True IDE Mode PIO Access

Table 12: True IDE Mode PIO Access AC Characteristics

Parameter	Symbol	Mode0	Mode1	Mode2	Mode3	Mode4	Mode5	Mode6	Unit
Cycle time (min)	t0	600	383	330	180	120	100	80	ns
Address valid to -IORD/-IOWR (min) setup	t1	70	50	30	30	25	15	10	ns
-IORD/-IOWR pulse width 8bit (min)	t2	290	290	290	80	70	65	55	ns
-IORD/-IOWR recovery time (min)	t2i	—	—	—	70	25	25	20	ns
-IOWR data setup (min)	t3	60	45	30	30	20	20	15	ns
-IOWR data hold (min)	t4	30	20	15	10	10	5	5	ns
-IORD data setup (min)	t5	50	35	20	20	20	15	10	ns
-IORD data hold (min)	t6	5	5	5	5	5	5	5	ns
-IORD data tristate (max)	t6z	30	30	30	30	30	20	20	ns
Addresses valid to -IOCS16 assert. (max)	t7	90	50	40	N/A	N/A	N/A	N/A	ns
Address valid to -IOCS16 release	t8	60	45	30	N/A	N/A	N/A	N/A	ns
-IORD/-IOWR to address valid hold	t9	20	15	10	10	10	10	10	ns

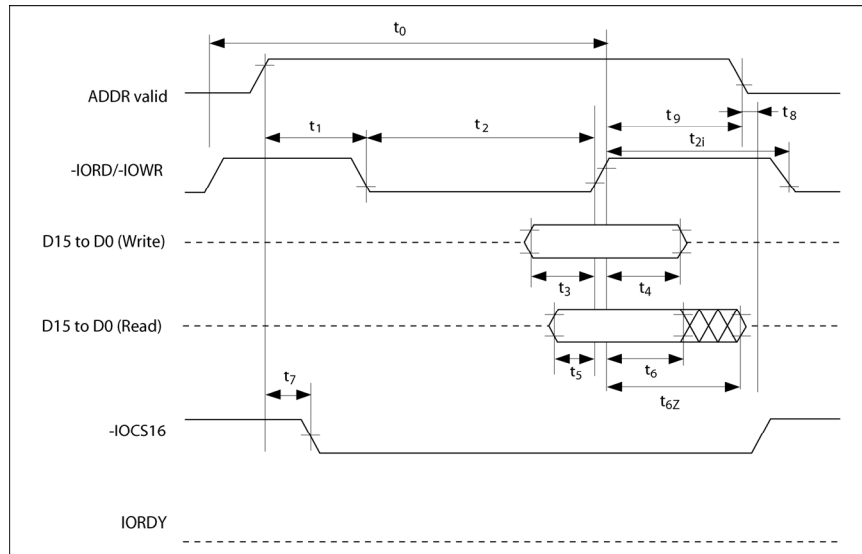

Figure 4: True IDE Mode Register and PIO Access Timing Diagram

### 3.3.3 True IDE Mode Multiword DMA

Table 13: True IDE Mode Multiword DMA AC Characteristics

Parameter	Symbol	Mode 0	Mode 1	Mode 2	Mode 3	Mode 4	Unit
Cycle time (min)	$t_0$	480	150	120	100	80	ns
-IORD/-IOWR Asserted Pulse (min)	$t_D$	215	80	70	65	55	ns
-IORD data access (max)	$t_E$	150	60	50	50	45	ns
-IORD data hold (min)	$t_F$	5	5	5	5	5	ns
-IORD/-IOWR data setup (min)	$t_G$	100	30	20	15	10	ns
-IOWR data hold (min)	$t_H$	20	15	10	5	5	ns
DMACK to -IORD/-IOWR setup (min)	$t_i$	0	0	0	0	0	ns
-IORD/-IOWR to DMACK hold (min)	$t_j$	20	5	5	5	5	ns
-IORD negated pulse width (max)	$t_{KR}$	50	50	25	25	20	ns
-IOWR negated pulse width (min)	$t_{KW}$	215	50	25	25	20	ns
-IORD to DMARQ delay (max)	$t_{LR}$	120	40	35	35	35	ns
-IOWR to DMARQ delay (max)	$t_{LW}$	40	40	35	35	35	ns

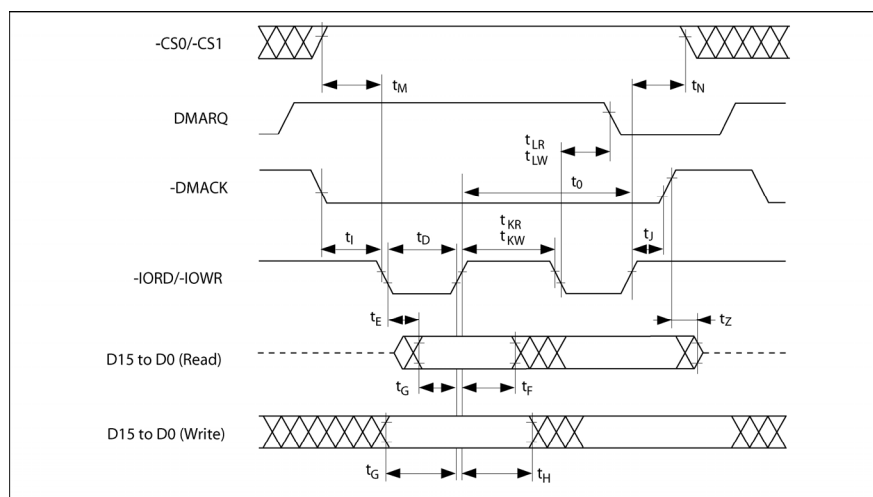

Figure 5: True IDE Mode Multiword DMA Timing Diagram

## 4.0 Identify Drive Parameter Information

An example of the parameter information received from the IDE Flash Drive when invoking the Identify Drive command (ECh) is listed in Table 14 below.

Table 14: Identify Drive Parameter Information

Word Address	Data	Total Bytes	Description
0	044AH	2	Value fixed by CFA
1	XXXXH	2	Default number of cylinders
2	0000H	2	Reserved
3	00XXH	2	Default number of heads
4	XXXXH	2	Do not use this word. Before retirement, was number of unformatted bytes per track
5	XXXXH	2	Do not use this word. Before retirement, was number of unformatted bytes per sector
6	XXXXH	2	Default number of sectors per track
7 - 8	XXXXH	4	Number of sectors per IDE Flash Drive (word 7 = MSW, word 8 = LSW)
9	0000H	2	Reserved
10 - 19	Unique per drive	20	Serial Number in ASCII (20 characters): STEC proprietary
20	XXXXH	2	Do not use this word. Before retirement, was buffer type
21	XXXXH	2	Do not use this word. Before retirement, was buffer size in 512 byte increments
22	0004H	2	# of ECC bytes passed on Read/Write Long commands
23 - 26	See description	8	Firmware revision in ASCII (8 characters): Rev8.0.0 52 65 76 38 2E 30 2E 30 hex
27 - 46	See description	40	Model Number in ASCII (40 characters): STI Flash 8.0.0 <left justified> 53 54 49 20 46 6C 61 73 68 20 38 2E 30 2E 30 20 hex
47	0001H	2	Maximum of 1 sector on Read/Write Multiple command
48	0000H	2	Double Word not supported
49	0300H	2	DMA supported, LBA supported
50	0000H	2	Reserved
51	0200H	2	PIO data transfer cycle timing mode
52	0000H	2	Single word DMA data transfer cycle timing mode (not supported)
53	0003h	2	Words 54 - 58 and 64 - 70 are valid
54	XXXXH	2	Number of Current Cylinders
55	XXXXH	2	Number of Current Heads
56	XXXXH	2	Number of Current Sectors Per Track
57	XXXXH	2	LSW of the Current Capacity in Sectors
58	XXXXH	2	MSW of the Current Capacity in Sectors
59	010XH	2	Current Setting for Block Count=1 for R/W Multiple commands
60 - 61	XXXXH	4	Total number of sectors addressable in LBA Mode
62	0000H	2	Single word DMA transfer not supported
63	0407H	2	Multiword DMA modes supported
64	0003H	2	Advanced PIO modes supported (modes 3 and 4)
65	0078H	2	Minimum multiword DMA transfer cycle time per word (ns)
66	0078H	2	Recommended multiword DMA transfer cycle time per word (ns)
67	0078H	2	Minimum PIO transfer without flow control
68	0078H	2	Minimum PIO transfer with IORDY flow control
69 - 255	0000H	374	Reserved

XXXXH = These values depend on the specific IDE Flash Drive.

## 5.0 Registers

This chapter lists the registers of the IDE Flash Drive. Refer to ATA/IDE standards for further details, including Task File Register mapping and bit definitions of each Task File Register.

The Data Register is accessed in word (16-bit) mode at power up. The IDE Flash Drive permits 8-bit accesses if the host issues a Set Feature Command to put the IDE Flash Drive in 8-bit mode.

Table 15: IDE Flash Drive Task File Registers

Task File Register	Description
Data Register	The Data Register is a 16-bit read/write register used for transferring data between the IDE Flash Drive and the host. This register can be accessed in word mode and byte mode.
Error Register	The Error Register is a read-only register that is used for analyzing an error. This register is valid when the BSY bit in the Status register and Alternate Status register are set to "0" (Ready). Diagnostic Codes are returned in the Error Register after a Execute Drive Diagnostic command (code 90h). Extended Error Codes returned in the Error Register after an Request Sense command (code 03h).
Sector Count Register	This register contains the numbers of sectors of data requested to be transferred on a read or write operation between the host and the IDE Flash Drive. If the value in the register is 0, a count of 256 sectors is indicated.
Sector Number Register	When the LBA bit in the Drive/Head register is 0, this register contains the starting sector number for any media access. When the LBA bit is set to 1, this register contains bits 7:0 of the LBA for any media access.
Cylinder Low Register	In CHS mode (LBA=0), this register contains the low-order bits of the starting cylinder address. In LBA mode, it contains bits 15:8 of the LBA.
Cylinder High Register	In CHS mode (LBA=0), this register contains the high-order bits of the starting cylinder address. In LBA mode, it contains bits 23:16 of the LBA.
Drive/Head Register	This register selects the IDE Flash Drive address translation (CHS or LBA) and provides head address (CHS) or high-order address bits 27:24 for LBA.
Status Register	This read-only register indicates status of a command execution. When the BSY bit is "0", the other bits are valid; when the BSY bit is "1", the other bits are not valid. When the register is read, the interrupt pin, is cleared.
Alternate Status Register	This register is the same as the Status register, except that is not negated when the register is read.
Device Control Register	This write-only register is used for controlling the interrupt request and issuing an ATA soft reset to the IDE Flash Drive.
Drive Address Register	This read-only register is used for confirming the IDE Flash Drive's status. This register is provided for compatibility with the AT disk drive interface and it is not recommended that this register be mapped into the host's I/O space because of potential conflicts on bit 7.
Command Register	This write-only register is used for writing the command that executes the IDE Flash Drive's operation. The command code is written in the command register after its parameters are written in the Task File during the IDE Flash Drive ready state.



## 6.0 Supported ATA Commands

The ATA commands used by the IDE Flash Drive are listed in Table 16 below. Refer to ATA/IDE standards for details.

Table 16: IDE Flash Drive Supported ATA Commands

Command Set	Code	Description
Check Power Mode	E5h or 98h	This command checks the power mode.
Execute Drive Diagnostic	90h	This command performs the internal diagnostic tests implemented by the IDE Flash Drive. The Diagnostic Code is returned in the Error Register.
Erase Sector(s)	C0h	This command is used to pre-erase and condition data sectors in advance.
Format Track	50h	This command writes the desired head and cylinder of the selected drive with a vendor unique data pattern (typically 00h or FFh). This IDE Flash Drive accepts a sector buffer of data from the host to follow the command with the same protocol as the Write Sector Command although the information in the buffer is not used.
Identify Drive	ECh	This command lets the host receive parameter information from the IDE Flash Drive in the same protocol as Read Sector(s) command.
Idle	E3h or 97h	This command causes the IDE Flash Drive to set BSY, enter the Idle mode, clear BSY, and generate an interrupt. If the sector count is non-zero, automatic power down mode is enabled. If the sector count is zero, the automatic power down mode is disabled.
Idle Immediate	E1h or 95h	This command causes the IDE Flash Drive to set BSY, enter the Idle mode, clear BSY, and generate an interrupt.
Initialize Drive Parameters	91h	This command enables the host to set the number of sectors per track and the number of heads per cylinder.
NOP	00h	No Operation.
Read Buffer	E4h	This command enables the host to read the current contents of the IDE Flash Drive's sector buffer.
Read DMA	C8h	This command is the sector read command used for Multiword DMA transfer.
Read Multiple	C4h	This command performs similarly to the Read Sectors command. Interrupts are not generated on each sector, but on the transfer of a block which contains the number of sectors defined by a Set Multiple command.
Read Long Sector	22h or 23h	This command performs similarly to the Read Sector(s) command except that it returns 516 bytes of data instead of 512 bytes.
Read Sector(s)	20h (w/ retry) 21h (w/o retry)	This command reads from 1 to 256 sectors as specified in the Sector Count register. A sector count of 0 requests 256 sectors. The transfer begins at the sector specified in the Sector Number register.

Command Set	Code	Description
Read Verify Sector(s)	40h (w/ retry) 41h (w/o retry)	This command verifies one or more sectors on the IDE Flash Drive by transferring data from the flash media to the data buffer in the IDE Flash Drive and verifying that the ECC is correct. This command is identical to the Read Sectors command, except that DRQ is never set and no data is transferred to the host.
Recalibrate	1Xh	The IDE Flash Drive performs only the interface timing and register operations. When this command is issued, the IDE Flash Drive sets BSY and waits for an appropriate length of time, after which it clears BSY and issues an interrupt. When this command ends normally, the IDE Flash Drive is initialized.
Request Sense (Extended Error)	03h	This command requests an extended error code after a command ends with an error. The extended error code is returned in the Error Register
Seek	7Xh	This command is effectively a NOP command to the IDE Flash Drive although it does perform a range check.
Set Features	EFh	This command is used by the host to establish or select certain features.
Set Multiple Mode	C6h	This command enables the IDE Flash Drive to perform multiple read and write operations and establishes the block count for these commands.
Set Sleep Mode	E6h or 99h	This is the only command that allows the host to set the IDE Flash Drive into Sleep mode. When the IDE Flash Drive is set to sleep mode, the IDE Flash Drive clears the BSY line and issues an interrupt. The IDE Flash Drive enters sleep mode and the only method to make the IDE Flash Drive active again (back to normal operation) is by performing a hardware reset or a software reset.
Stand By	E2h or 96h	This command sets the IDE Flash Drive in Standby mode. If the Sector Count Register is a value other than 0H, an Auto Power Down is enabled and when the IDE Flash Drive returns to the idle mode, the timer starts a countdown. The time is set in the Sector Count Register.
Stand By Immediate	E0h or 94h	This command causes the IDE Flash Drive to set BSY, enter the Standby mode, clear BSY and return the interrupt immediately.
Translate Sector	87h	This command allows the host a method of determining the exact number of times a user sector has been erased and programmed. This command is not supported.
Wear Level	F5h	This command is effectively a NOP command and only implemented for backward compatibility. The Sector Count Register will always be returned with an 00h indicating Wear Level is not needed.
Write Buffer	E8h	This command enables the host to overwrite the contents of the IDE Flash Drive's sector buffer with any data pattern desired.
Write DMA	CAh	This command is the sector write command used for Multiword DMA transfer.

Command Set	Code	Description
Write Long Sector	32h or 33h	This command is provided for compatibility purposes and is similar to the Write Sector(s) command except that it writes 516 bytes instead of 512 bytes.
Write Multiple	C5h	This command is similar to the Write Sectors command. Interrupts are not presented on each sector, but on the transfer of a block which contains the number of sectors defined by Set Multiple command.
Write Multiple w/o Erase	CDh	This command is similar to the Write Multiple command, except that an implied erase before the write operation is not performed. <b>Note:</b> Before using this command, it is required to erase the respective sectors using the Erase Sectors command
Write Sector(s)	30h (w/ retry) 31h (w/o retry)	This command writes from 1 to 256 sectors as specified in the Sector Count register. A sector count of zero requests 256 sectors. The transfer begins at the sector specified in the Sector Number register.
Write Sector(s) w/o Erase	38h	This command is similar to the Write Sector(s) command, except that an implied erase before the write operation is not performed. <b>Note:</b> Before using this command, it is required to erase the respective sectors using the Erase Sectors command.
Write Verify	3Ch	This command is similar to the Write Sector(s) command except each sector is verified immediately after being written.

## 7.0 Revision History

<b>Revision</b>	<b>Date</b>	<b>Description</b>
-101	11/20/06	Product release.
-102	12/14/06	ID file Serial Number, Firmware Revision, and Model Number corrected in table.
-103	1/16/07	Logo updated. Disclaimer updated. Contact Information added.
-104	2/23/07	In between capacities removed from Ordering Information and CHS parameters. Serial number revision (paper correction only).
-105	2/28/07	CSEL signal description corrected. 16GB CHS parameters added. DC Characteristics corrected
-106	4/10/07	Shock updated from 1K to 1.5K. Vibration updated from 15 to 20.
-107	5/21/07	Label section added.
-108	6/11/07	Connector location added to label section. Label added to dimension illustration.
-109	8/06/07	Warranty bullet removed from features column on page 1

STEC Inc. reserves the right to make changes to specifications and product descriptions such as, but not limited to, numbers, parameters and other technical information contained herein without notice. Contact STEC Inc. sales office to obtain the latest specification. All information in this document is provided "as is". STEC Inc. grants no warranty of any kind with respect to this document, either expressed or implied, including, but not limited to any direct, indirect, special, consequential, or incidental damages. Under no circumstances, including but not limited to negligence, shall STEC be liable for damages resulting from reliance on the information present in this document. Some States do not grant the exclusion of limitation of liability and as such this statement may not apply to you. The provisions of this datasheet do not convey to the purchaser of the device any license under any patent rights or other intellectual property rights of STEC Inc. or others. STEC prohibits the recipient of this information from the publication, transmission, or distribution of the information to any third party except as expressly permitted by STEC. STEC products are not authorized for use as critical component in life support devices or systems without express written approval of STEC, Inc.

The information provided may be subject to United States Export Controls. Such information should not be downloaded or exported (i). into (or to a national or resident of) Cuba, Iraq, Libya, North Korea, Iran, Syria, or any other country to which the United States has embargoed goods; or given to (ii). anyone on the United States Treasury Department's list of Specially Designated Nationals or the U.S. Commerce Department's Table of Deny Orders. By using the information, you represent and warrant that you are not located in, under the control of, or a national or resident of any such country or on any such list.

STEC™, Inc., reserves the right to change products or specifications without notice. ©2007 STEC™, Inc. All rights reserved.

**Worldwide  
Headquarters**  
3001 Daimler Street  
Santa Ana, California  
92705 USA  
Tel: (949) 476-1180  
Fax: (949) 476-1209  
[www.stec-inc.com](http://www.stec-inc.com)

**STEC Europe**  
Donau-City-Strasse 1  
1220 Vienna, Austria  
Tel: +43 1 263 38 08  
Fax: +43 1 263 37 65  
[www.stec-inc.com](http://www.stec-inc.com)

**STEC Hong Kong**  
Unit 01-02, 10/F  
88 Hing Fat Street  
Causeway Bay,  
Hong Kong  
Tel: +852-3150-8398  
Fax: +852-3150-8399  
[www.stec-inc.cn](http://www.stec-inc.cn)

**STEC Japan**  
Landmark Tower  
20/F 2-2-1, Minato-Mirai,  
Nishi-ku  
YOKOHAMA, 220-8120,  
Japan  
Tel: +81(0) 45-670-7030  
Fax: +81(0) 45-670-7001  
[www.stec-inc.jp](http://www.stec-inc.jp)

**STEC Taiwan**  
4F, No. 3, Lane 91,  
Dongmei Road  
Hsinchu City Taiwan  
Tel: +886-3-5733233  
Fax: +886-3-5733633  
[www.stec-inc.com](http://www.stec-inc.com)