



128MB to 4GB
Industrial Grade USB Flash Drive

SLUFDxxx(M/G)U1U(I)-y

Capacity: 128MB - 4GB

USB 2.0 Compliant

LED activity indicator

Customizable for logo/graphic design

High Reliability:

- Endurance Guarantee of 2,000,000 Write/Erase Cycles
- Built-in Wear-leveling
- 5 Bytes Detect/4 Bytes Correct EDC/ECC
- Automatic Bad Block Management
- Single Level Cell (SLC) NAND Flash Memory
- 10 Year Data Retention

NEBS Level 3 compliant for ESD

- 8KV Contact, 15KV Air

Lot Traceability

Commercial and Industrial Operating Temperature

RoHS-6 Compliant

General Description

STEC's Industrial Grade USB Flash Drive (UFD) is more than just portable storage. Tailored for industrial applications that require high reliability and data throughput, it provides non-volatile, industrial grade solid-state storage in a thumb-drive package. In addition, laser-etched manufacturing information allows for lot traceability and complete info on the Bill of Materials.

The Industrial Grade UFD is available in a Standard enclosure with LED light indicator, or an ESD-rated enclosure for applications that require NEBS Level 3 compliancy. The ESD-rated enclosure has been tested for immunity from ESD for 8KV contact and 15KV air.

STEC's proprietary state-of-the-art USB 2.0 flash memory controller is incorporated in the Industrial Grade UFD, providing high data integrity and endurance. The flash management software that is embedded in the controller emulates a hard disk, enabling read/write operations that are identical to a standard, sector-based hard disk. Sophisticated wear leveling algorithms guarantee 2,000,000 Write/Erase Cycles, while automatic bad block management and a built-in ECC Engine guarantee the highest data reliability. Based on the Reed-Solomon algorithm, the ECC engine can detect up to 5-byte errors and correct up to 4-byte errors per 512 bytes.

High performance, high reliability and a controlled Bill-Of-Materials make the Industrial Grade UFD the product of choice in industrial applications, such as POS Workstations, Networking Equipment, automotive diagnostics and Industrial PCs.

The UFD is fully customizable to add a company logo, graphic design or text, either by silk screen or laser etching. In addition, STEC offers value-added services to OEM customers, such as pre-loaded content, custom firmware, controlled Bill Of Materials, and serialization.

Ordering Information: USB Flash Drive

Part Number	UFD Form Factor	Capacity
SLUFD128MU1U(I)-y	y=A, B	128 MBytes
SLUFD256MU1U(I)-y	y=A, B	256 MBytes
SLUFD512MU1U(I)-y	y=A, B	512 MBytes
SLUFD1GU1U(I)-y	y=A, B	1 GBytes
SLUFD2GU1U(I)-y	y=A, B	2 GBytes
SLUFD4GU1U(I)-y	y=A, B	4 GBytes

Legend:

- **SLUFD** = STEC standard USB Flash Drive part number prefix.
- **(M/G)** = proceeding capacity (xxx) is in MBytes (M) or GBytes (G).
- **U1** = STEC U1 controller.
- **U** = RoHS-6 compliant
- **Part numbers without (I)** = Commercial Temperature Range (0°C to 70°C)
- **(I)** = Industrial Temperature Range (-40°C to +85 °C)
- **(y)** = A for Standard Enclosure, B for ESD-rated Enclosure

Table of Contents

General Description	1
Ordering Information: USB Flash Drive	1
1.0 Introduction.....	3
2.0 Product Specifications.....	4
2.1 Mechanical Dimensions.....	4
2.2 Pin Assignment and Description.....	6
2.3 Performance.....	6
2.4 LED Functionality.....	6
3.0 Theory of Operation	7
3.1 Block Diagram	7
3.1.1 Controller Internal Components	7
3.1.2 Controller external components	8
3.2 Flash Management.....	8
3.2.1 Bad Block Management.....	8
3.2.2 Wear Leveling	9
3.2.3 Error Correction/Detection	9
3.2.4 Power Failure Management	9
3.3 OS Support.....	10
3.4 Unique Serial Number	10
4.0 Environmental Specifications.....	11
4.1 Recommended Operating Conditions	11
4.2 Reliability	11
4.3 Shock, Vibration, and Humidity	11
4.4 Electrostatic Discharge (ESD).....	12
4.5 Mean Time Between Failure (MTBF)	12
4.6 Standards Compliance	12
5.0 Electrical Specifications	13
5.1 Absolute Maximum Ratings.....	13
5.2 DC Characteristics.....	13
5.3 AC Characteristics.....	14
6.0 Product Marking	15
6.1 Custom Product Marking.....	15
7.0 Revision History	16

1.0 Introduction

This datasheet includes the following sections:

- *Product Specifications* covers the most referenced specifications, such as mechanical dimension, signal description, and performance.
- *Theory of Operation* explains the Industrial Grade UFD block diagram and flash management features.
- *Environmental Specifications* characterizes the recommended operating conditions, reliability parameters and shock, vibration and humidity parameters.
- *Electrical Specifications* describes the absolute maximum ratings and AC/DC characteristics.
- *Product Marking* describes the marking on the USB Flash Drive.



Figure 1: Industrial Grade USB Flash Drive Family

2.0 Product Specifications

2.1 Mechanical Dimensions

Table 1, Figure 2 and Figure 3 show the mechanical dimensions of the Industrial Grade UFD with Standard enclosure and ESD-Rated Enclosure

Table 1: Mechanical dimension

Parameter	Standard enclosure	ESD-rated enclosure
Length	68.60 ± 0.25 mm (2.701 ± 0.010 in)	65.95 ± 0.25 mm (2.596 ± 0.010 in)
Width	18.60 ± 0.25 mm (0.732 ± 0.010 in)	16.50 ± 0.25 mm (0.654 ± 0.010 in)
Height	9.10 mm ± 0.25 mm (0.358 ± 0.010 in)	5.70 mm ± 0.25 mm (0.209 ± 0.010 in)

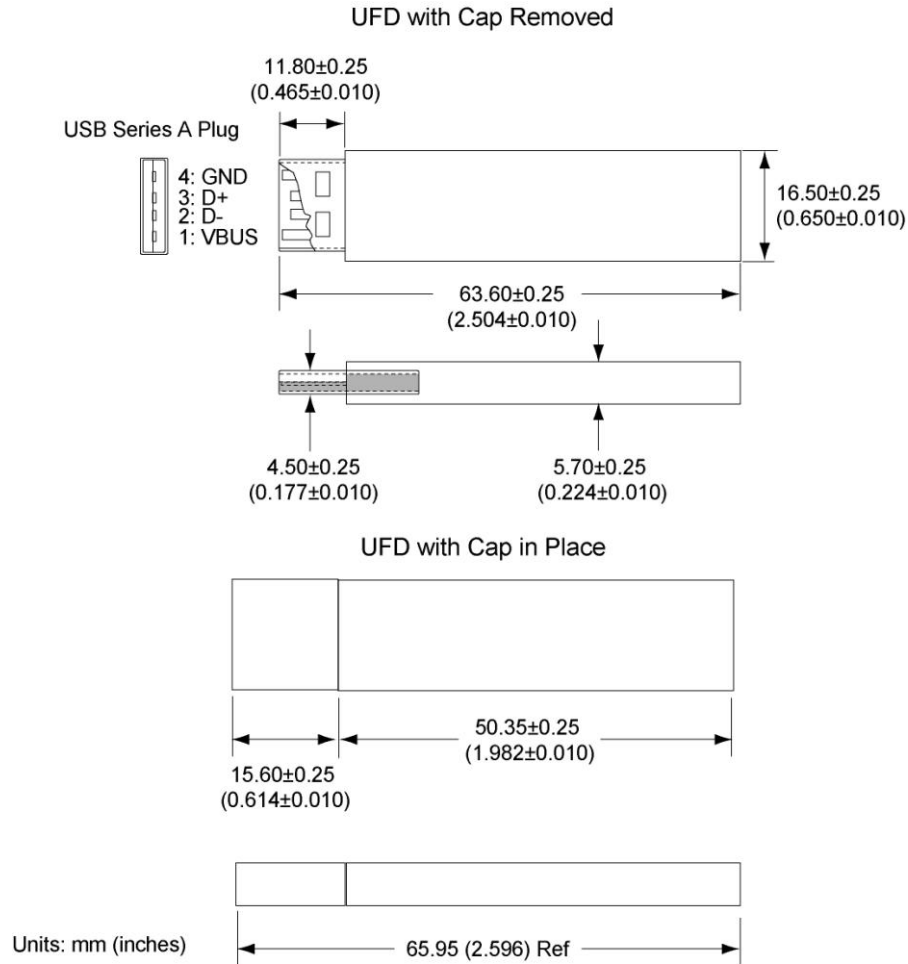

Figure 2: Mechanical dimensions-UFD ESD-Rated enclosure

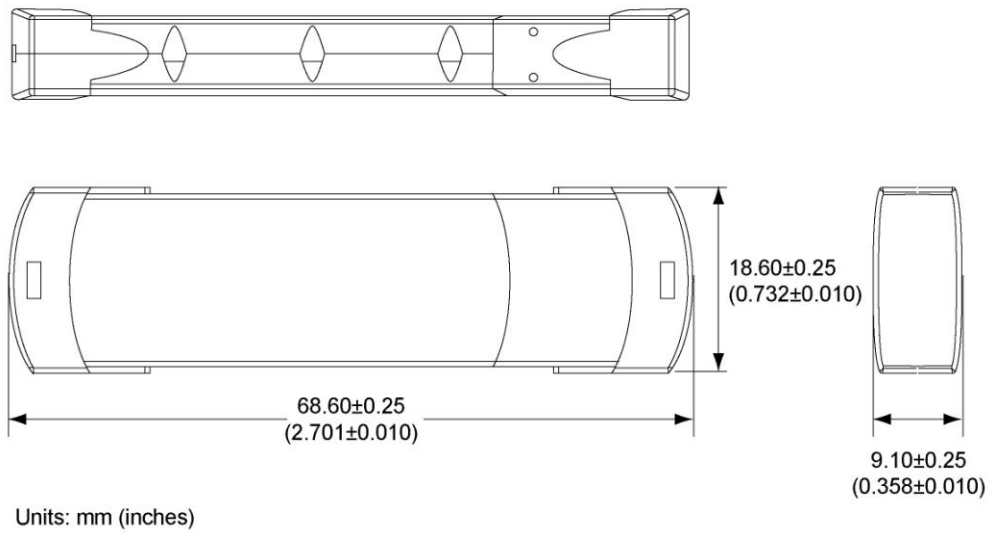

Figure 3: Mechanical dimensions-UFD Standard enclosure

2.2 Pin Assignment and Description

Table 2: Pin Assignment and Description

Pin Number	Signal Name	Type	Description
1	VBUS	Power	Bus voltage supply
2	D-	I/O	Data line –
3	D+	I/O	Data line +
4	GND	Ground	Ground

2.3 Performance

The Industrial Grade UFD is USB 2.0 high-speed (480Mb/sec) and USB 1.1 full-speed (12Mb/sec) compliant. Measured performance in both modes can be found in Table 3.

Table 3: Read/Write Performance

Parameter	USB 1.1 Full Speed	USB 2.0 High Speed
Sustained Read	Up to 1MB/sec	up to 14 MB/sec
Sustained Write	Up to 0.9MB/sec	up to 12 MB/sec

2.4 LED Functionality

The Industrial Grade UFD with standard enclosure incorporates a LED activity indicator that functions as described below:

- LED flashing slowly: Industrial Grade UFD is connected and inactive
- LED flashing rapidly: Industrial Grade UFD is transmitting/receiving data or is identification process
- Default LED colors: Blue

3.0 Theory of Operation

3.1 Block Diagram

The Industrial Grade UFD uses STEC's proprietary state-of-the art USB 2.0 controller, combined with SLC NAND Flash for optimal device reliability. The controller's firmware supports the latest NAND flash technology from multiple vendors, and is optimized for the highest performance and reliability.

The USB controller consists of the functional blocks as shown in Figure 4. The blocks are described in the paragraphs following the figure.

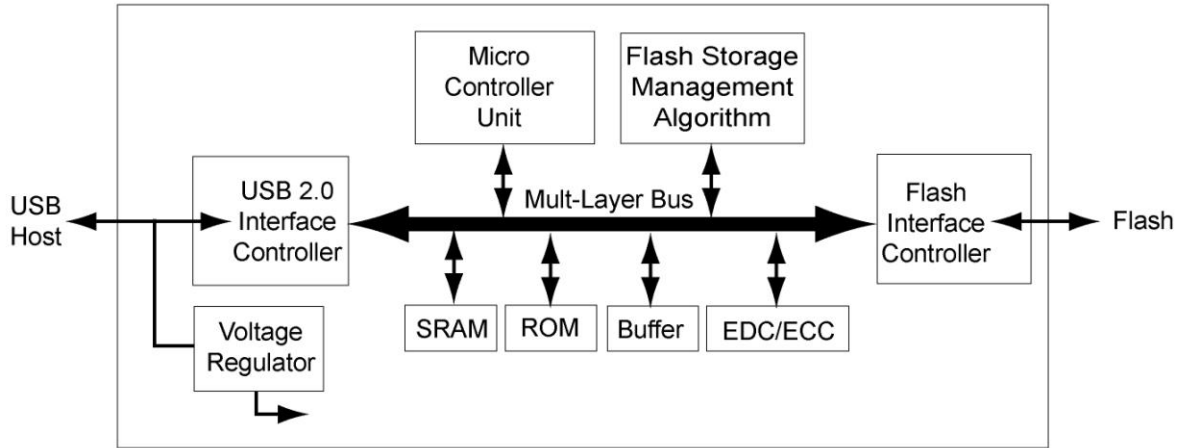

Figure 4: Controller block diagram

3.1.1 Controller Internal Components

- *Microcontroller* which serves as the hardware backbone for the flash controller algorithm.
- *USB 2.0 Interface Controller* with high speed (480 Mbps) device function. This block interfaces with the host system via the USB interface.
- *Flash Interface Controller* that serves as the interface to the NAND flash components. It supports all the major NAND flash memory manufacturers.
- *Flash Storage Management Algorithm Block* is responsible for the flash management, including wear leveling, bad block management, and Error Detection and Correction.
- *EDC/ECC* block is responsible for on-the-fly error detection and correction.
- *Sector Buffer* for optimized performance.
- *SRAM* for running controller firmware fast and efficient.
- *ROM* for storing controllers boot code.

3.1.2 Controller external components

In addition to the functional blocks shown in Figure 4, the Industrial Grade UFD has the following external components:

- *SLC NAND Flash* for the most reliable data storage.
- *Crystal Oscillator 12Mhz*, as the main clock source.

3.2 Flash Management

Since the Industrial Grade UFD provides a standard USB interface to the host, no software integration is required, providing the shortest time-to-market for design engineers.

The firmware of the embedded USB 2.0 controller contains STEC's advanced flash memory management algorithms to ensure the most optimum device performance, reliability and endurance. It was designed to maximize the benefits of flash memory, while at the same time overcoming inherent NAND flash limitations. Implemented in firmware are the below features:

- Flash file system management
- Bad-block management
- Wear-leveling
- Power failure management
- Performance optimization

3.2.1 Bad Block Management

Inherent to NAND flash technology are areas (blocks) on the media that cannot be used for storage because of their high error rate. These so-called "bad blocks" are already identified by the flash vendor during manufacturing, but can also be accumulated over time during device operation.

The Mach1 controller contains a table that lists all the bad blocks on the device (Bad Block Table), and automatically maps out these blocks upon system initialization. During device operation it ensures that newly accumulated bad blocks are also mapped out and added to the Bad Block Table.

Bad block management is 100% transparent to the host application, which will not be aware of the location or existence of bad blocks on the media.

3.2.2 Wear Leveling

The SLC NAND flash devices that are being used in the USB Flash Drive are guaranteed for 100,000 Write/Erase cycles per block. This means that after approximately 100,000 erase cycles, the erase block has a higher probability for errors than the error rate that is typical to the flash. While 100,000 write/erase cycles may be good for consumer data storage, such as digital cameras, MP3 players, etc., it is not sufficient for industrial and embedded applications where data is constantly written to the device and long product life is required.

For example, operating systems that use a file system, will update the File Allocation Table (FAT) every time a write is done to the device. Without any wear leveling in place, the area on the flash where the FAT table is located would wear out faster than other areas, reducing the lifetime of the entire flash device.

To overcome this limitation, the flash management algorithm needs to make sure that each block in the device ages, i.e. is "worn out", at the same rate. The built-in wear leveling scheme makes sure that with every write to the flash, the youngest block is used. This ensures that the full flash media is used uniformly, so that one area of the flash will not reach the endurance limits prematurely before other areas. The implemented wear leveling algorithm ensures a minimum of 2 million write/erase cycles for the entire flash media.

3.2.3 Error Correction/Detection

The USB 2.0 controller implements an advanced Error Correction/Detection scheme, based on the Reed-Solomon algorithm. The ECC engine can detect up to 5 bytes and correct up to 4 bytes per 512 bytes (symbol based). To ensure the fastest performance, both detection and correction are done on-the-fly, in hardware only.

Each time the host application writes a sector of 512 bytes to the Industrial Grade UFD, a unique ECC signature is created by the ECC engine and written together with the data to the flash. When the data is read back by the host, the ECC engine creates again a unique ECC signature. It will then compare the original written signature with the newly created signature, and sets an error flag if the two signatures are not the same. Correction of the data is done on-the-fly when the error flag is set, and the data presented to the host will be the same as the original written data. This powerful Error Correction/Detection scheme results in an overall error rate of less than 1 in 10^{14} bits, read.

3.2.4 Power Failure Management

The embedded flash management software uses algorithms that ensure data integrity, even during power failures. After each write, a *verify write flag* is set in the extra area of the flash page, while a *dismount flag* is set for the whole device during regular power-down. When a power failure occurs, both the *verify write* and the *dismount flag* will not be set, indicating a power failure during a write or erase operation. Upon the next power-up, the mapping tables will be reconstructed from the information stored in the flash memory, and the last version of the sector with a correct *verify write flag* will be used.

This mechanism ensures complete data integrity. When writing, copying, or erasing the flash device, the data format remains valid at all intermediate stages. Old data is never erased until the *verify write flag* of the new sector has been set. Therefore, a data sector cannot exist in a partially written state. The operation is either successfully completed (*verify write flag* is set) and the new data is valid, or the operation has not yet been completed or has failed, in which case the old sector contents remain valid.

3.3 OS Support

The Industrial Grade UFD is recognized as a removable drive and supports the following Operating Systems, as listed in Table 4.

Table 4: Supported Operating Systems

Operating System	Version
Windows 98/2000/XP	
Windows XP Embedded	
Windows CE	4.2 and 5.0
Windows for POS (WEPOS)	
VxWorks	
Linux	Kernel 2.4 and up

Note: Windows 98 requires driver.

3.4 Unique Serial Number

During manufacturing stage, a unique serial number is written to the USB Flash Drive that includes a date code related to the time of manufacturing. The serial number uses the following format: STI[N][S][YY][DDD][HHMMSS]. Table 5 describes the parameters of the serial number.

Table 5: Unique Serial Number format

Symbol	Parameter
STI	STEC vendor symbol
N	Number of Test Tower
S	Number of USB socket in Test Tower
YY	Year
DDD	Day of Year (1-365)
HHMMSS	Hours, Minutes, Seconds

The Serial Number can be obtained through Windows Device Manager or Linux utility lspci.

4.0 Environmental Specifications

4.1 Recommended Operating Conditions

Table 6: Recommended Operating Conditions

Parameter	Symbol	Min	Typ	Max	Unit
Commercial Operating Temperature	T _A	0	25	70	°C
Industrial Operating Temperature	T _A	-40	-	85	°C
Bus Voltage	V _{BUS}	4.75	-	5.25	V

4.2 Reliability

Table 7: Endurance & Data Reliability

Parameter	Value
Endurance	2,000,000 Write/Erase Cycles
Data reliability	1 in 10 ¹⁴ bits, read
Data retention	10 years
Durability	1500 insertions/removals

4.3 Shock, Vibration, and Humidity

Table 8: Shock, Vibration & Humidity

Parameter	Value
Shock	1500G Peak, 0.5m pulse duration, 5 pulses, 6 axes (per JESD22-B110)
Vibration	20G Peak, 20-2000 Hz, 4 cycles per direction (X, Y and Z) (per JESD22-B103)
Humidity	85°C, 85% RH, Vmax for 500 hrs (per JESD22-A101)

4.4 Electrostatic Discharge (ESD)

The Industrial Grade UFD has been tested for immunity from ESD under the conditions described in Table 9.

Table 9: Electrostatic Discharge for UFD

ESD Type	Standard Enclosure (Maximum Discharge)	ESD Rated Enclosure (Maximum Discharge)
Contact	4KV	8KV
Air	4KV	15KV

4.5 Mean Time Between Failure (MTBF)

STEC estimates Mean Time Between Failure (MTBF), using a prediction methodology based on reliability data for the individual components in the USB Flash Drive. Table 10 summarizes the prediction results for the USB Flash Disk Drive, based on the following two methodologies:

- Telcordia Special Report SR-332, Reliability Prediction Procedure for Electronic Equipment.
- MIL-HNBK-217

The analysis was performed using Relux Software.

Table 10: USB Flash Drive MTBF

Product	Condition	MTBF (hours)
SLUFD128MU1U-A	Telcordia SR-332, GB, 25°C MIL-HNBK-217	>8,000,000
SLUFD4GU1U-A	Telcordia SR-332, GB, 25°C MIL-HNBK-217	>8,000,000

4.6 Standards Compliance

USB Flash Drive complies with the following standards:

- CE - EN 55022/55024
- FCC - Class B for Information Technology
- UL 60950
- RoHS-6
- USB 2.0 – Mass Storage Class

5.0 Electrical Specifications

5.1 Absolute Maximum Ratings

Table 11: Absolute Maximum Ratings

Parameter	Symbol	Value	Unit
Power Supply Voltage Relative to Ground	V_{BUS}	-0.5 to 6V	V
Voltage on D+ and D- Relative to Ground	V_{DATA}	-0.5 to 3.6	V
Ambient Operating Temperature (Commercial)	T_A	0 to +70	°C
Ambient Operating Temperature (Industrial)	T_A	-40 to +85	°C

5.2 DC Characteristics

Measurements at Recommended Operating Conditions, unless otherwise specified.

Table 12: DC Characteristics for Full-Speed Operation ($T_A=25^\circ\text{C}$, $V_{dd}=5\text{V}$, $V_{ss}=0\text{V}$)

Parameter	Symbol	Test conditions	Min	Typ	Max	Unit
Supply Voltage	V_{BUS}		4.75	5	5.25	V
Operating current	I_{CC}	$V_{BUS}=5.0\text{V}$	60	-	90	mA
Suspend current	I_{CCS}	$V_{BUS}=5.0\text{V}$	320	-	500	μA
Input LOW Voltage	V_{IL}		-	-	0.8	V
Input HIGH Voltage	V_{IH}		2.0	-	-	V
Output LOW Voltage	V_{OL}	R_L of 1.5k Ω to 3.6V	-	-	0.3	V
Output HIGH Voltage	V_{OH}	R_L of 15k Ω to GND	2.8	-	3.6	V
Output Signal Crossover Voltage	V_{CRS}		1.3	-	2.0	V

Table 13: DC Characteristics for High-Speed Operation ($T_A=25^\circ\text{C}$, $V_{dd}=5\text{V}$, $V_{ss}=0\text{V}$)

Parameter	Symbol	Test conditions	Min	Typ	Max	Unit
Supply Voltage	V_{BUS}		4.75	5	5.25	V
Operating current	I_{cc}	$V_{BUS}=5.0\text{V}$	120	-	150	mA
Suspend current	I_{ccs}	$V_{BUS}=5.0\text{V}$	320	-	500	μA
High Speed Idle Level	V_{HSOI}		-10	-	10	mV
High Speed Data Signaling High	V_{HSOH}		360	-	440	mV
High Speed Data Signaling Low	V_{HSOL}		-10	-	10	mV
Chirp J Level (differential Voltage)	V_{CHIRPJ}		0.7	-	1.1	V
Chirp K Level (differential Voltage)	V_{CHIRPK}		-0.9	-	-0.5	mV

5.3 AC Characteristics

Measurements at Recommended Operating Conditions, unless otherwise specified.

Table 14: AC Characteristics Full Speed

Parameter	Symbol	Min	Typ	Max	Unit
Rise Time	T_{FR}	4	-	20	ns
Fall Time	T_{FF}	4	-	20	ns
Differential Rise and Fall Time Matching	T_{FRFM}	90		111.11	%
Driver Output Resistance	Z_{DRV}	28	-	44	Ω

Table 15: AC Characteristics High Speed

Parameter	Symbol	Min	Typ	Max	Unit
Rise Time (10%~90%)	T_{HSR}	500	-	-	ps
Fall Time (10%~90%)	T_{HSF}	500	-	-	ps
Driver Output Resistance	Z_{HSDRV}	40.5	-	49.5	Ω

6.0 Product Marking

USB Flash Drive will be shipped with manufacturing info laser etched onto the device, thereby providing the option for lot traceability and full access to the Bill of Material. Figure 5 shows the product marking for both enclosures of the UFD.

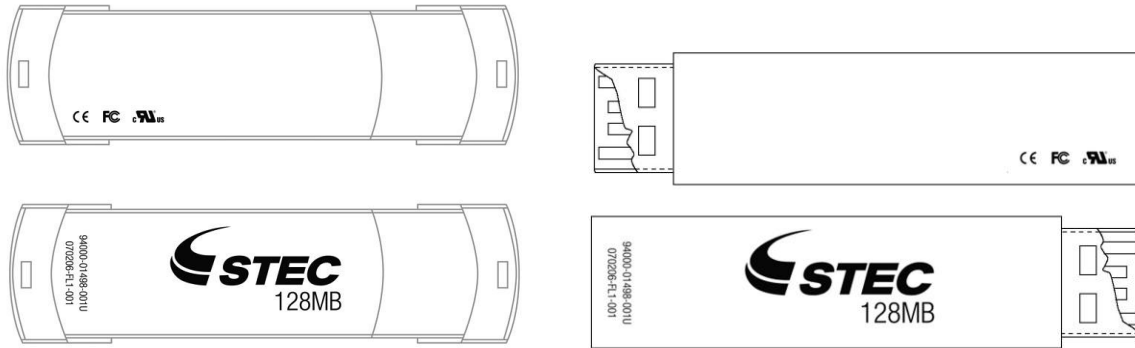

Figure 5: UFD Product Marking

The front side of the USB Flash Drive shows the Kanban ID and BOM Assembly Number; the back side shows standards logos for which the UFD was certified. Table 16 lists in detail what info can be obtained from the manufacturing information that is laser etched into the device.

Table 16: Manufacturing Info

Kanban ID yymmdd-XXX-xxx	Description	BOM Assembly Number 94000-ppppp-nnnTP	Description
yymmdd	Date code of manufacturing	94000*	STEC designation for OEM Flash products
XXX	SMT Line at which the part was manufactured	ppppp	PCB number
xxx	lot code	nnn	Capacity designator

Note: If custom P/N was set up, then 94000 will be replaced with custom BOM Assembly Number designator.

6.1 Custom Product Marking

STEC provides the option to mark the device with a company logo, graphic design or text, either by silk screen or laser etching.

7.0 Revision History

Revision	Date	Description
-101	12/8/06	Initial release.
-102	2/16/07	Updated all references from SimpleTech to STEC. Added mechanical dimensions for ESD-rated enclosure (Figure 2). Updated ESD Ratings for standard enclosure (Table 9). Added Section 0 on Unique Serial Number, section 4.6 on Standards Compliance, and section 6.0 on Product Marking.
-103	03/16/07	Added section for Mean Time Between Failure (Section 4.5). Added mechanical drawing of ESD-rated Enclosure UFD, updated parameters in Absolute Maximum Ratings (Table 11).
-104	4/27/07	Corrected mechanical dimensions in Table 1, corrected ESD Ratings for standard enclosure (Table 9).
-105	5/16/07	Added additional MTBF Calculations (Table 10). Product released. Password protection was not included in release, reference to this was taken out of datasheet.
-106	8/06/07	Warranty bullet removed from features column on page 1
-107	3/7/08	Contact information on last page updated.
-108	4/2/08	STEC China address on last page updated.

DISCLAIMER OF LIABILITY

STEC™ Inc. reserves the right to make changes to specifications and product descriptions such as but not limited to numbers, parameters and other technical information contained herein without notice. Please contact the STEC™ Inc. sales office to obtain the latest specifications. STEC™ Inc. grants no warranty with respect to this datasheet, neither explicit or implied, and is not liable for direct or indirect damages. Some states do not grant the exclusion of incidental damages and as such this statement may not be valid in such states. The provisions of the datasheet do not convey to the purchaser of the device any license under any patent rights or other intellectual property rights of STEC Inc. or others.

EXPORT ADMINISTRATION REGULATIONS

The information provided may be subject to United States Export Controls. Such information should not be downloaded or exported (i), into (or to a national or resident of) Cuba, Iraq, Libya, North Korea, Iran, Syria, or any other country to which the United States has embargoed goods; or given to (ii), anyone on the United States Treasury Department's list of Specially Designated Nationals or the U.S. Commerce Department's Table of Deny Orders. By using the information, you represent and warrant that you are not located in, under the control of, or a national or resident of any such country or on any such list.

COPYRIGHT NOTICE

Copyright © 2007 by STEC™ Inc. All rights reserved. Information contained in this document, including but not limited to any instructions, descriptions and product specifications, is considered proprietary and confidential to STEC™, Inc. and shall not be modified, used, copied, reproduced or disclosed in whole or in part, in any form or by any means, electronic or mechanical, for any purpose, without the written consent of STEC™ Inc.

Worldwide Headquarters

STEC, Inc.
3001 Daimler Street
Santa Ana, California 92705 USA
Tel: (949) 476-1180
Fax: (949) 476-1209
www.stec-inc.com/

STEC Europe

Donau-City-Strasse 1
1220 Vienna, Austria
Tel: +43 1 263 38 08
Fax: +43 1 263 37 65
www.stec-inc.com/

STEC Japan

Arents Daikanyama 114
11-1 Hachiyama-cho
Shibuya-ku, Tokyo
150-0035 Japan
Tel: +81(0) 3-5428-2231
Tel: +81(0) 3-5489-0230
www.stec-inc.jp/

STEC Malaysia

STEC Technology Sdn Bhd
Plot 107 Bayan Lepas Industrial Park
Phase 4, 11900 Penang, Malaysia
Tel: +60 (4)-6198888
www.stec-inc.com/

STEC China

RM1805, 18F Bund Centre
222 Yan An Rd East
HuangPu District
Shanghai, 200002.
P R. China
Tel: +86 21 6132 3892 * 629
Fax: +86 21 6335 1336
www.stecchina.cn/