

**NOTE** All numerical values are in metric units [with U.S. customary units in brackets]. Dimensions are in millimeters [and inches]. Unless otherwise specified, dimensions have a tolerance of  $\pm 0.13$  [ $\pm .005$ ] and angles have a tolerance of  $\pm 2^\circ$ . Figures and illustrations are for identification only and are not drawn to scale.

**1. INTRODUCTION**

This specification covers the requirements for application of PIDG terminals, splices, and end caps in various operating environments. Each consists of a precision-formed metal wire barrel and a copper sleeve encased in insulating material made of nylon, polyvinyl chloride (PVC) or polyvinyl fluoride (PVF<sup>2</sup>). The insulation is color coded (solid primary color or a primary color with a color stripe) to correspond with a specific wire size or wire size range. The terminals, splices, and end caps accept a combination of solid and stranded wire. The wire barrel contains serrations that provide maximum contact and tensile strength after crimping the terminal, splice, or end cap onto the wire. The terminals are available with a variety of tongue lengths and configurations; and the terminals, splices, and end caps are available with various wire barrel lengths and diameters to accommodate different wire sizes, wire types, and combination of wire sizes.

The terminals, splices, and end caps are available in loose piece form to be terminated with manual and pneumatically-powered hand held tools and tape mounted to be terminated with bench mount semi-automatic machines.

When corresponding with Tyco Electronics Personnel, use the terminology provided in this specification to facilitate your inquiries for information. Basic terms and features of this product are provided in Figure 1.

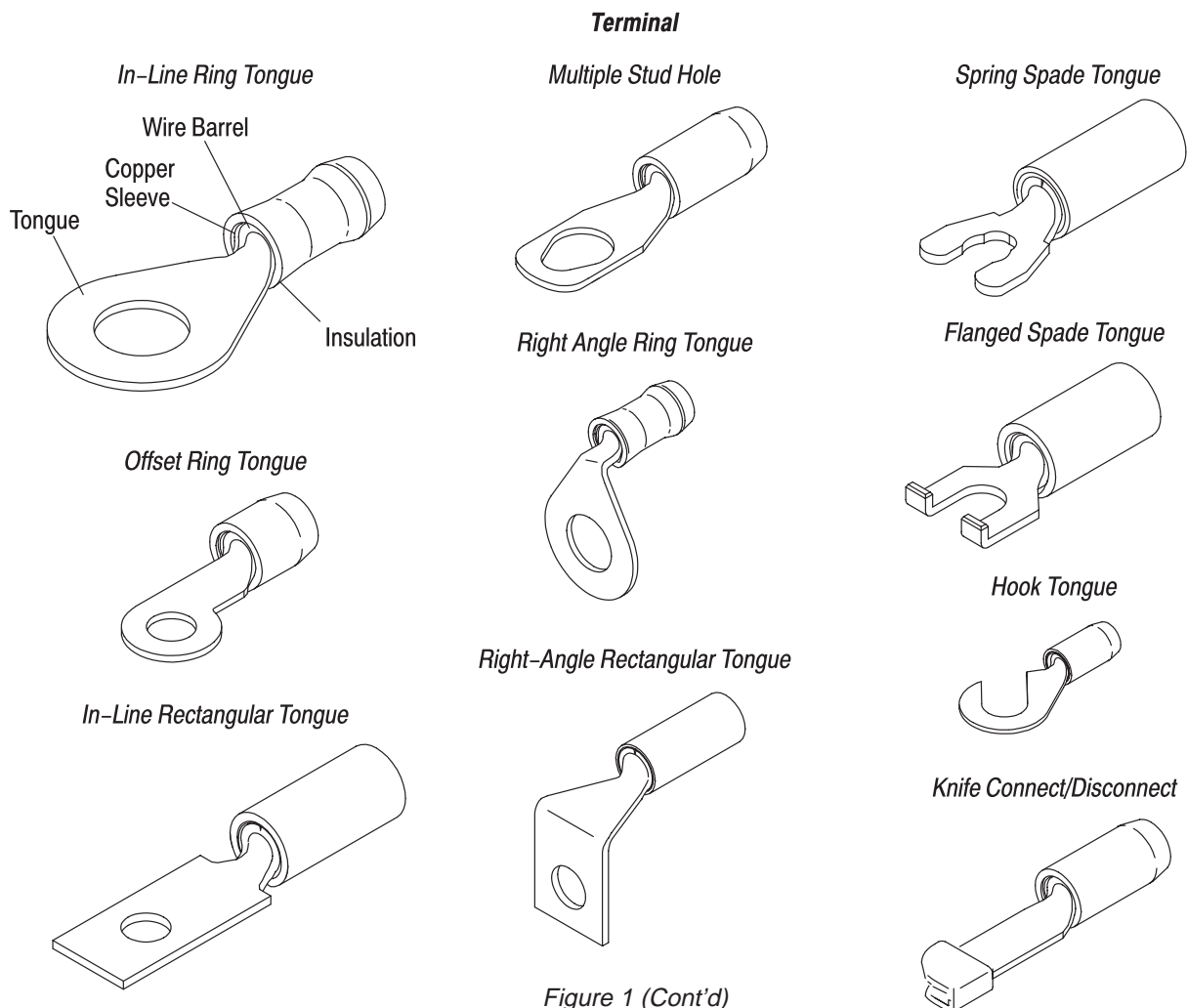

Figure 1 (Cont'd)

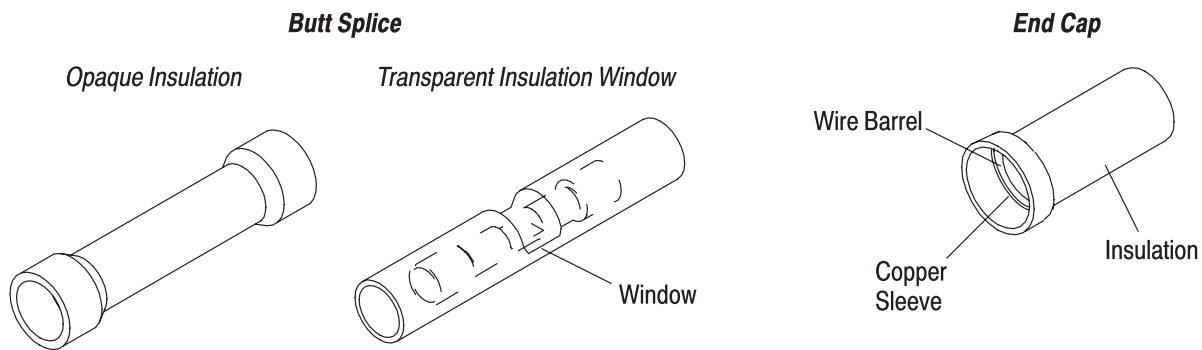

Figure 1 (End)

## 2. REFERENCE MATERIAL

### 2.1. Revision Summary

Revisions to this application specification include:

- Updated document to corporate requirements
- Changed text in Section 1, INTRODUCTION and Paragraphs 3.4, 3.8,
- Switched Paragraphs 3.5.C and 3.5.D
- Moved part of Paragraph 3.6 to new Paragraph 3.5.I
- Changed artwork, tables, or callouts in Figures 4, 10, and 11
- Added new text to Paragraph I and new callouts to Figure 6 and renumbered
- Moved old Figure 6 to Figure 11

### 2.2. Customer Assistance

Reference Product Base Part Number 51864 and Product Code 3022 are representative of PIDG terminals, splices, and end caps. Use of these numbers will identify the product line and expedite your inquiries through a service network established to help you obtain product and tooling information. Such information can be obtained through a local Representative or, after purchase, by calling PRODUCT INFORMATION at the number at the bottom of page 1.

### 2.3. Drawings

Customer Drawings for product part numbers are available from the service network. If there is a conflict between the information contained in the Customer Drawings and this specification or with any other technical documentation supplied, call PRODUCT INFORMATION at the number at the bottom of page 1.

### 2.4. Specifications

Product Specification 108-11023 provides test and performance results for insulated terminals and splices for Class 1 E Nuclear applications.

### 2.5. Instructional Material

Instruction Sheets (408-series) provide product assembly instructions or tooling setup and operation procedures and Customer Manuals (409-series) provide machine setup and operation procedures. Documents available which pertain to this product are:

- 408-1261 Hand Crimping Tools 59239-4 and 59287-2
- 408-1559 Hand Crimping Tools 46121, 47386, and 47387
- 408-1610 "T"-Head Crimping Tools 59250 and 59275
- 408-1632 Terminal and Splice Crimping Dies 69344, 47806-2, 47807-1, 47808-5, and 47808-6
- 408-2095 Hand Crimping Tool 69710-1
- 408-2423 Crimping Die Assemblies for Tape-Mounted PIDG Terminals and Splices
- 408-2498 Crimping Head Cross Reference for Pneumatic Tools
- 408-2822 Crimping Die Assemblies 59826-1, 59827-1, and 59828-1

- 408-2823 TETRA-CRIMP\* Hand Crimping Tool 59824-1
- 408-3295 Preparing (Reel-Wrap) Reel of Contacts for Applicator Tooling
- 408-4099 Pneumatic TETRA-CRIMP Adapter 679305-1
- 408-4105 626 Straight Action Crimper 217200-[ ]
- 408-7424 Checking Terminal Crimp Height or Gaging Die Closure
- 408-8044 Miniature Quick-Change Applicator for Tape-Mounted Closed Barrel Terminals
- 408-8053 Miniature Quick-Change Applicators
- 408-8082 Miniature Quick-Change Applicators (Side-Feed Type) with Air Feed
- 408-8088 Applicator 818057-2
- 408-9252 PRO-CRIMPER\* Hand Crimping Tool 58433-3
- 408-9491 AUTO-PRO\* Terminating Machine 818380-1
- 408-9586 Pneumatic Crimping Heads 314269-1, 314270-3, and 314537-1
- 408-9640 Crimp Quality Monitor Applicators for Side-Feed and End-Feed Applications
- 408-9816 Handling of Reeled Products
- 409-1993 AMP-TAPETRONIC\* Machine 69875
- 409-5842 AMP-O-ELECTRIC\* Model "G" Terminating Machine 354500-1
- 409-5862 626 Pneumatic Tooling Assemblies 189721-[ ]
- 409-5878 AMPOMATOR\* CLS IV+ Lead-Making Machines 356500-[ ]

**3. REQUIREMENTS**

**3.1. Limitation**

These terminals and end caps are suitable for 300 volts maximum, and the splices are suitable for 600 volts maximum.

The terminals, splices, and end caps having the following insulation can withstand the following temperature range:

- nylon -40° to 105°C [-40° to 221° F]
- PVC -10° to 90°C [14° to 194° F]
- PVF<sup>2</sup> -65° to 150°C [-149° to 302° F]

**3.2. Storage**

**A. Ultraviolet Light**

Prolonged exposure to ultraviolet light may deteriorate the chemical composition used in the insulation.

**B. Reel Storage**

Tape-mounted reeled product should be stored horizontally to prevent sagging and possible stretching or distortion of the plastic tape which could adversely affect feeding of the product through the tooling.

**C. Shelf Life**

The product should remain in the shipping containers until ready for use to prevent inadvertent damage. The product should be used on a first in, first out basis to avoid storage contamination that could adversely affect signal transmissions.

**D. Chemical Exposure**

Do not store product near chemicals listed below. They could cause stress corrosion cracking of product.

Alkalies	Ammonia	Citrates	Phosphates	Citrates	Sulfur Compounds
Amines	Carbonates	Nitrites	Sulfur Nitrites		Tartrates

**3.3. Wire Selection and Preparation**

Terminals and splices accept solid and/or stranded wire sizes 26 through 10 AWG and end caps accept solid and/or stranded wire sizes 22 through 10 AWG. The wire size used must be within the range stamped on the underside of the terminal tongue or on the center of the splice or end cap. Generally, the strip length of the wire should be equal to the wire barrel length plus 0.76 [.030]. Specific strip lengths are given in Figure 2.

**NOTE** *The wire conductor(s) must not be nicked, scraped, or cut during the stripping operation.*

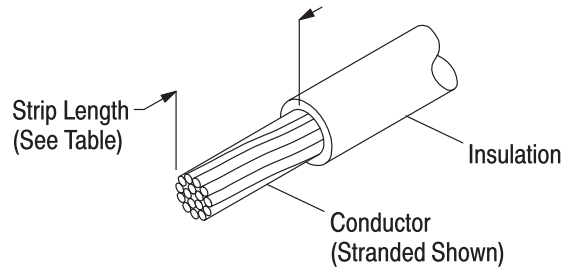

**Note:** Not to Scale

WIRE		TERMINAL, SPLICE, OR END CAP INSULATION COLOR	WIRE STRIP LENGTH		
SIZE (AWG)	DIAMETER RANGE		TERMINAL	SPLICE	END CAP
26	0.66-1.40 [.026-.055]	Yellow/Black	6.35-7.14 [.250-.281]	—	—
26-24	Multiple■	Yellow	5.16-5.94 [.203-.234]	4.37-5.16 [.172-.203]	—
26-22	Multiple■	Yellow	3.96-4.78 [.156-.188]	4.37-5.16 [.172-.203]	—
24	0.79-1.40 [.031-.055]	Yellow/Blue	4.78-5.56 [.188-.219]	—	—
24†			6.35-7.14 [.188-.281]	—	—
24-20	Multiple■	White	4.78-5.56 [.188-.219]	5.56-6.35 [.219-.250]	—
		Natural/White			
22	0.97-2.79 [.038-.110]	Red/Green	6.35-7.13 [.250-.281]	—	—
22-16	Multiple■	Red	5.16-5.94 [.203-.234]	6.35-7.13 [.250-.281]	7.95-8.74 [.313-.344]
		Natural/Red			—
20	1.17-2.79 [.046-.110]	Red/Red	6.35-7.13 [.250-.281]	—	—
18	1.42-2.79 [.056-.110]	Red/White	6.35-7.13 [.250-.281]	—	—
16	1.60-3.30 [.063-.130]	Blue/Blue	6.35-7.13 [.250-.281]	—	—
16-14	Multiple■	Natural/Blue	5.16-5.94 [.203-.234]	6.35-7.13 [.250-.281]	—
		Blue			7.95-8.74 [.313-.344]
16-14●	Multiple■	Yellow/Black	7.93-8.71 [.312-.343]	—	—
14	1.98-3.30 [.078-.130]	Blue/Green	6.35-7.13 [.250-.281]	—	—
12-10	Multiple■	Natural/Yellow	7.93-8.71 [.312-.343]	8.71-9.53 [.343-.375]	—
		Yellow			8.74-9.53 [.344-.375]
12	2.41-5.08 [.095-.200]	Yellow/Yellow	9.53-10.31 [.375-.406]	—	—
10	3.02-5.08 [.119-.200]	Yellow/Brown	9.53-10.31 [.375-.406]	—	—

■ Contact PRODUCT INFORMATION at the number on page 1 for acceptable insulation diameter ranges

† Large sleeve terminal designed for Class I E Nuclear applications

● For use with heavy-duty terminals having an insulation thickness of 1.02-1.27 [.040-.050]

Figure 2

### 3.4. Wire Placement

The stripped wire must be inserted into the wire barrel until the wire insulation is against the wire barrel but not inside it. The wire insulation must be inside the metal sleeve. A gap between the wire insulation and wire barrel is allowed, but not to exceed the dimension given in Figure 3.

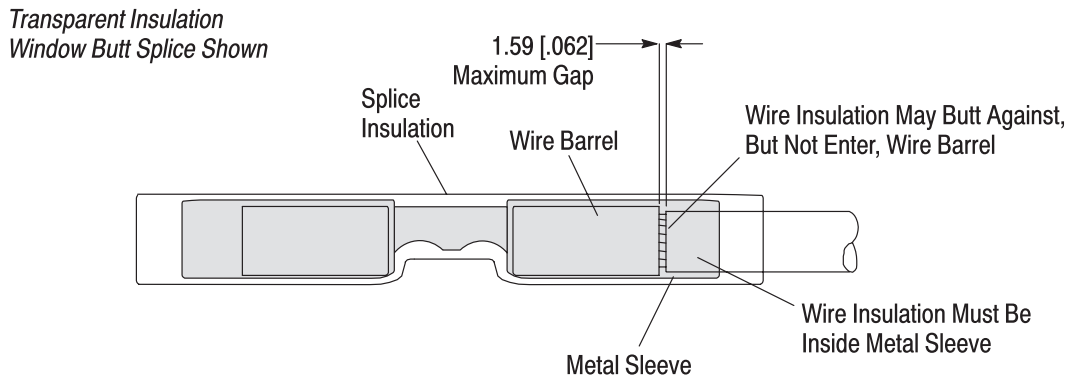

Figure 3

### 3.5. Crimp Requirements

#### A. Crimp Height

The spring-back of the terminal, splice, or end cap insulation prevents an accurate direct measurement of crimp height. However, crimping a slug of solder (60% tin and 40% lead) with a diameter slightly larger than the conductor outside diameter can verify proper termination. The crimp height of the resulting solder slug can be checked with a standard micrometer or comparator. The measurement must be made over the most compressed area of the solder slug. See Figure 4.

**NOTE**

Some tooling with multiple crimping chambers form an embossed dot code in the terminal, splice, or end cap insulation that indicates which crimping chamber was used. This dot code can be used as a visual inspection to ensure that the correct wire size and crimping chamber were used.

#### Crimp Inspection Using Micrometer or Comparator

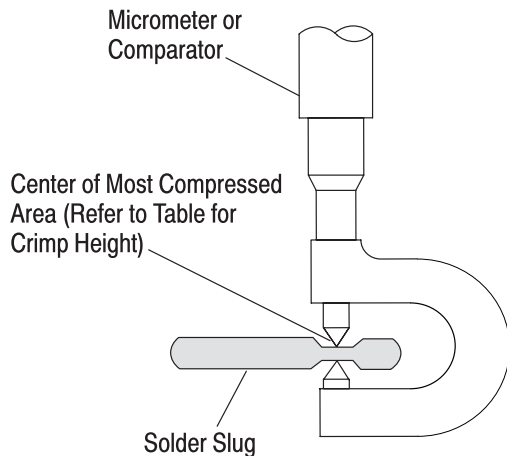

#### Wire Barrel Crimp Profile and Location

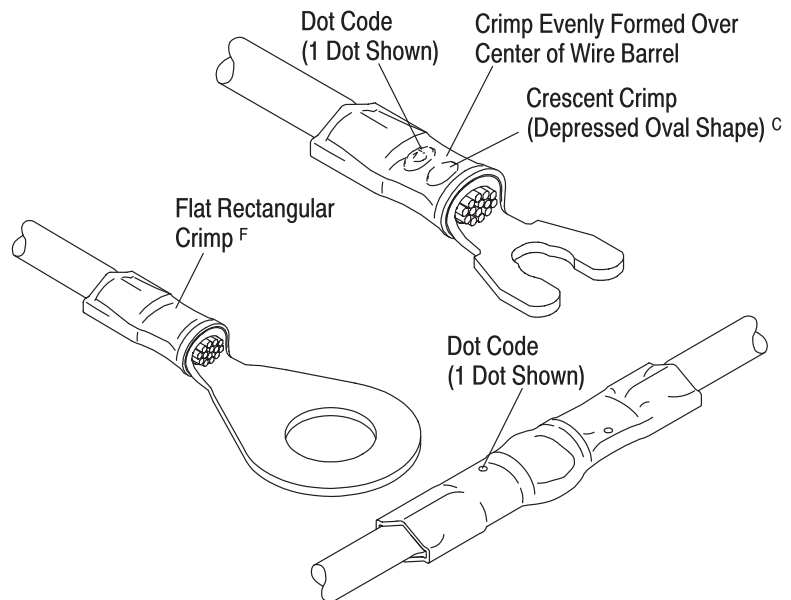

C Produced by Crescent Crimp Tooling  
 F Produced by TETRA-CRIMP Tooling

Figure 4 (Cont'd)

WIRE SIZE (AWG)	TERMINAL, SPLICE, OR END CAP INSULATION COLOR	DOT CODE	SOLDER SLUG		
			DIAMETER	CRIMP HEIGHT	
				CRESCENT CRIMP (Depressed Oval Shape)	FLAT RECTANGULAR CRIMP
26	Yellow/Black	1 Dot	3.18 [.125]	1.60-1.75 [.063-.069]	—
26-24	Yellow				
26-22	Yellow				
24	Yellow/Blue				
24-20	White	2 Dots	3.18 [.125]	2.26-2.41 [.089-.095]	—
	Natural/White				
22	Red/Green	1 Dot	3.18 [.125]	2.77-2.92 [.109-.115]	1.98-2.18 [.078-.086]
22-16	Red	1 Dot			
	Natural/Red				
20	Red/Red	1 Dot			
18	Red/White	1 Dot	3.18 [.125]	3.02-3.18 [.119-.125]	2.34-2.54 [.092-.100]
16	Blue/Blue	2 Dots			
16-14	Blue	2 Dots	4.76 [.187]	3.02-3.18 [.119-.125]	2.34-2.54 [.092-.100]
	Natural/Blue				
14	Blue/Green	2 Dots			
16-14●	Yellow/Black	1 Dot			
12	Yellow/Yellow	1 Dot			
12-10	Yellow	1 Dot			
	Natural/Yellow				
10	Yellow/Brown	1 Dot			

● For use with heavy duty terminals having an insulation thickness range of 1.02-1.27 [.040-.050].

Figure 4 (End)

**B. Wire Barrel Crimp Profile and Location**

The wire barrel crimp produced by the tooling (dies, heads, hand tools, pneumatic tools, or machines) must be either a confined crescent crimp which appears as a depressed oval shape or a flat rectangular crimp over the center of the wire barrel. The crimp must be evenly formed. Refer to Figures 4, 5, and 11.

Crescent crimp tooling produces the crescent crimp, and TETRA-CRIMP tooling produces the flat rectangular crimp. For a tooling-to-crimp profile cross-reference, refer to Figure 10.

**C. Dot Code**

The dot code on the insulation must be well formed and correspond with the wire size or color code marking on the crimping chamber of the tooling used. See Figures 4 and 5.

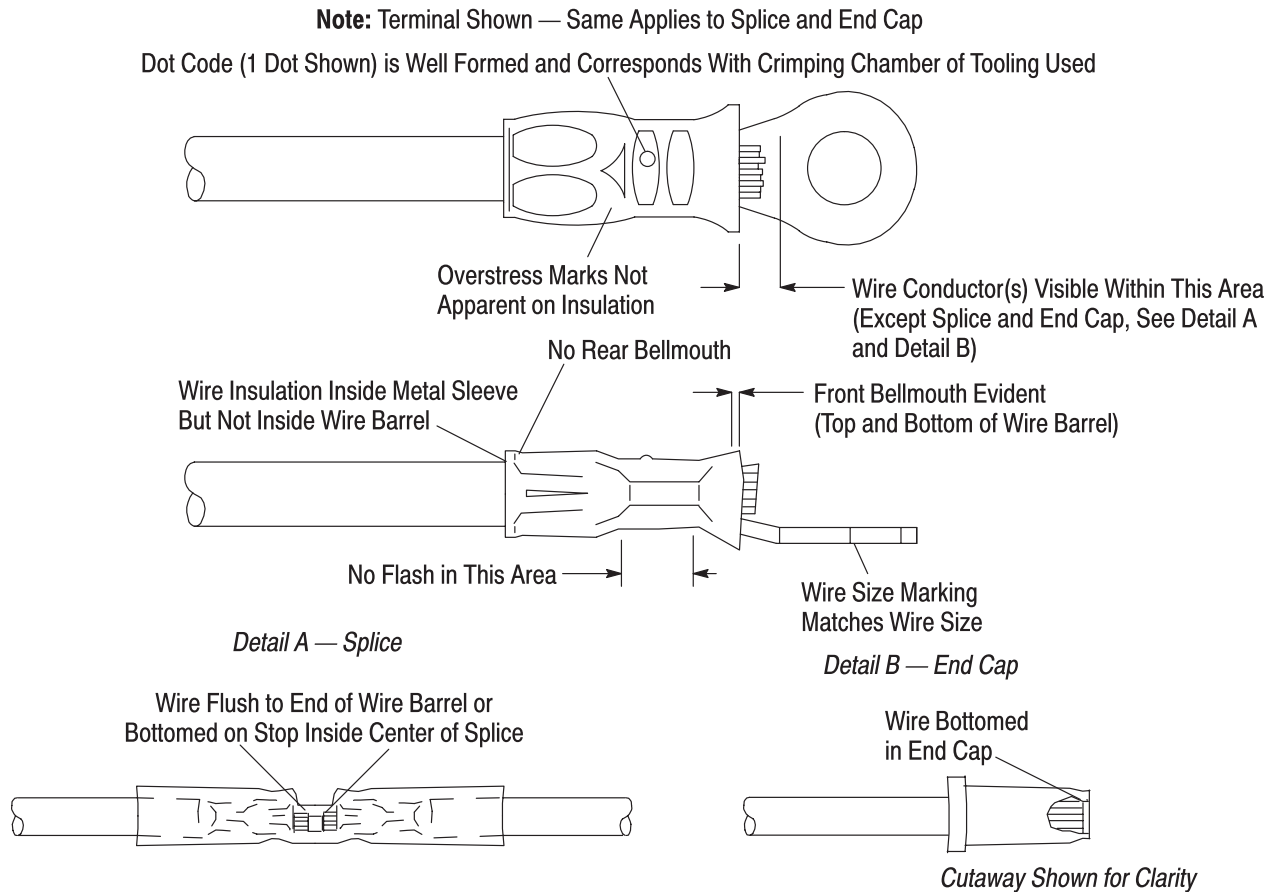

Figure 5

#### D. Insulation Crimp

The insulation crimp must capture the wire insulation. The wire insulation must not be crimped inside the wire barrel of the terminal, splice, or end cap. The wire insulation must be inside the metal sleeve to provide strain relief for the wire. See Figure 5.

#### E. Bellmouths

There shall be no rear bellmouth. The front bellmouth shall be evident on the top and bottom of the wire barrel as shown in Figure 5. Also see Figure 11.

#### F. Flash

There shall be no flash or extruded insulation material visible in the most compressed area of the wire crimp. See Figure 5.

#### G. Terminal, Splice, or End Cap Insulation

The insulation of the terminal, splice, or end cap must not be cut or show uneven stress marks or highlighted marks on the insulation. See Figure 5.

#### H. Wire Location

1. Terminals shall have the wire ends flush or extended slightly beyond the end of the wire barrel as shown in Figure 5.
2. Splices shall have the end of the wire located against the wire stop inside the center of the splice.
3. End caps shall have the end of the wire bottomed in the end cap.

#### I. Insulation Crimp Check

The hold of the insulation crimp can be tested by using the bend test which, if successful, indicates that the hold is not too loose. The bend test must be performed as follows:



1. Using an *unstripped* wire, make a test crimp.
2. Hold the terminal, splice, or end cap in one hand. Use the side of one finger on the other hand at approximately 76 [3] to push the wire up 90° and down 180°, one time each. Refer to Figure 6.

If the wire insulation comes out during the bend test, the insulation crimp is not tight enough, and the tooling must be adjusted to produce a tighter insulation crimp. Figure 8, Detail A shows a crimp that is too loose, providing little or no support for the wire.

If the crimp passes the bend test, the insulation crimp must be tested by pulling the wire from the terminal, splice, or end cap. If the wire insulation is only slightly deformed, the crimp is correct. Figure 8, Detail B shows a desired crimp, providing adequate support without damage to either the insulation or the wire conductor(s). If there is visible damage, such as tearing or piercing of the insulation, the crimp is too tight, and the tooling must be adjusted to produce a looser insulation crimp. Figure 8, Detail C shows a crimp that is too tight, damaging the insulation and possibly breaking wire conductor(s) or reducing circular mil area (CMA) by wire extrusion.

**Note:** Not to Scale

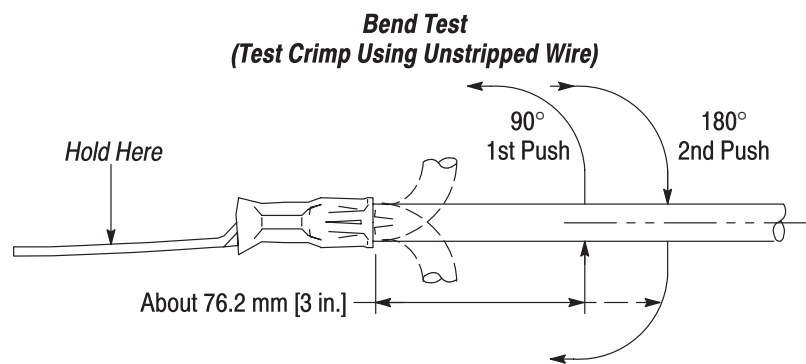

Figure 6

### 3.6. Tensile Strength

Crimped terminals, splices, or end caps should hold the wire conductor(s) firmly and have a pull-test tensile value meeting that specified in the table in Figure 7.

**NOTE**

Adjust tensile testing machine for head travel of 25.4 [1.0] per minute. Directly and gradually apply force for 1 minute.

WIRE SIZE (AWG)	TENSILE FORCE (Pull Test) Newtons [lb-force]	
	COMMERCIAL REQUIREMENTS	MILITARY REQUIREMENTS
26	13.4 [3]	31.1 [7]
24	22.3 [5]	44.5 [10]
22	35.6 [8]	66.7 [15]
20	57.9 [13]	84.5 [19]
18	89.0 [20]	169.0 [38]
16	133.5 [30]	222.5 [50]
14	222.5 [50]	311.5 [70]
12	311.5 [70]	489.3 [110]
10	356.0 [80]	667.2 [150]

Figure 7



**Cross-Section of Insulation Crimp At Wire End of Terminals, Splice, or End Cap**  
 (Sketches represent the uppermost wire insulation range of the Terminals, Splice, or End Cap. Thinner wire insulation may appear slightly different, but will perform the same.) Refer to Figure 2.

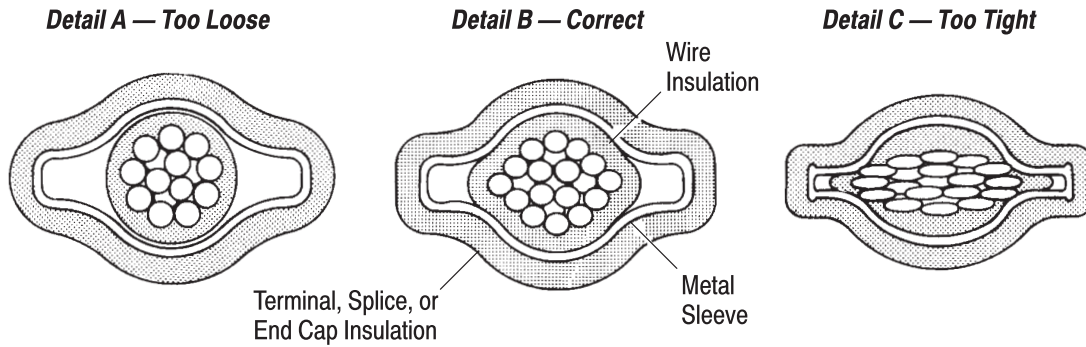

Figure 8

### 3.7. Bend Allowance

Upward and downward bend of the terminated terminal, splice, or end cap must be within the tolerance provided in Figure 9.

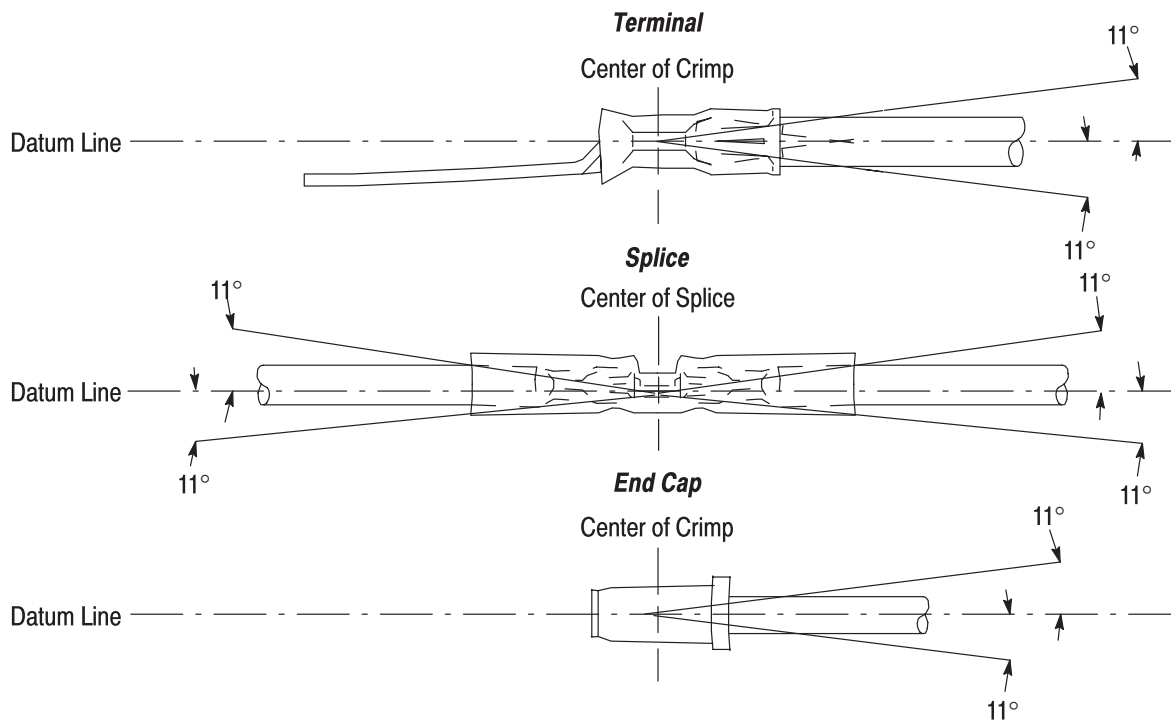

Figure 9

### 3.8. Repair

Damaged or defective terminal, splice, or end cap must not be used. If damage is evident, the terminal, splice, or end cap should be cut from the wire and replaced with a new one. Crimped terminals, splices, or end caps **MUST NOT** be re-terminated or re-used by removing the wire.

## 4. QUALIFICATIONS

Most, but not all, PIDG terminals, splices, and end caps meet the requirements of the following agencies:

**NOTE**

*To ascertain whether a terminal, splice, or end cap (identified by part number) meets the requirements of the following agencies, contact PRODUCT INFORMATION at the number at the bottom of page 1.*

- Military Specification (MS) 25036 and M7928/1, /4, /5, and /6 (Class I and Class II)
- Listed by Underwriters Laboratories Inc. (UL) under File E13288 and Certified by CSA International under File LR7189

## 5. TOOLING

Hand tools for manual application of loose piece terminals, splices, or end caps, and automatic and semi-automatic machines for power assisted application of tape-mounted terminals, splices, or end caps are available to cover the full wire size range. Tooling part numbers and instructional material packaged with the tooling are shown in Figure 10.

**NOTE**

*Selection of tooling will depend on the terminal, splice, or end cap requirements such as quantity of terminations, operator training and skill, and the available support equipment (electrical, pneumatic, etc.) in the work area. Modified designs and additional tooling concepts may be available to meet other production requirements. For additional information, contact one of the service groups at the bottom of page 1.*

### 5.1. Hand Tools

Hand tools consisting of a handle assembly with integral fixed jaws or dies and hand tools that accept various die assemblies are available for loose piece terminals, splices, or end caps. Both types feature a ratchet to ensure full crimping pressure is applied to the terminal, splice, or end cap.

### 5.2. Die Assemblies

Die assemblies are precision tools that form the wire barrel of the terminal, splice, or end cap onto the conductor(s) of the wire and form the optimum crimp height. The die assemblies consist of stationary and movable dies that are designed for a specific wire size and terminal, splice, or end cap.

#### A. Loose Piece Terminal, Splice, or End Cap

These die assemblies can be used in either manual or power assist tools.

#### B. Tape-Mounted Terminal, Splice, or End Cap

These die assemblies are designed for use in applicators installed in power units.

### 5.3. Applicators

Applicators are used in power units for large production applications. They feature an automatic feed mechanism, adjustable crimp height pads, and precision crimping dies. They have been designed to simplify tooling changes and avoid unnecessary duplication of power units.

### 5.4. 626 Pneumatic Tooling System

This pneumatically operated tooling system will crimp the full wire size range of the terminal, splice, or end cap. The system is a pneumatic power unit available with a logic control for foot pedal operation or without foot pedal for hand operation. It is designed to accept various types of crimping heads, including those that will accept die assemblies for loose piece terminals, splices, or end caps.

### 5.5. Power Units

Power units provide the force needed to operate the applicator.

#### A. Bench-Mounted

AMP-O-ELECTRIC Model "G" terminating machine, AMP-TAPETRONIC machine, and AUTO-PRO terminating machine are designed to accept hand-fed pre-stripped wires.

#### B. Floor Standing

The AMPOMATOR CLS IV+ lead-making machine can be set up to automatically cut the wire to length and terminate it at a high rate of speed.

**Loose Piece Terminal, Splice, or End Cap**

Hand Tools and Die Assemblies  
(Refer to Table for Part Numbers)

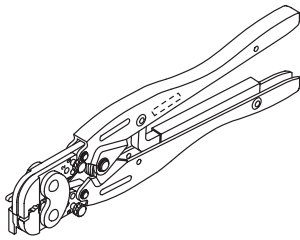

Double Action Hand Tools (DAHT) (408-1559)

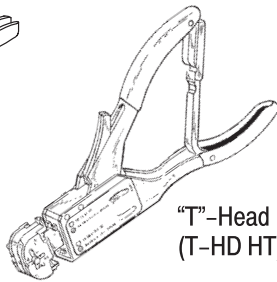

"T"-Head Hand Tools (T-HD HT) (408-1610)

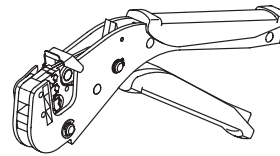

TETRA-CRIMP Hand Crimping Tool (408-2823)

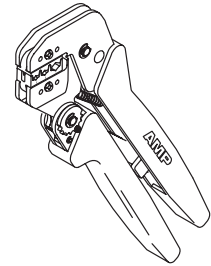

PRO-CRIMPER Hand Crimping Tool (408-9252)

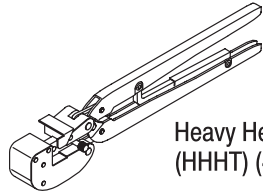

Heavy Head Hand Tools (HHHT) (408-1261)

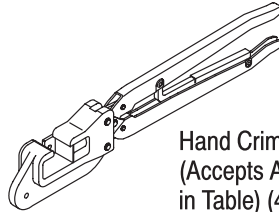

Hand Crimping Tool 69710-1 (Accepts All Die Assemblies in Table) (408-2095)

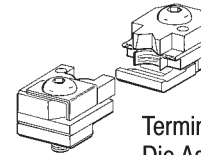

Terminal and Splice Die Assemblies (408-1632)

**626 Pneumatic Tooling System**

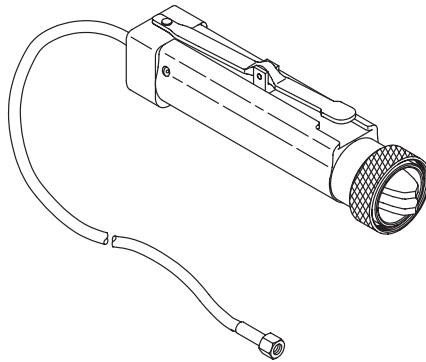

626 Pneumatic Tooling Assemblies 189721-[] (409-5862)

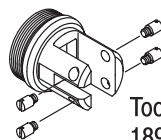

Tool Holder Assembly 189928-1 (Straight Action)

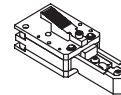

Straight Action Crimper 217200-[] (Accepts All Die Assemblies in Table) (408-4105)

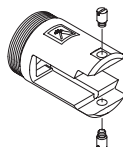

Tool Holder Assembly 189767-[] (Large)

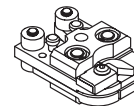

Pneumatic Crimping Heads (Refer to Table) (408-9586)

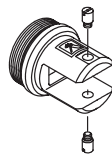

Tool Holder Assembly 189766-[] (Small)

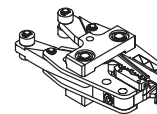

TETRA-CRIMP Pneumatic Adapter (Refer to Table) (408-4099)

WIRE SIZE (AWG)	HAND TOOL					PNEUMATIC TOOLING		DIE ASSEMBLY <sup>□C</sup>
	DAHT <sup>C</sup>	T-HD HT <sup>C</sup>	TETRA-CRIMP Hand Tool <sup>F</sup>	PRO-CRIMPER Hand Tool <sup>C</sup>	HHHT <sup>C</sup>	Crimping Head <sup>C</sup>	TETRA-CRIMP Adapter <sup>F</sup>	
26-22	46121	59275	—	—	—	314537-1	—	69344
22-18	—	59250	—	—	—	—	—	—
22-16	47386	59250	59824-1	58433-3	—	314270-3	—	47806-2
16-14■	47387	59250	59824-1	58433-3	—	314269-1	—	47807-1
16-14● and 12-10	—	—	59824-1	58433-3	59239-4 or 59287-2◇	—	679305-1●	47808-6 or 47808-5◇

■ For use with terminals having an insulation thickness range of 0.51–0.84 [.020–.033].  
 ● For use with heavy duty terminals having an insulation thickness of 1.02–1.27 [.040 –.050].  
 ◇ For use with wire having a maximum insulation diameter of 7.62 [.300].

<sup>C</sup> Produces Crescent Crimp  
<sup>F</sup> Produces Flat Rectangular Crimp  
<sup>□</sup> For use with Tool 69710-1 or Crimper 217200-[]

Figure 10 (Cont'd)

**Tape-Mounted Terminal, Splice, or End Cap**

*Die Assemblies and Applicators*

*Power Units*

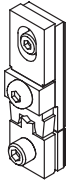

Die Assemblies 69872, 69873, 69874, 69877, and 69897 (408-2423)

Die Assemblies 59826-1, 59827-1, and 59828-1 (408-2822)

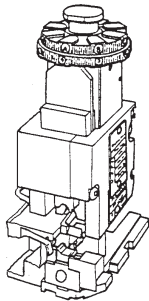

Miniature Quick-Change Applicator 567200-3 (408-8082)

Miniature Quick-Change Applicator 687658-1 (408-8044)

Applicator 818057-2 (408-8088)

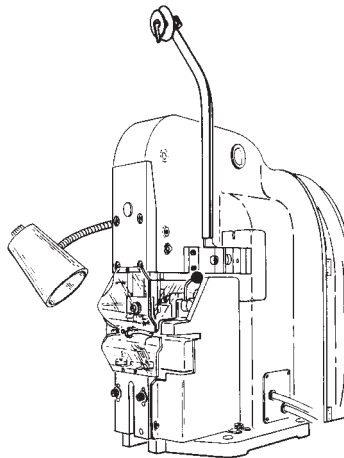

**AMP-TAPETRONIC Machine**  
69875(409-1993)

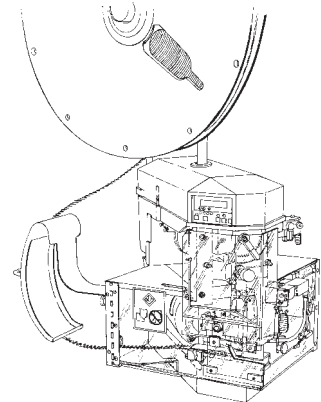

**AMP-O-LECTRIC Model "G" Terminating Machine** 354500-1 (409-5842)

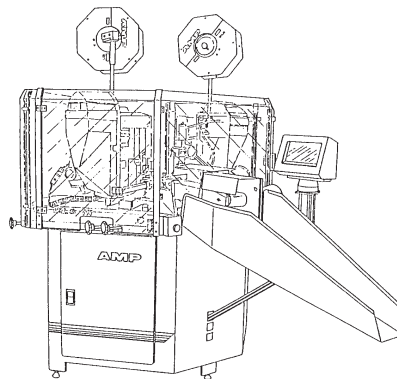

**AMPOMATOR CLS IV+ Lead-Making Machine** 356500-[] (409-5878)

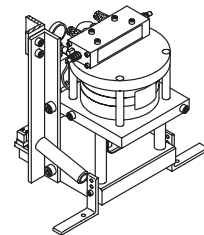

**AUTO-PRO Terminating Machine** 818380-1 (408-9491)  
No Longer Manufactured New

WIRE SIZE (AWG)	DIE ASSEMBLY	APPLICATOR			
		AMP-TAPETRONIC Machine	AMP-O-LECTRIC Model "G" Terminating Machine	AMPOMATOR CLS IV+ Lead-Making Machine	AUTO-PRO Terminating Machine
26-22	69877 <sup>C</sup>	Included with Machine	567200-3	687658-1	818057-2
22-16	69872 <sup>C</sup> or 59826-1 <sup>F</sup>				
16-14■	69873 <sup>C</sup> or 59827-1 <sup>F</sup>				
16-14● and 12-10	69874◇ <sup>C</sup> or 59828-1◇ <sup>F</sup> or 69897 <sup>C</sup>				

- For use with terminals having an insulation thickness range of 0.51–0.84 [.020–.033].
- For use with heavy duty terminals having an insulation thickness of 1.02–1.27 [.040 –.050].
- ◇ For use with wire having a maximum insulation diameter of 7.62 [.300].

- <sup>C</sup> Produces Crescent Crimp
- <sup>F</sup> Produces Flat Rectangular Crimp

Figure 10 (End)

**6. VISUAL AID**

Figure 11 shows a typical application of PIDG terminals, splices, and end caps. This illustration should be used by production personnel to ensure a correctly applied terminal, splice, or end cap. Applications which DO NOT appear correct should be inspected using the information in the preceding pages of this specification and in the instructional material shipped with the product or tooling.

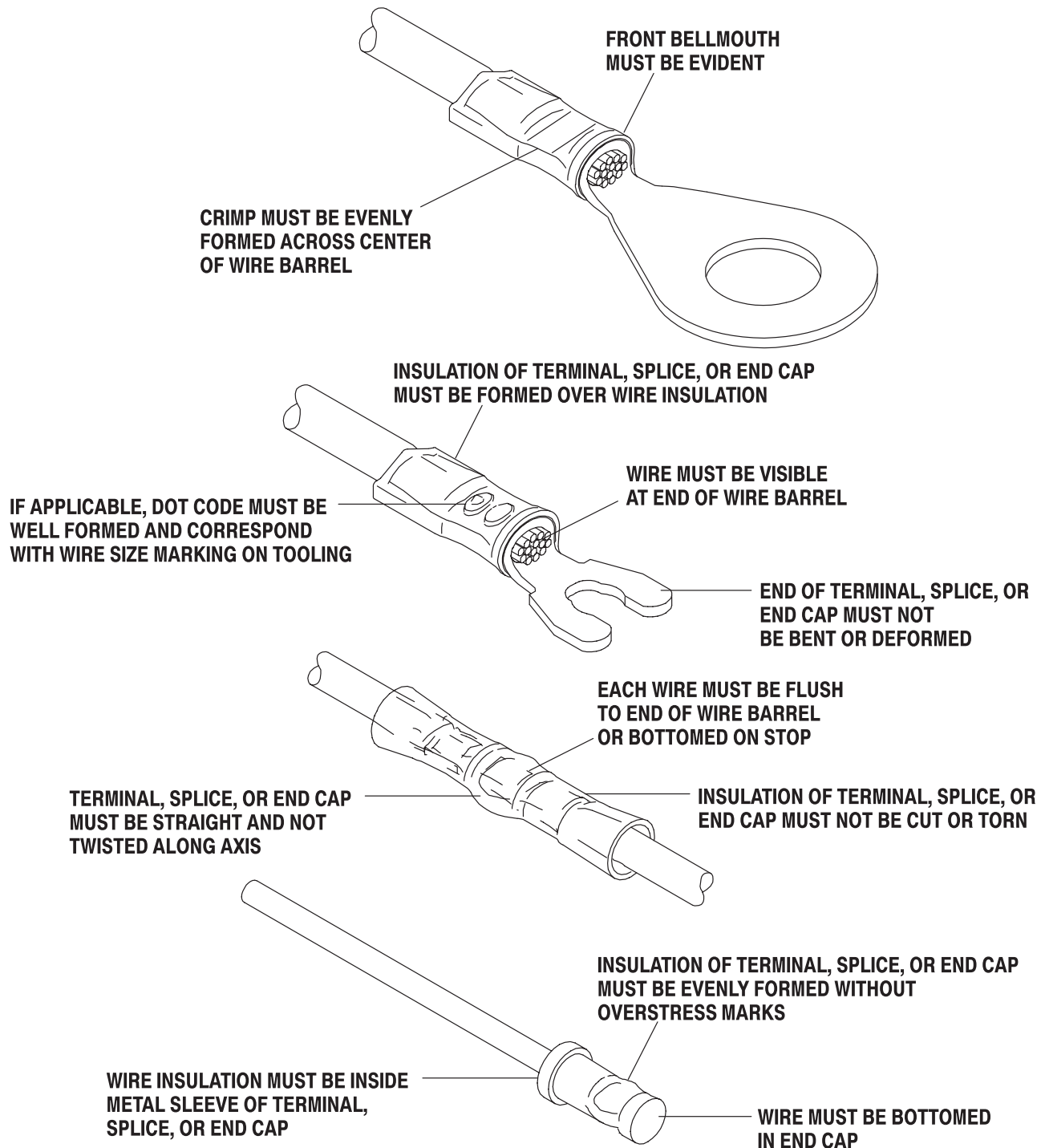

**FIGURE 11. VISUAL AID (CONT'D)**

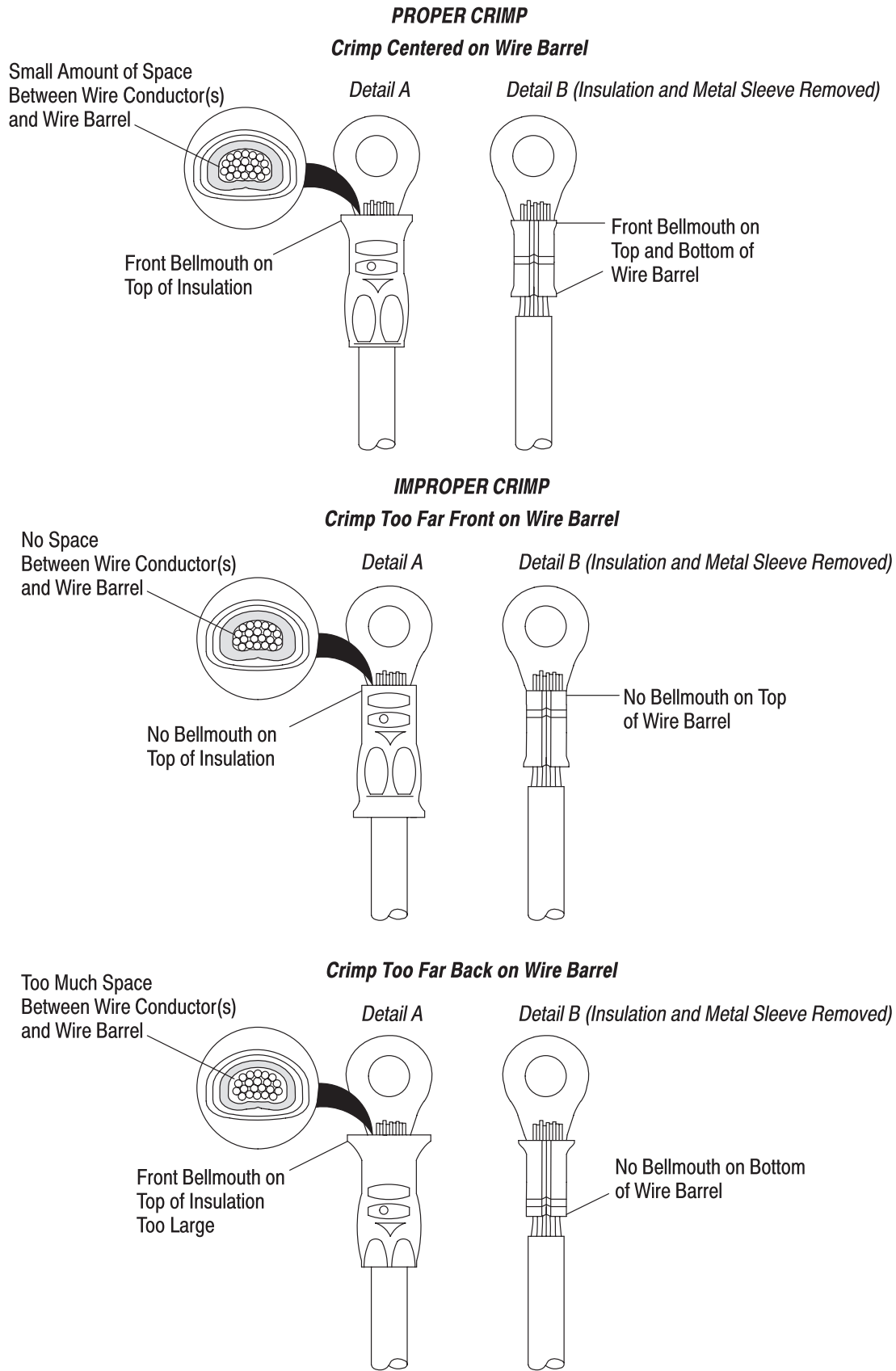

**FIGURE 11. VISUAL AID (END)**