

TYPE 258



FEATURES:

- Contact rating up to 15A@240V resistive load.
- UL/CSA/TUV approved.
- AC & DC coils available.
- PCB terminal and socket type.



CONTACT RATING

Resistive Load	UL	CSA	TUV
	15A/28VDC	15A/28VDC	15A/250VAC, 15A/30VDC
Motor	1/2HP, 120VAC	1/2 HP, 120VAC	6.2A/120VAC, Cos ϕ 0.5
Gen. use	15A/240VAC	10A/240VAC, 15A/120VAC	

COIL DATA (DC)

Rated Voltage (VDC)	Rated Current $\pm 10\%$ at 25°C (mA)	Coil Resistance $\pm 10\%$ at 25°C (Ω)	Max. Continuous Voltage at 25°C	Pickup Voltage (Max) at 25°C	Dropout Voltage (Min) at 25°C	Power Consumption at Rated Voltage
6	150	40	110% of rated voltage	75% of rated voltage	10% of rated voltage	Approx. 0.9 W
12	75	160				
24	37	650				
48	19	2600				
110	10	11000				

COIL DATA (AC)

Rated Voltage (VAC)	Coil Resistance $\pm 10\%$ at 25°C (Ω)	Max. Continuous Voltage at 25°C	Pickup Voltage (Max) at 25°C	Dropout Voltage (Min) at 25°C	Power Consumption at Rated Voltage
12	40	110% of rated voltage	85% of rated voltage	30% of rated voltage	approx. 1.2 VA
24	160				
120	3400				
240	13600				

PART NUMBERING SYSTEM

Relay Type	Enclosure & Terminals	Contact Form	Coil Voltage	Contact Material & Ratings	Standard or Special
258	1–Dust Cover/Solder Lug 2–Dust Cover PCB 6–Flanged Cover/Solder Lug	1–SPDT 4–SPST, NO 5–SPST, NC 2–DPDT 6–DPST, NO (For Enclosures 1&6)	A–6VDC B–12VDC C–24VDC D–48VDC F–110VDC P–12VAC Q–24VAC T–120VAC U–240VAC	2–Standard, Ag Cd0	00–Standard C0–Standard LC–Lamp & Push Button L0–Lamp Across Coil (For Enclosure 1 only & for DPDT only) A1-Z9–Special

Example: 258-11A200

Stock Item: 258-12B200, 258-12C200, 258-12T200, 258-12Q200, 258-22B200, 258-22C200, 258-22T200, 258-22Q200, 258-62B200, 258-62C200, 258-62T200, 258-62Q200.

TYPE 258

SPECIFICATIONS

Contact resistance	30 m Max. (initial value)
Operate time	25 mS Max.
Release time	25 mS Max.
Insulation resistance	100 M Min. (DC 500V)
Dielectric strength @25°C	Between open contact: AC 500 V 50/60 Hz 1 minute.
	Between contact and coil: AC 1500 V 50/60 Hz 1 minute.
	Between live parts & ground: AC 1500 V 50/60 Hz 1 minute.
Vibration resistance	Damage limits & Operating extremes: 10~55 Hz, amplitude 1.0 mm
Shock resistance	Damage limits: 100g, Operating extremes: 20g
Life expectancy for mechanical	10,000,000 operations (frequency 18,000 operations/hr)
Life expectancy for electrical	100,000 operations (frequency 1,800 operations/hr)
Operating temperature	-25~+55°C (no freezing)
Weight	Approx. 32g

DIMENSIONS

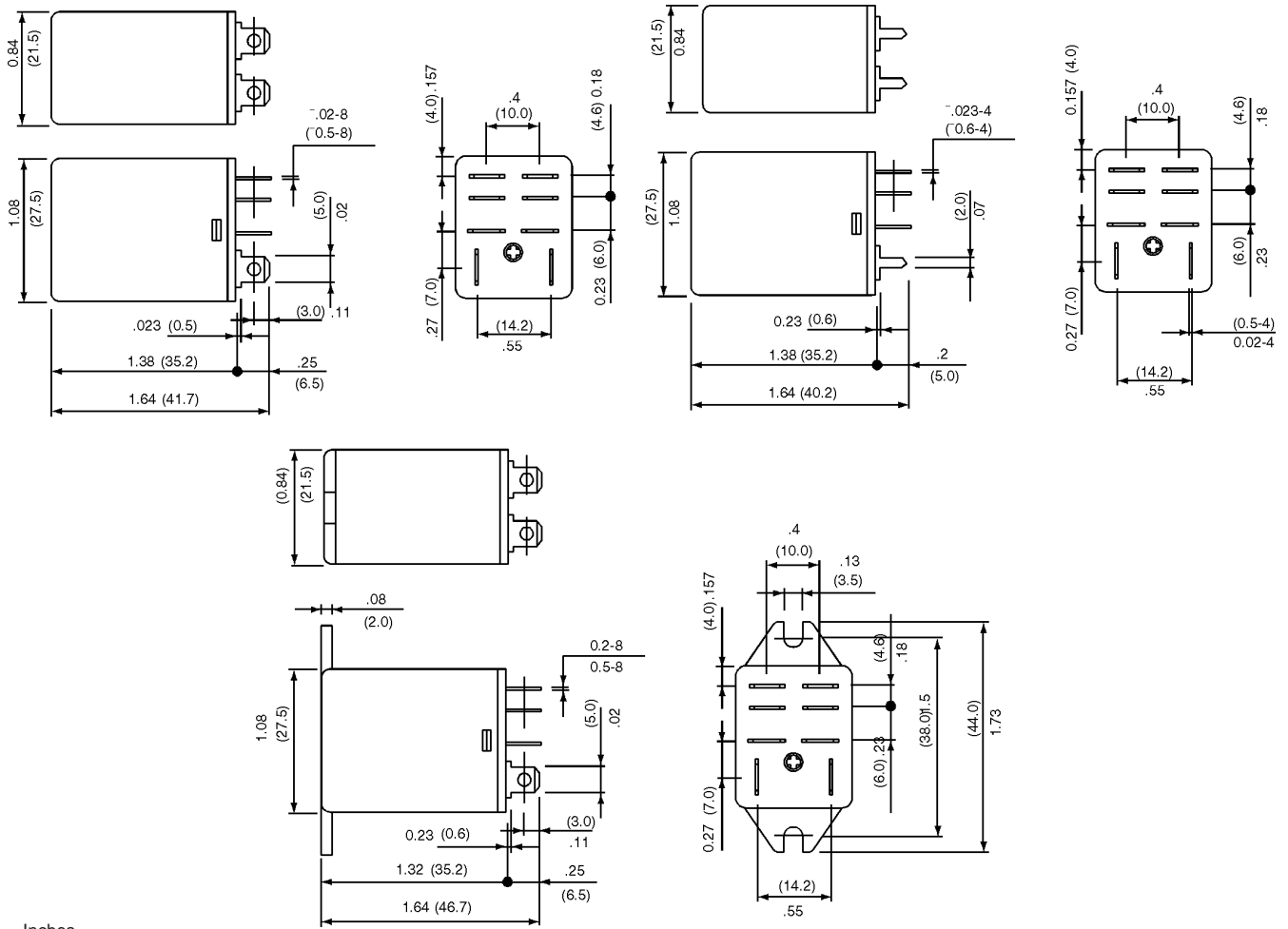

Inches
(Millimeters)

WIRING

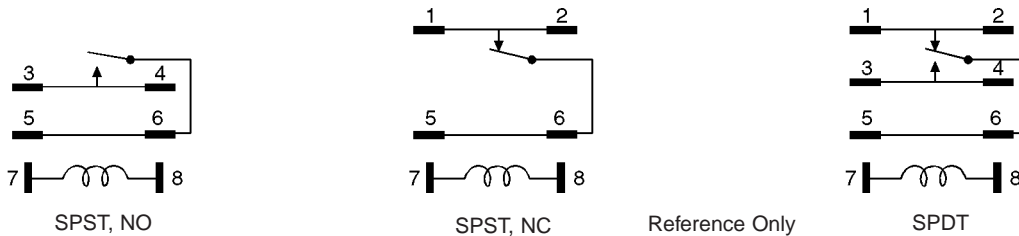

TYPE 258

PCB LAYOUT

Inches
(Millimeters)

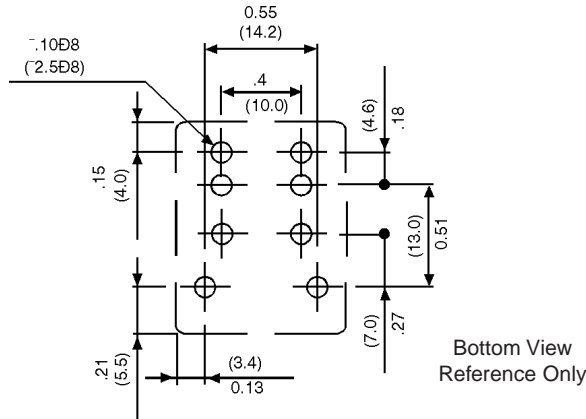

CURVES

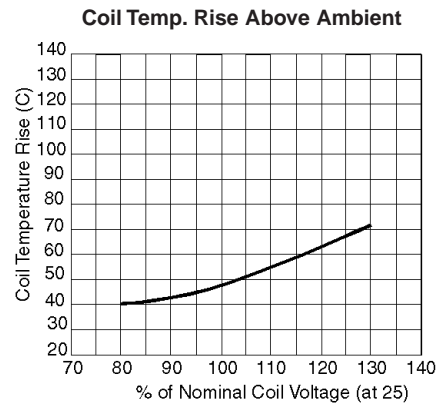
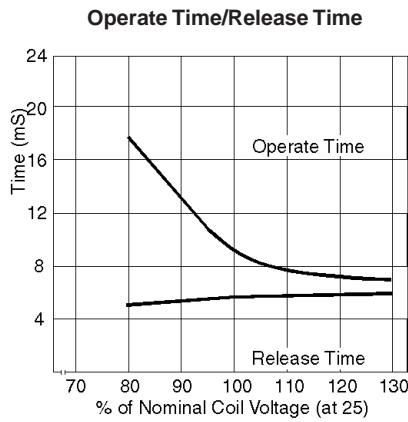
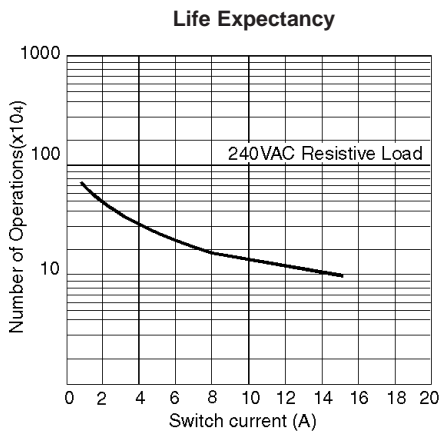

SAFETY APPROVAL

CERTIFIED	FILE NO.
UL	E38802
CSA	LR700557
TUV	9452081