

Interface Plug-in Relay XT

- 1 pole 16 A, 2 pole 8 A, 1 CO contact or 2 CO contacts
- DC- or AC coil, sensitive coil 400 mW
- Reinforced insulation, protection class II (VDE 0700)
- 4 kV / 8 mm coil-contact
- Manual test tab, optionally lockable¹⁾
- Version with mechanical and/or electrical indicator optionally available
- Suitable for use in Tyco standard RT sockets
- Recycleable packaging



F0289-B

Applications

Panel boards, mechanical engineering

Approvals

VDE REG.-Nr. B758, cULus E214025
 Technical data of approved types on request

Contact data	1-pole	2-pole
Contact configuration	1 CO	2 CO
Contact set	single contact	
Type of interruption	micro disconnection	
Rated voltage / max. switching voltage AC	240 / 400 VAC	
Rated current	16 A	8 A
Limiting continuous current	16 A	8 A, UL: 10 A
Maximum breaking capacity AC	4000 VA	2000 VA
Limiting making capacity,max 4 s, df 10%	30 A	15 A
Contact material	AgNi 90/10	
Rated frequency of operation with / without load	6 / 600 min ⁻¹	
Operate- / release time DC coil	max 8 / 6 ms	max 10 / 5 ms
Bounce time DC coil, NO / NC contact	max 4 / 6 ms	max 4 / 9 ms

Contact ratings

Type	ContactLoad	Ambient temp. [°C]	Cycles
IEC 61810			
XT3	CO 16 A, 250 VAC, cosφ=1	70°C	30x10 ³
XT3	NO 16 A, 250 VAC, cosφ=1	70°C	50x10 ³
XT4	CO 8 A, 250 VAC, cosφ=1	70°C	50x10 ³
XT4 DC-coil	NO 8 A, 250 VAC, cosφ=1	70°C	100x10 ³
UL 508			
XT3	CO 16 A, 250 VAC, general purpose	70°C	30x10 ³
XT4	CO 10 A, 250 VAC, general purpose	70°C	20x10 ³
XT4	CO 8 A, 250 VAC, general purpose	70°C	30x10 ³

Coil data

Rated coil voltage range DC coil	6...110 VDC
AC coil	24...230 VAC
Operative range to IEC 61810	2
Coil insulation system according UL1446	class F

¹⁾ Locking function description

If the test button is pulled out too forcefully, it may bypass the momentary testing position and go straight into the locked position.
 Delivery status is with testing possibility only, to reach locking position please remove the locking plastic pip according drawing.

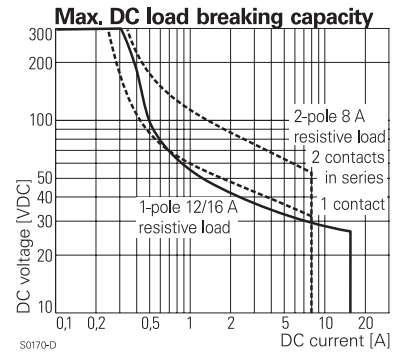

S0170-D

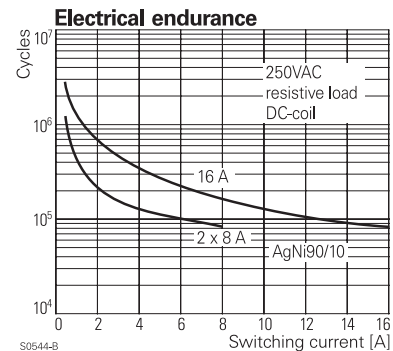

S0544-B

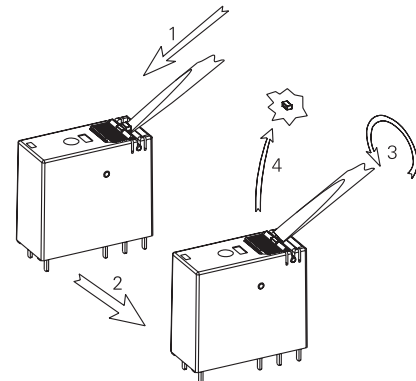

Interface Plug-in Relay XT (Continued)

Coil versions, DC-coil

Coil code	LED & PD*	Rated voltage VDC	Operate voltage VDC	Release voltage VDC	Coil resistance Ohm	Rated coil power mW	opt. LED power mW
012	LB2	12	8.4	1.2	360±10%	400	10
024	LC4	24	16.8	2.4	1440±10%	400	19
048	LE8	48	33.6	4.8	5520±10%	417	39
110	MBO	110	77.0	11.0	28800±12%	420	87

All figures are given for coil without preenergization, at ambient temperature +23°C

*) Protection diode PD; standard polarity: +A1 / -A2

Other coil voltages on request

Coil versions, AC-coil

Coil code	LED	Rated voltage VAC	Operate voltage VAC	Release voltage VAC	Coil resistance Ohm	Rated coil power VA	opt. LED power VA
524	R24	24	18.0 / 19.2	3.6	350±10%	0.76 / 0.58	0.012
615	S15	115	86.3 / 92.0	17.3	8100±15%	0.76 / 0.58	0.054
730	T30	230	172.5 / 184.0	34.5	32500±15%	0.74 / 0.58	0.073

All figures are given for coil without preenergization, at ambient temperature +23°C

Other coil voltages on request

Insulation

Dielectric strength coil-contact circuit	5000 V _{rms} in combination with RT78726	
	4000 V _{rms} in combination with RT78725	
open contact circuit	1000 V _{rms}	
adjacent contact circuits	2500 V _{rms}	
Clearance / creepage coil-contact circuit	≥ 8 / 8 mm	
Material group of insulation parts	IIIa	
Tracking index of relay base	PTI 175 V	
Insulation to IEC 60664-1		
Type of insulation coil-contact circuit	reinforced	
open contact circuit	micro disconnection	
adjacent contact circuits	basic	
Rated insulation voltage	250 V	
Pollution degree	3	2
Rated voltage system	240 V	230 / 400 V
Overvoltage category	III	

Other data

	1-pole	2-pole
Mechanical endurance DC coil	> 10 x 10 ⁶	
AC coil	> 5 x 10 ⁶	
Material	RoHS - Directive 2002/95/EC compliant	
Environment		
Ambient temperature range DC coil	-40...+70°C	
AC coil	-40...+70°C	
Vibration resistance (function), NO / NC cont.	20 / 5 g, 30 ... 500 Hz	
Shock resistance (destruction)	100 g	
Category of protection	RTII	
Processing		
Mounting distance	≥ 4,5 mm, dense packing of sockets	
Relay weight	16 g	
Packaging unit	10 / 250 pcs	

Accessories

For Details see datasheet Accessories Interface Power Relay XT

NOTE: indicated contact ratings and electrical endurance data for direct wiring of relays (according IEC 61810-1, table 12); for relays mounted on sockets deratings may apply.

Coil operating range DC

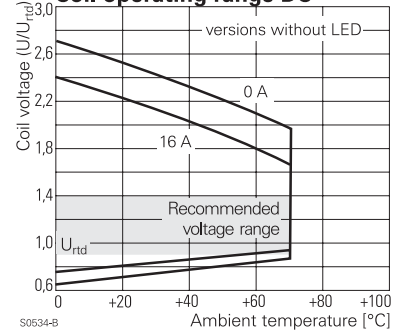

Coil operating range AC

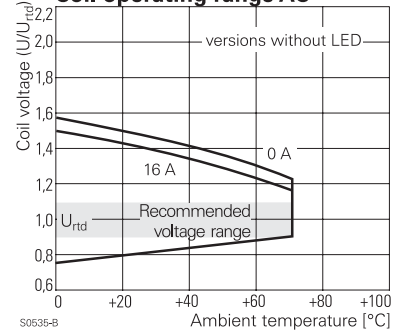

Terminal assignment

Bottom view on pins

1 CO contact 16 A

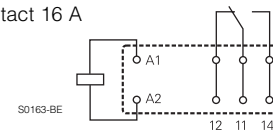

2 CO contacts 8 A

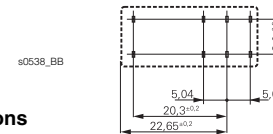
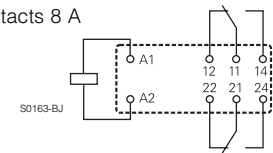

Dimensions

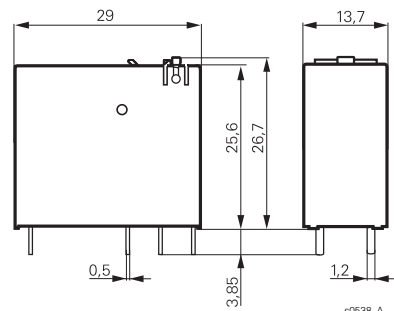

Interface Plug-in Relay XT (Continued)

Product key	Typical product key	XT	3	7	4	T30
Type	XT Interface Plug-in Relay XT					
Version	3 1-pole, 16 A, pinning 5 mm 4 2-pole, 8 A, pinning 5 mm					
Contact configuration	1 1 CO contact (1 form C) 7 1 CO contact (1 form C) with test button and mechanical indicator 2 2 CO contacts (2 form C) 8 2 CO contacts (2 form C)with test button and mechanical indicator					
Contact material	4 AgNi 90/10					
Coil	Coil code: please refer to coil versions table, preferred types in bold print					

Product key	Contacts	Cont. material	Coil	Coil	Part number
XT374LC4	1 CO contact	AgNi 90/10	DC-coil	24 VDC	1887112-1
XT374R24	16 A	test button,	AC-coil	24 VAC	1887113-3
XT374T30		mechanical		230 VAC	1887113-1
XT484LC4	2 CO contacts	and electrical	DC-coil	24 VDC	1887212-1
XT484R24	8 A	indicator	AC-coil	24 VAC	1887213-3
XT484T30				230 VAC	1887213-1