

- NOTES:
- 1: FOR MATERIAL SPECIFICATION SEE NOTE 1. ON SHEET 2.
 - 2: FOR RECOMMENDED P.C.B.HOLE PATTERN, PART No's AND UNSTATED DIMENSIONS SEE SHEET 2.
 - 3: PRODUCT SPEC. No. :PS 99020-0015

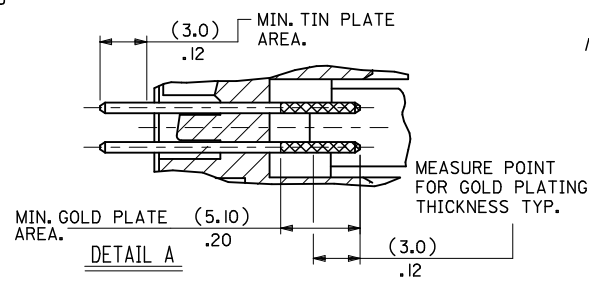
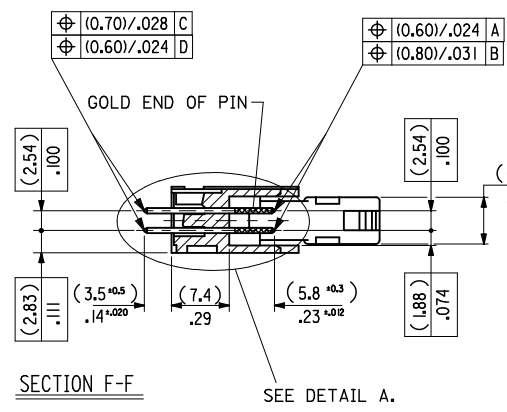

DIMENSIONS FOR SELECTIVE PLATING'S, SCALE 4:1

REMOVED REF'S TO COLOUR STAMP EC NO: E2011-0063 DRAWN: O'CONNOR CHKD: APPR: EFOLAN	QUALITY SYMBOLS ▽ = 0 ▽ = 0	GENERAL TOLERANCES (UNLESS SPECIFIED)		DIMENSION STYLE IN/MM	SCALE 2:1	DESIGN UNITS INCH	THIRD ANGLE PROJECTION
		4 PLACES ± --- ± ---	mm	INCH	DRAWN BY SM	DATE 3 / 8 / 90	TITLE QIK FLECS
		3 PLACES ± --- ± ---			CHECKED BY X	DATE	WIPE FEMALE
		2 PLACES ± 0.15 ± .005			APPROVED BY EFOLAN	DATE 2010/08/25	MOLEX INCORPORATED
		1 PLACE ± 0.02 ± .008	ANGULAR ± 1/2°		MATERIAL NO.	DOCUMENT NO. SDA-90571	SHEET NO. 1 OF 4
		DRAFT WHERE APPLICABLE MUST REMAIN WITHIN DIMENSIONS		THIS DRAWING CONTAINS INFORMATION THAT IS PROPRIETARY TO MOLEX INCORPORATED AND SHOULD NOT BE USED WITHOUT WRITTEN PERMISSION			

10 | 9 | 8 | 7 | 6 | 5 | 4 | 3 | 2 | 1

(78.74)/3.100	(86.34)/3.400	(90.52)/3.564	(96.62)/3.804	(100.74)/3.966	90571-1641	90571-1642	90571-1643		64
(73.66)/2.900	(81.26)/3.200	(85.44)/3.364	(91.54)/3.604	(95.66)/3.766	↑ -1601	↑ -1602	↑ -1603		60
(60.96)/2.400	(68.56)/2.700	(72.74)/2.864	(78.84)/3.104	(82.96)/3.266	-1501	-1502	-1503	90571-1509	50
(48.26)/1.900	(55.86)/2.200	(60.04)/2.364	(66.14)/2.604	(70.26)/2.766	-1401	-1402	-1403	↑ -1409	40
(40.64)/1.600	(48.24)/1.900	(52.42)/2.064	(58.52)/1.304	(62.64)/2.466	-1341	-1342	-1343	-1349	34
(35.56)/1.400	(43.16)/1.700	(47.34)/1.864	(53.44)/2.104	(57.56)/2.266	-1301	-1302	-1303	-1309	30
(30.48)/1.200	(38.08)/1.500	(42.26)/1.664	(48.36)/1.904	(52.48)/2.066	-1261	-1262	-1263	-1269	26
(22.86)/.900	(30.46)/1.200	(34.64)/1.364	(40.74)/1.604	(44.86)/1.766	-1201	-1202	-1203	-1209	20
(17.78)/.700	(25.38)/1.000	(29.56)/1.164	(35.66)/1.404	(39.78)/1.566	-1161	-1162	-1163	-1169	16
(15.24)/.600	(22.84)/.900	(27.02)/1.064	(33.12)/1.304	(37.24)/1.466	↓ -1141	↓ -1142	↓ -1143	↓ -1149	14
(10.16)/.400	(17.76)/.700	(21.94)/.864	(28.04)/1.104	(32.16)/1.266	90571-1101	90571-1102	90571-1103	90571-1109	10
A	B	C	D	E	ENG. NO. GSI PLATING	ENG. NO. GS2 PLATING	ENG. NO. GS3 PLATING	ENG. NO. PRE TIN	NO.OF CKTS.

NOTES

1. MATERIAL

HEADER : GLASS FILLED POLYESTER (UL 94V0), COLOUR - BLACK.
 PINS : BRASS SIZE \square (0.635)/.025 .
 LEVER : GLASS FILLED POLYESTER (UL 94V0), COLOUR - BLACK.

2. PLATING OPTIONS.

- 90571-1**1, (1um)/39uin MIN. NICKEL UNDERPLATE. CONTACT AREA GSI PLATING (0.1um)/4uin MIN. GOLD. SOLDER AREA (3um)/118uin MIN. TIN.
- 90571-1**2, (1um)/39uin MIN. NICKEL UNDERPLATE. CONTACT AREA GS2 PLATING (0.76um)/30uin MIN. GOLD. SOLDER AREA (3um)/118uin MIN. TIN.
- 90571-1**3, (1um)/39uin MIN. NICKEL UNDERPLATE. CONTACT AREA GS3 PLATING (0.25um)/10uin MIN. GOLD. SOLDER AREA (3um)/118uin MIN. TIN.
- 90571-1**9, (0.5-1um)/20-40uin NICKEL UNDER (1.0-3.0um)/39-118uin TIN. PRE-TIN

3. RECOMMENDED PCB THICKNESS 1.6mm

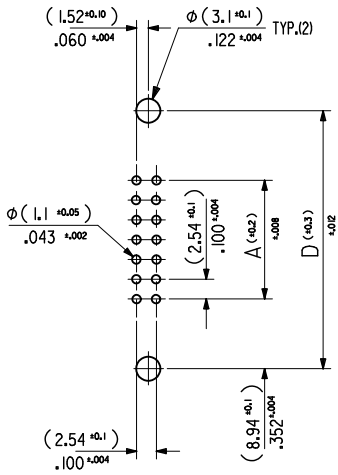

RECOMMENDED P.C.B.HOLE PATTERN.

REMOVED REF'S TO COLOUR STAMP EC NO: E2011-0063 DRAWN: O'CONNOR 2010/08/10 CHKD: 2010/08/25 APPR: EPOLAN 2010/08/30	QUALITY SYMBOLS ▽ = 0 ▽ = 0	GENERAL TOLERANCES (UNLESS SPECIFIED)		DIMENSION STYLE IN/MM		SCALE 2:1	DESIGN UNITS INCH	THIRD ANGLE PROJECTION	
		mm	INCH	DRAWN BY SM SM	DATE 3 / 8 / 00	TITLE QIK FLECS HEADER WITH DIN EJECT LEVERS FOR IMPROVED WIPE FEMALE			
		4 PLACES ± --- ± ---		CHECKED BY X	DATE	MOLEX INCORPORATED			
		3 PLACES ± --- ± ---		APPROVED BY EFOXAN	DATE 2010/08/25	DOCUMENT NO. SDA-90571			
		2 PLACES ± 0.15 ± .005		MATERIAL NO. SEE CHART		SHEET NO. 2 OF 4			
		1 PLACE ± 0.20 ± .008		DRAFT WHERE APPLICABLE MUST REMAIN WITHIN DIMENSIONS		THIS DRAWING CONTAINS INFORMATION THAT IS PROPRIETARY TO MOLEX INCORPORATED AND SHOULD NOT BE USED WITHOUT WRITTEN PERMISSION			

9 | 8 | 7 | 6 | 5 | 4 | 3 | 2 | 1