

3120

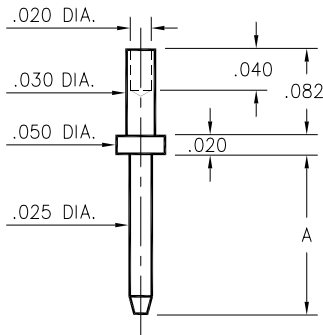

Basic Part Number	Length A
3120-1	.205
3120-2	.250

3120-X-00-XX-00-00-08-0
Swage mount in .034 mounting hole

3122 ⇒ 3153

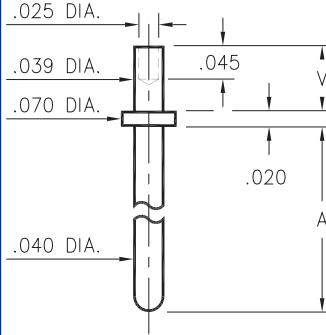

Basic Part Number	Pin Length A
3153-X	.180
3141-X	.230
3122-X	.280
3149-X	.380
3123-X	.580
3140-X	.780
3124-X	.880

- X -	Board Thickness	Length V
1	.031	.051
2	.062	.082

31XX-X-00-XX-00-00-08-0
Swage mount in .043 hole

3101 ⇒ 3106

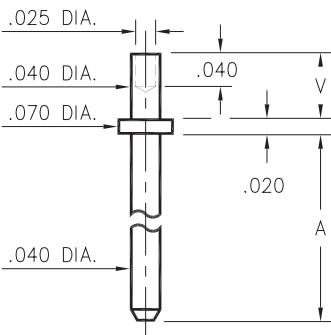

Basic Part Number	Pin Length A
3101-X	.150
3102-X	.188
3103-X	.300
3104-X	.500
3105-X	.750
3106-X	1.000

- X -	Board Thickness	Length V
1	.031	.051
2	.062	.082
3	.094	.113

310X-X-00-XX-00-00-08-0
Swage mount in .043 hole

3221 ⇒ 3223

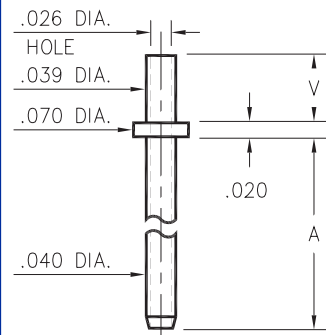

Basic Part Number	Pin Length A
3221-X	.100
3222-X	.150
3223-X	.300

- X -	Board Thickness	Length V
1	.031	.051
2	.062	.082
3	.094	.113

322X-X-00-XX-00-00-08-0
Swage mount in .043 hole

3125/3126

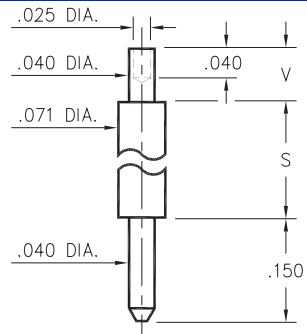

Basic Part Number	Pin Length S
3125-X	.170
3126-X	.420

- X -	Board Thickness	Length V
1	.031	.051
2	.062	.082
3	.094	.113

312X-X-00-XX-00-00-08-0
Swage mount in .043 hole

0995

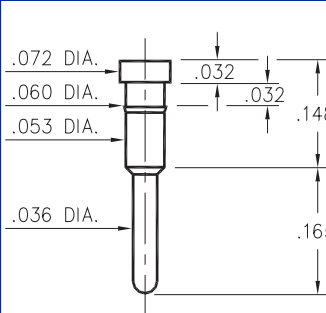

0995-0-00-XX-00-00-03-0
Press-fit in .057 mounting hole

4526

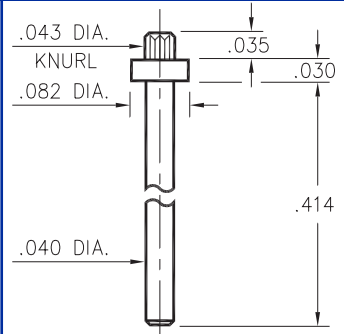

4526-0-00-XX-00-00-03-0
Press-fit in .040 mounting hole

SPECIFICATIONS

PIN MATERIAL:
Brass Alloy 360, 1/2 Hard
(Except Swage pins which are annealed)

DIMENSION IN INCHES
TOLERANCES ON:
LENGTHS: ±.005
DIAMETERS: ±.002
ANGLES: ± 2°

ORDER CODE: XXXX - X - 00 - XX - 00 - 00 - 0X - 0

BASIC PART #



SPECIFY PIN FINISH:
01 200µ" TIN/LEAD OVER NICKEL
80 200µ" TIN OVER NICKEL
15 10µ" GOLD OVER NICKEL
21 20µ" GOLD OVER NICKEL
34 50µ" GOLD OVER NICKEL