



Solving your relay requirements since 1922

C Series TDR



- ... Solid state analog circuitry
- ... Delay on operate timing mode
- ... Compact size
- ... Relay output with SPST or SPDT contacts
- ... Timing selection: Fixed or knob adjustable
- ... Numerous models timing from 0.1 secs. to 300 secs.
- ... UL File #E96739 (M)
- ... CSA File #LR62586-3

Timing Mode:

Delay on operate timing cycle begins upon application of input power. The relay contacts transfer at the end of the delay period and will remain transferred until input voltage is removed. Reset occurs when input voltage is removed.

Timing Diagram:

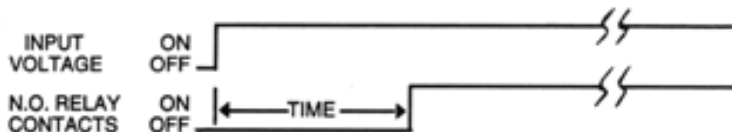

Contact Information:

Arrangement:

- 1 form A (SPST Normally open) - Diagram A
- 1 form B (SPST Normally closed) - Diagram A
- 1 form C (SPDT) - Diagram B

Contact Rating (Resistive)	Max. switching power	30W, 50VA
	Max. switching voltage	60V DC, 125V AC
	Max. switching current	1A DC, AC
	Max. carrying current	.05A AC; 1A 30V DC
UL/CSA Rating 0.5A AC; 1A 30V, DC		

Expected Life @ 25°C: 100,000 operations minimum at rated loads



Solving your relay requirements since 1922

Environmental Information

Temperature Range: Operating and storage: -25°C to $+60^{\circ}\text{C}$, (-13°F to $+140^{\circ}\text{F}$).

Mechanical Information:

Termination: .110 inch (standard), .250 inch or screw terminals (optional).

Enclosure: Black plastic case.

Mounting: Single screw or optional 2-screw panel mount Weight: 0.8 oz (23g) approx.

Outline Dimensions:

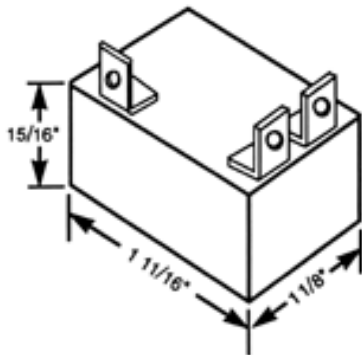

Timing Specifications:

Timing - Fixed: 0.1 through 300 secs.

Timing Ranges: 0.1 - 60, 60 - 120, 120 - 180, 180 - 240, 240 - 300 secs. Custom timing is available.

Timing Adjustment: Knob adjustable potentiometer.

Timing Tolerance: Fixed Units: $\pm 5\%$. Adjustable Units: -0 to $+25\%$ of maximum specified delay time.

Minimum specified value or less at low end.

Repeatability: $\pm 5\%$

Release Time: 60 ms typical, 100 ms maximum.

Timing Cycle Interrupt Transfer: None.

Initial Dielectric Strength:

Between open contacts: 500V RMS, between contacts & coil: 500V RMS.

Input Information:

Voltage: AC units- 12V, 24V, and 115V

DC units- 12V, 24V, 48V and 110V. Other voltages are available

Power Requirement: AC units: 3 VA or less. DC units: 3 Watts or less.

Polarity Protection: On DC units - Yes.

Input Voltages & Limits:



Solving your relay requirements since 1922

Nominal	Minimum	Maximum
12V AC	10V	14V
24V AC	20V	28V
115V AC	105V	130V
12V DC	11V	14V
24V DC	20V	32V
48V DC	41V	55V
110V DC	95V	125V

Wiring Diagrams:

**Single Pole - Single Throw
Normally Open or Normally Closed**

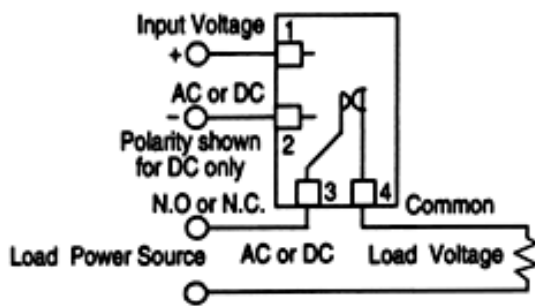

Diagram A

Single Pole - Double Throw

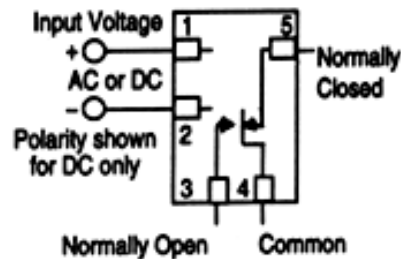

Diagram B



Ordering Information:

Definition of a part number for the Amperite C Series Time Delay Relay. Example:

115 A NO .1 -60 S C
 ↑ ↑ ↑ ↑ ↑ ↑ ↑
 A B C D E F G

A: Denotes nominal input voltage. Voltages Available: 12, 24, 115V AC; 12, 24, 48, 110V DC. Custom Voltages are available.



Solving your relay requirements since 1922

B: Denotes type of input current required for operation: A = AC - Alternating Current; D = DC - Direct Current.

C: Denotes contact form: NO= SPST - 1 form A, C = SPST - 1 form B. SPDT = 1 form C

D & E: Denotes range of knob adjustability for timing (in seconds) where:

D = Minimum time delay.

E = Maximum time delay for adjustable TDR'S.

Note:

1.) Ranges Available: 0.1 - 60, 60 - 120, 120 - 180, 180 - 240, 240 - 300 secs. Custom timing is available.

2.) Both values (D & E) can be replaced by a single value for a factory preset time delay in seconds from 0.1 through 300 secs.

F: Denotes form of termination - blank = .110 male electro-plate solder terminals (standard), X = .250 male quick connect terminals (optional), S = screw terminals.

G: Denotes use of solid-state analog circuitry of C Series.



Solving Your Relay Requirements Since 1922



AMPERITE CO.

(201) 864-9503 • (800) 752-2329 • Fax: (201) 864-3955
 E-Mail: info@amperite.com • Website: www.amperite.com

C Series TDR

- Solid state analog circuitry
- Delay on operate timing mode
- Compact size
- Relay output with SPST or SPDT contacts
- Timing selection: Fixed or knob adjustable
- Numerous models timing from 0.1 secs. to 300 secs.
- UL File #E96739 (M)
- CSA File # LR62586

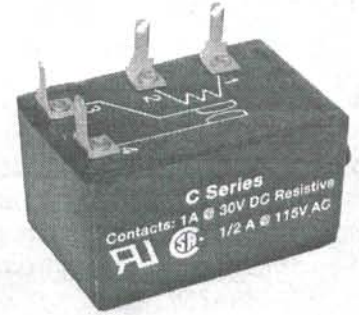

TIMING MODE: Delay on operate timing cycle begins upon application of input power. The relay contacts transfer at the end of the delay period and will remain transferred until input voltage is removed. Reset occurs when input voltage is removed.

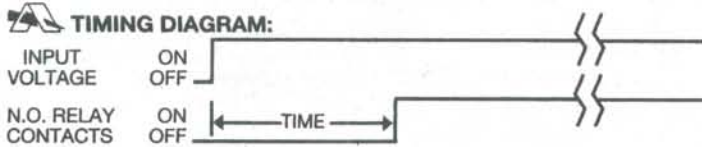

CONTACT INFORMATION:
 Arrangement: 1 form A (SPST Normally open) - Diagram A
 1 form B (SPST Normally closed) - Diagram A
 1 form C (SPDT) - Diagram B

Contact Rating (Resistive)	Max. switching power	30W, 50VA
	Max. switching voltage	60V DC, 125V AC
	Max. switching current	1A DC, AC
	Max. carrying current	0.5A AC, 1A 30V DC
UL/CSA rating	0.5A AC, 1A 30V DC	

Expected Life @ 25°C :
 100,000 operations minimum at rated loads

ENVIRONMENTAL INFORMATION:
 Temperature Range: Operating and storage: -25°C to +60°C,
 (-13°F to +140°F)

MECHANICAL INFORMATION:
 Termination: .110 inch, .250 inch or screw terminals
 Enclosure: Black plastic case
 Mounting: Single screw or optional 2-screw panel mount
 Weight: 0.8 oz (23g) approx.

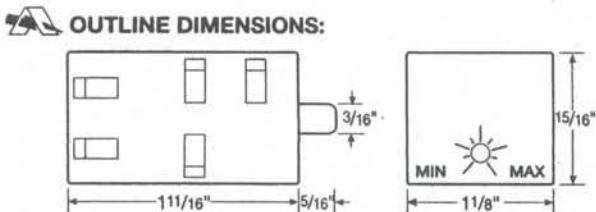

Ordering Information:
 Definition of a part number for the Amperite C Series Time Delay Relay.
 Example:

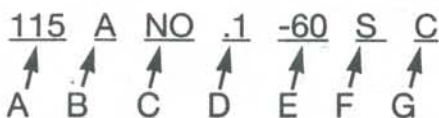

TIMING SPECIFICATIONS:
 Timing - Fixed: .1 through 300 secs.
 Timing Ranges: .1 - 60, 60 - 120, 120 - 180, 180 - 240, 240 - 300 secs.
Custom timing is available.

Timing Adjustment: Knob adjustable potentiometer.
 Timing Tolerance:
 Fixed Units: ± 5%
 Adjustable Units: -0 to +25% of maximum specified delay time.
 Minimum specified value or less at low end.

Repeatability: ± 5%
 Release Time: 60 ms typical, 100 ms maximum
 Timing Cycle Interrupt Transfer: none

INITIAL DIELECTRIC STRENGTH:
 Between open contacts: 500V RMS, Between contacts & coil: 500V RMS

INPUT INFORMATION:
 Voltage: AC units- 12V, 24V, and 115V
 DC units- 12V, 24V, 48V and 110V } **Other volt. are available**
 Power Requirement: AC units: 3 VA or less
 DC units: 3 Watts or less
 Polarity Protection: On DC units - Yes

INPUT VOLTAGES & LIMITS:

Nominal	Minimum	Maximum
12V AC	10V	14V
24V AC	20V	28V
115V AC	105V	130V
12V DC	11V	14V
24V DC	20V	32V
48V DC	41V	55V
110V DC	95V	125V

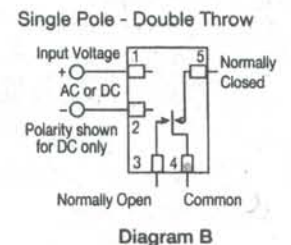
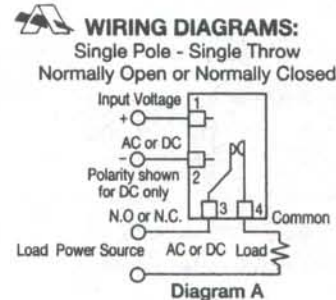

- A: Denotes nominal input voltage. Voltages Available: 12, 24 & 115V AC, 12, 24, 48 & 110V DC. **Custom Voltages are available.**
- B: Denotes type of input current required for operation: A = AC - Alternating Current
 D = DC - Direct Current
- C: Denotes contact form: NO = Normally Open - 1 form A, C = Normally Closed - 1 form B, SPDT = Single Pole, Double Throw - 1 form C.
- D & E: Denotes range of knob adjustability for timing (in seconds) where:
 D = Minimum time delay. E = Maximum time delay for adjustable TDR'S.
- Note: 1.) Ranges available: .1 - 60, 60 - 120, 120 - 180, 180 - 240 & 240 - 300 secs.
Custom timing is available.
 2.) Both values (D & E) can be replaced by a single value for a factory preset time delay in seconds from .1 through 300 secs.

From: Frank M. Kretkowski [mailto:fkretkowski@optonline.net]
Sent: Wednesday, November 19, 2008 7:20 AM
To: kevin.jackson@AlliedElec.com
Subject: Fw: C-Series Technical Data Sheet with contact rating revision

Hello Kevin,

Please find attached a file for the C-Series Technical Data Sheet.
We are in agreement that the contact rating (maximum switching current) is incorrectly specified as 0.05A AC where the correct specification should be 0.5A AC.
It may be a period of time before this information is corrected on the website.
I apologize for the inconvenience and if you need any additional assistance, please feel free to contact us.

Frank M. Kretkowski
Technical Support
Amperite Co.
1-800-752-2329 ext.12

----- Original Message -----

From: AmperiteCo@aol.com
To: fkretkowski@optonline.net
Sent: Wednesday, November 19, 2008
Subject: C-Series Technical Data Sheet