

Features

Regulated Converters

- Ultracompact Low Profile AC-DC Power Supply
- Ultra-low 30mW Standby Power Consumption
- 1 Watt or 2 Watt PCB Mount Package
- Extra Wide Input Voltage Range (90~277VAC)
- Class II Power Supply with 3kVAC Isolation
- -25°C to +85°C Operating Temp
- Low Output Ripple
- Short Circuit Protected Outputs
- UL, EN and CE Certified

Selection Guide

| Part Number | Input Range (VAC) | Output Voltage (VDC) | Output Current (mA) | Efficiency (%) | Max Capacitive Load |
|--------------|-------------------|----------------------|---------------------|----------------|---------------------|
| RAC01-3.3SC* | 90-277 | 3.3 | 300 | 63 | 2200µF |
| RAC02-3.3SC* | | | 600 | 63 | |
| RAC01-05SC* | 90-277 | 5 | 200 | 68 | 2200µF |
| RAC02-05SC* | | | 400 | 70 | |
| RAC01-09SC* | 90-277 | 9 | 111 | 72 | 1200µF |
| RAC02-09SC* | | | 222 | 74 | |
| RAC01-12SC* | 90-277 | 12 | 83 | 72 | 1000µF |
| RAC02-12SC* | | | 167 | 74 | |
| RAC01-15SC* | 90-277 | 15 | 67 | 72 | 680µF |
| RAC02-15SC* | | | 133 | 74 | |
| RAC01-24SC* | 90-277 | 24 | 42 | 72 | 330µF |
| RAC02-24SC* | | | 83 | 75 | |

Specifications (typical at 25°C, Full Load and after warm up time unless otherwise specified)

| | | |
|---|--|------------------------|
| Input Voltage Range | 90-277VAC or 120-390VDC | |
| Rated Power | 1 or 2 Watts max. | |
| Input Frequency Range (for AC Input) | 40-63Hz | |
| Input Current (full load) | 115/230VAC | 41mA/27mA typ. |
| No Load Power Consumption | 115VAC | 30mW typ. |
| Inrush Current (<0.5ms) | 115/230VAC | 10/20A max. |
| Leakage Current | 1.5mA max. | |
| Output Voltage Tolerance (combined Tolerance, Line Reg and Load Reg at full load) | ±5% max. | |
| Line Voltage Regulation | low line, high line at full load | ±2% max. |
| Load Voltage Regulation | 10% to 100% full load | ±6% max. |
| Output Ripple (20MHz BW limited, with 0.1µF on output) | <0.4V typ. | |
| Operating Frequency | 40kHz typ. | |
| Leakage Current | 1.5mA max. | |
| Minimum Load = 0% | specifications valid for 10% minimum load only | |
| RMS Isolation Voltage (input to output) | 3kVAC / 1 minute | |
| Isolation Resistance | 1 GΩ min. | |
| Isolation Capacitance | 1000pF typ. | |
| Short Circuit Protection | Hiccup, Automatic Restart | |
| Output Overvoltage Protection | 105%~115% of Vout max. | |
| Overload Protection | 115/230VAC | 115%~140% of Iout max. |
| Operating Temperature Range | (1W, natural convection, no derating) | -25°C to +80°C |
| | (2W natural convection, no derating) | -25°C to +75°C |
| | (natural convection, with derating) | -25°C to +85°C |
| Storage Temperature Range | -40°C to +85°C | |
| Humidity | non-condensing | 95% RH max |
| Case Material | Plastic Case, Epoxy filled (UL94V-0) | |
| Package Weight | 25g | |
| Packing Quantity | 12 pcs | |

RAC01-02

POWERLINE

AC/DC-Converter

with 3 year Warranty

RECOM

1 - 2 Watt Single Output



EN-60950-1 Certified
UL-60950-1 pending

RAC01-C RAC02-C

Description

The RAC01-SC and RAC02-C series are ultra-compact universal input AC/DC power modules for PCB mounting. They feature high efficiency, low standby power, high operating temperature, low output ripple/noise, short-circuit, overload and output over-voltage protection as well as a built-in EMC Class B filter.

Derating Graph

(Ambient Temperature)

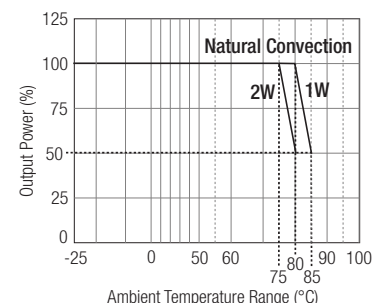

Please Read Application Notes

www.recom-electronic.com

POWERLINE

AC/DC-Converter

RAC01-SC

RAC02-SC

Specifications (typical at 25°C and after warm up time unless otherwise specified)

| | | |
|-------------------|--|-------------------------------|
| EMC | Conducted and Radiated Noise Immunity | EN 55022 Class B EN 55024 |
| MTBF (+25°C) | using MIL-HDBK-217F | >1000 x 10 ³ hours |
| Certifications: | | |
| UL General Safety | (Pending) | UL-60950-1, 2nd Edition |
| EN General Safety | | EN-60950-1, 2nd Edition |

Standard Package Style and Pinning

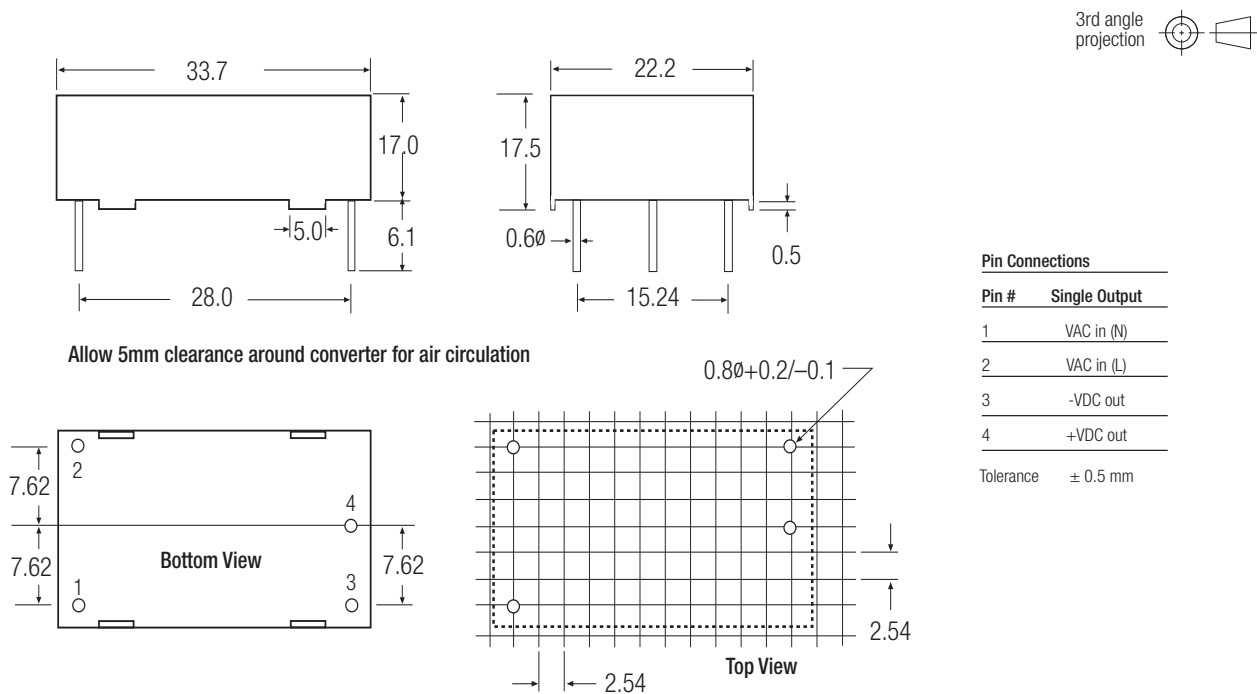

RAC01-02

Standard Application Circuit

Compact single output regulated power supply

Suggested fuse rating: 1A Slow Blow.

An external MOV is required for 230VAC operation. The varistor should comply with IEC-61051-2.

