

ISS.	DATE	E.C.N.	DESCRIPTION
1	25-Feb-09		FIRST ISSUE

© 2006 CARCLO  
ALL DIMENSIONS IN mm

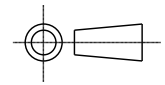

CUSTOMER DRAWING

SECTION A-A  
SCALE 2:1

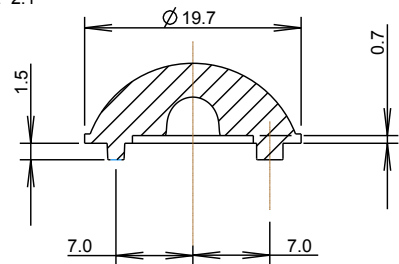

DIAMOND DOWEL  
DETAIL C  
SCALE 10:1

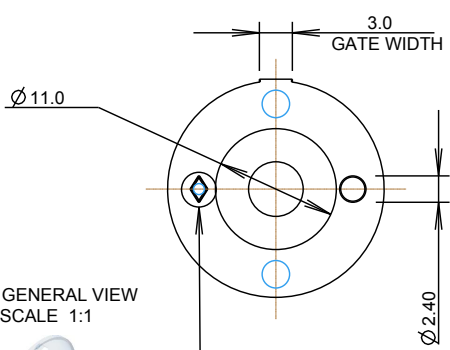
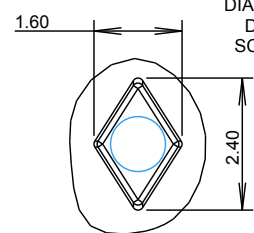

3D GENERAL VIEW  
SCALE 1:1



DIAMOND DOWEL  
SEE DETAIL C

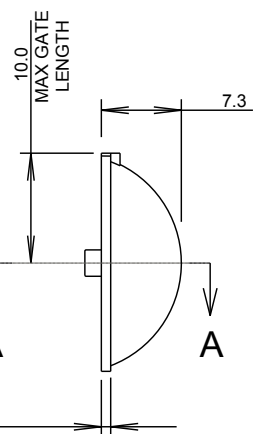

MATERIAL: POLYCARBONATE



CARCLO TECHNICAL PLASTICS (SLOUGH)  
111 BUCKINGHAM AVE, SLOUGH  
SL1 4PF, ENGLAND  
TEL: +44 1753 575011 FAX: +44 1753 811359  
e-mail: design@carclo-optics.com

GENERAL TOLERANCES (UNLESS STATED)

LINEAR	ANGULAR
X +/- 0.25	X +/- 1°
X.X +/- 0.1	X.X +/- 0.5°
X.XX +/- 0.05	X.XX +/- 0.1°

CUSTOMER

CARCLO

TITLE

UNIFORM HEMI-SPHERICAL  
EMITTER BUBBLE OPTIC

DRAWN DATE  
AJD 25-Feb-09

CHK'D DATE

APP'D DATE

SCALE CARCLO PART No.  
2:1 10620

SIZE CARCLO DRG. No. SHEET  
A4 60570 1 OF 2

ISS.	DATE	E.C.N.	DESCRIPTION
1	25-Feb-09		FIRST ISSUE

© 2006 CARCLO  
ALL DIMENSIONS IN mm

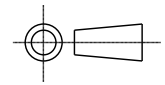

PCB GLUE PAD AND ALIGNMENT HOLE  
LAYOUT DIMENSIONS

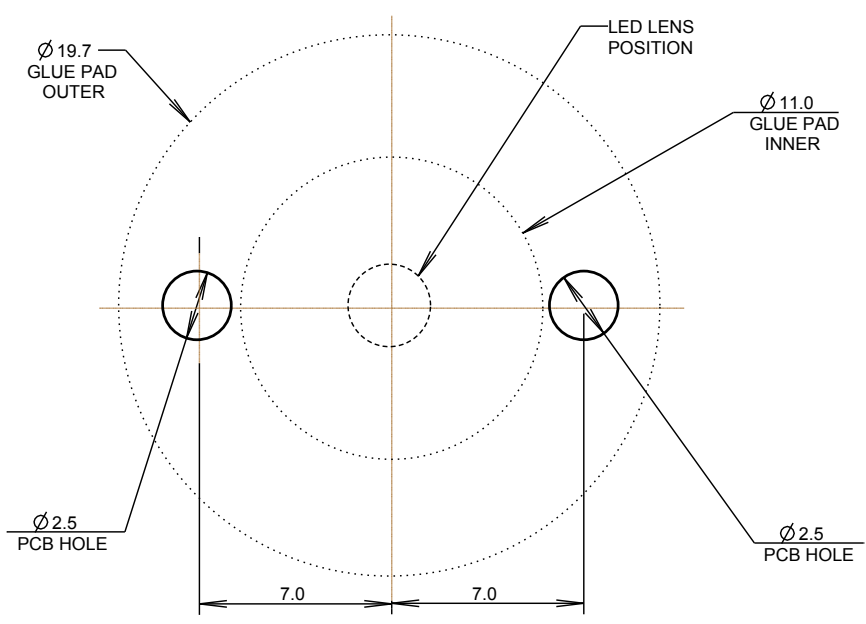

NOTE: THE CLOSEST THAT TWO OR MORE LENSES CAN BE PLACED TOGETHER WITHOUT OBSCURATION IS 27MM BETWEEN CENTRES.

**CARCLO TECHNICAL PLASTICS (SLOUGH)**  
111 BUCKINGHAM AVE, SLOUGH  
SL1 4PF, ENGLAND  
TEL: +44 1753 575011 FAX: +44 1753 811359  
e-mail: design@carclo-optics.com

GENERAL TOLERANCES (UNLESS STATED)

LINEAR	ANGULAR
X +/- 0.25	X +/- 1°
X.X +/- 0.1	X.X +/- 0.5°
X.XX +/- 0.05	X.XX +/- 0.1°

CUSTOMER		
CARCLO		
TITLE		
UNIFORM HEMI-SPHERICAL EMITTER BUBBLE OPTIC		
DRAWN	DATE	
AJD	25-Feb-09	
CHK'D	DATE	
APP'D	DATE	
SCALE	CARCLO PART No.	
5:1	10620	
SIZE	CARCLO DRG. No.	SHEET
A4	60570	2 OF 2